

INTRODUCTION (1)

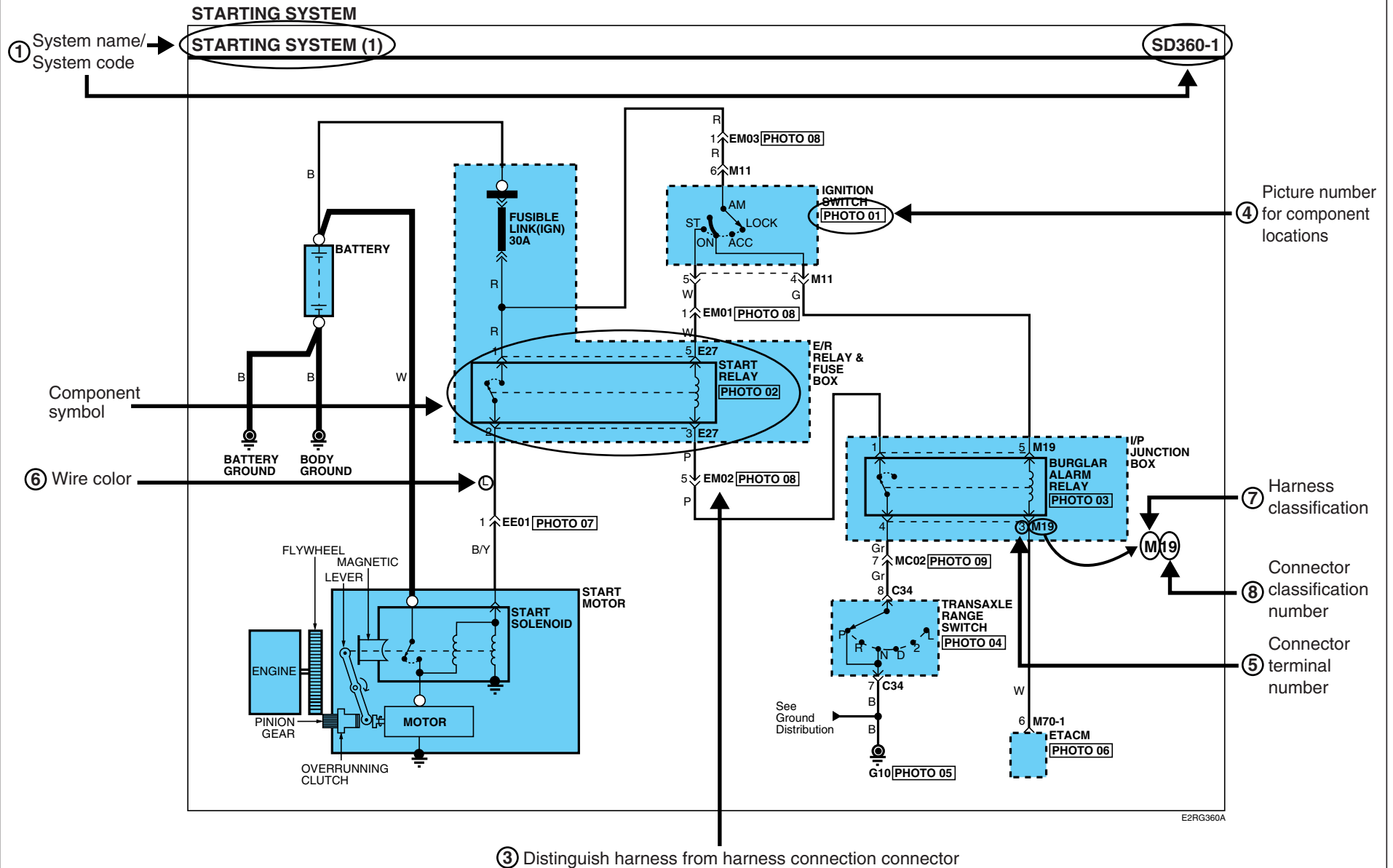

E2RG360A

INTRODUCTION

INTRODUCTION (2)

GI-2

STARTING SYSTEM

STARTING SYSTEM (2)

SD360-2

② Connector configurations (components)

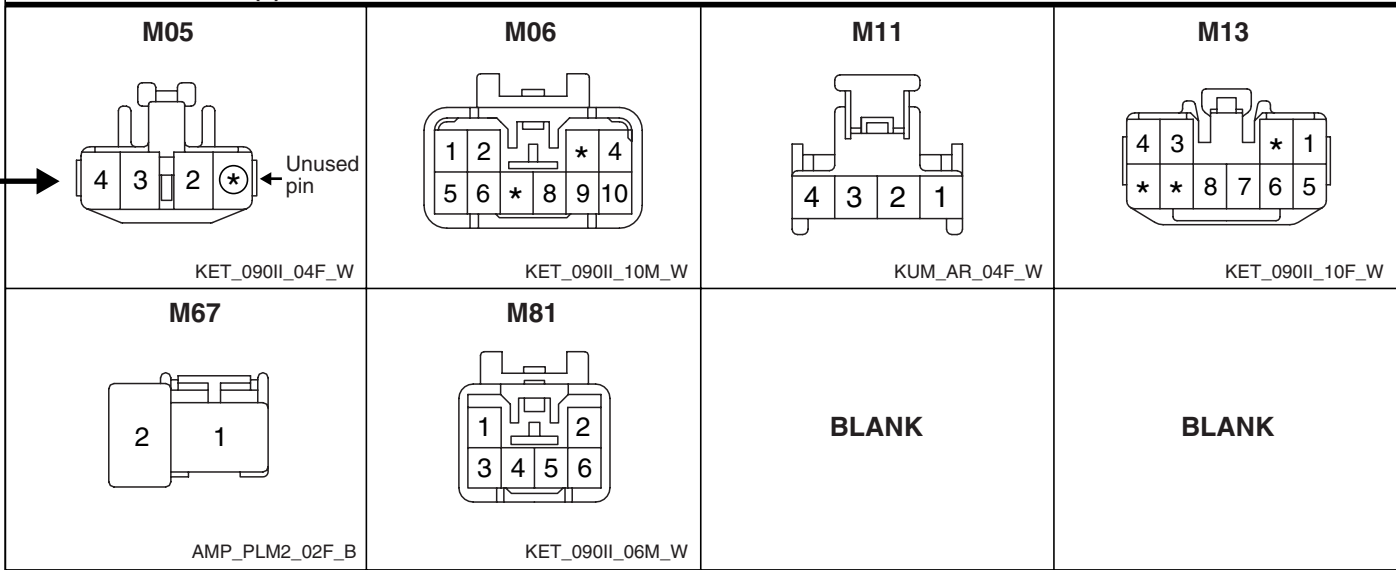

E2RG360B

Explanation of connector code

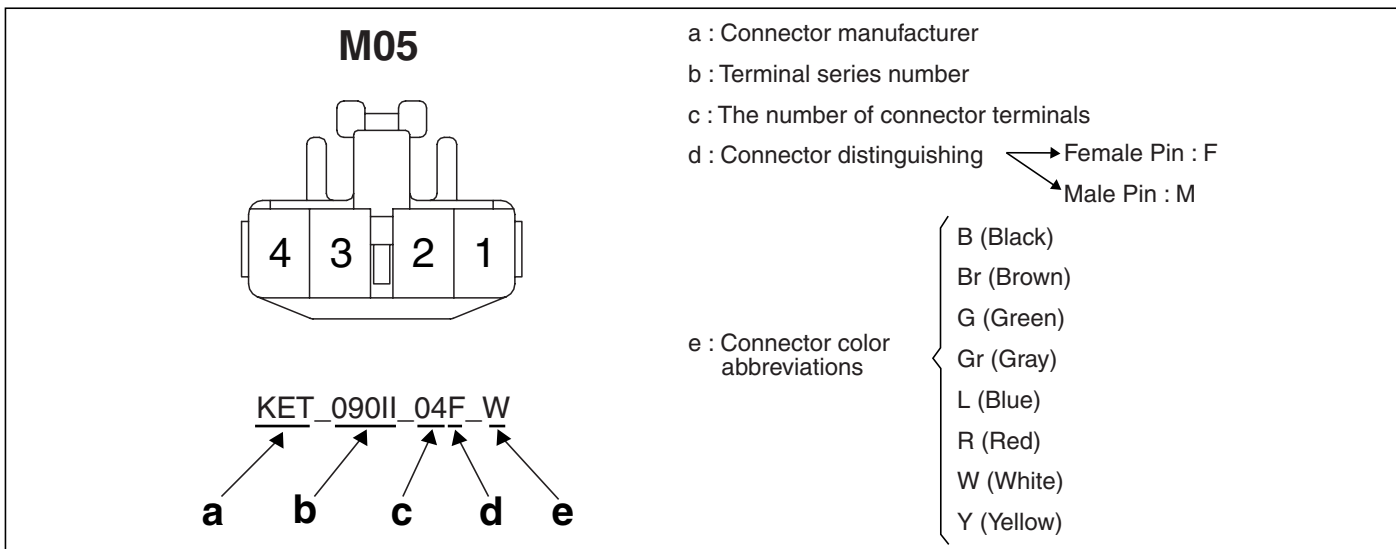

**INTRODUCTION**

**INTRODUCTION (3)**

**GI-3**

**① Pages by system/ Name of Schematic diagram**

- Each page is consisted of circuits by system. This schematic diagram includes the path of electricity flow, connection condition for each switch, and the function of other relevant circuits at once. It is applicable to real service work.
- It is very important to understand relevant circuits exactly before troubleshooting diagnosis.
- Circuits by system depends upon part number and are indicated on schematic diagram index.

**② Connector configuration (components)**

- The connector figure of components in the schematic diagram by system is indicated on the last page of schematic diagram.
- It shows the front of the connector on the harness side when not to the harness connector. The terminal number on each connector can be obtained by following the pattern used in ⑤ connector view and numbering order. Unused terminals are marked with an asterisk (\*).

**③ Connector configurations (connection between harnesses)**

- When connecting the harness with connector between harnesses, it shows female and male connectors and indicates them on the connector configurations group.

**EM02**

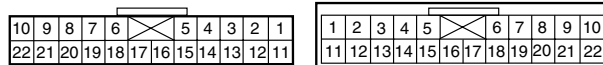

**④ Component locations**

- To find the components easily, a component locations diagram is indicated with "PHOTO NO" on the lower portion of the component name.
- To make it easy to distinguish connectors, the connector in the picture is indicated being installed in the vehicle.

**PHOTO 03**

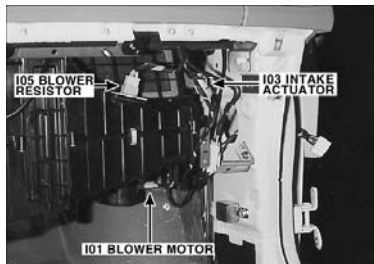

**⑤ CONNECTOR VIEW AND NUMBERING ORDER**

Female	Male	Remarks
		It is not the shape of the connector housing, but the connector pin that distinguishes between male or female connectors. When numbering female and male connectors, refer to the numbering order in the following table. Some connectors may not follow this method of numbering order. For individual detailed numbering, refer to the CONNECTOR CONFIGURATIONS.
		Numbered in order from upper right to lower left  Numbered in order from upper left to lower right

**NOTE**

**UNLESS OTHERWISE STATED, ALL CONNECTOR VIEWS ARE FROM THE TERMINAL SIDE OF THE CONNECTOR.**

**INTRODUCTION**

**INTRODUCTION (4)**

**GI-4**

**⑥ WIRE COLOR ABBREVIATIONS**

The following abbreviations are used to identify wire colors in the circuit schematics.

Symbol	Color of wire	Symbol	Color of wire
B	Black	O	Orange
Br	Brown	P	Pink
G	Green	R	Red
Gr	Gray	W	White
L	Blue	Y	Yellow
Lg	Light Green	Pp	Purple
T	Tan	LI	Light Blue

\* **(Y/B)**: Black stripe with yellow ground (2 colors)

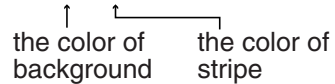

**⑦ HARNESS CLASSIFICATION**

Electrical wiring connectors are classified according to the wiring parts in the Harness Layouts.

Symbol	Harness name	Location
E	Engine, Battery harness	Engine, Battery
M	Main, Console EXT. harness	Passenger compartment
F	Floor harness	Floor
C	Control, PTC heater, Ignition EXT., MTM EXT. harness	Engine compartment, Passenger compartment
R	Trunk lid, Tail gate, Tail gate EXT., Roof, Rear fog lamp EXT. harness	Roof, Trunk, Tail gate
A	Air bag, Air con harness	Under crash pad and Floor
D	Door harness	Door

\* It depends on vehicles, it is necessary to check the harness name symbol on the harness layouts for detailed symbol.

**⑧ CONNECTOR IDENTIFICATION**

A connector identification symbol consists of a wiring harness location classification symbol corresponding to a wiring harness location and number corresponding to the connector. These connector locations can be found in the HARNESS LAYOUTS.

For example:

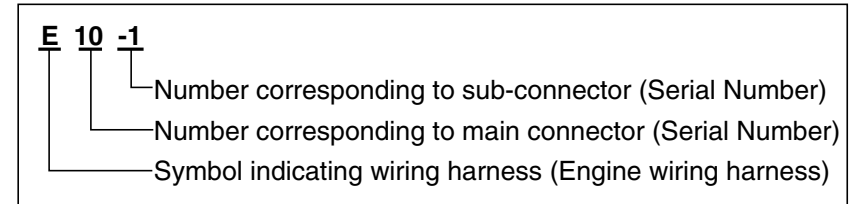

**NOTE**

**Connectors which connect each wiring harness are represented by the following symbols.**

For example:

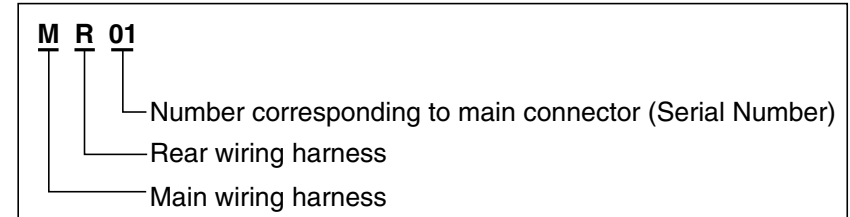

**JUNCTION BLOCK IDENTIFICATION**

A junction block identification symbol consists of a wiring harness location classification symbol corresponding to a wiring harness location and number corresponding to the connector in the junction block.

For example:

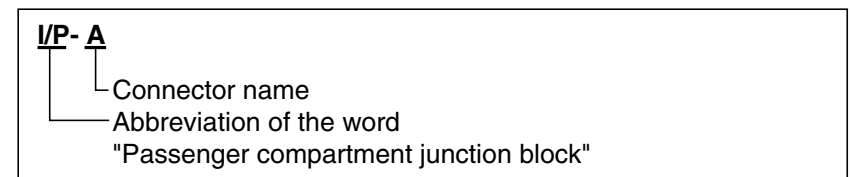



# INTRODUCTION

## INTRODUCTION (5)

GI-5

### HARNESS LAYOUTS

Harness layouts show the routing of the major wiring harnesses, the in-line connectors and the splices between the major harnesses. These layouts will make electrical troubleshooting easier.

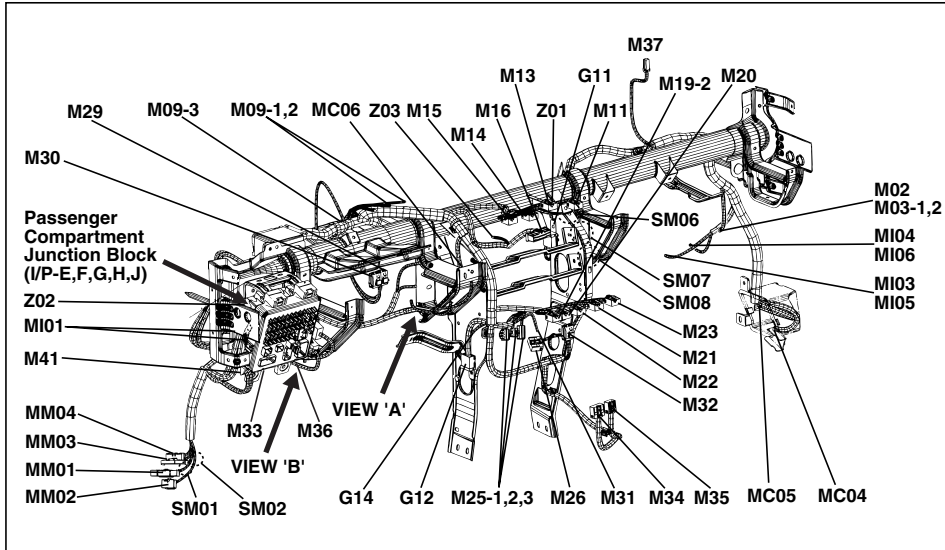









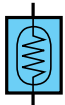
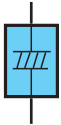

SYMBOLS (1)

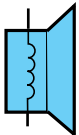
Section	Symbol	Meaning	Section	Symbol	Meaning	Section	Symbol	Meaning	
C O M P O N E N T		A solid line means the entire component is shown.	C O N N E C T O R		Shows the name of each connector on the component location index for reference.	S H I E L D W I R E		This represents RFI (Radio Frequency Interference) Shielding around a wire. The shielding is always connected to ground.	
		A broken line indicates only part of the component is shown.			Indicates the number of corresponding terminal. (Only relevant terminal on the corresponding schematic diagram).				Double filament
		This means the connector connects directly to the component.		The dashed-line means each of two wires connect with same connector(E35)	J O I N T C O N N E C T O R		D I O D E		Diode
		This indicates the connector connects to a lead (pigtail), wired directly to the component.		A wavy line means the wire is broken but is to be continued.					Led diode
		This indicates a screw terminal on the component.		Wire insulation is yellow with a red strip.	S O W B L O W		T R		Zener diode
		This ground symbol (dot and 3 lines overlapping the component) means the housing of the component is attached to a metal part of the vehicle.		Current path is continued on the same page or another page. The arrow shows the direction of current flow. You should look for the "A" in the marked position.					NPN
		This indicates a screw terminal on the component.		A wire connects to another circuit. The wire is shown again on that circuit which the arrow is pointing.	F U S E		G E N E R A L C O M P O N E N T S Y M B O L		PNP
		The name of the component appears next to its upper right corner.		Wire choices for options or different models are labeled and shown with a "choice" bracket like this.					This means power is supplied with the ignition on position.
	Shows the number of pictures for component location.		Splices are numbered and shown as a dot with circle. The exact location and connection of these splices may vary among vehicles.	C O N T R O L L O C A T I O N			Switch (1 contact point)		
			This symbol means the end of the wire is attached to a metal part of the vehicle.					Heater	

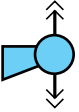
SYMBOLS

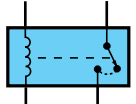
SYMBOLS (2)

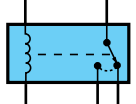
GI-7

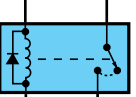
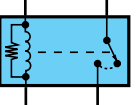
Section	Symbol	Meaning	Section	Symbol	Meaning
GENERAL COMPONENTS SYMBOL		Sensor	GENERAL COMPONENTS SYMBOL		Condenser
		Sender			Speaker
		Injector			Horn, Buzzer, Siren, Chime Bell
		Solenoid	RELAY		Normally open contact
		Motor			This is a relay shown with no current flowing through its coil. When a current flows through coil, contact will toggle.
		Battery			Diode interior relay
				Resistance interior relay	

## TROUBLESHOOTING INSTRUCTIONS (1)

GI-8

## TROUBLESHOOTING INSTRUCTIONS

## TROUBLESHOOTING PROCEDURES

The following five-step troubleshooting procedure is recommended.

**1. Verify the customer's complaints**

Turn on all the components in the problem circuit to check the accuracy of the customer's complaints. Note the symptoms.

Do not begin disassembly or testing until you have narrowed down the probable causes.

**2. Read and analyze the schematic diagram**

Locate the schematic for the problem circuit. Determine how the circuit is supposed to work by tracing the current paths from the power source through the system components to ground. If you do not understand how the circuit should work, read the circuit operation text. Also check other circuits that share with the problem circuit. The name of circuits that share the same fuse, ground, or switch, for example, are referred to on each diagram. Try to operate any shared circuits you did not check in step 1. If the shared circuit works, the shared wiring is okay, and the cause must be within the wiring used only by the problem circuit.

If several circuits fail at the same time, the fuse or ground is a likely cause.

**3. Inspect the circuit/ component with the problem isolated**

Make a circuit test to check the diagnosis you made in step 2. Remember that a logical, simple procedure is the key to efficient troubleshooting. Narrow down the probable causes using the troubleshooting hints and system diagnosis charts.

Test for the most likely cause of failure first.

Try to make tests at points that are easily accessible.

**4. Repair the problem**

Once the problem is found, make the necessary repairs.

**5. Make sure the circuit works**

Repeat the system check to be sure you have repaired the problem. If the problem was a blown fuse, be sure to test all of the circuits on that fuse.

## TROUBLESHOOTING EQUIPMENT

**VOLTMETER AND TEST LAMP**

Use a test lamp or a voltmeter on circuits without solidstate units and use a test lamp to check for voltage. A test lamp is made up of a 12-volt light bulb with a pair of leads attached. After grounding one lead, touch the other lead to various points along the circuit where voltage should be present.

When the bulb goes on, there is voltage at the point being tested.

**CAUTION**

**A number of circuits include solid-state modules, such as the Engine Control Module(ECM), used with computer command control injection. Voltage in these circuits should be tested only with a 10-megaohm or higher impedance digital multimeter. Never use a test lamp on circuits that contain solid state modules. Damage to the modules may result.**

A voltmeter can be used in place of a test lamp. While a test lamp shows whether the voltage is present or not, a voltmeter indicates how much voltage is present.

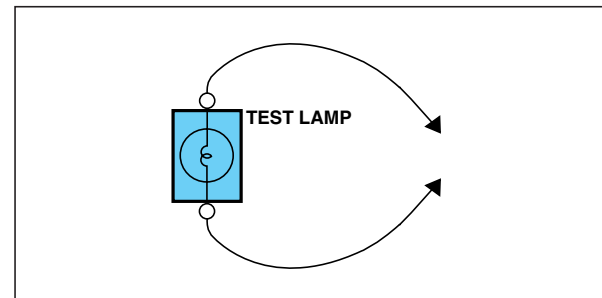
**SELF-POWERED TEST LAMP AND OHMMETER**

Use a self-powered test lamp or an ohmmeter to check for continuity.

The ohmmeter shows how much resistance there is between two points along a circuit. Low resistance means good continuity.

## TROUBLESHOOTING INSTRUCTIONS

## TROUBLESHOOTING INSTRUCTIONS (2)

GI-9

**CAUTION**

**Never use a self-powered test lamp on circuits that contain solid state modules. Damage to these modules may result.**

An ohmmeter can be used in place of a self-powered test lamp. The ohmmeter shows how much resistance there is between two points along a circuit. Low resistance means good continuity.

Circuits which include any solid-state devices should be tested only with a 10-megaohm or higher impedance digital multimeter. When measuring resistance with a digital multimeter, the battery negative terminal should be disconnected. Otherwise, there may be incorrect readings. Diodes and solid-state devices in a circuit can make an ohmmeter give a false reading. To find out if a component is affecting a measurement, take one reading, reverse the leads and take a second reading. If different the solid-state device is affecting the measurement.

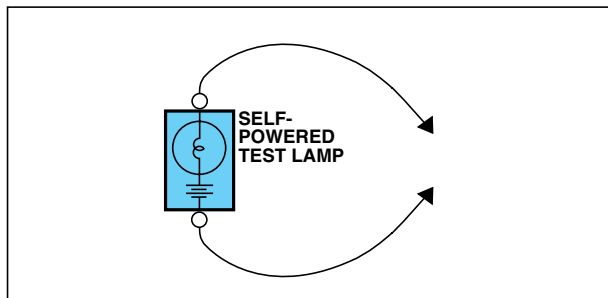
**JUMPER WIRE WITH FUSE**

Use a jumper wire with a fuse to by-pass an open circuit.

A jumper wire is made up of an in-line fuse holder connected to a set of test leads. This tool is available with small clamp connectors providing adaption to most connectors without damage.

**CAUTION**

**Do not use a fuse with a higher rating than the specified fuse that protects the circuit being tested. Do not use this tool in any situation to substitute an input or output at the solid-state control module, such as ECM, TCM, etc.**

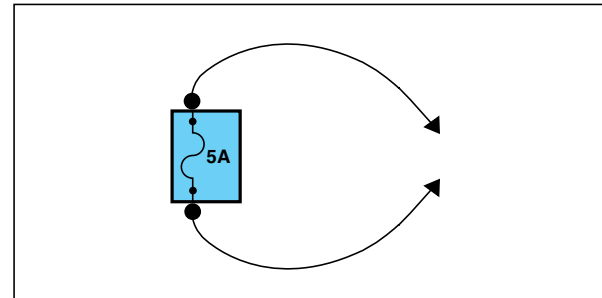
**SHORT FINDER**

A short finder is available to locate a short to ground. The short finder creates a pulsing magnetic field in the shorted circuit and shows you the location of the short through body trim or sheet metal.

**TROUBLESHOOTING TEST****1. TESTING FOR VOLTAGE**

This test measures voltage in a circuit. When testing for voltage at a connector, you do not have to separate the two halves of the connector. Instead, probe the connector from the back(backprobe). Always check both sides of the connector because dirt and corrosion between its contact surfaces can cause electrical problems.

- A. Connect one lead of a test lamp or voltmeter to a ground. If you are using a voltmeter, be sure it is the voltmeter's negative test lead you have connected to ground.
- B. Connect the other lead of the test lamp or voltmeter to a selected test point(connector or terminal).
- C. If the test lamp glows, there is voltage present. If you are using a voltmeter, note the voltage reading. A loss of more than 1 volt from specification indicates a problem.

**TROUBLESHOOTING INSTRUCTIONS**

**TROUBLESHOOTING INSTRUCTIONS (3)**

**GI-10**

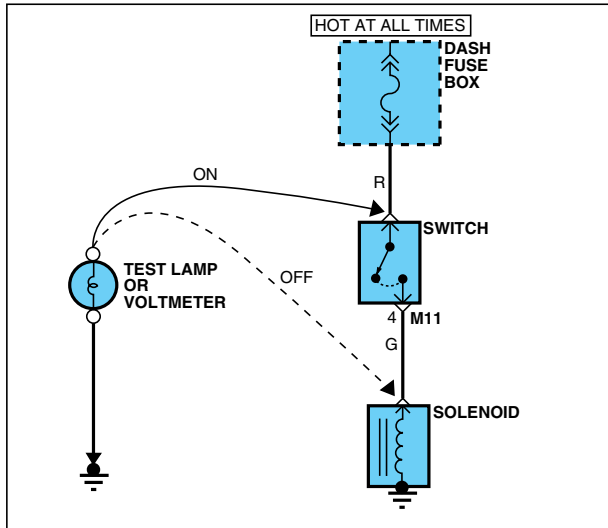

**2. TESTING FOR CONTINUITY**

- Disconnect the battery negative terminal.
- Connect one lead of a self-powered test lamp or ohmmeter to one end of the part of the circuit you wish to test. If you are using an ohmmeter, hold the leads together and adjust the ohmmeter to read zero ohms.
- Connect the other lead to the other end.
- If the self-power test lamp glows, there is continuity. If you are using an ohmmeter, low or zero resistance means good continuity.

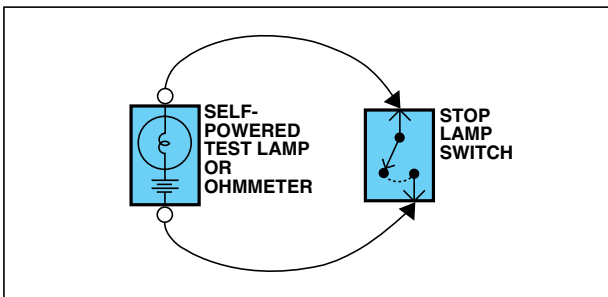

**3. TESTING FOR SHORT TO GROUND**

- Disconnect the battery negative terminal.
- Connect one lead of a self-powered test lamp or an ohmmeter to the fuse terminal on the load side.
- Connect the other lead to a ground.
- Beginning near the fuse block move the harness from side to side. Continue this procedure (about six inches apart) while watching the self-powered test lamp or ohmmeter.
- When the self-powered test lamp glows, or ohmmeter registers, there is a short to a ground in the wiring near that point.

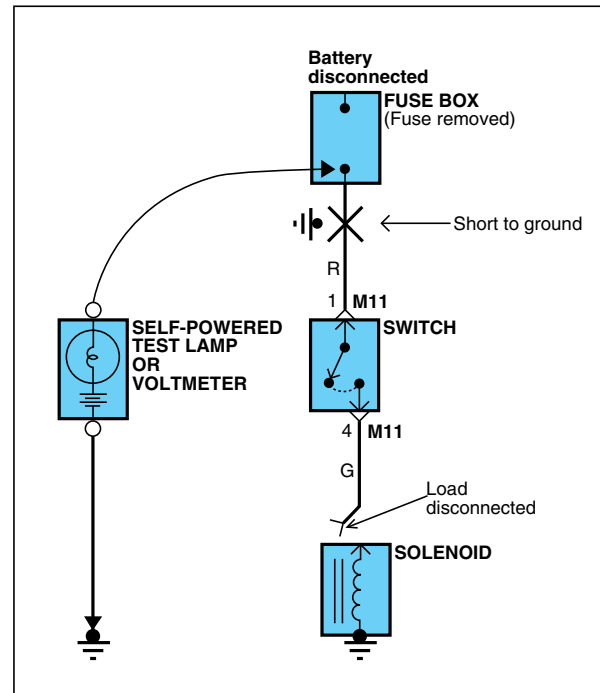

## TROUBLESHOOTING INSTRUCTIONS

## TROUBLESHOOTING INSTRUCTIONS (4)

GI-11

## 4. TESTING FOR A SHORT WITH A SHORT FINDER

- A. Remove the blown fuse. Leave the battery connected.
- B. Connect the short finder across the fuse terminals.
- C. Close all switches in series in the circuit that is being testing.
- D. Turn on the short circuit locator. It sends pulses of current to the short.  
This creates a pulsing magnetic field around the wiring between the fuse box and the short.
- E. Beginning at the fuse box, slowly move the short finder along the circuit wiring. The meter will show current pulses through sheet metal and body trim. As long as the meter is between the fuse and the short, the needle will move with each current pulse. Once the meter is moved past the point of the short, the needle will stop moving. Check around this area to locate the cause of the short circuit.

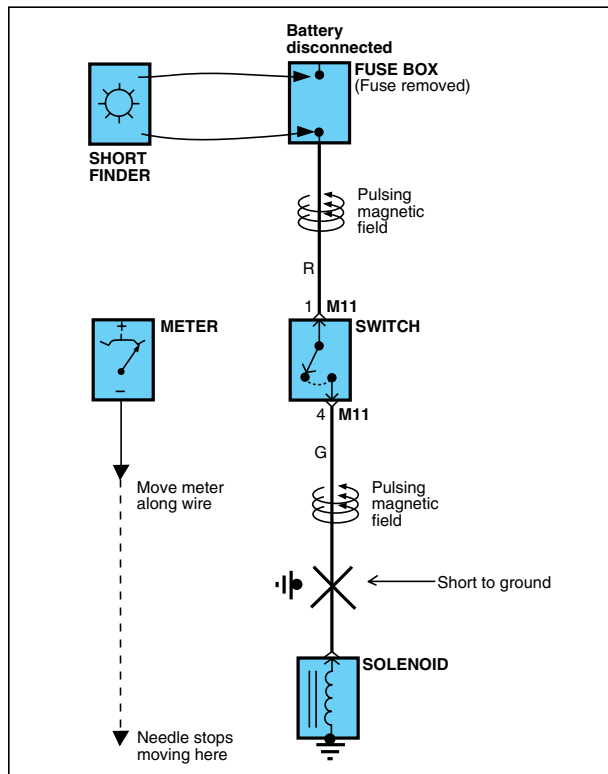

FUSE & RELAY INFORMATION EECB4FE1

FUSE & RELAY INFORMATION (1)

SD100-1

< FRONT >

I/P JUNCTION BOX

< REAR >

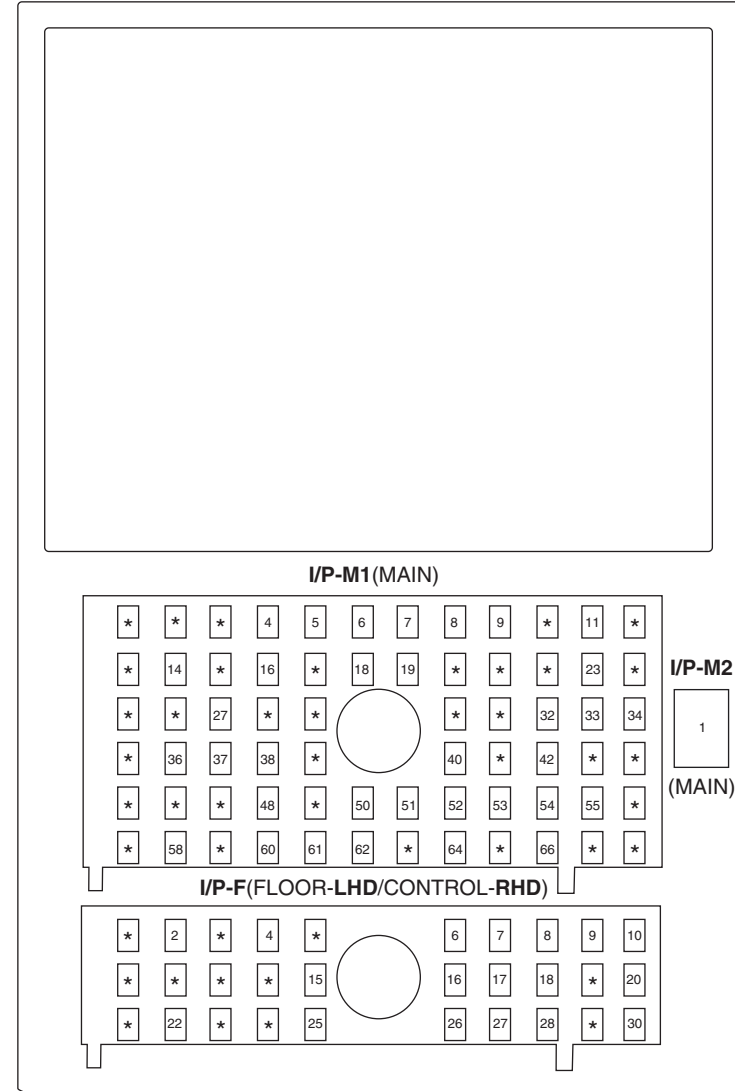
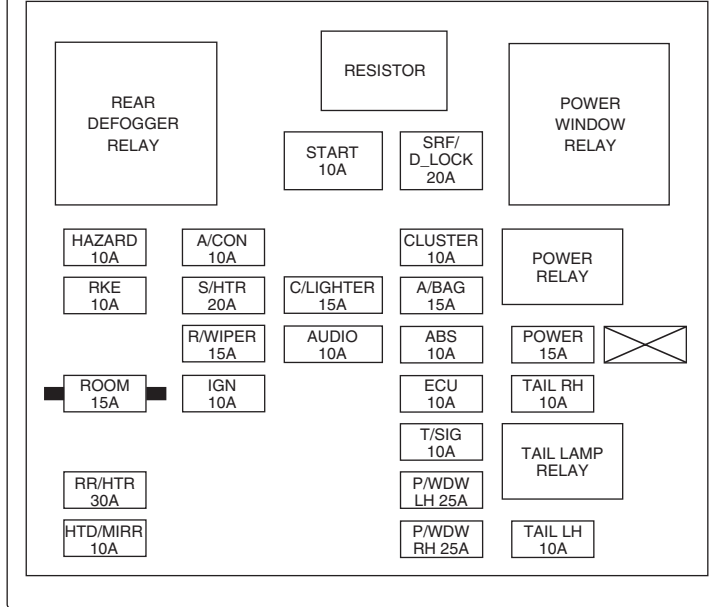
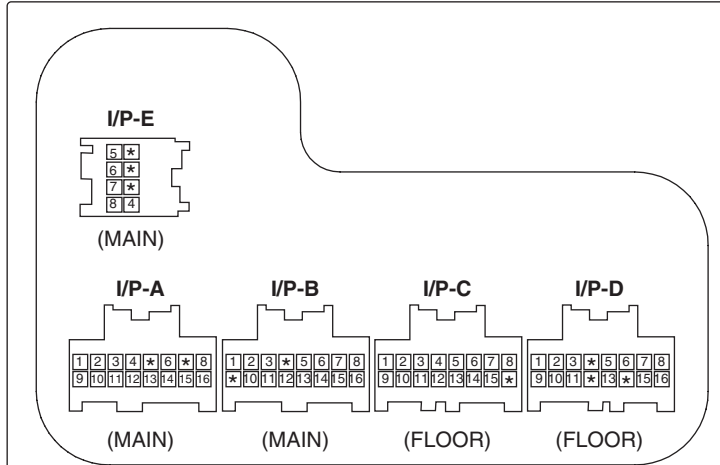

✘ USE THE DESIGNATED FUSE ONLY



**FUSE & RELAY INFORMATION**

**FUSE & RELAY INFORMATION (2)**

**SD100-2**

**CIRCUIT**

FUSE	(A)	Circuit Protected
HAZARD	10A	Instrument Cluster, Rear Combination Lamp, Side Repeater Lamp, Front Turn Signal Lamp, BCM
RKE	10A	Burglar Alarm Horn, Keyless Entry Receiver, BCM
POWER CONNECTOR (ROOM)	15A	Map Lamp, Room Lamp, Sunroof Switch, Instrument Cluster, Data Link Connector, Door Warning Switch, A/C Control Module, Digital Clock, Audio, Power Antenna, Luggage Lamp, Door Lamp, BCM
RR/HTR	30A	Rear Defogger
HTD/MIRR	10A	Power Outside Mirror Motor, A/C Control Module, ECM (G4FC), Instrument Cluster
A/CON	10A	Electro Chromic Mirror, Sunroof Motor, Blower Relay, A/C Control Module, Active Incar & Humidity Sensor, BCM
S/HTR	20A	Front Seat Warmer Switch
R/WIPER	15A	Multifunction Switch, Rear Wiper Relay, Rear Wiper Motor
IGN	10A	Head Lamp Relay (HIGH/LOW), AQS Sensor, Diesel Box (Fuel Filter Heater Relay)
START	10A	BCM, Start Relay, Ignition Lock Switch, Transaxle Range Switch
C/LIGHTER	15A	Power Relay, Cigarette Lighter
AUDIO	10A	Audio, Digital Clock, Power Outside Mirror Switch
SRF/D_LOCK	20A	BCM, Sunroof Motor
CLUSTER	10A	Instrument Cluster, TCS Switch, Auto Light Control Module, BCM, Generator, Resistor
A/BAG	15A	Instrument Cluster, SRS Control Module, PAB Cut Off Switch
ABS	10A	ABS Control Module
ECU	10A	Multifunction Switch (G4GC), Pulse Generator, Transaxle Range Switch, Back-up Lamp Switch, Vehicle Speed Sensor, Fuel Filter Warning Switch (D4FB), Cruise Control Module (G4GC), Stop Lamp Switch (G4GC), Condenser (G4FC), Ignition Coil #1~#4 (G4FC), Air Flow Sensor (D4FB), ECM, TCM
T/SIG	10A	Multifunction Switch
P/WDW LH	25A	Rear Power Window Switch LH, Safety Power Window Module, Safety Power Window Switch, Power Window Main Switch
P/WDW RH	25A	Power Window Main Switch, Safety Power Window Switch, Rear Power Window Switch RH, Passenger Power Window Switch
POWER	15A	Power Outlet
TAIL RH	10A	Front Position Lamp RH, SHUNT, DRL Relay, Front Fog Lamp Relay, Rear Combination Lamp RH
TAIL LH	10A	License Lamp, Rear Combination Lamp LH, Front Position Lamp LH

**✘ USE THE DESIGNATED FUSE ONLY**

FUSE & RELAY INFORMATION

FUSE & RELAY INFORMATION (3)

SD100-3

E/R JUNCTION BOX

1. USE THE DESIGNATED FUSE AND RELAY ONLY.
2. REFER TO OWNER'S MANUAL FOR FUSE AND RELAY SERVICE.
3. NON DRL FUNCTION VEHICLE USE SHUNT RELAY.
4. TO REMOVE OR INSERT FUSE, USE THE FUSE PULLER IN THE DASH FUSE BOX PANEL.
5. ( ): OPTION.

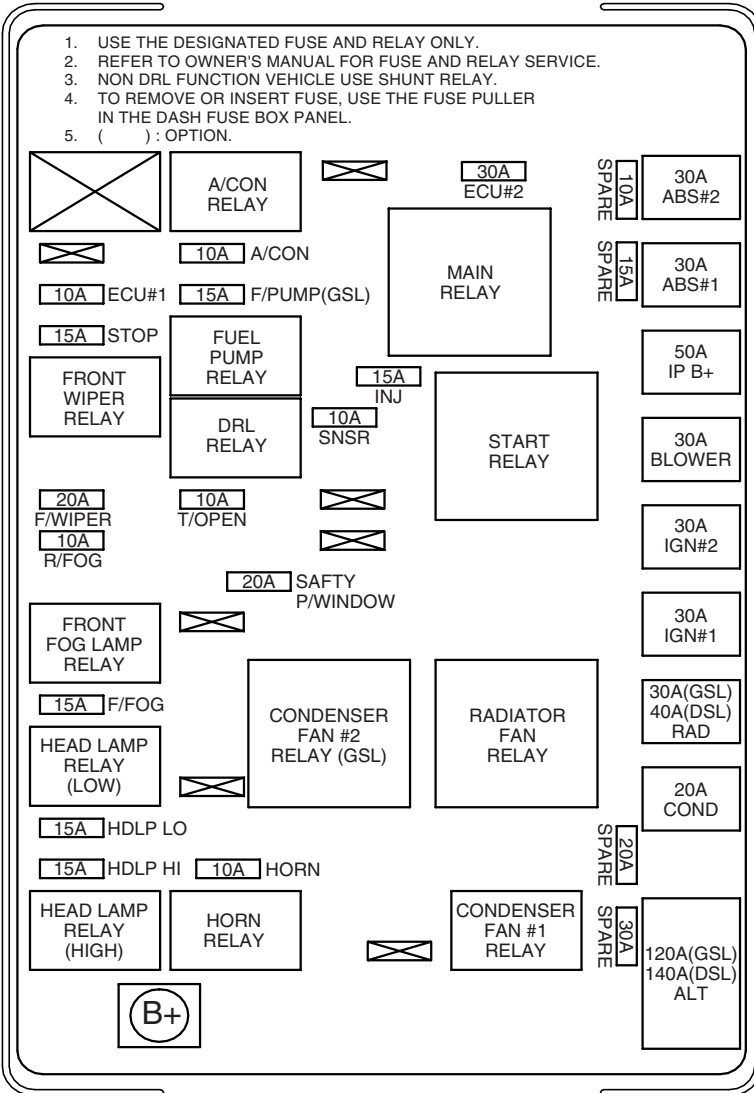

CIRCUIT

	Description	(A)	Circuit Protected
FUSE	ECU #1	10A	Multipurpose Check Connector (G4FC/D4FB), TCM (D4FB)
	STOP	15A	Stop Lamp Switch
	F/WIPER	20A	Front Wiper Relay, Multifunction Switch, Front Wiper Motor
	R/FOG	10A	Rear Fog Lamp Relay
	F/FOG	15A	Front Fog Lamp Relay
	HDLP LO	15A	Head Lamp Relay (Low)
	HDLP HI	15A	Head Lamp Relay (High)
	A/CON	10A	A/Con Relay
	F/PUMP	15A	Fuel Pump Relay
	T/OPEN	10A	Trunk Lid Open Relay (4DR), DRL Relay
	SAFTY P/WINDOW	20A	Safety Power Window Module
	HORN	10A	Horn Relay
	INJ	15A	Injector #1~#4 (G4FC/G4GC), Idle Speed Actuator (G4FC/G4GC), Oil Control Valve (G4FC/G4GC), Purge Control Solenoid Valve (G4GC), EGR Actuator (D4FB), Camshaft Position Sensor (D4FB), VGT Actuator (D4FB), Stop Lamp Switch (D4FB), Diesel Box (D4FB)
	SNSR	10A	Oxygen Sensor (G4FC/G4GC), Purge Control Solenoid Valve (G4FC), Immobilizer Control Module, Camshaft Position Sensor (G4FC/G4GC), Crankshaft Position Sensor (G4GC), Lambda Sensor (D4FB), ECM
FUSIBLE LINK	ECU #2	30A	Main Relay, ECM (G4FC/G4GC), Multipurpose Check Connector (G4GC)
	ABS #2	30A	ABS Control Module
	ABS #1	30A	ABS Control Module
	IP B+	50A	I/P Junction Box
	BLOWER	30A	Blower Relay
	IGN #2	30A	Start Relay, Ignition Switch
	IGN #1	30A	Ignition Switch
	RAD	30A(GSL) 40A(DSL)	Radiator Fan Relay
	COND	20A	Condenser Fan #1 Relay
	ALT	120A(GSL) 140A(DSL)	Generator

✘ USE THE DESIGNATED FUSE ONLY

FUSE & RELAY INFORMATION

FUSE & RELAY INFORMATION (4)

SD100-4

DIESEL BOX

D4FB

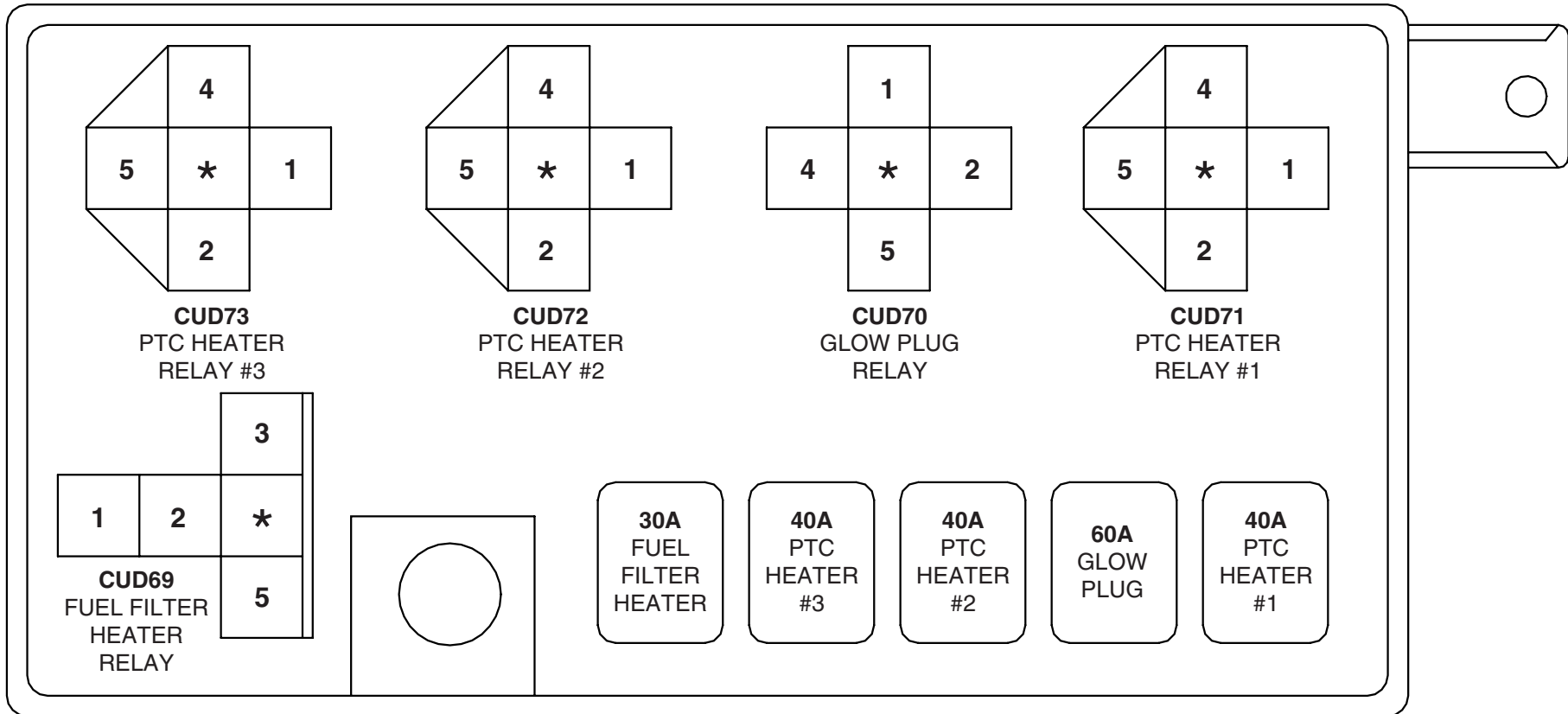

⊗ USE THE DESIGNATED FUSE ONLY

POWER DISTRIBUTION

EA5D91A6

POWER DISTRIBUTION (1)

SD110-1

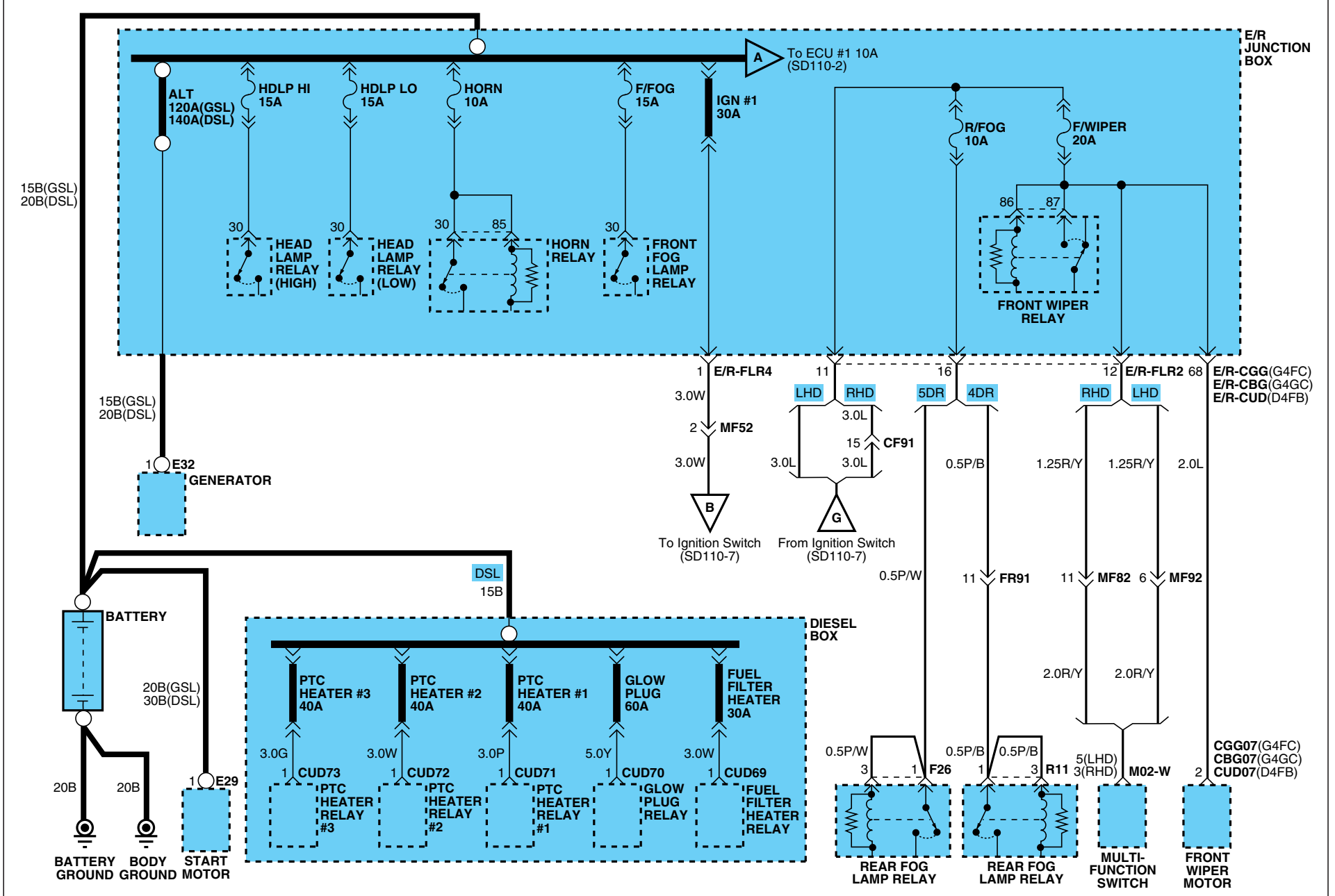

POWER DISTRIBUTION

POWER DISTRIBUTION (2)

SD110-2

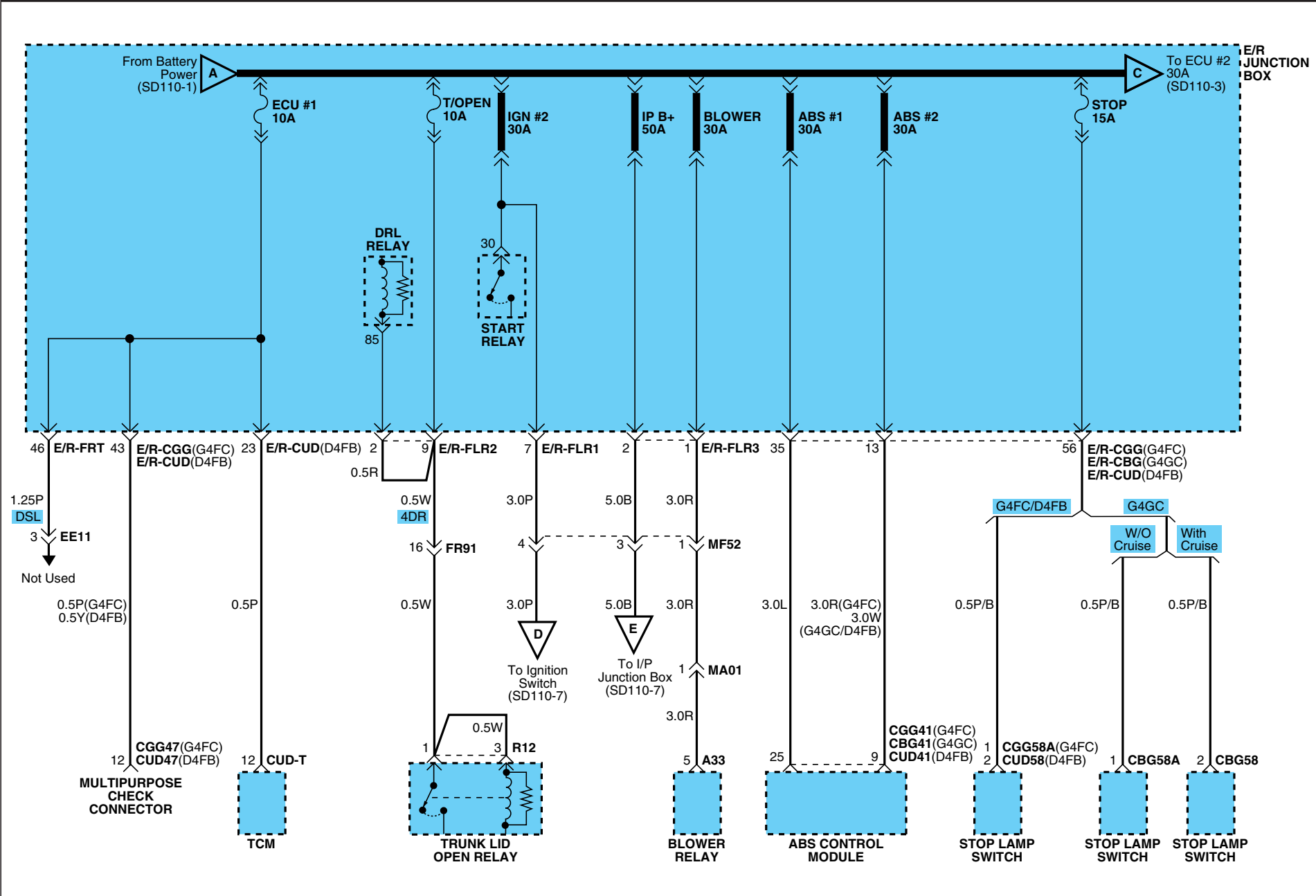

POWER DISTRIBUTION

POWER DISTRIBUTION (3)

SD110-3

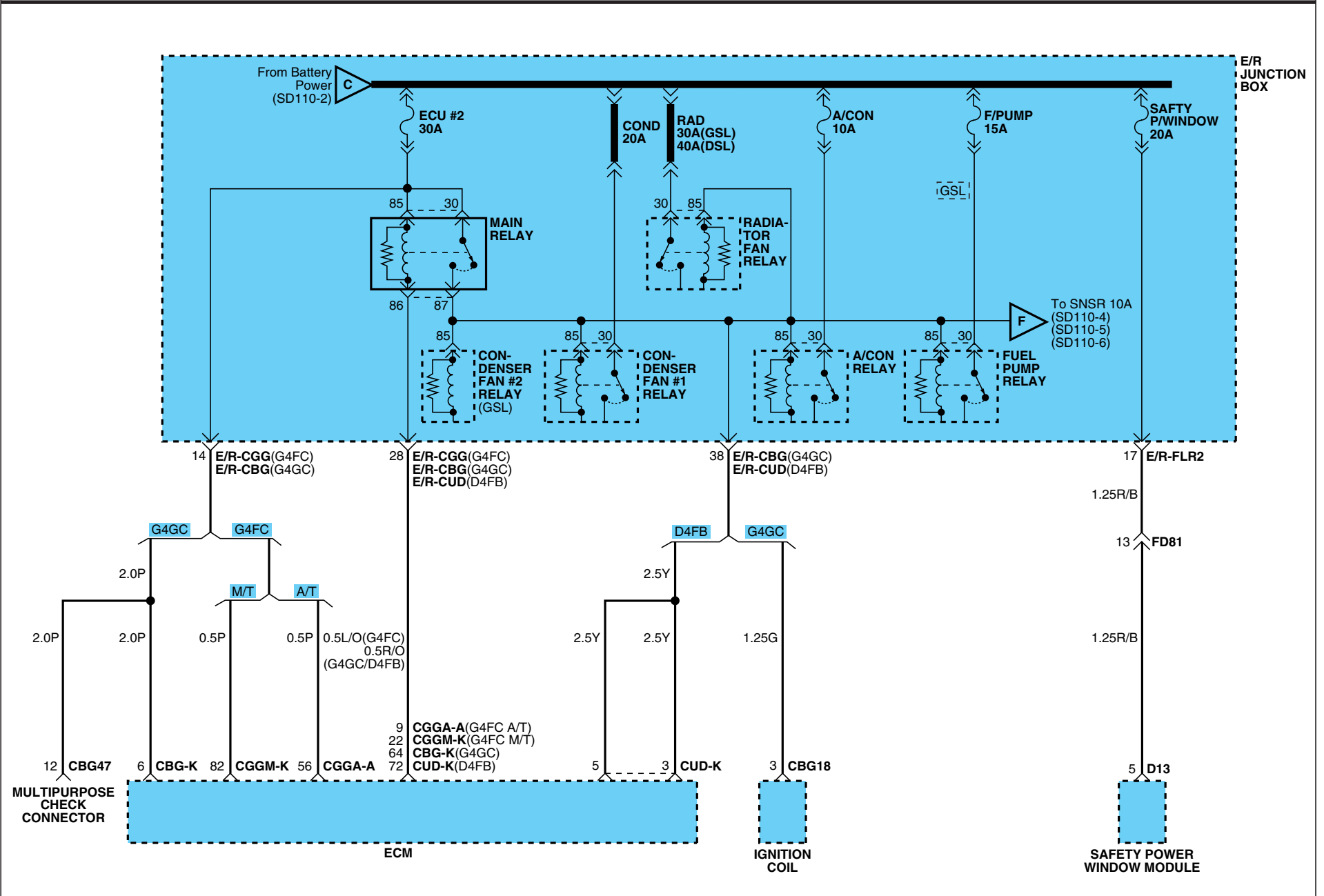

POWER DISTRIBUTION

POWER DISTRIBUTION (4)

SD110-4

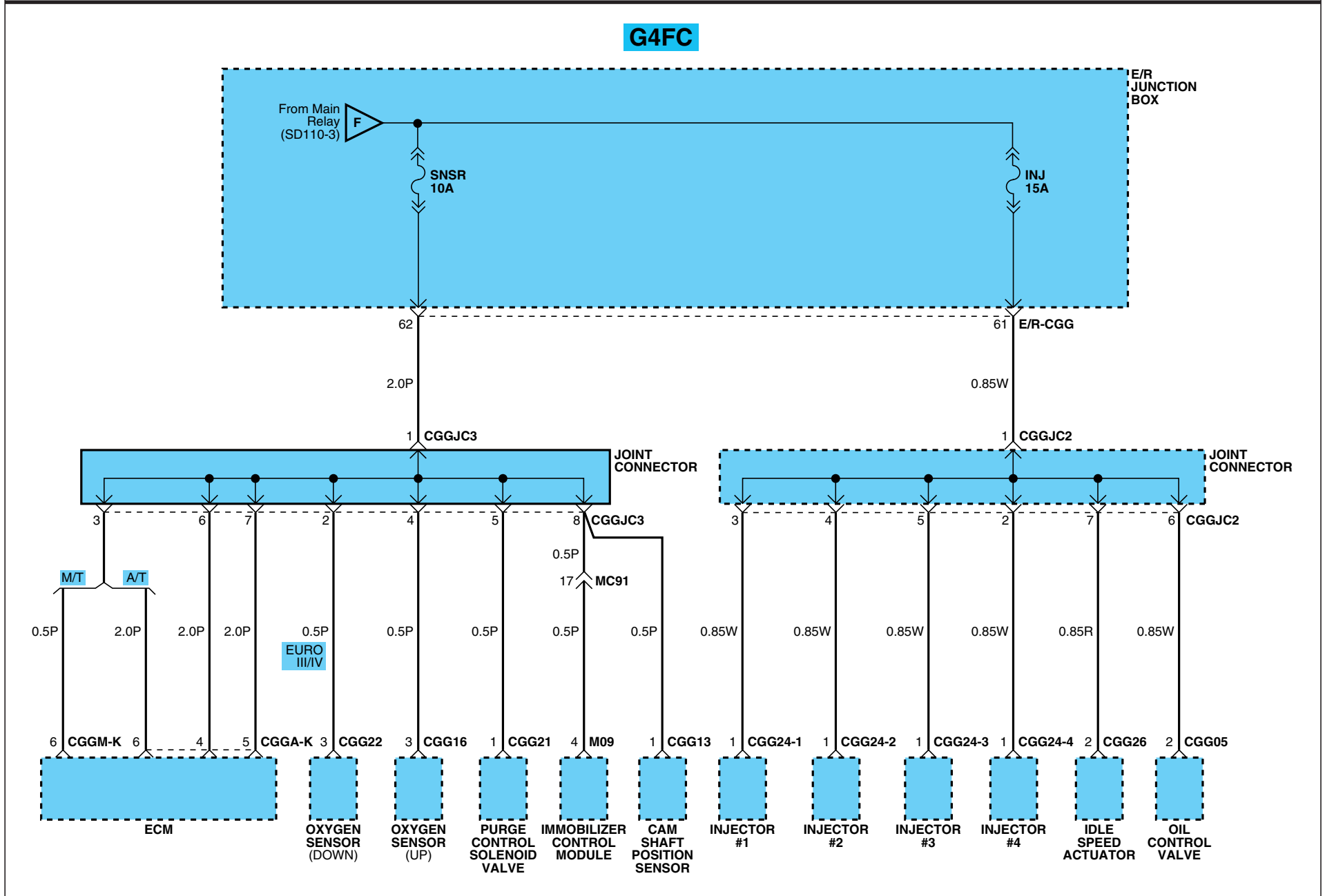

POWER DISTRIBUTION

POWER DISTRIBUTION (5)

SD110-5

G4GC

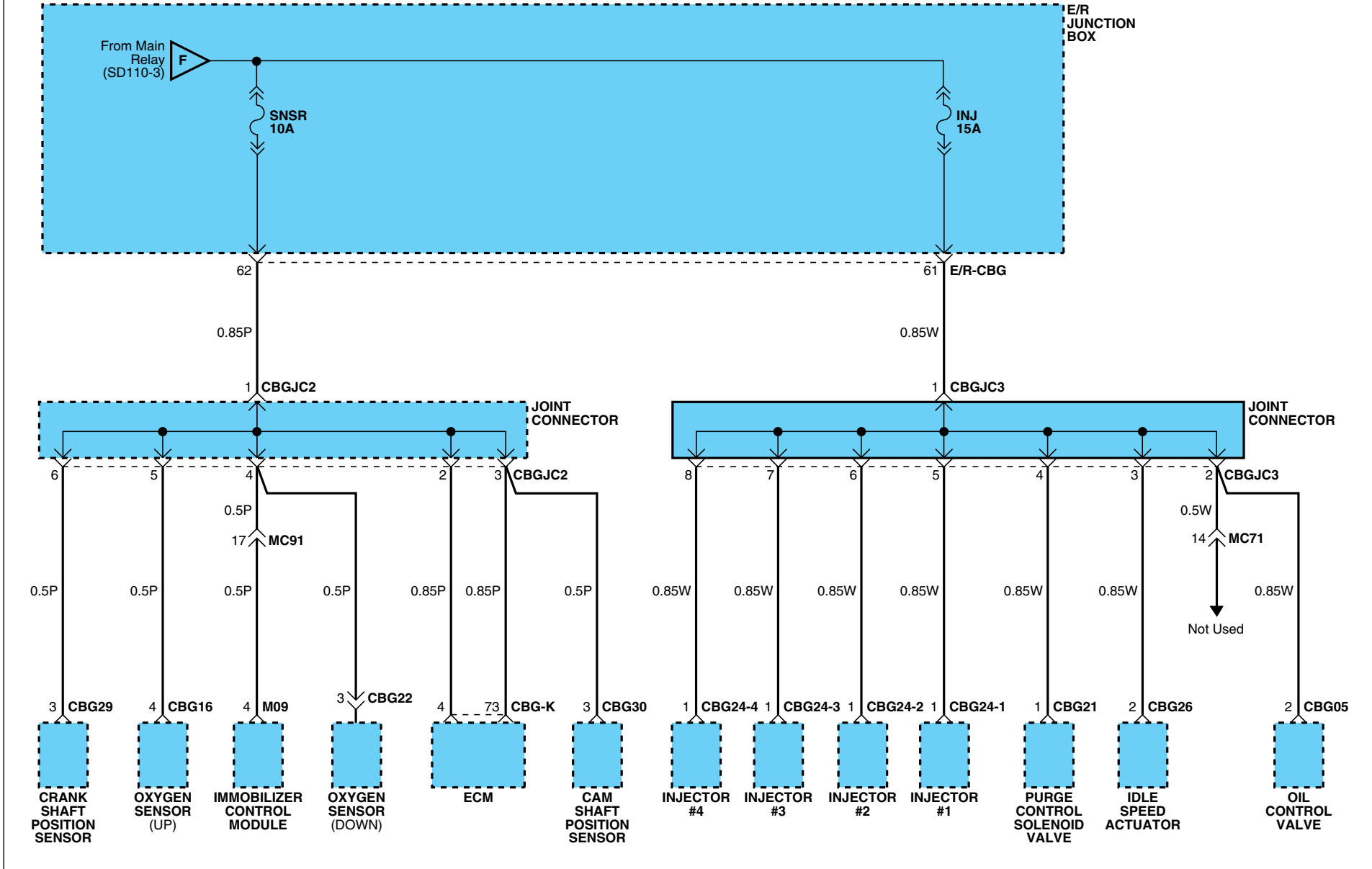



POWER DISTRIBUTION

POWER DISTRIBUTION (6)

SD110-6

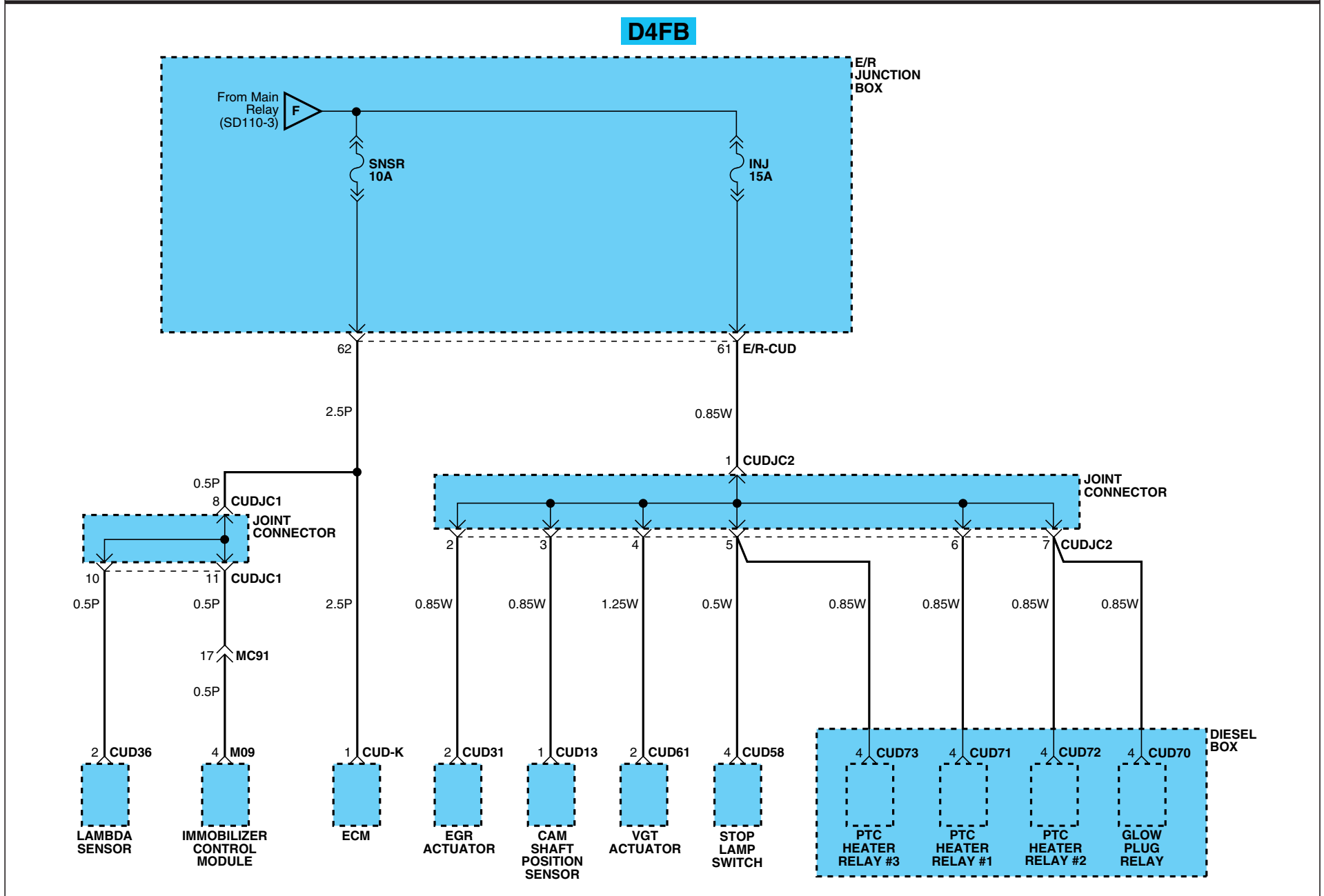

# POWER DISTRIBUTION

## POWER DISTRIBUTION (7)

SD110-7

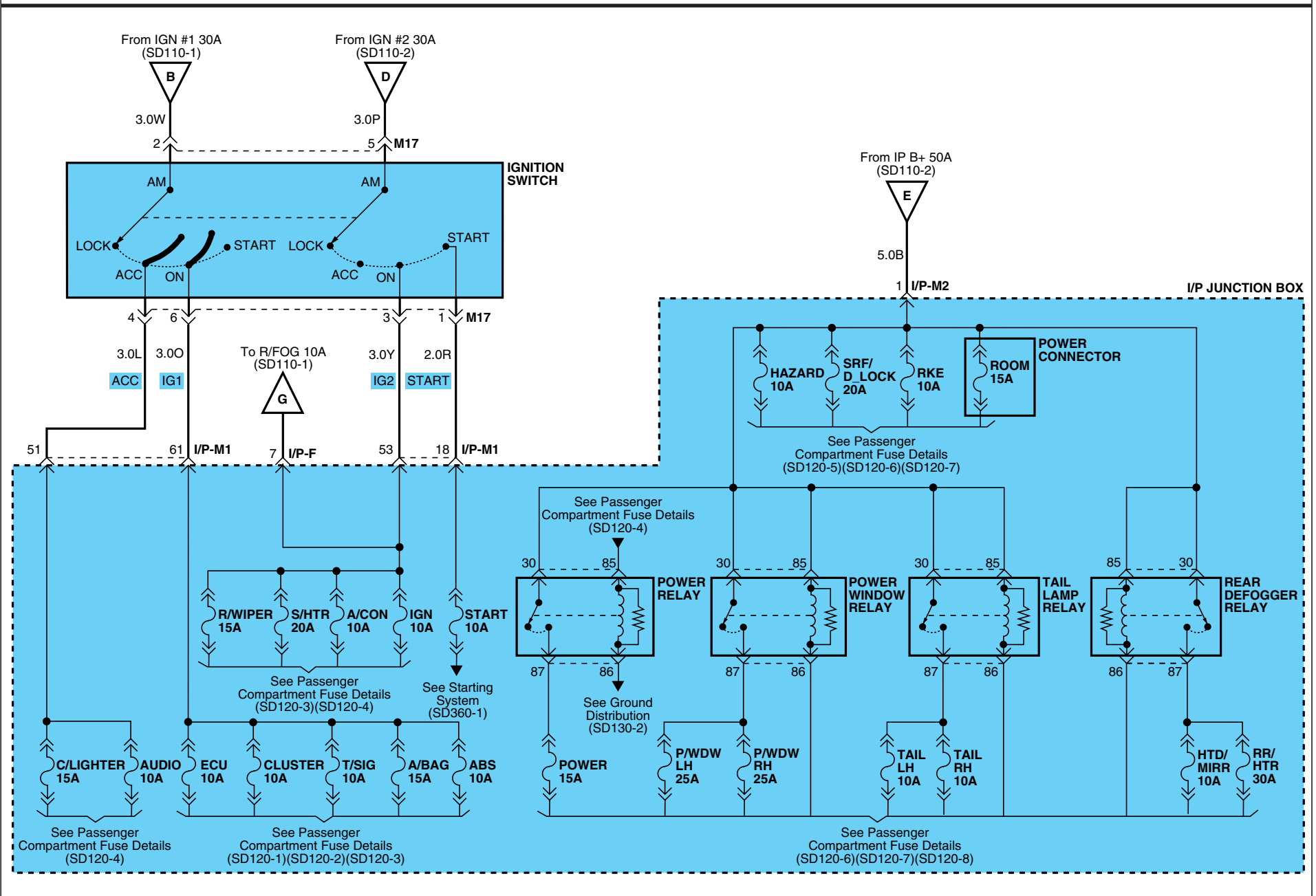

**POWER DISTRIBUTION**

**POWER DISTRIBUTION (8)**

**SD110-8**

**MEMO**

PASSENGER COMPARTMENT FUSE DETAILS E0FC3C07

PASSENGER COMPARTMENT FUSE DETAILS (1)

SD120-1

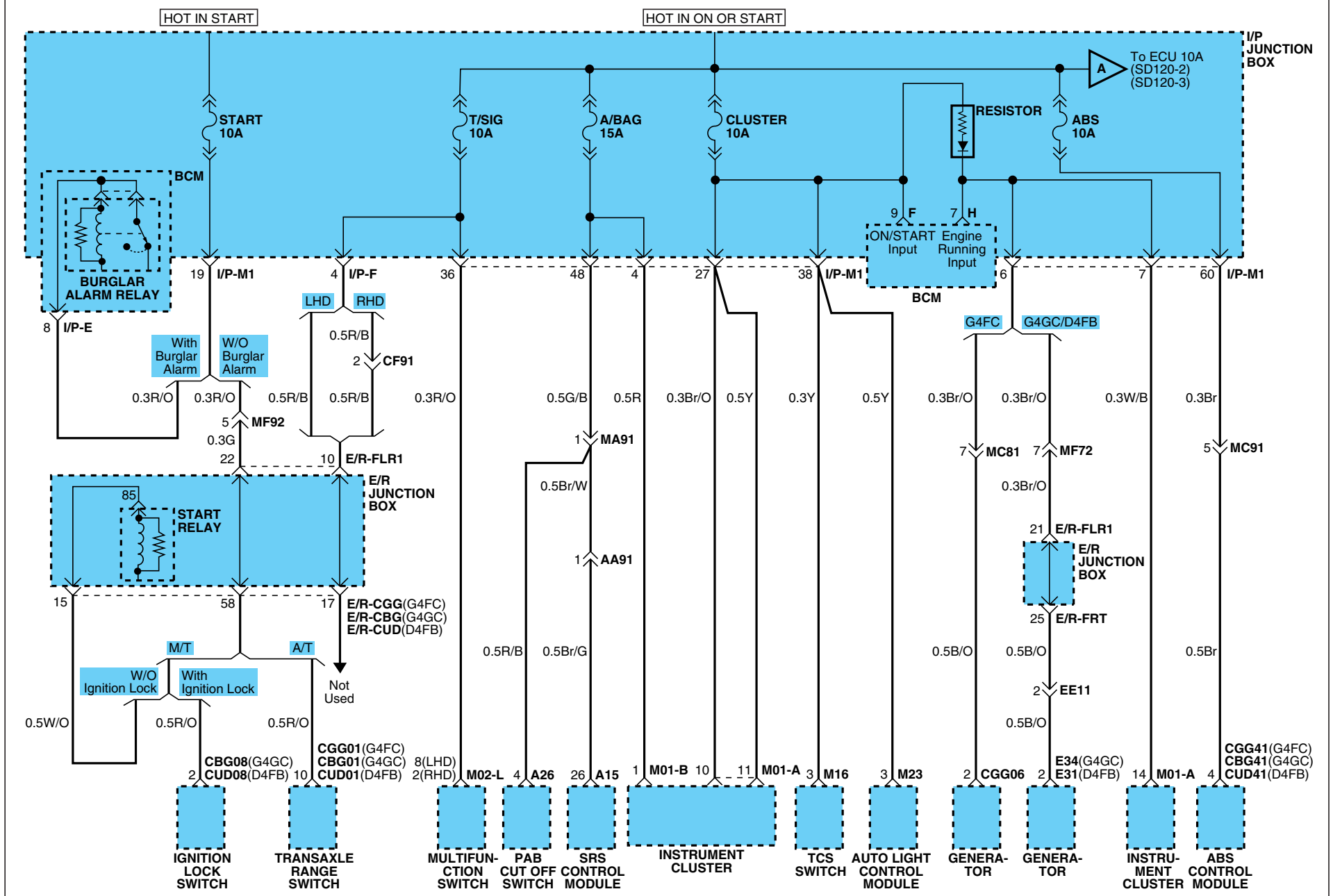

# PASSENGER COMPARTMENT FUSE DETAILS

## PASSENGER COMPARTMENT FUSE DETAILS (2)

SD120-2

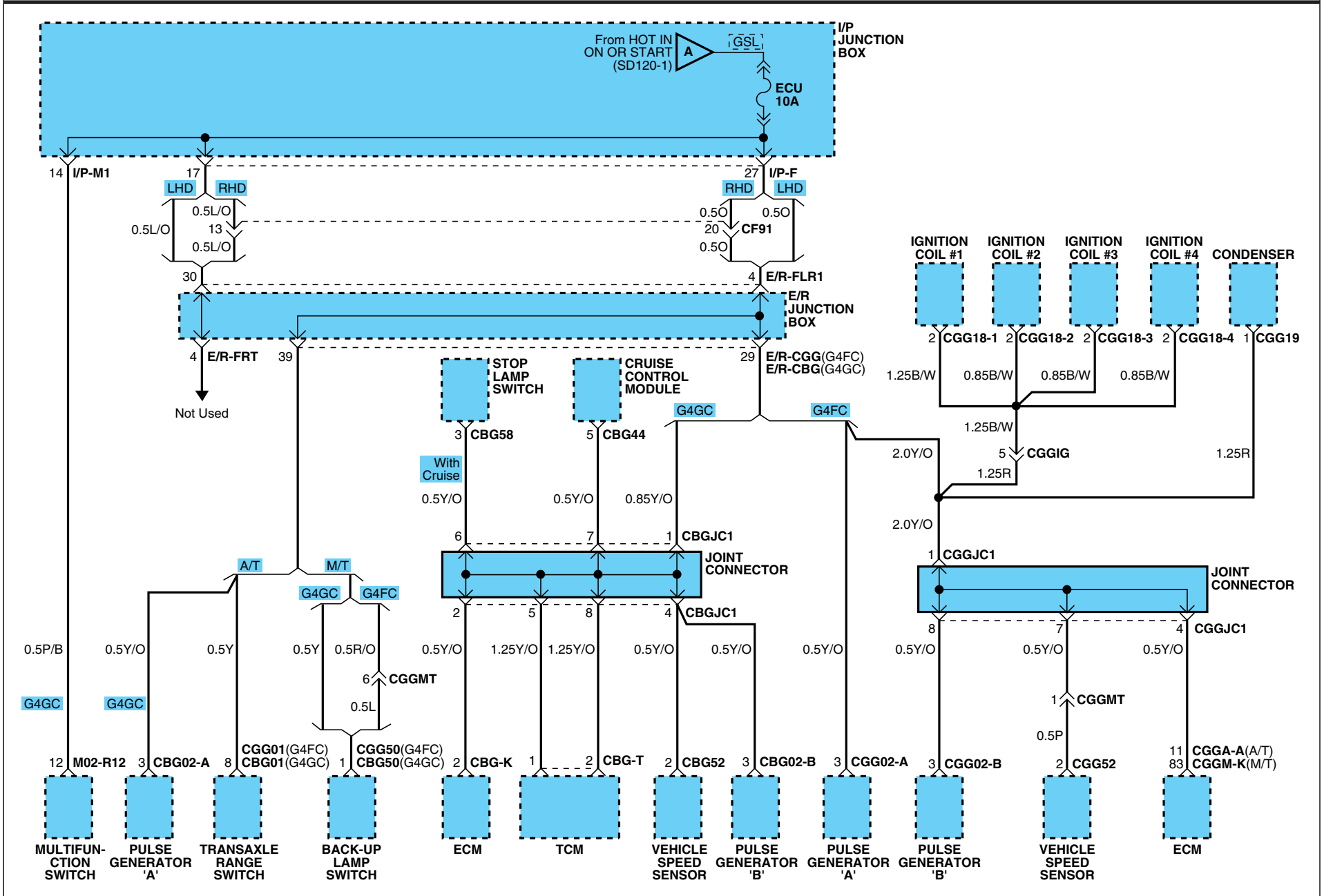

PASSENGER COMPARTMENT FUSE DETAILS

PASSENGER COMPARTMENT FUSE DETAILS (3)

SD120-3

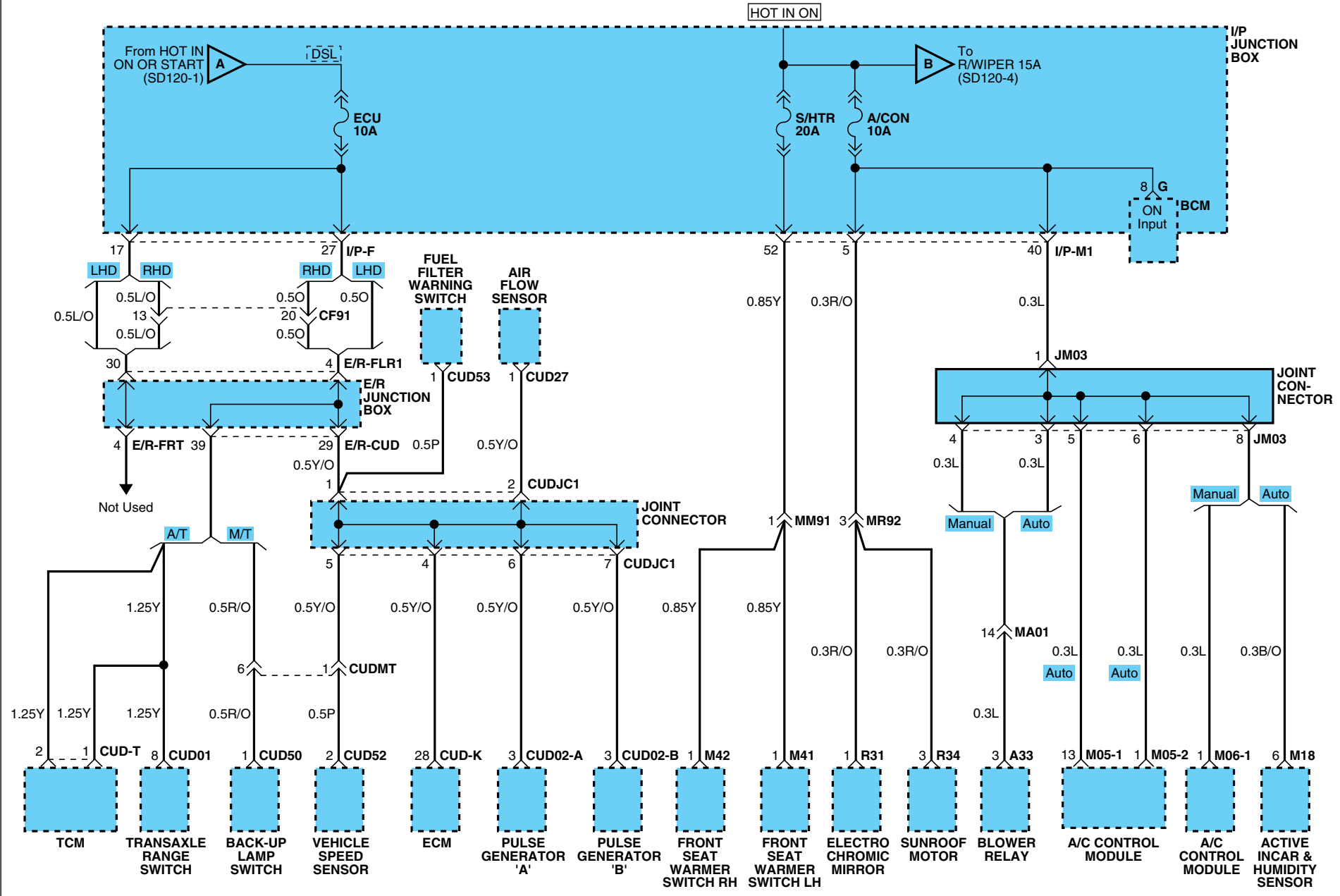

# PASSENGER COMPARTMENT FUSE DETAILS

## PASSENGER COMPARTMENT FUSE DETAILS (4)

SD120-4

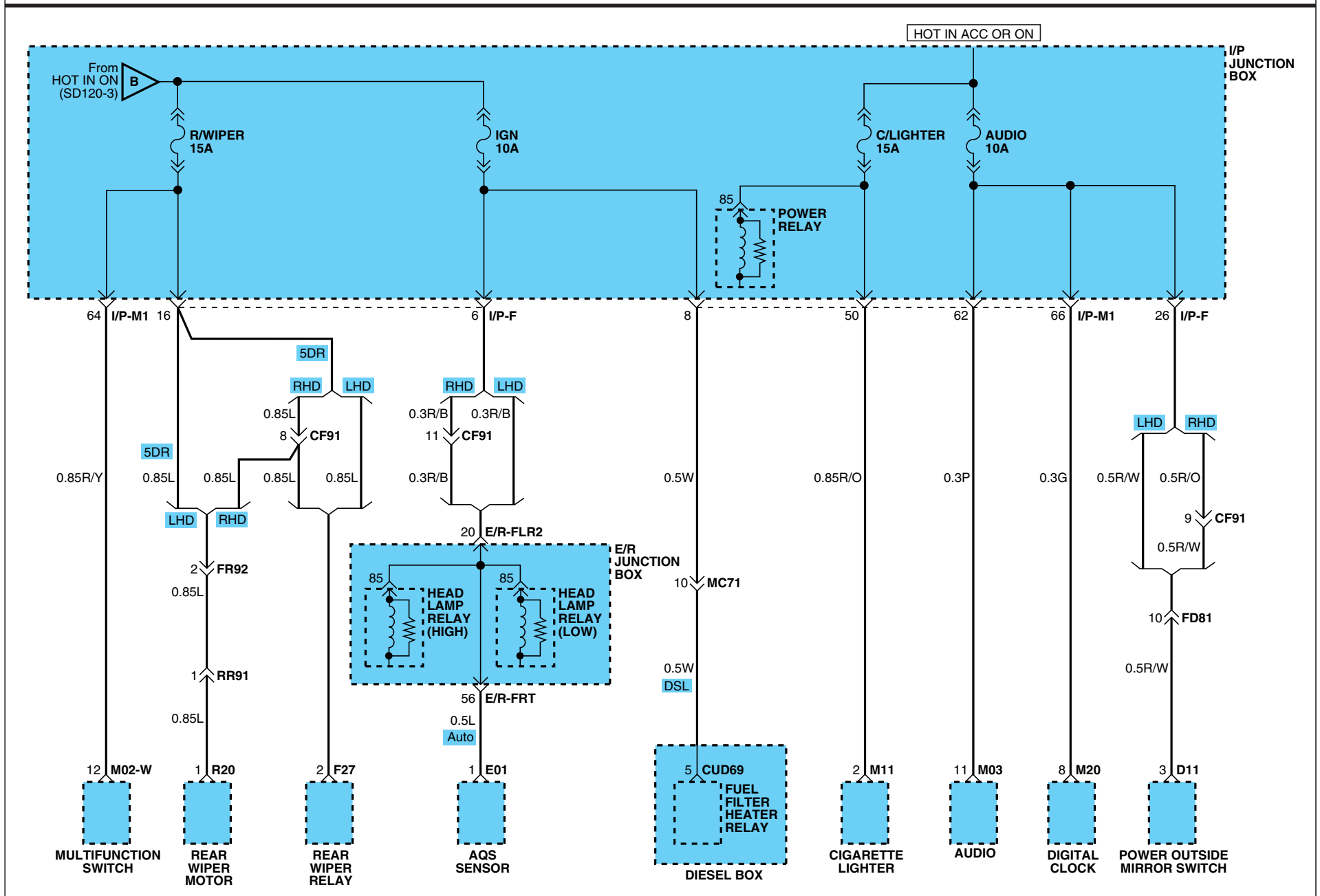

PASSENGER COMPARTMENT FUSE DETAILS

PASSENGER COMPARTMENT FUSE DETAILS (5)

SD120-5

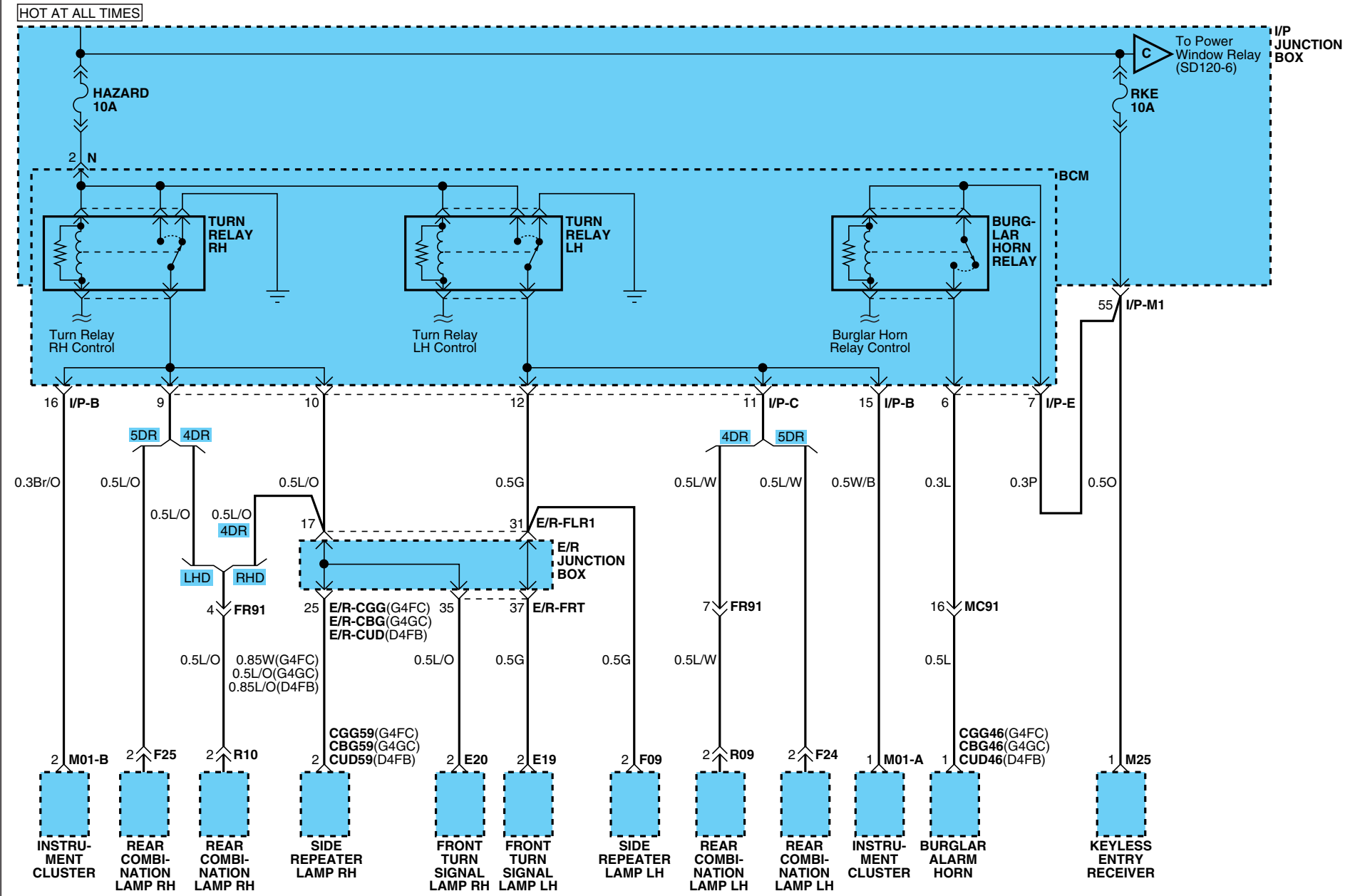



PASSENGER COMPARTMENT FUSE DETAILS

PASSENGER COMPARTMENT FUSE DETAILS (6)

SD120-6

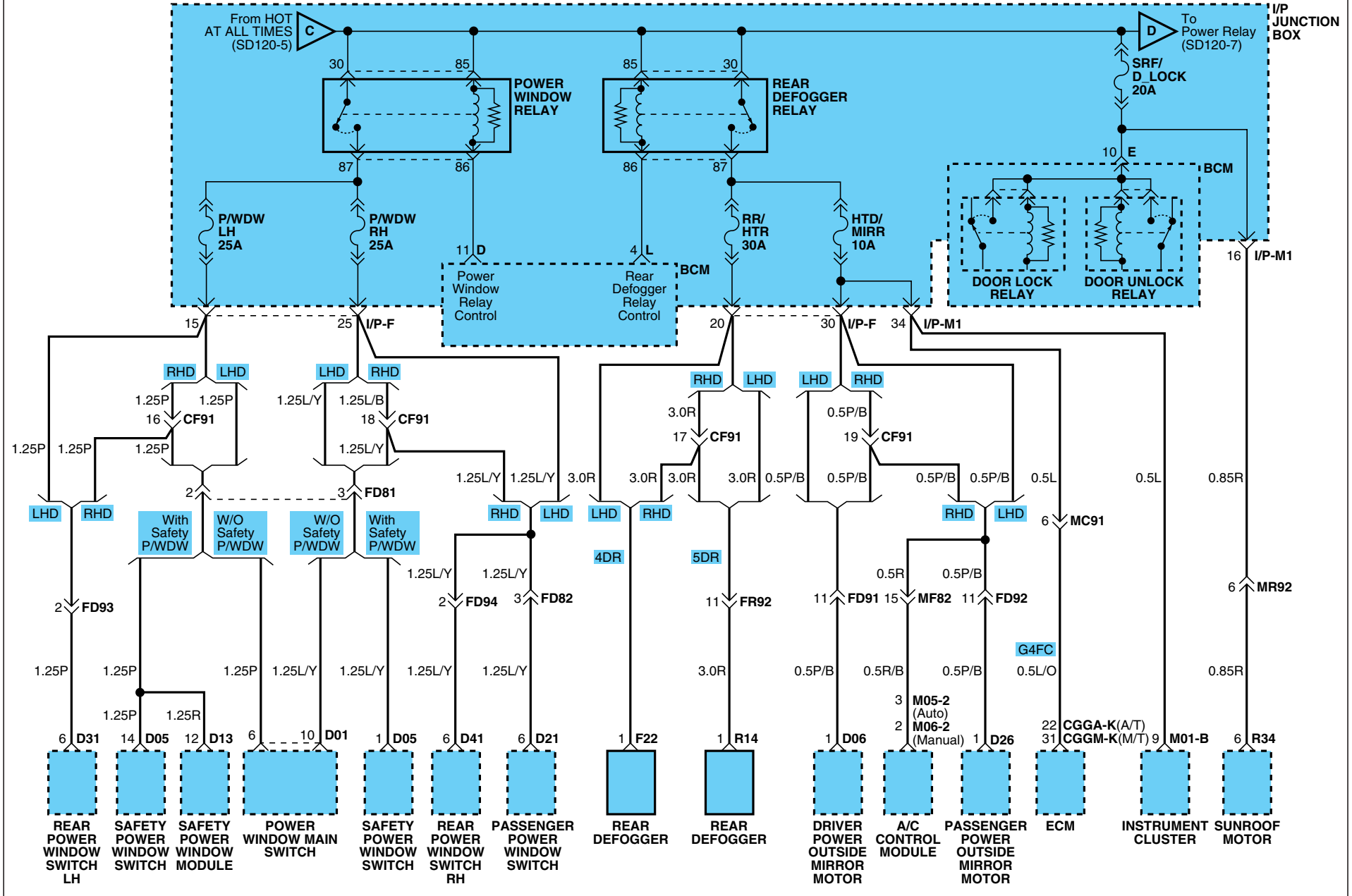

# PASSENGER COMPARTMENT FUSE DETAILS

## PASSENGER COMPARTMENT FUSE DETAILS (7)

SD120-7

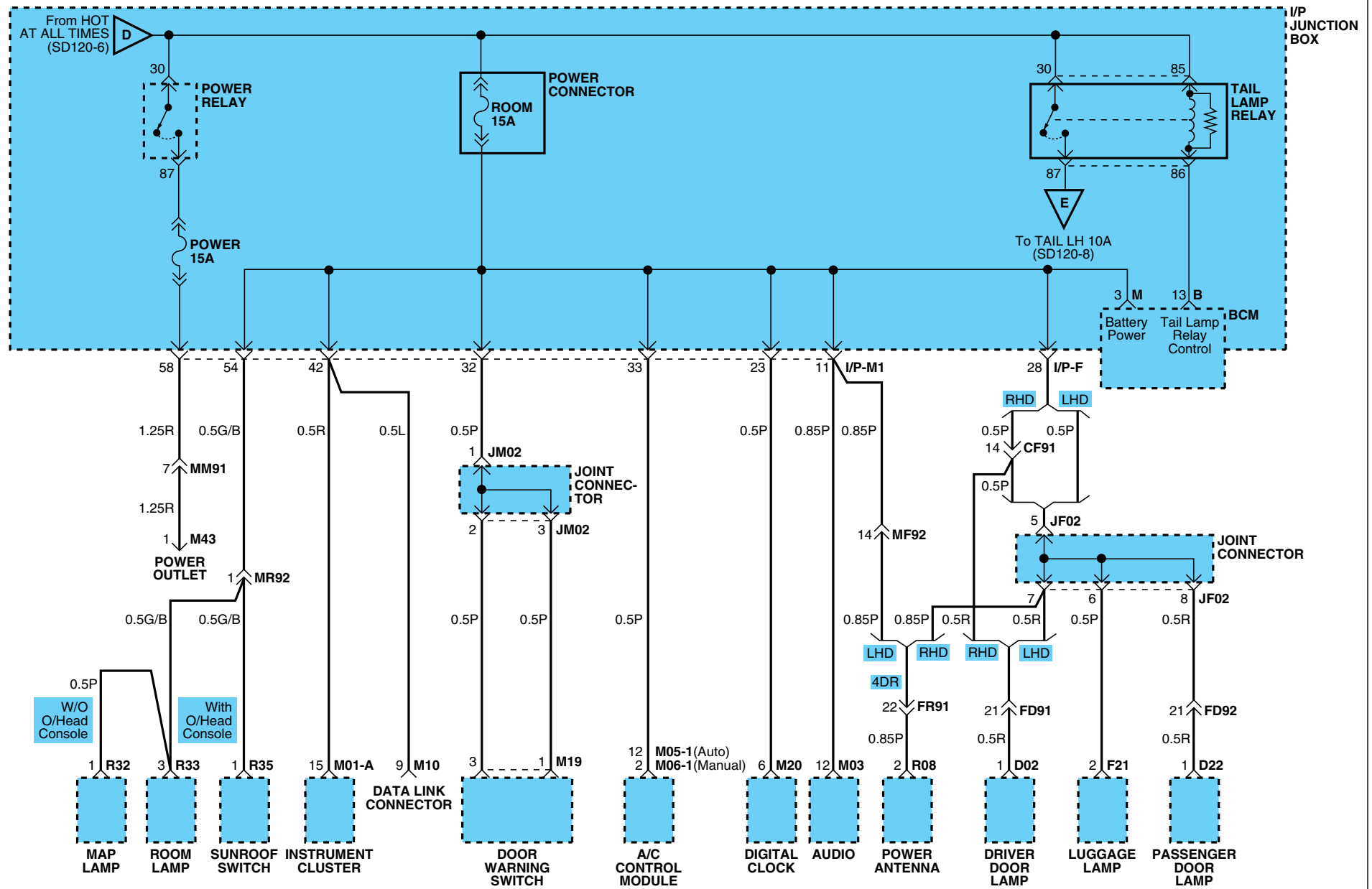

# PASSENGER COMPARTMENT FUSE DETAILS

## PASSENGER COMPARTMENT FUSE DETAILS (8)

SD120-8

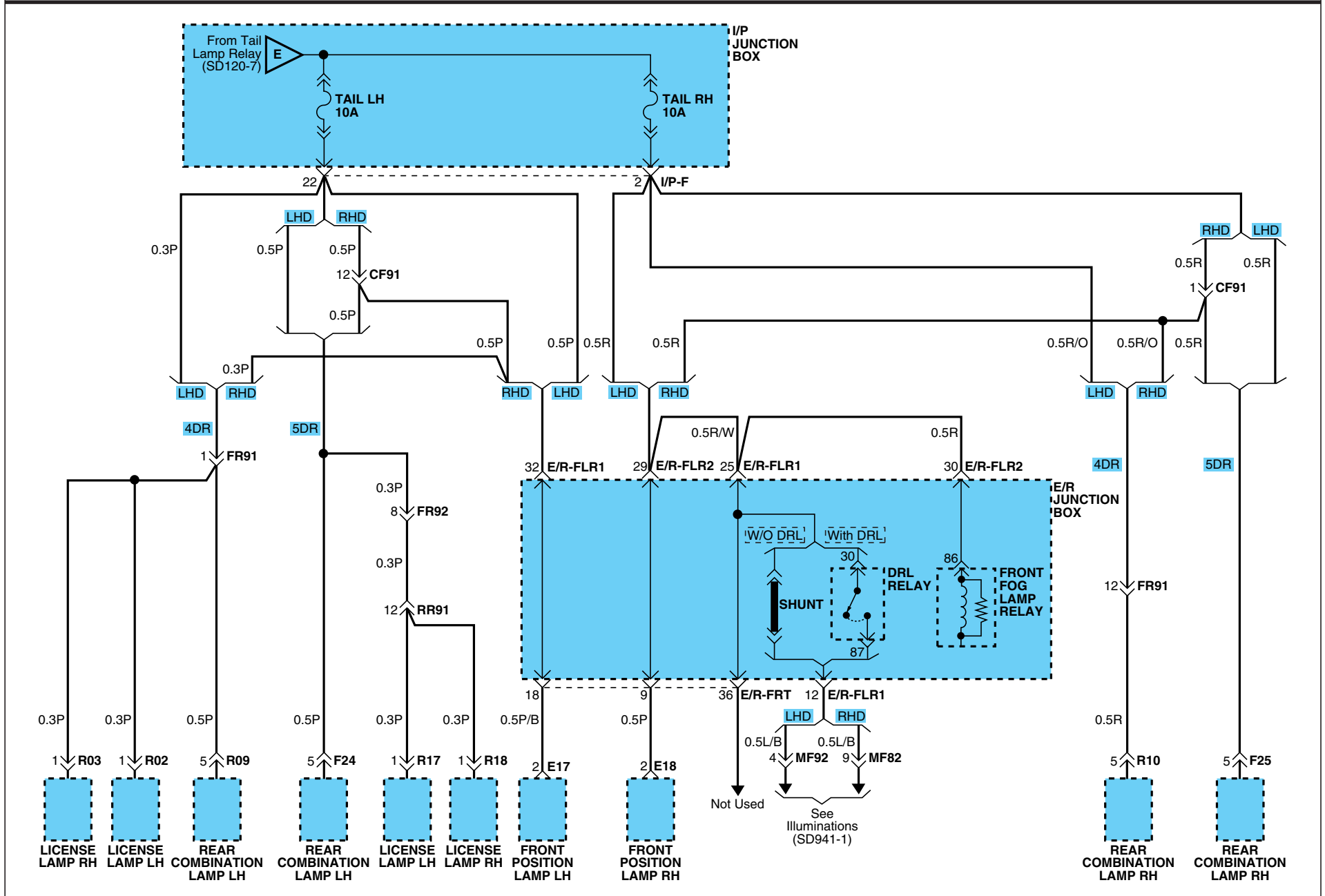

GROUND DISTRIBUTION E2A0EA10

GROUND DISTRIBUTION (1)

SD130-1

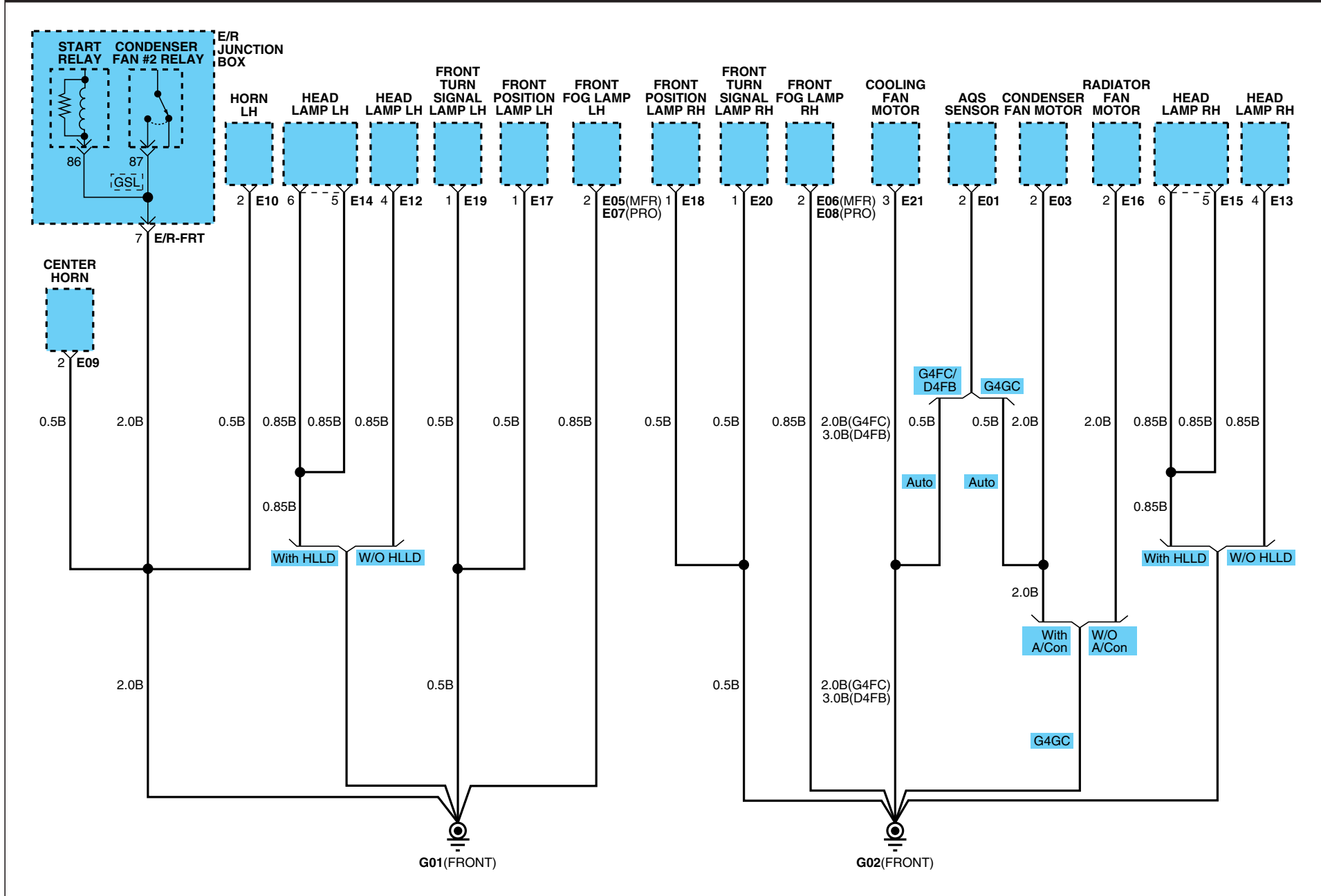

# GROUND DISTRIBUTION

## GROUND DISTRIBUTION (2)

SD130-2

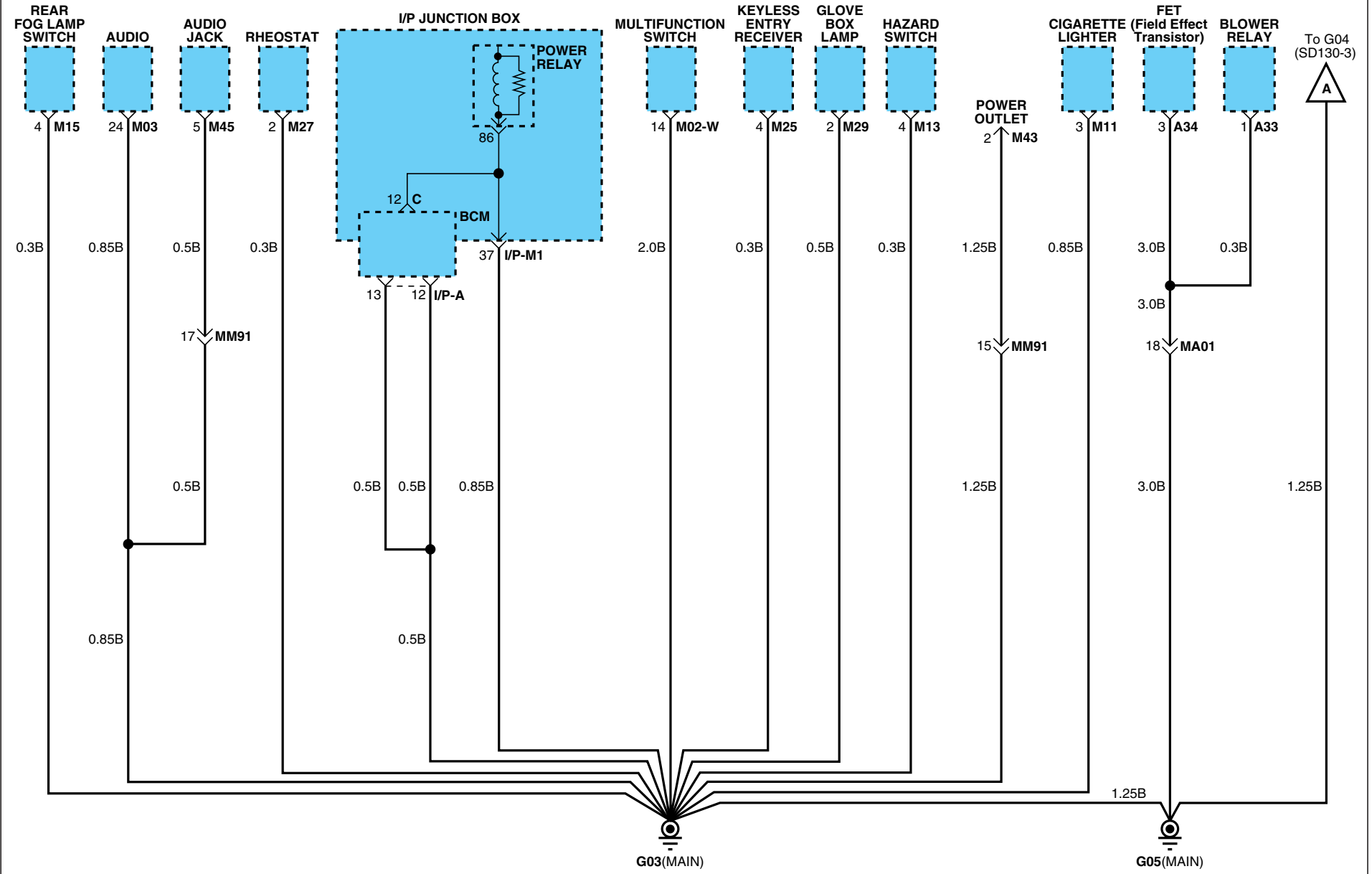

# GROUND DISTRIBUTION

## GROUND DISTRIBUTION (3)

SD130-3

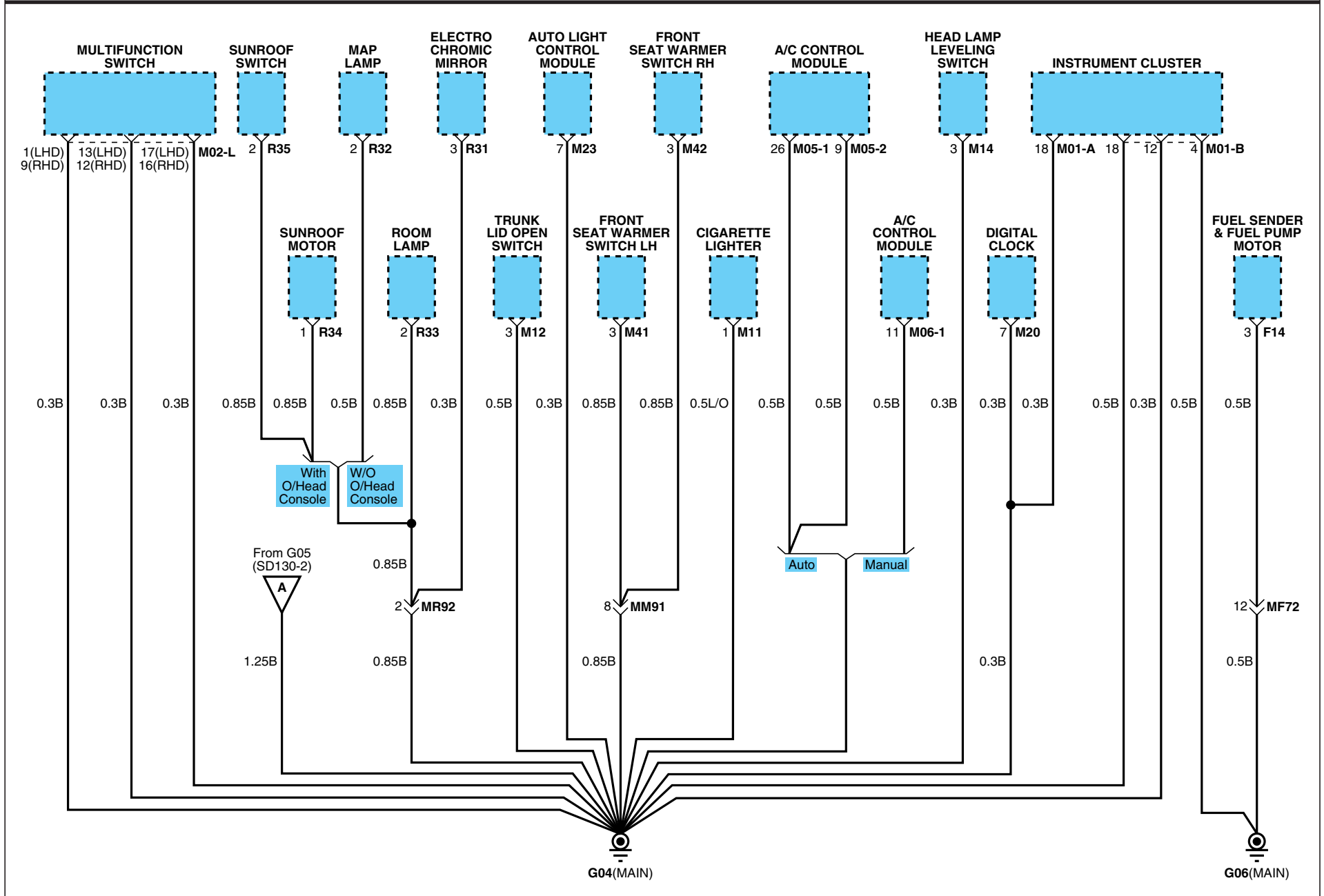

# GROUND DISTRIBUTION

## GROUND DISTRIBUTION (4)

SD130-4

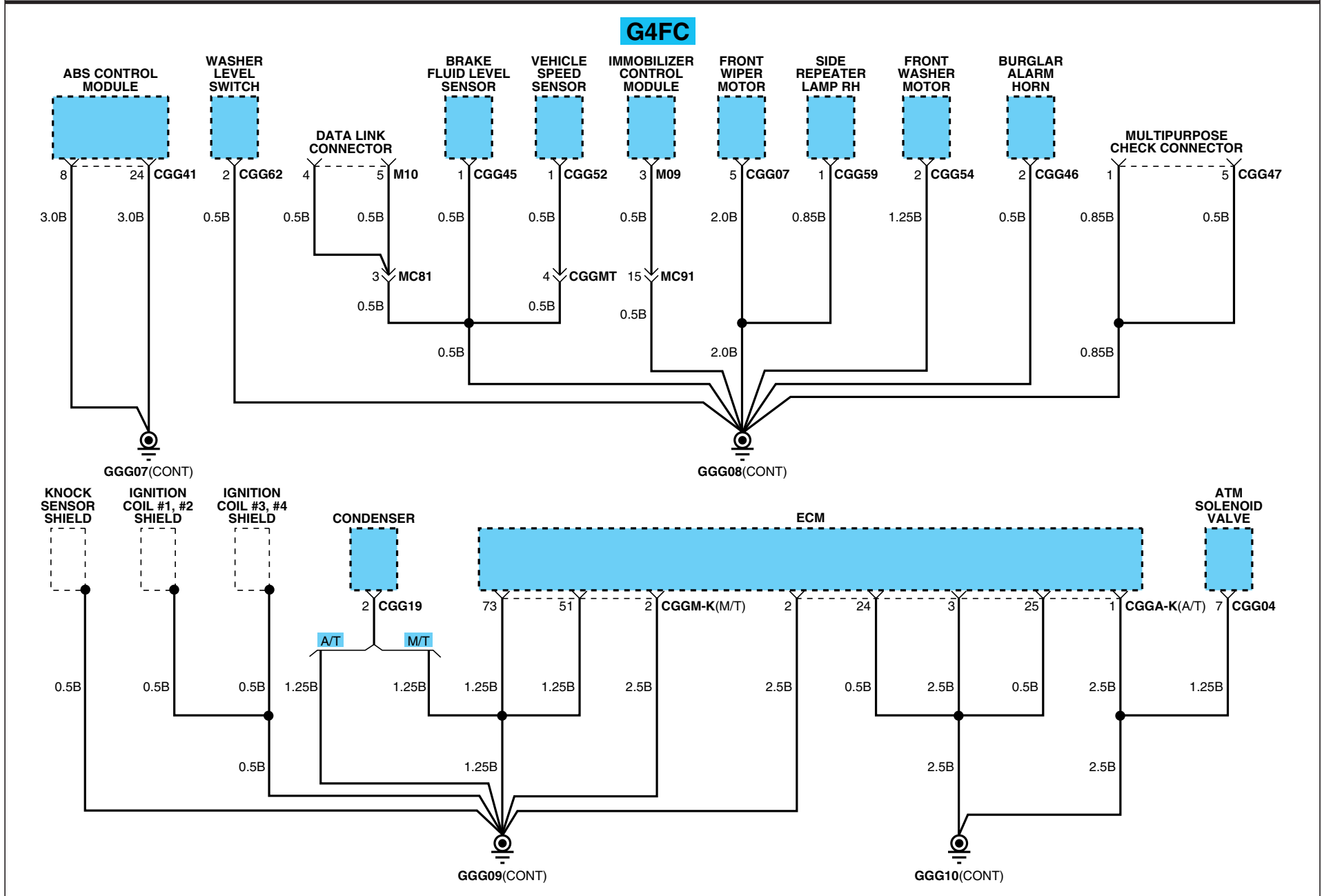

### GROUND DISTRIBUTION

#### GROUND DISTRIBUTION (5)

SD130-5

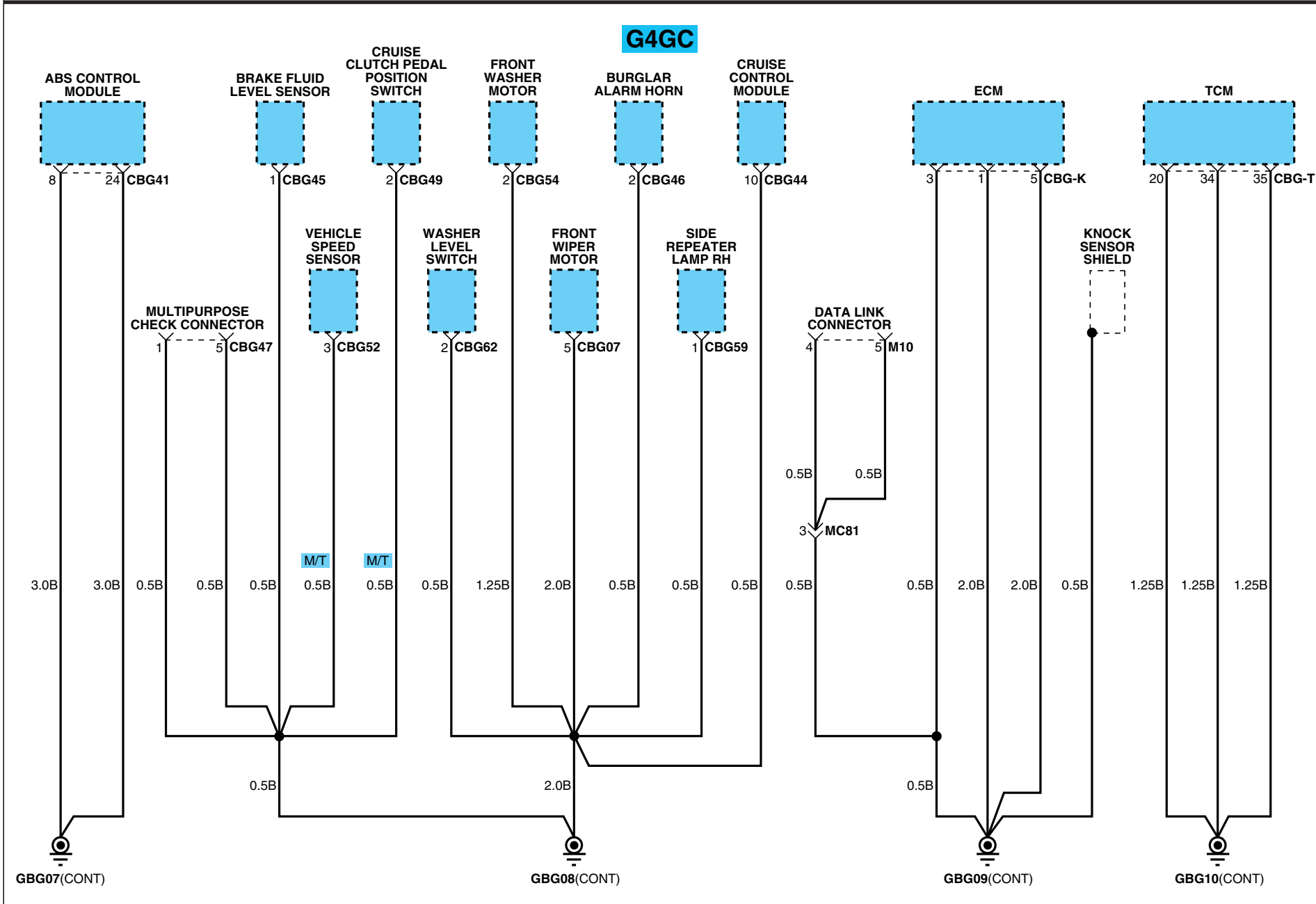



# GROUND DISTRIBUTION

## GROUND DISTRIBUTION (6)

SD130-6

### D4FB

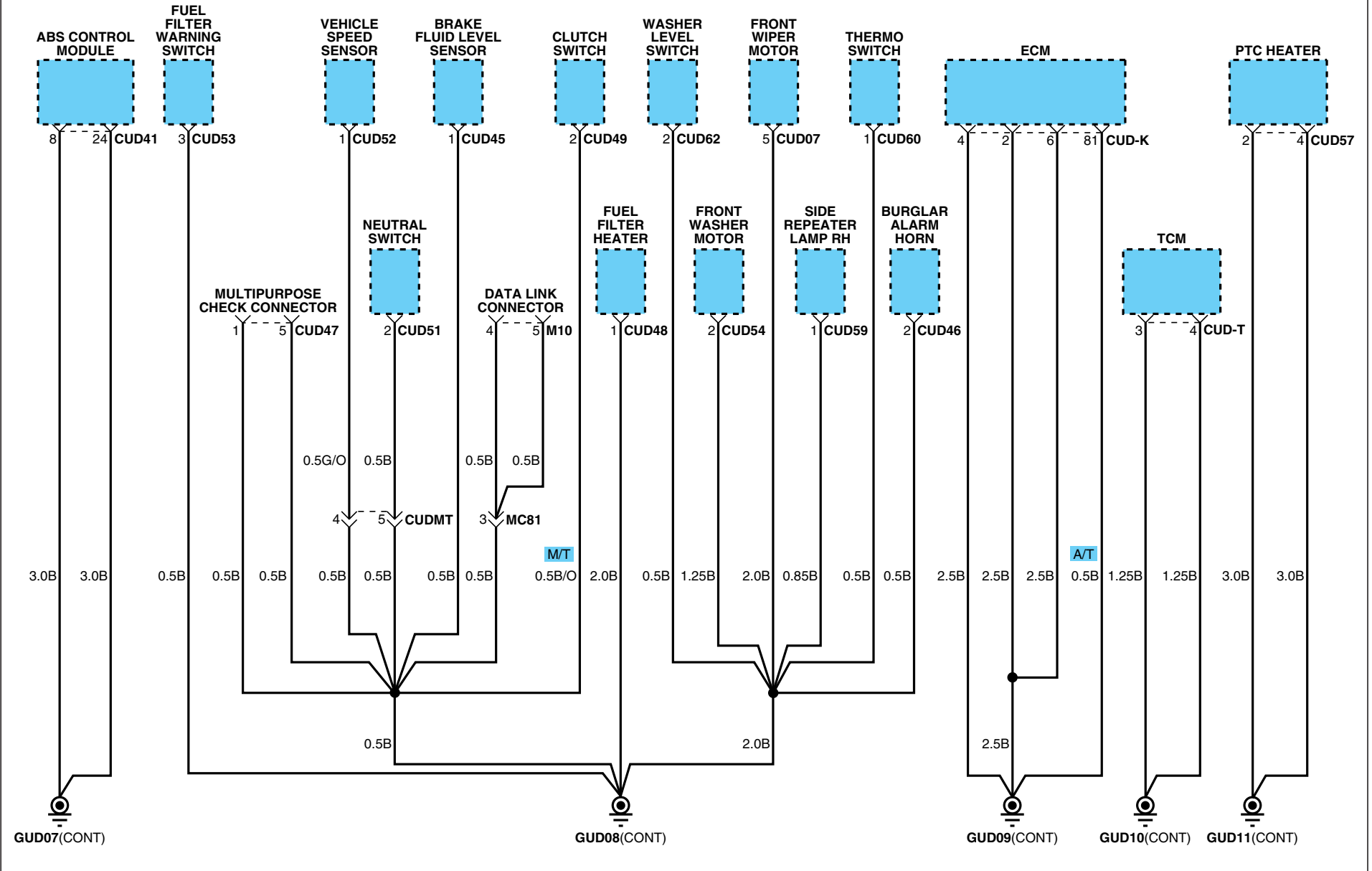

# GROUND DISTRIBUTION

## GROUND DISTRIBUTION (7)

SD130-7

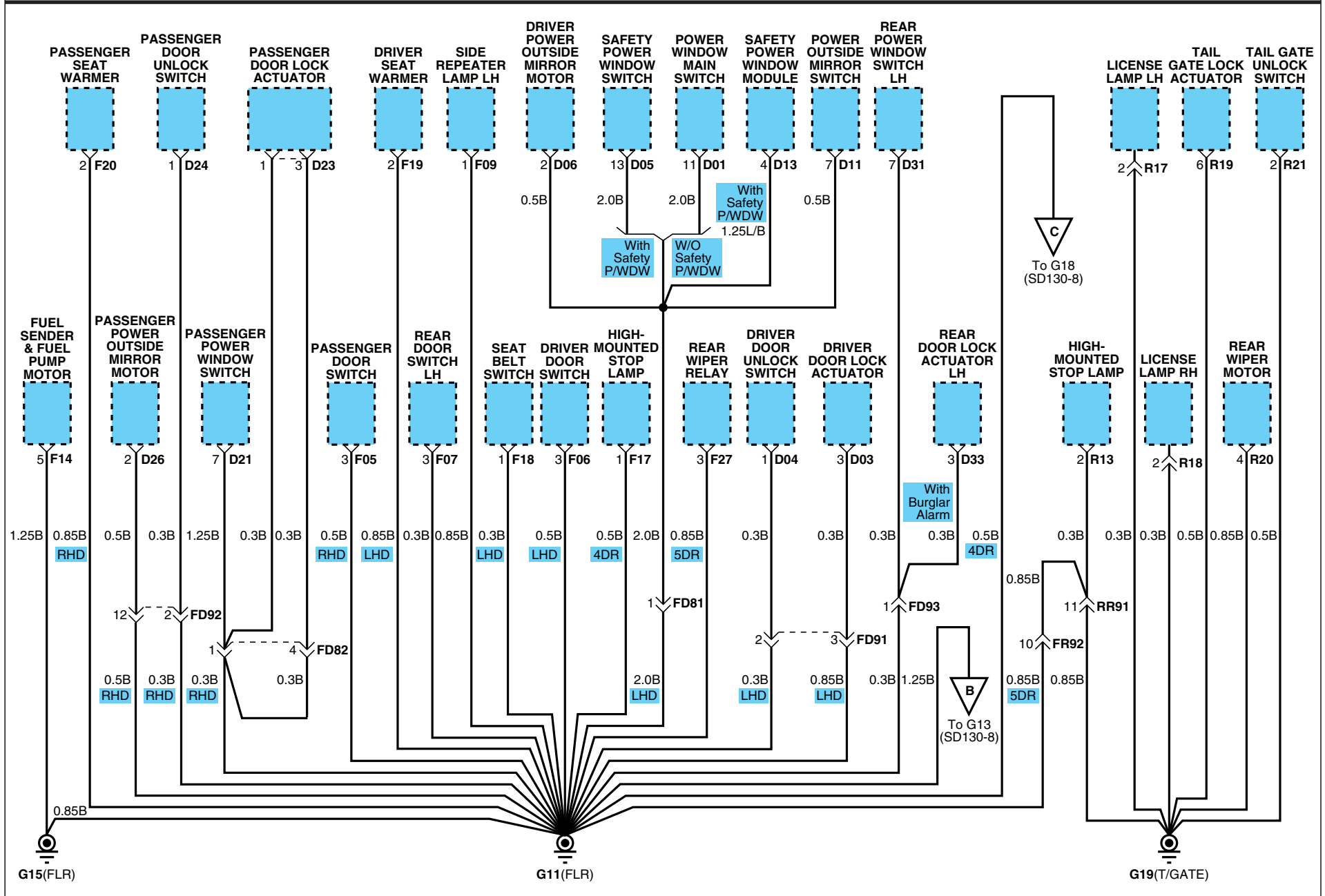

# GROUND DISTRIBUTION

## GROUND DISTRIBUTION (8)

SD130-8

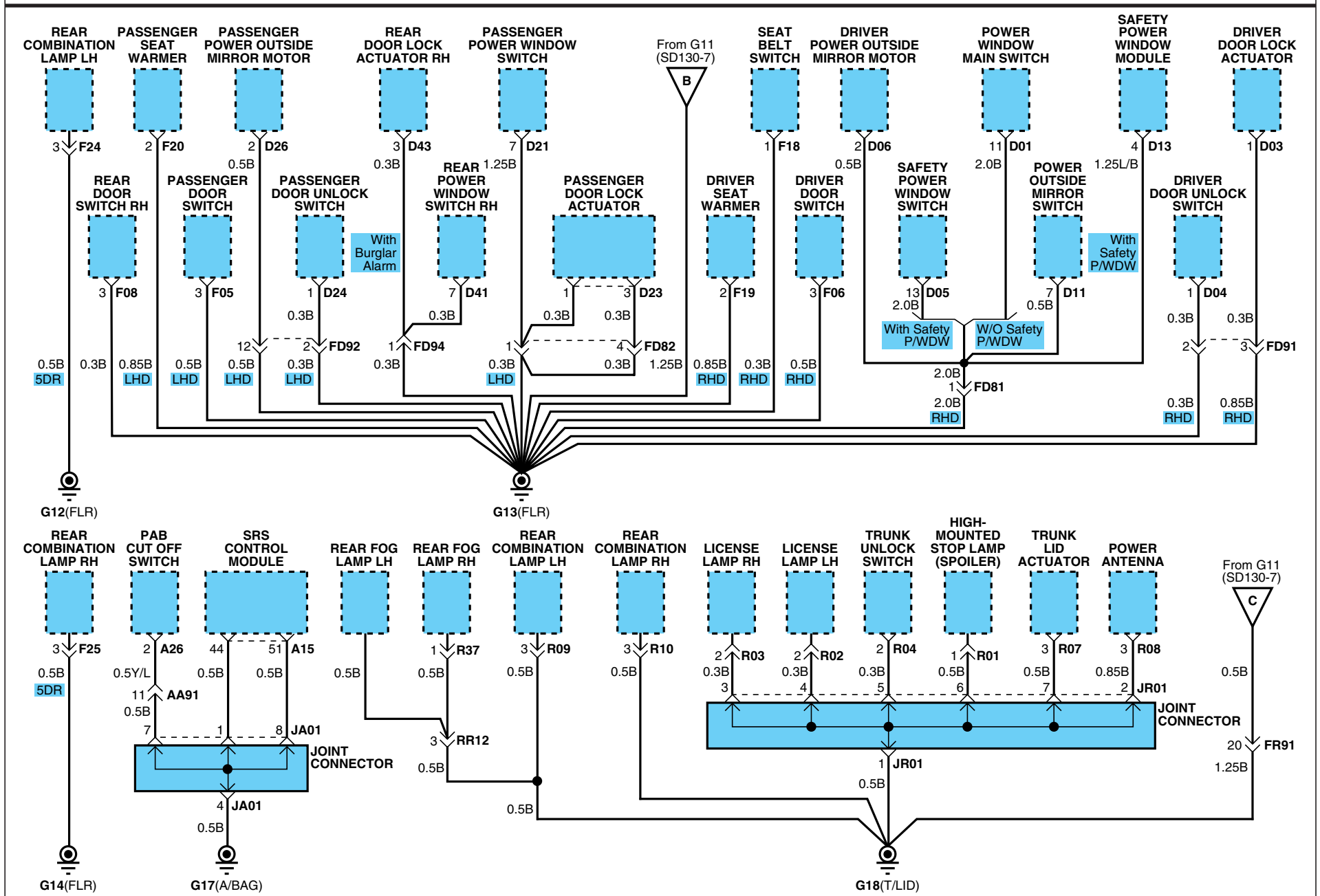



DATA LINK DETAILS

DATA LINK DETAILS (2)

SD200-2

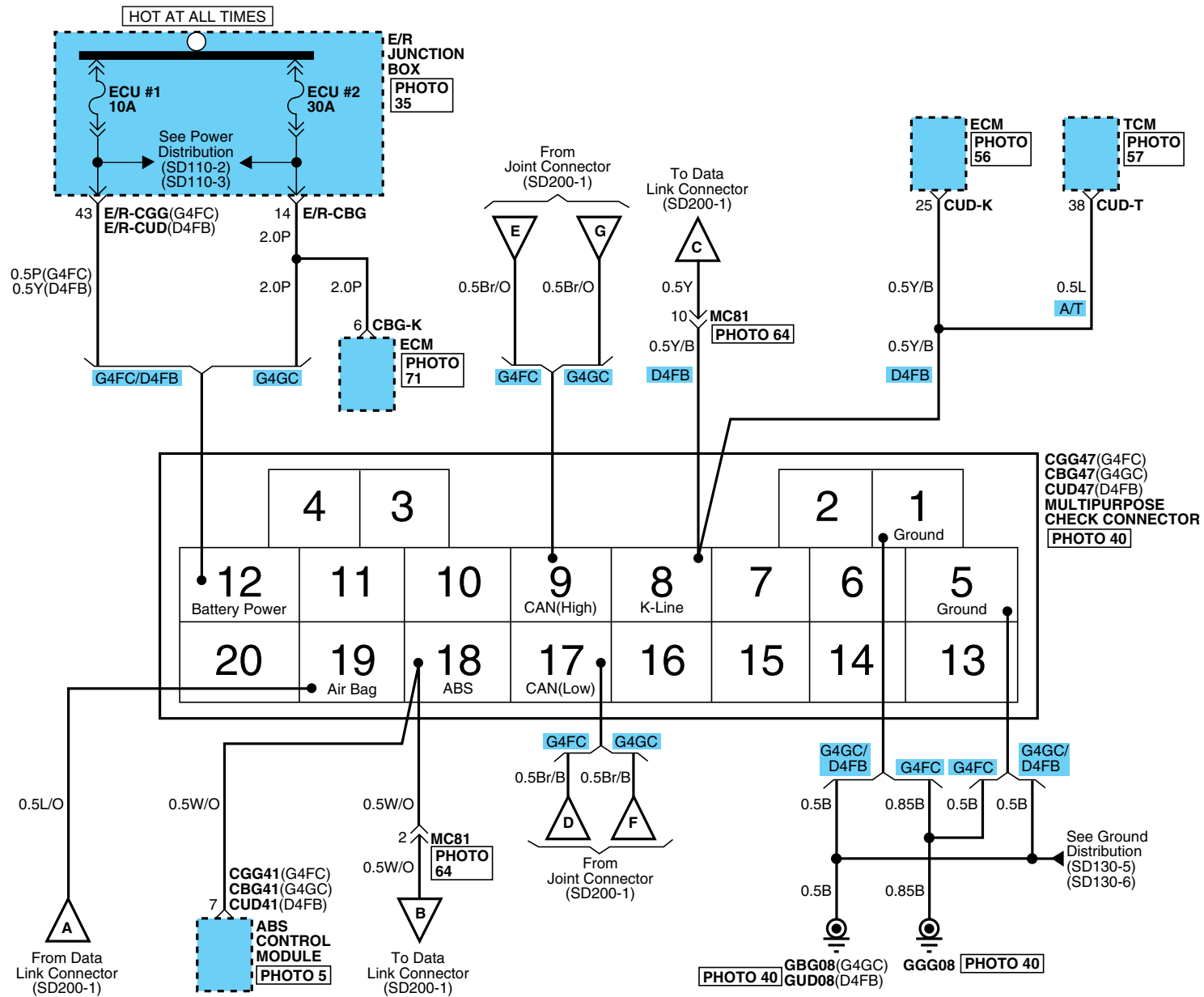

DATA LINK DETAILS

DATA LINK DETAILS (3)

SD200-3

A15

*	*	*	*	*	*	*	*	*	*	*	*	*	*	*	*	*	*	*	*	*	*	*	*	*
26	27	28	29	30	31	32	33	34	35	36	37	38	39	40	41	42	43	44	*	*	*	*	*	*
51	*	*	54	*	*	*	*	*	*	61	62	63	64	*	*	*	68	*	*	71	*	*	*	75

SIEABG\_75F\_ABG

CGGA-A

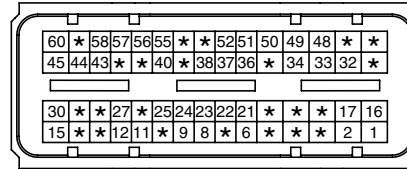

AMP\_ECU\_60F\_B

BLANK

CGGM-K

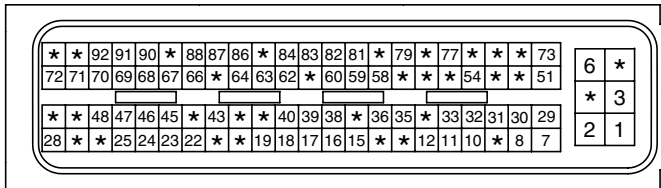

AMP\_ECU\_94F\_B

CBG-K

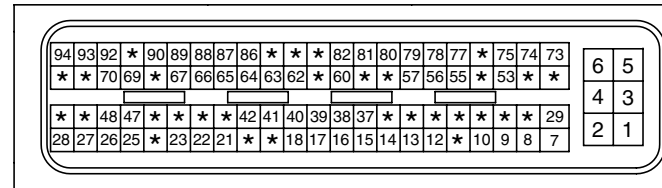

AMP\_ECU\_94F\_B

CUD-K

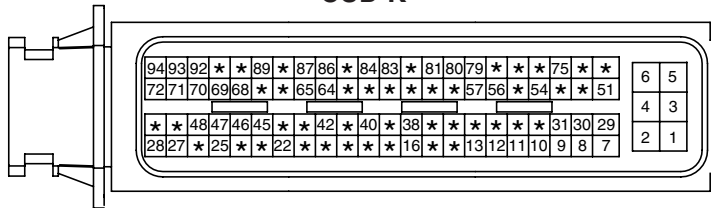

AMP\_ECU\_94F\_B

CUD-T

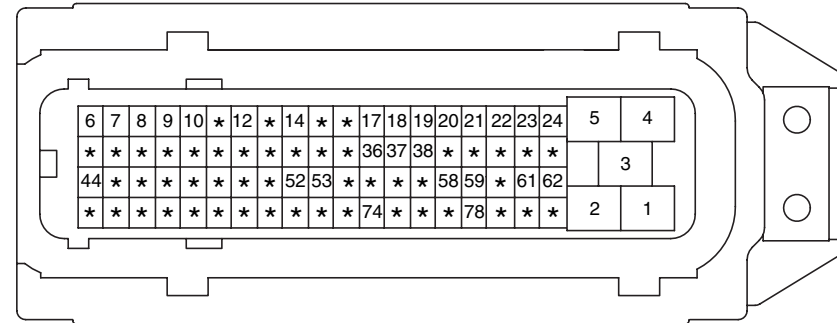

KET\_ECU\_81F\_B

CGG41

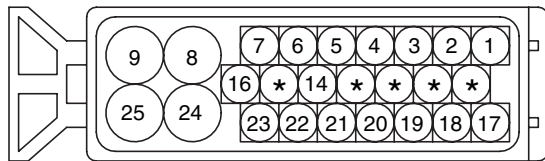

AMP\_ABSWP\_25F\_B\_GER

CGG47

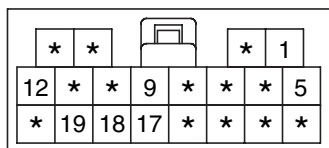

KET\_070\_20F\_B

CGG64

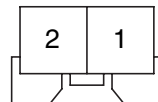

AMP\_090\_CAN\_02F

CBG41

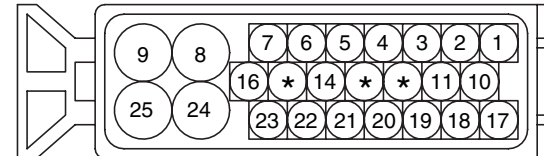

AMP\_ABSWP\_25F\_B

DATA LINK DETAILS

DATA LINK DETAILS (4)

SD200-4

CBG47

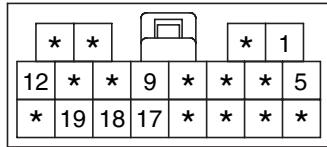

KET\_070\_20F\_B

CBG64

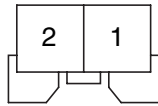

AMP\_090\_CAN\_02F

CUD41

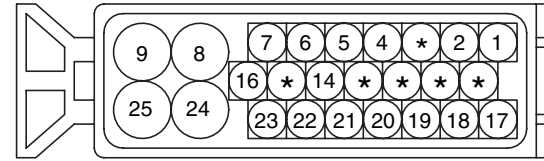

AMP\_ABSWP\_25F\_B\_GER

CUD47

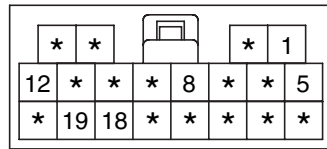

KET\_070\_20F\_B

CUD64

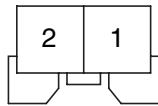

AMP\_090\_CAN\_02F

M05-1

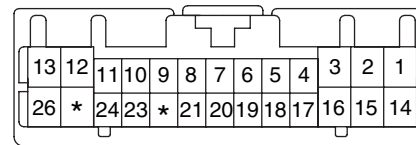

KET\_PCB\_26F

M10

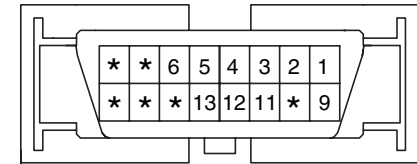

MLX\_OBDII\_16F\_B\_SIN

M25

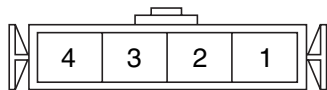

KET

BLANK

BLANK

BLANK

COOLING SYSTEM

E444A7C3

COOLING SYSTEM (1)

SD253-1

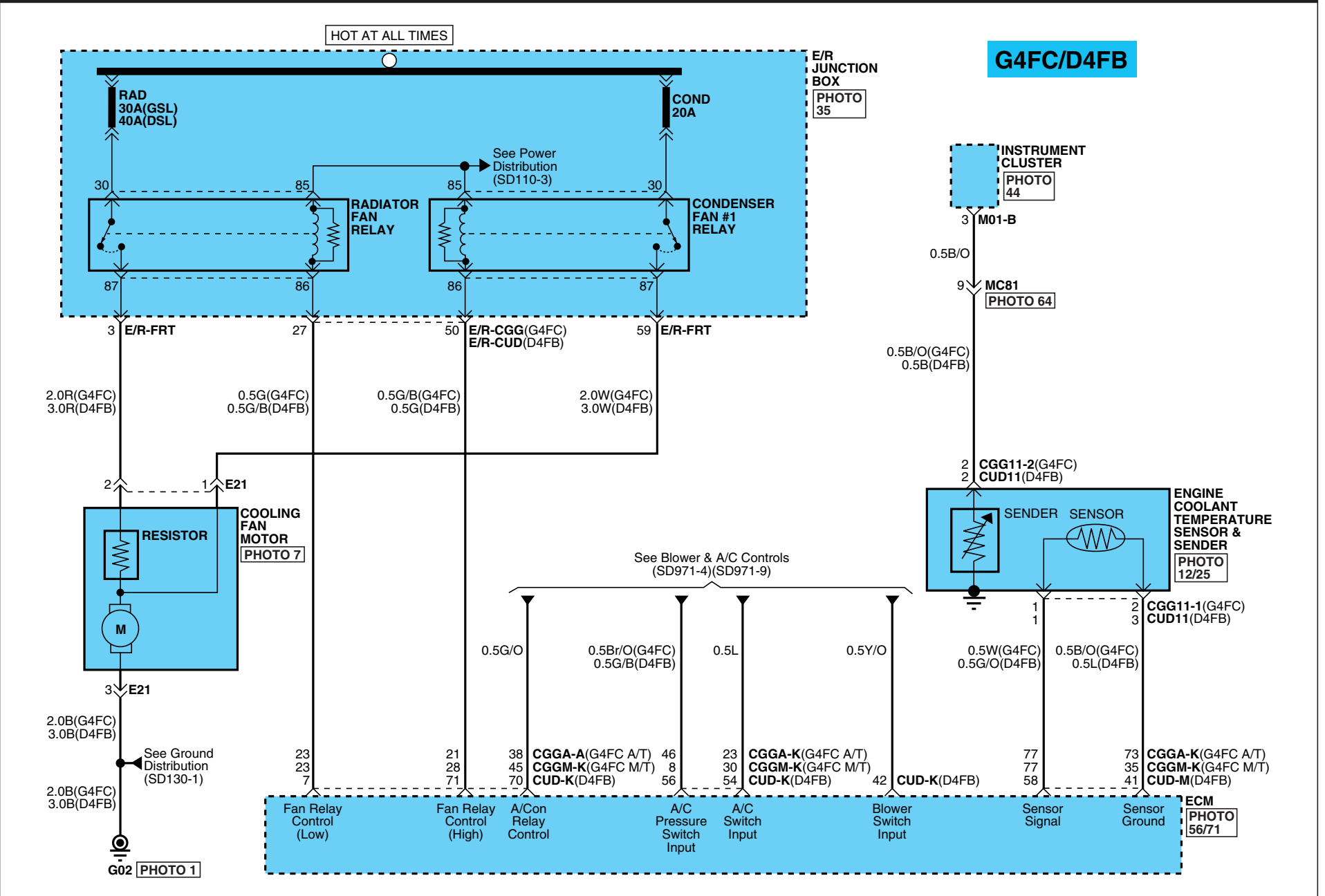



COOLING SYSTEM

COOLING SYSTEM (2)

SD253-2

G4GC

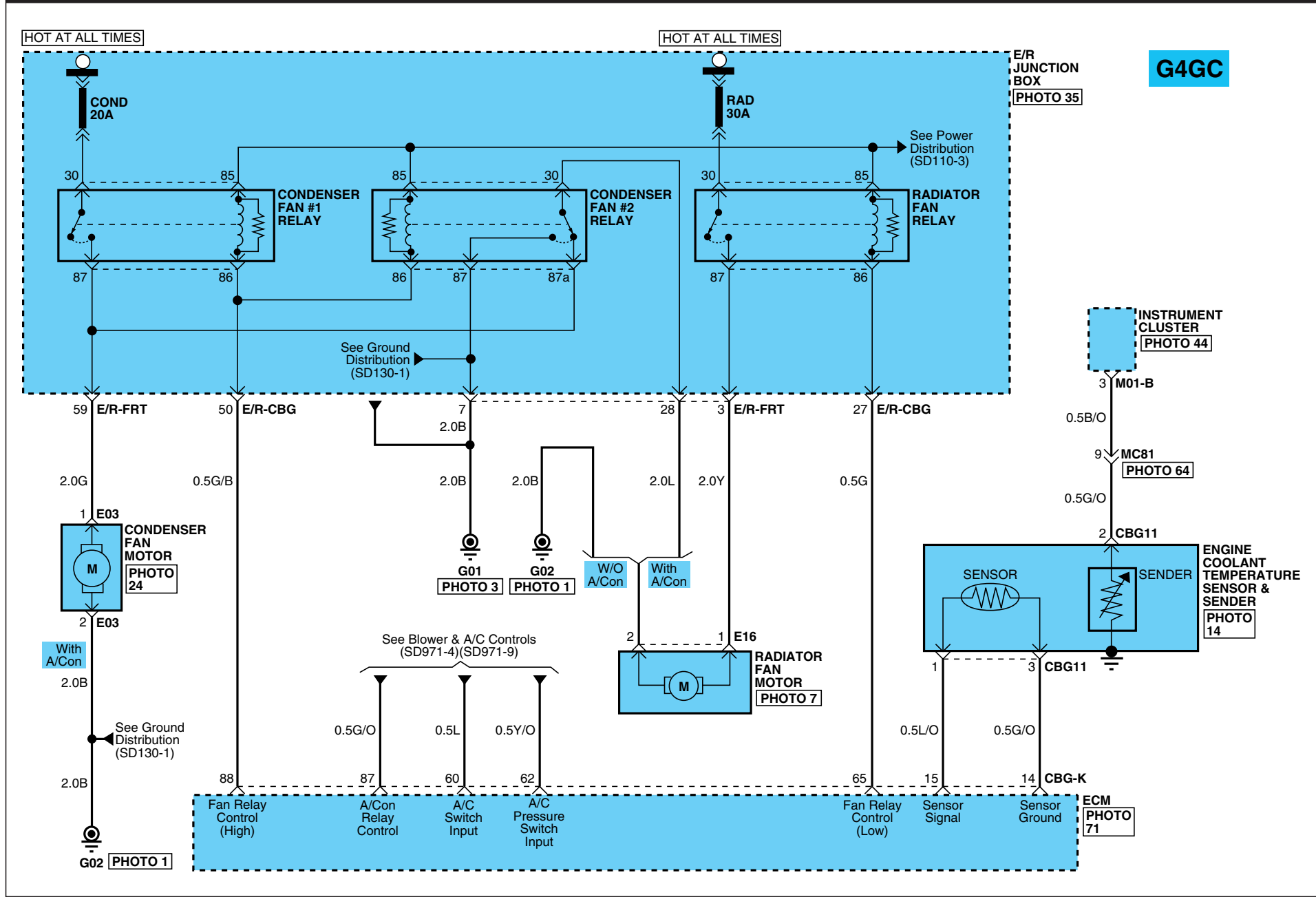

COOLING SYSTEM

COOLING SYSTEM (3)

SD253-3

CGGA-A

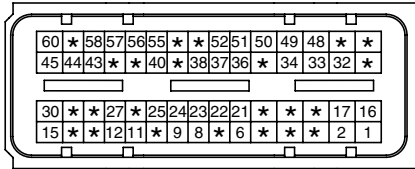

AMP\_ECU\_60F\_B

CGGA-K

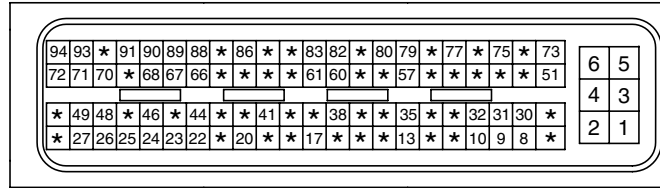

AMP\_ECU\_94F\_B

BLANK

CGGM-K

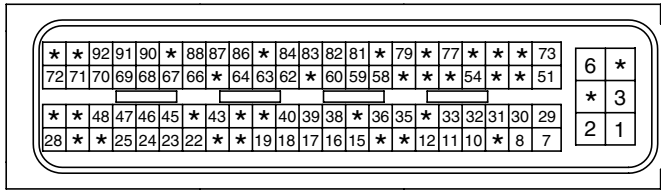

AMP\_ECU\_94F\_B

CBG-K

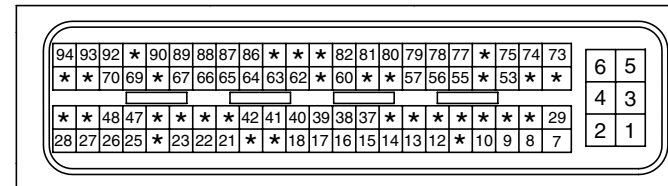

AMP\_ECU\_94F\_B

CUD-K

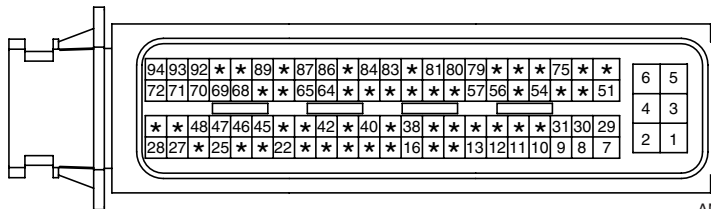

AMP\_ECU\_94F\_B

CUD-M

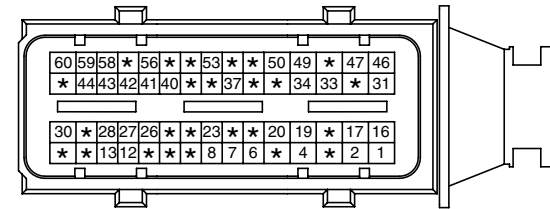

AMP\_ECU\_60F\_B

CGG11-1

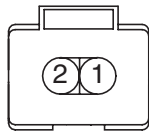

AMP\_090WP\_02F

CGG11-2

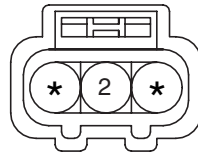

KUM\_WTS\_03F\_B

CBG11

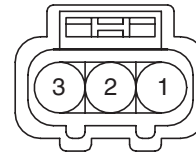

KUM\_62Z\_03F\_B

CUD11

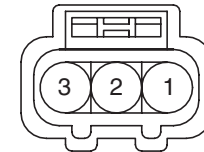

KUM\_62Z\_03F\_B

E03

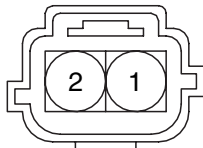

KUM\_WWP\_2F\_B

E16

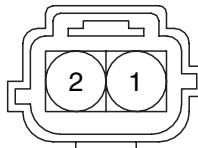

KUM\_WWP\_02F\_B

E21

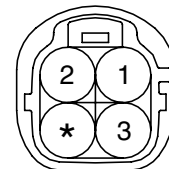

KET\_187IWP\_04F\_B

M01-B

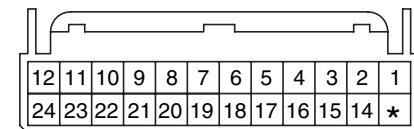

AMP\_025\_I/O\_24F

**COOLING SYSTEM**

**COOLING SYSTEM (4)**

**SD253-4**

**MEMO**

MFI CONTROL SYSTEM E9DF1F6E

MFI CONTROL SYSTEM (G4FC M/T) (1)

SD313-1

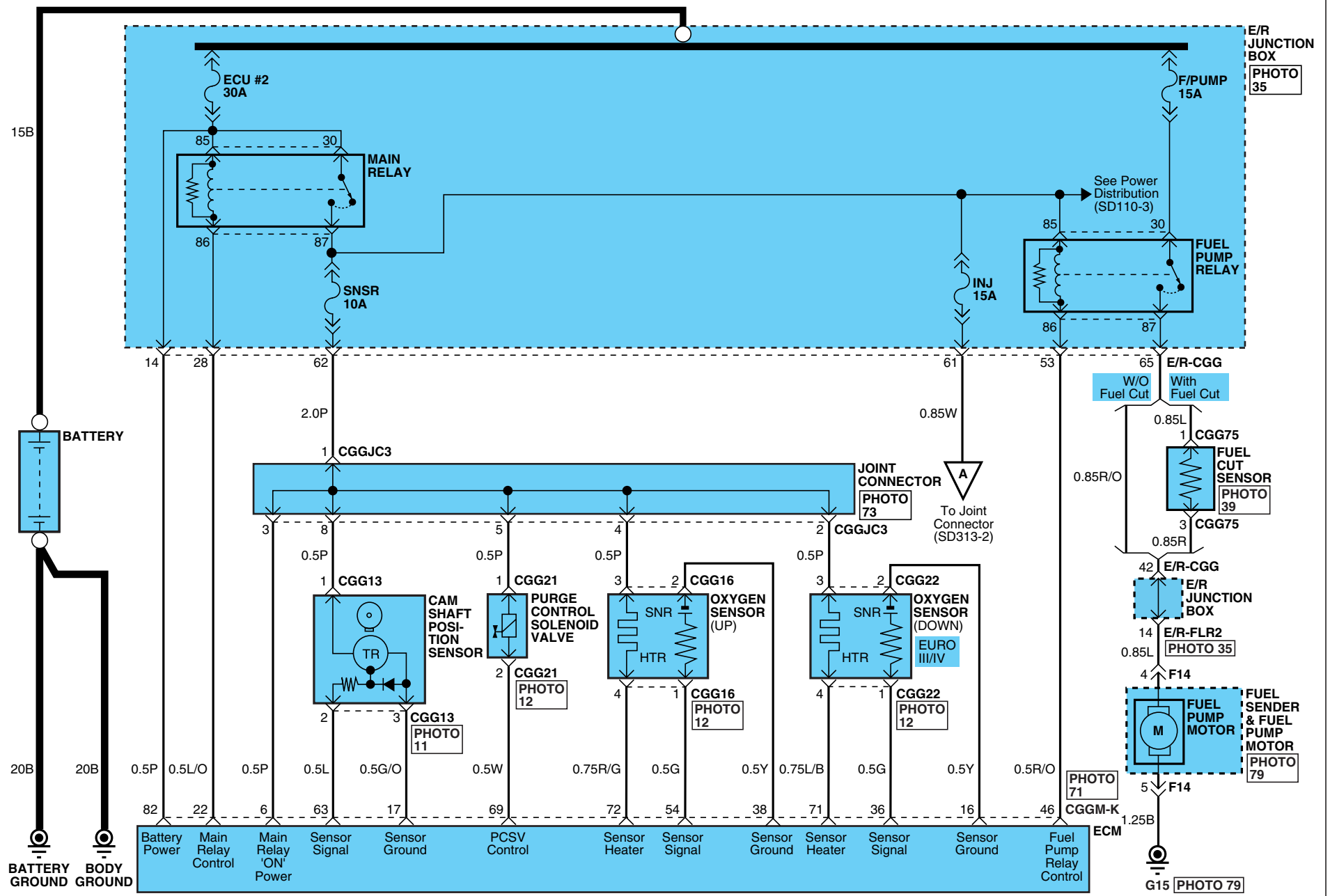

# MFI CONTROL SYSTEM

## MFI CONTROL SYSTEM (G4FC M/T) (2)

SD313-2

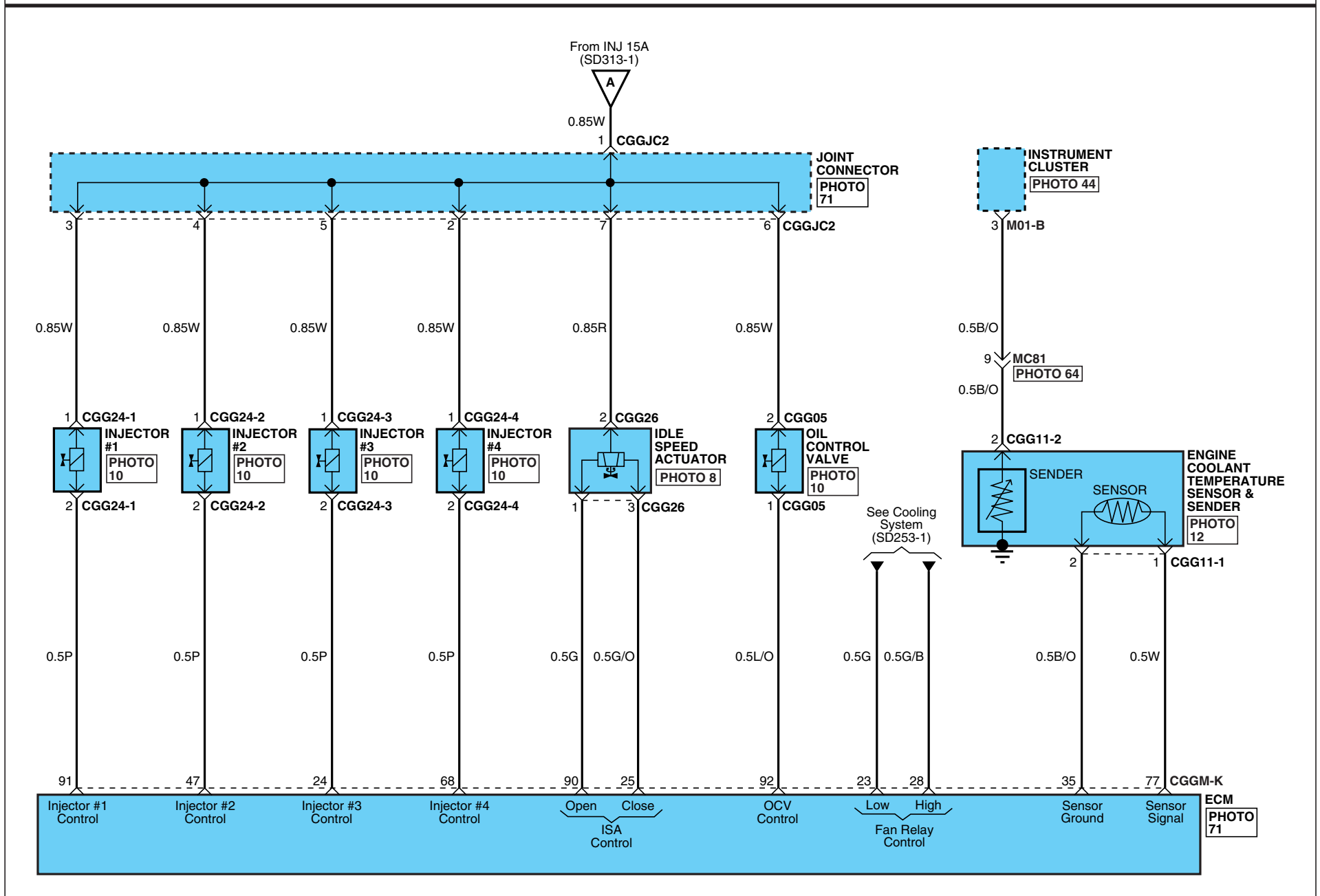

MFI CONTROL SYSTEM

MFI CONTROL SYSTEM (G4FC M/T) (3)

SD313-3

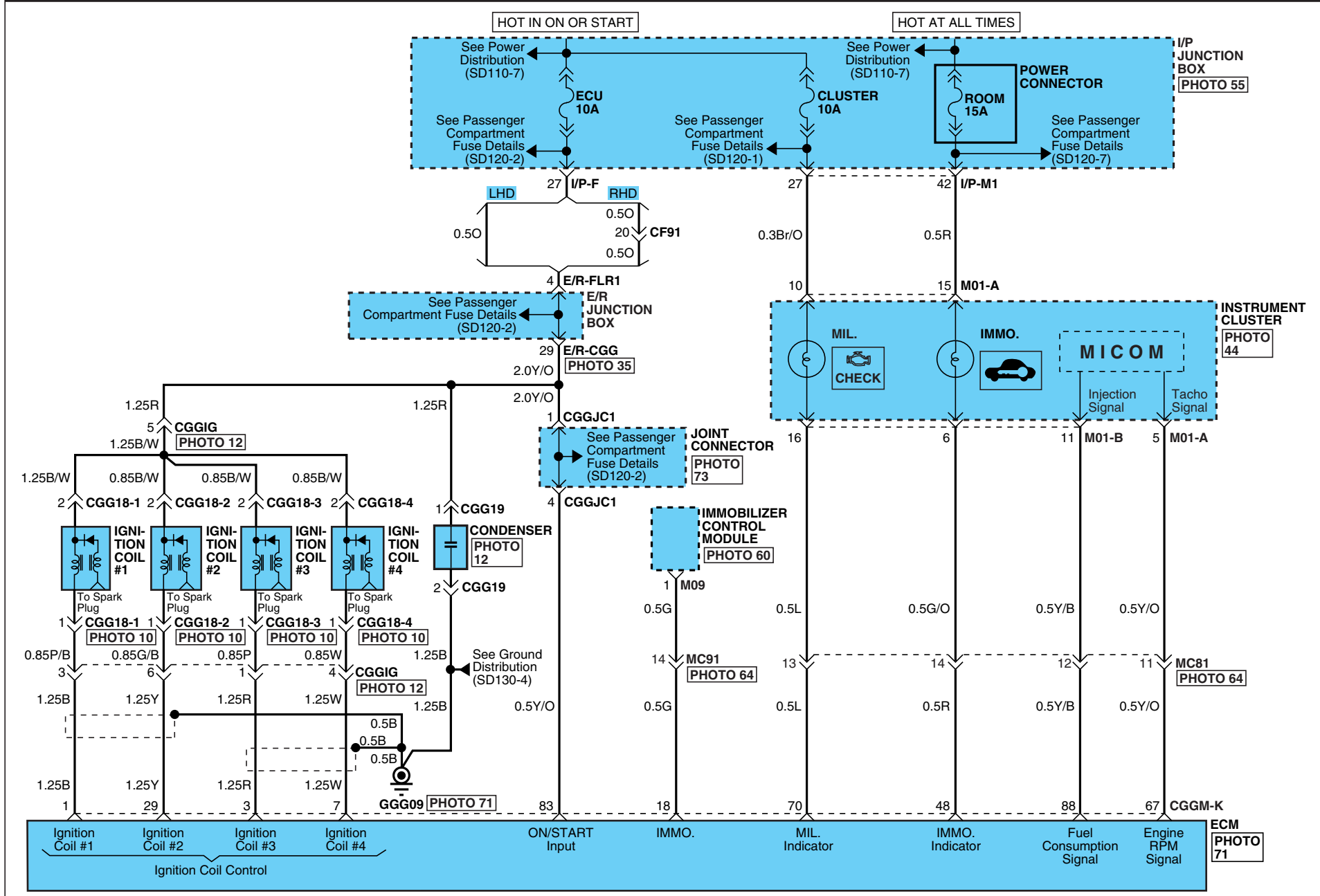

MFI CONTROL SYSTEM

MFI CONTROL SYSTEM (G4FC M/T) (4)

SD313-4

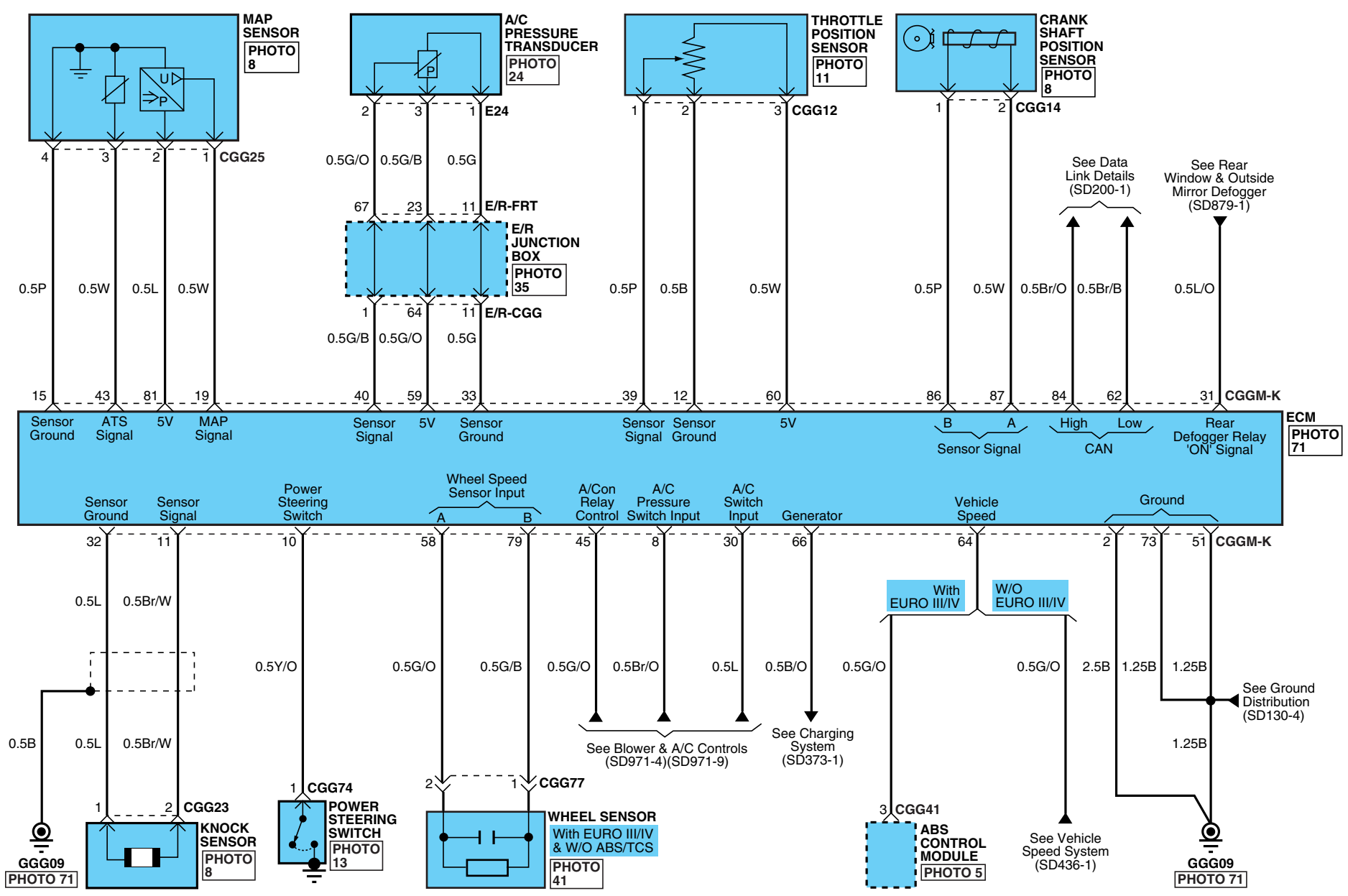

MFI CONTROL SYSTEM

MFI CONTROL SYSTEM (G4FC M/T) (5)

SD313-5

CGGM-K

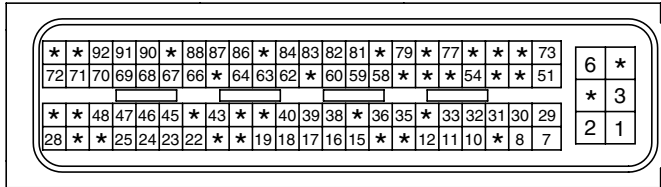

AMP\_ECU\_94F\_B

CGG05



KET\_090WP\_02F\_B

CGG11-1

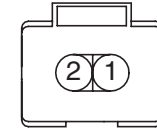

AMP\_090WP\_02F

CGG11-2

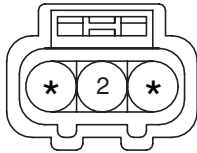

KUM\_WTS\_03F\_B

CGG12

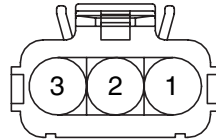

AMP\_JPT\_03F\_B\_BOSCH

CGG13

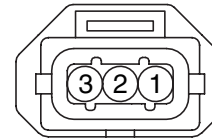

AMP\_JPT\_03F\_CODEIII

CGG14

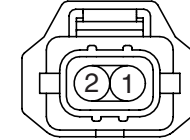

AMP\_JPT\_02F\_CODEII

CGG16

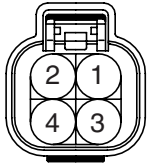

KUM\_NMWP\_04F\_B

CGG18-1

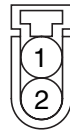

CR02F145

CGG18-2

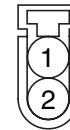

CR02F145

CGG18-3

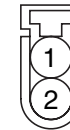

CR02F145

CGG18-4

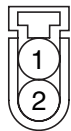

CR02F145

CGG19



MLX\_090CIGAR\_02F

CGG21

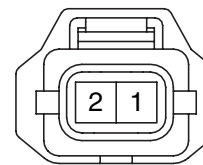

BSH\_INJ\_02F\_B

CGG22

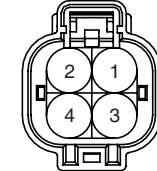

KUM\_KNMWP\_04F\_GY

CGG23

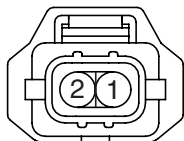

AMP\_JPT\_02F\_CODEI

CGG24-1

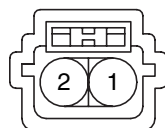

KUM\_NDWP\_02F\_B

CGG24-2

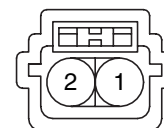

KUM\_NDWP\_02F\_B

CGG24-3

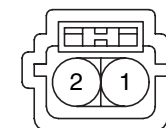



KUM\_NDWP\_02F\_B



MFI CONTROL SYSTEM

MFI CONTROL SYSTEM (G4FC M/T) (6)

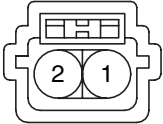
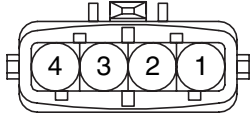
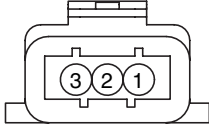
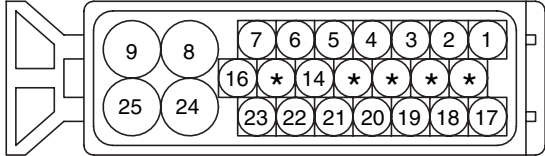
SD313-6

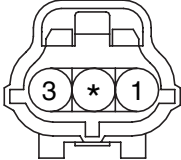
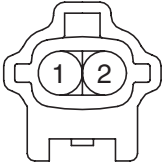
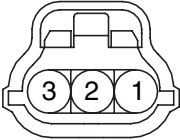
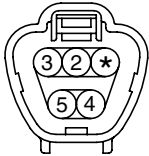
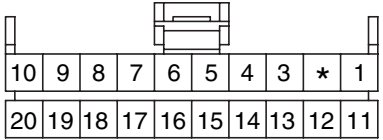
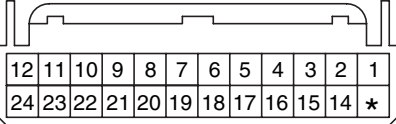
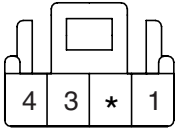
<p><b>CGG24-4</b></p>  <p>KUM_NDWP_02F_B</p>	<p><b>CGG25</b></p>  <p>AMP_JPT_04F_B_BOSCH</p>	<p><b>CGG26</b></p>  <p>BSH_ISA_03F_Gr</p>	<p><b>BLANK</b></p>
<p><b>CGG41</b></p>  <p>AMP_ABSWP_25F_B_GER</p>		<p><b>CGG74</b></p>  <p>KUM_NMWP_01F_B</p>	<p><b>CGG75</b></p>  <p>AMP_EJWP_03F_B</p>
<p><b>CGG77</b></p>  <p>KET_090IWP_02M_B</p>	<p><b>E24</b></p>  <p>KET_040WP_03F_B</p>	<p><b>F14</b></p>  <p>KET_090IWP_05F_Gr_2</p>	<p><b>M01-A</b></p>  <p>AMP_040_MK1_20F</p>
<p><b>M01-B</b></p>  <p>AMP_025_I/O_24F</p>	<p><b>M09</b></p>  <p>KET_SP_04F_W</p>	<p><b>BLANK</b></p>	<p><b>BLANK</b></p>
<p><b>BLANK</b></p>			

# MFI CONTROL SYSTEM

## MFI CONTROL SYSTEM (G4FC A/T) (1)

SD313-7

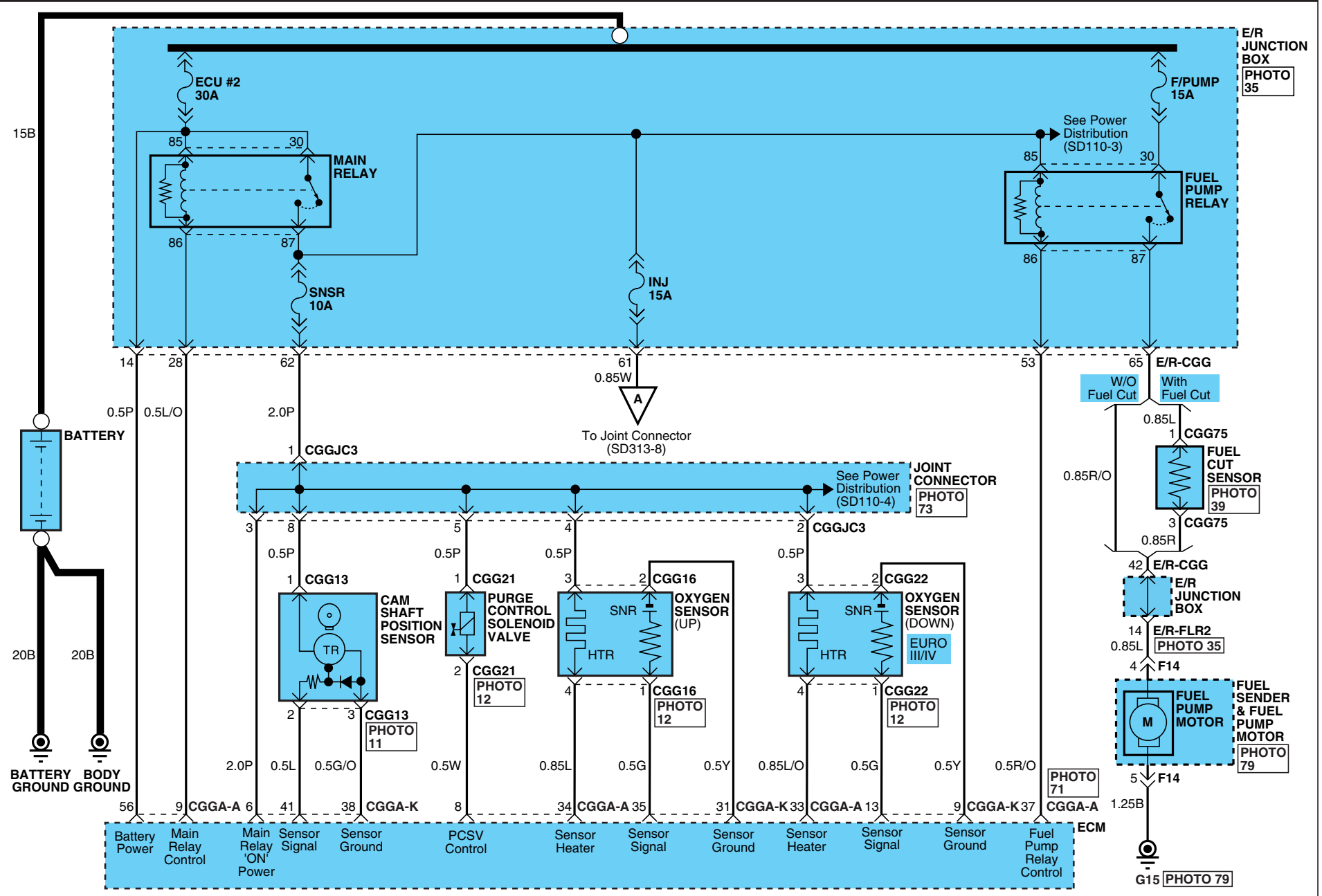

MFI CONTROL SYSTEM

MFI CONTROL SYSTEM (G4FC A/T) (2)

SD313-8

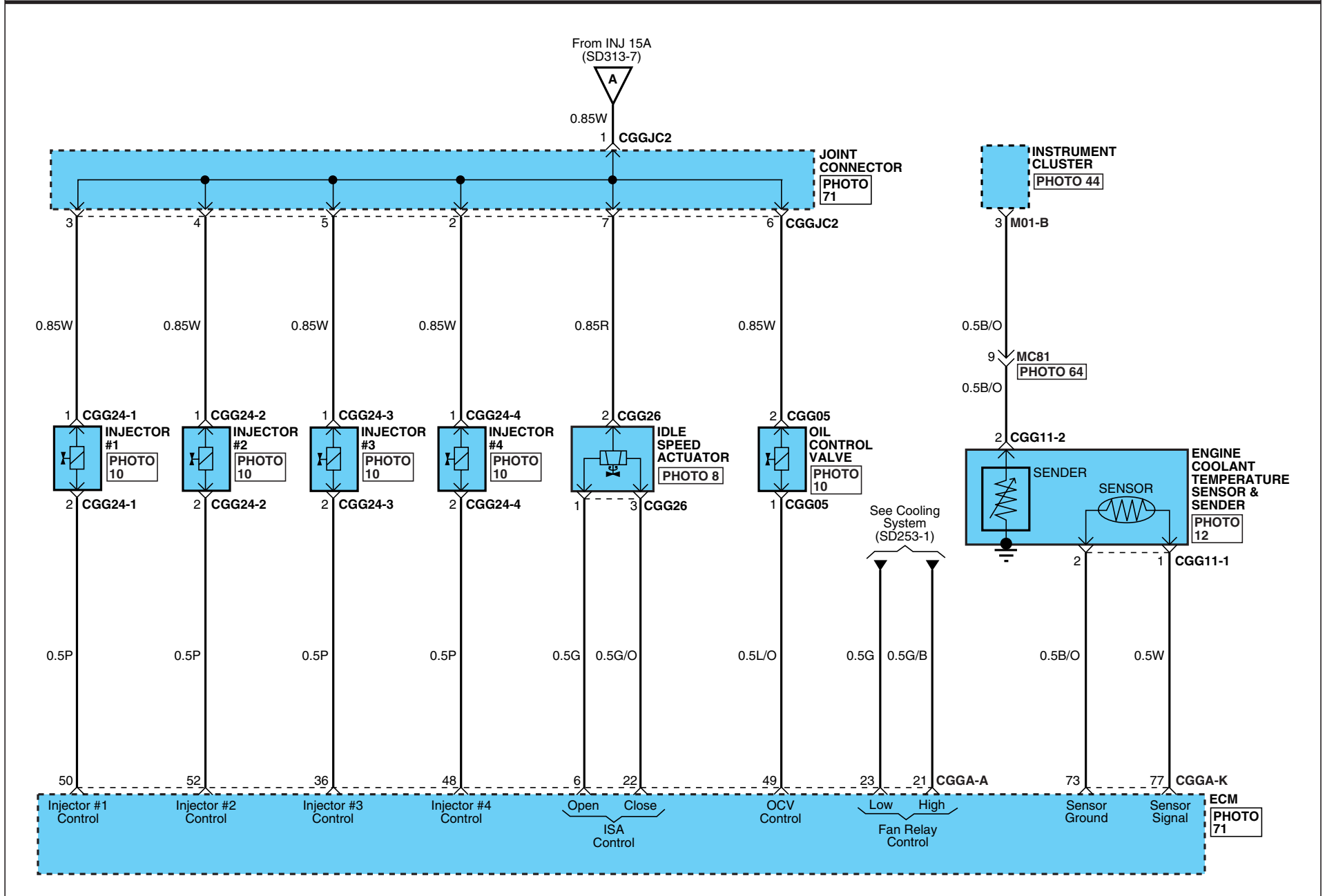

# MFI CONTROL SYSTEM

## MFI CONTROL SYSTEM (G4FC A/T) (3)

SD313-9

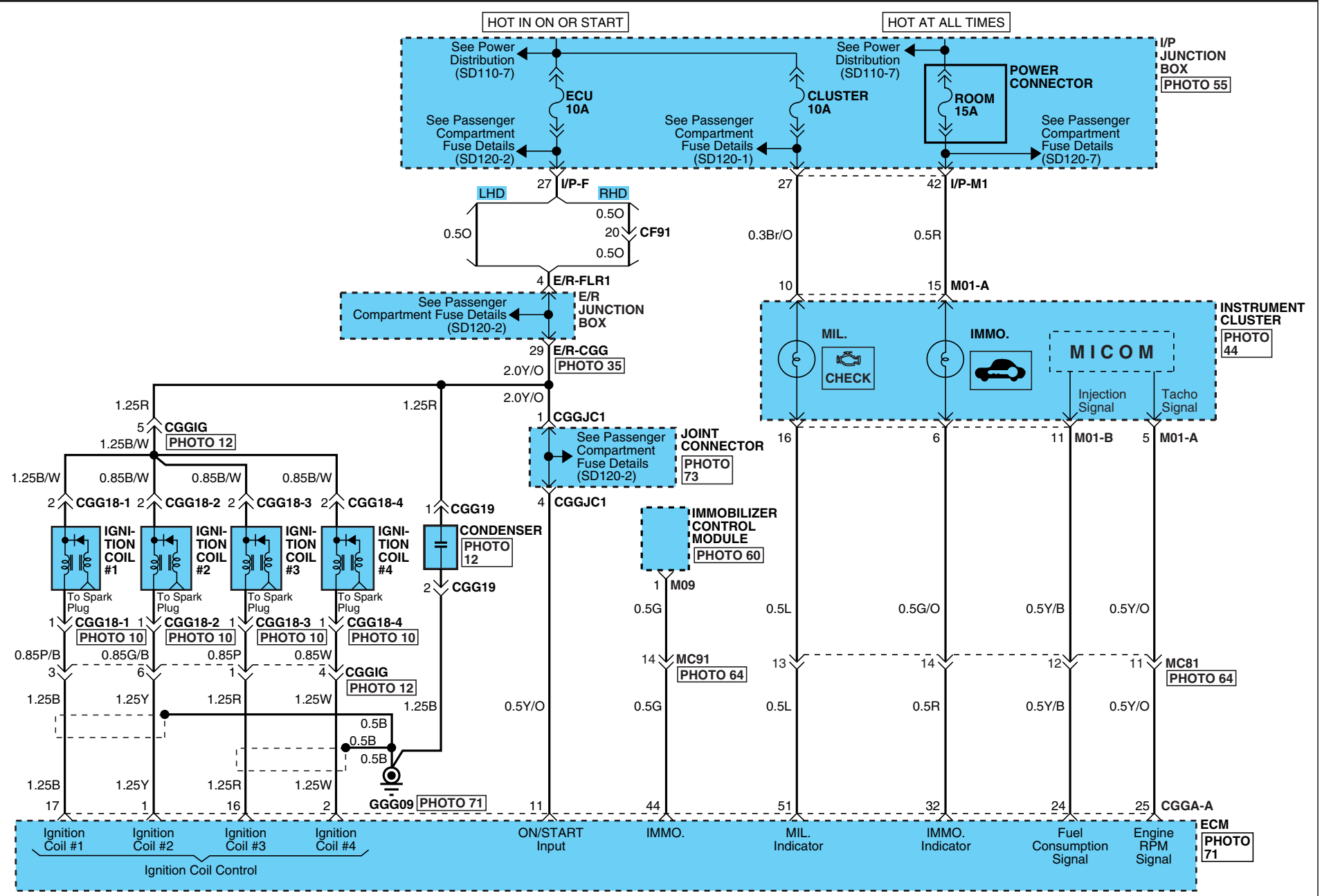

MFI CONTROL SYSTEM

MFI CONTROL SYSTEM (G4FC A/T) (4)

SD313-10

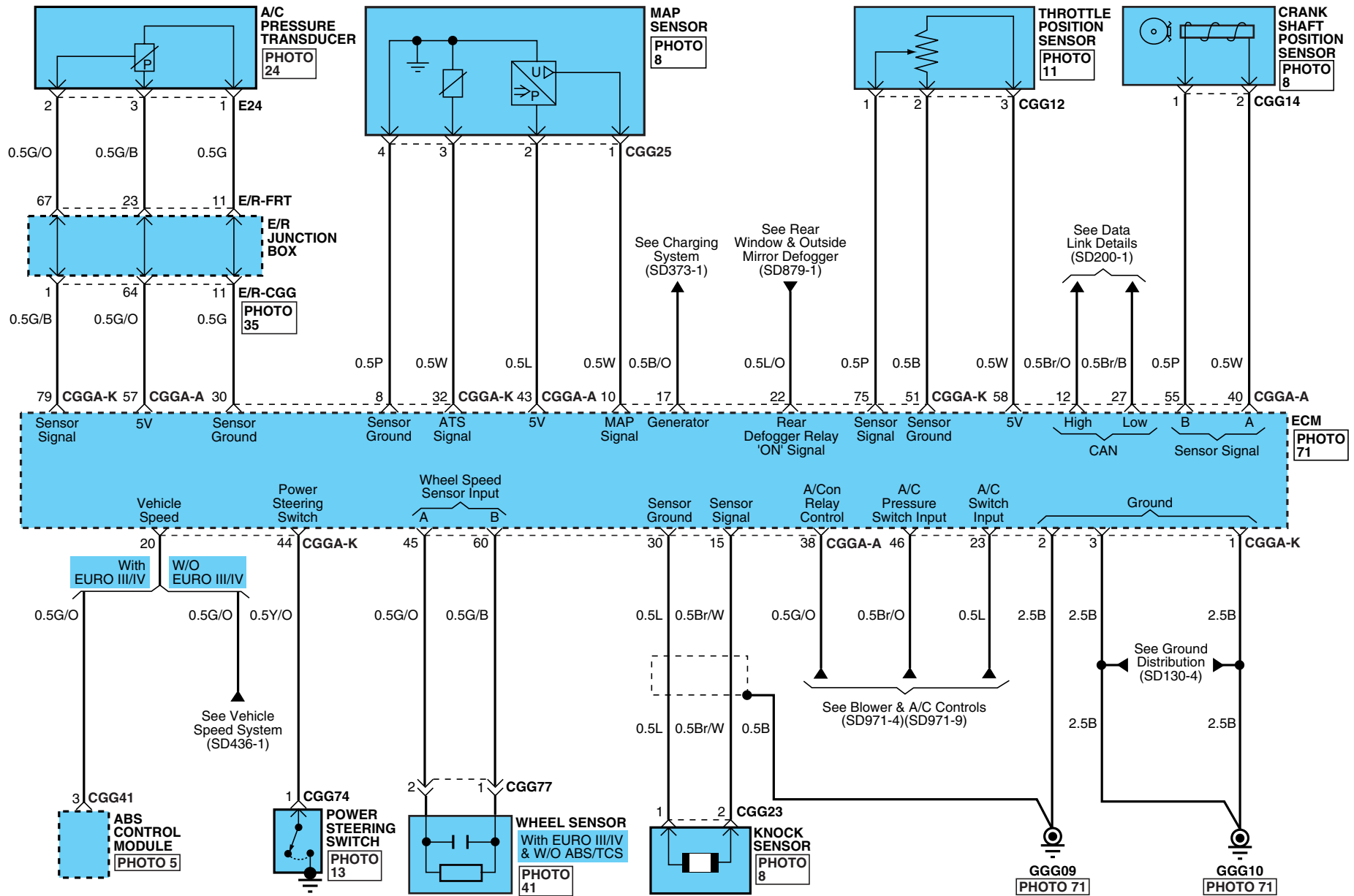

MFI CONTROL SYSTEM

MFI CONTROL SYSTEM (G4FC A/T) (5)

SD313-11

CGGA-A

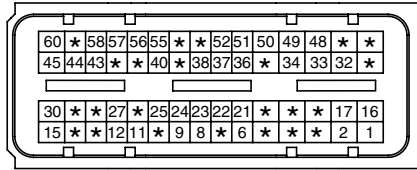

AMP\_ECU\_60F\_B

CGGA-K

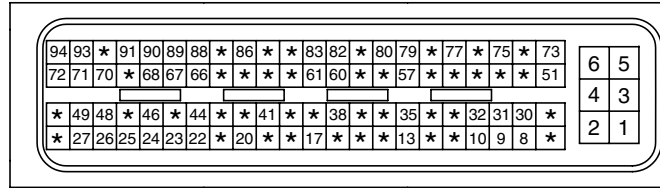

AMP\_ECU\_94F\_B

CGG05



KET\_090WP\_02F\_B

CGG11-1

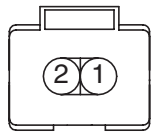

AMP\_090WP\_02F

CGG11-2

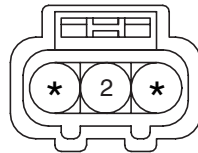

KUM\_WTS\_03F\_B

CGG12

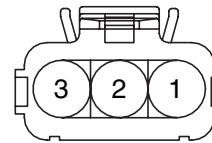

AMP\_JPT\_03F\_B\_BOSCH

CGG13

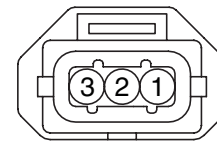

AMP\_JPT\_03F\_CODEIII

CGG14



AMP\_JPT\_02F\_CODEII

CGG16

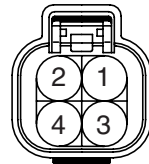

KUM\_NMWP\_04F\_B

CGG18-1

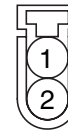

CR02F145

CGG18-2

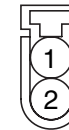

CR02F145

CGG18-3

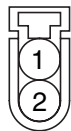

CR02F145

CGG18-4

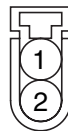

CR02F145

CGG19



MLX\_090CIGAR\_02F

CGG21

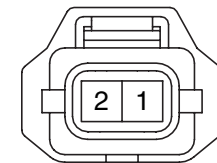

BSH\_INJ\_02F\_B

CGG22

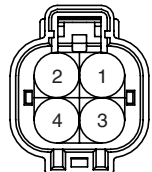

KUM\_KNMWP\_04F\_GY

CGG23

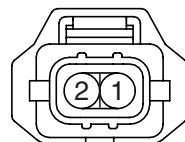

AMP\_JPT\_02F\_CODEI

CGG24-1

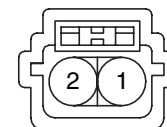

KUM\_NDWP\_02F\_B

CGG24-2

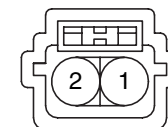





KUM\_NDWP\_02F\_B

MFI CONTROL SYSTEM

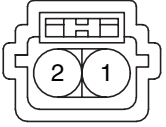
MFI CONTROL SYSTEM (G4FC A/T) (6)

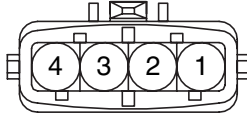
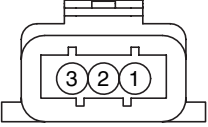
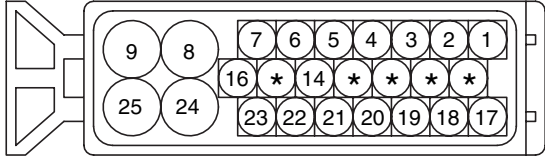
SD313-12

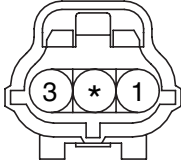
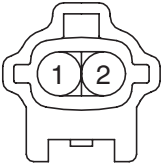
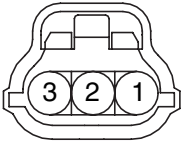
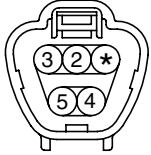
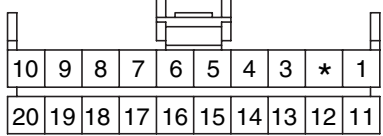
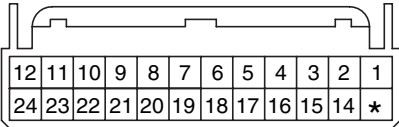
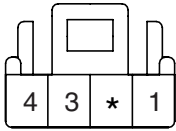
<p><b>CGG24-3</b></p>  <p>KUM_NDWP_02F_B</p>	<p><b>CGG24-4</b></p>  <p>KUM_NDWP_02F_B</p>	<p><b>CGG25</b></p>  <p>AMP_JPT_04F_B_BOSCH</p>	<p><b>CGG26</b></p>  <p>BSH_ISA_03F_Gr</p>
<p><b>CGG41</b></p>  <p>AMP_ABSWP_25F_B_GER</p>		<p><b>CGG74</b></p>  <p>KUM_NMWP_01F_B</p>	<p><b>CGG75</b></p>  <p>AMP_EJWP_03F_B</p>
<p><b>CGG77</b></p>  <p>KET_090IWP_02M_B</p>	<p><b>E24</b></p>  <p>KET_040WP_03F_B</p>	<p><b>F14</b></p>  <p>KET_090IWP_05F_Gr_2</p>	<p><b>M01-A</b></p>  <p>AMP_040_MK1_20F</p>
<p><b>M01-B</b></p>  <p>AMP_025_I/O_24F</p>	<p><b>M09</b></p>  <p>KET_SP_04F_W</p>	<p><b>BLANK</b></p>	<p><b>BLANK</b></p>
<p> </p>			

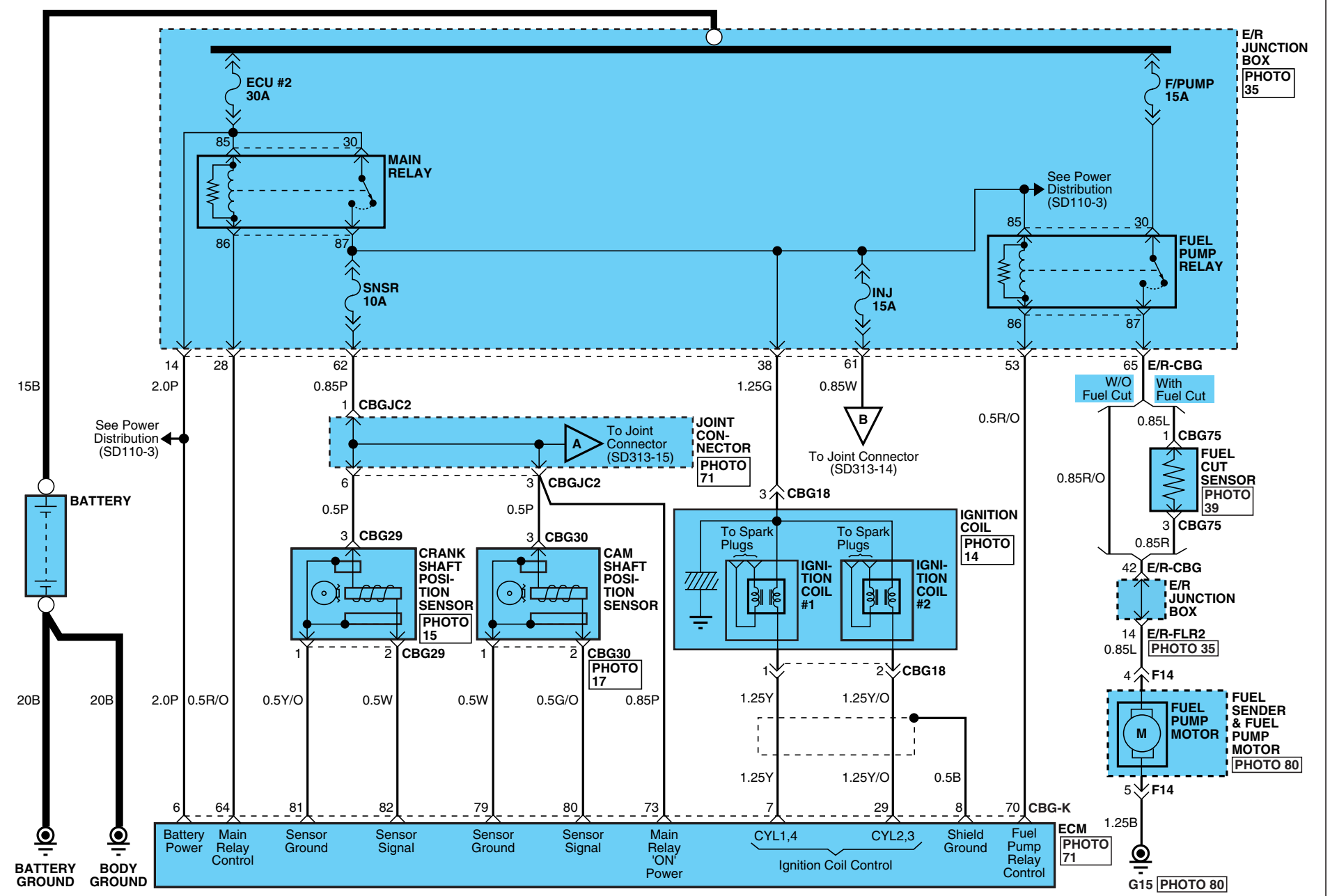



# MFI CONTROL SYSTEM

## MFI CONTROL SYSTEM (G4GC) (2)

SD313-14

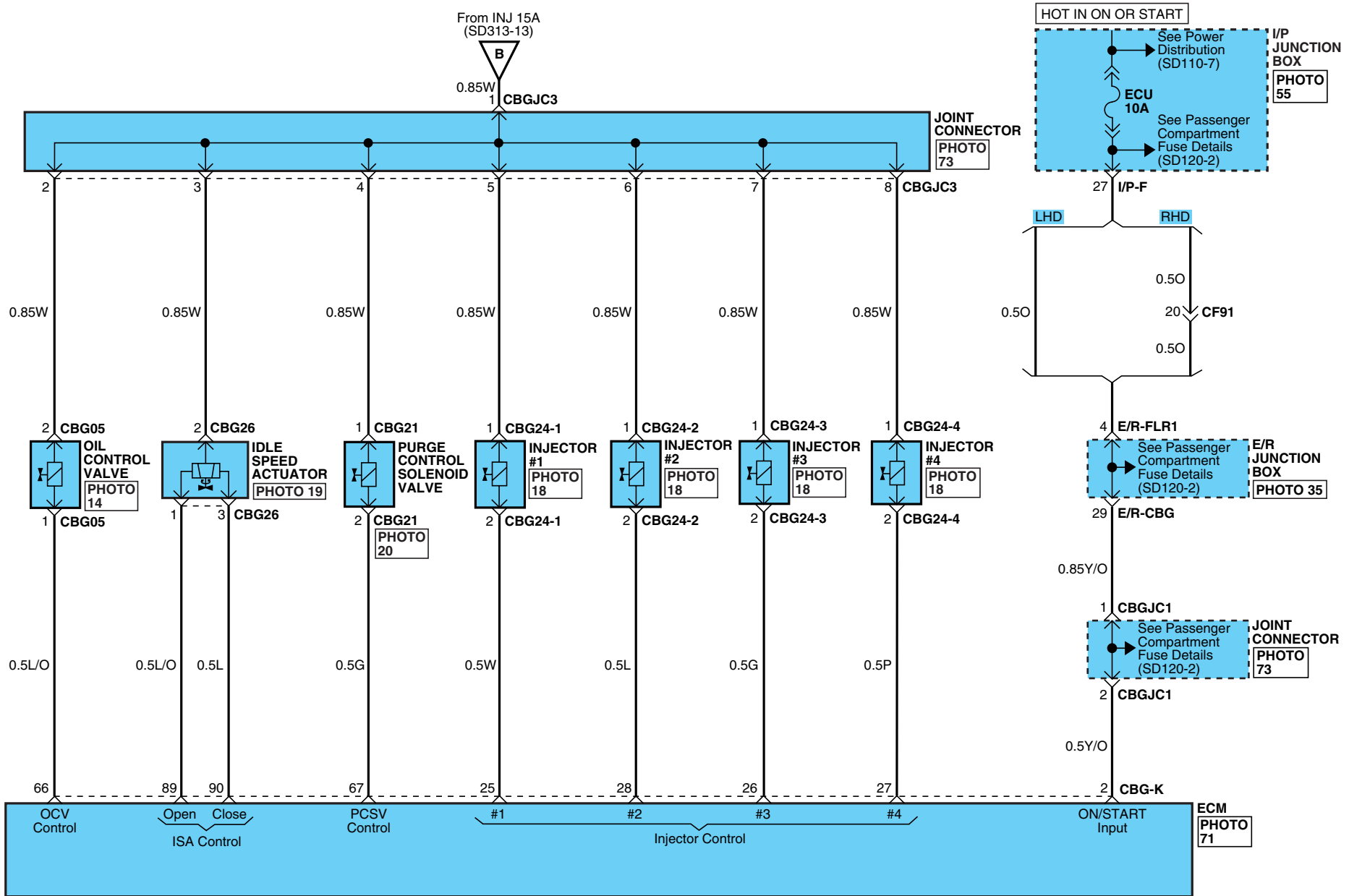

# MFI CONTROL SYSTEM

## MFI CONTROL SYSTEM (G4GC) (3)

SD313-15

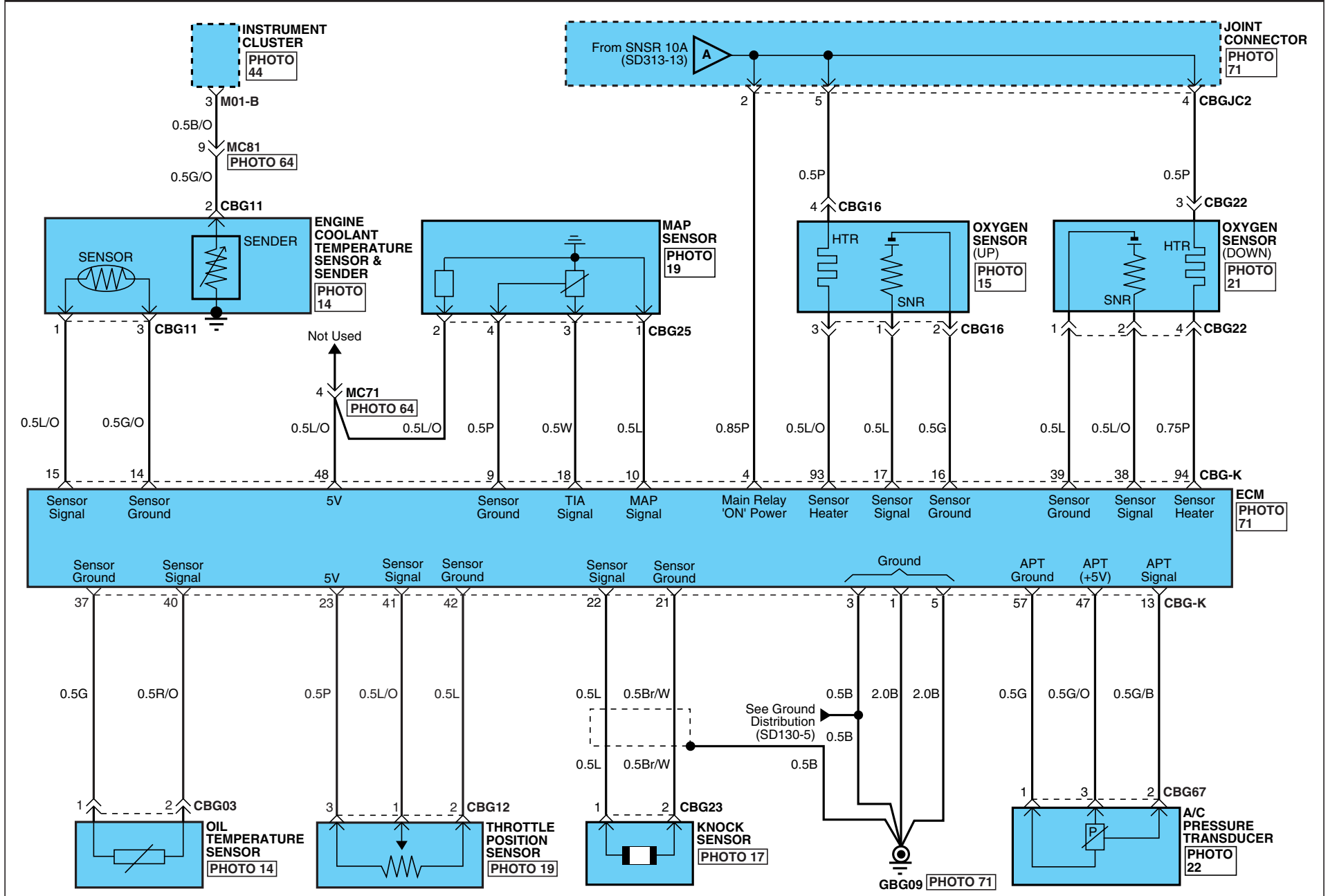

MFI CONTROL SYSTEM

MFI CONTROL SYSTEM (G4GC) (4)

SD313-16

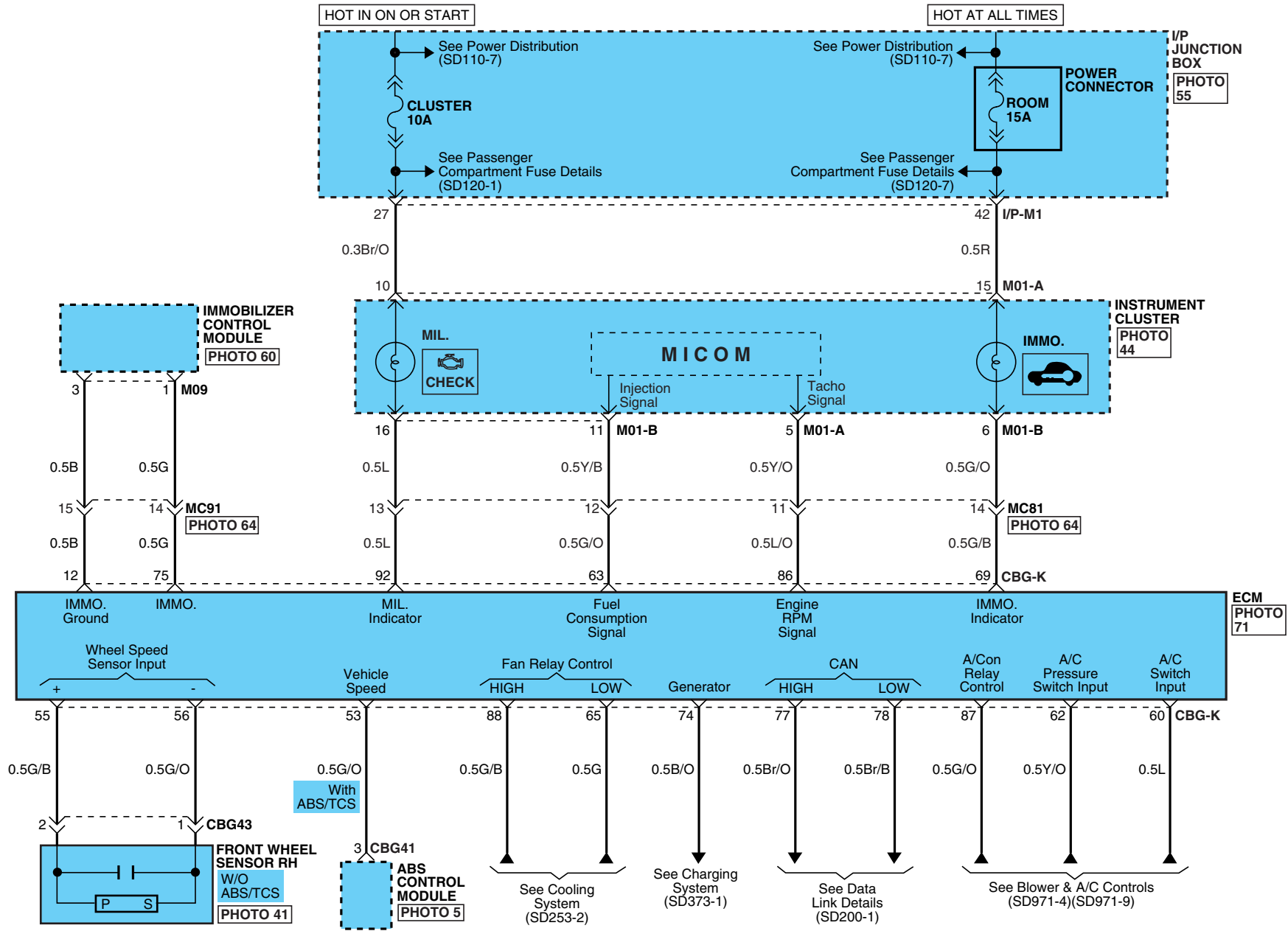

MFI CONTROL SYSTEM

MFI CONTROL SYSTEM (G4GC) (5)

SD313-17

CBG-K

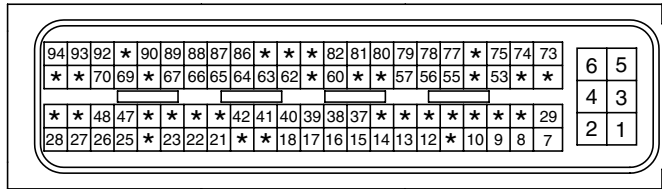

AMP\_ECU\_94F\_B

CBG03

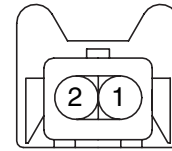

AMP\_JPT\_02F\_B

CBG05

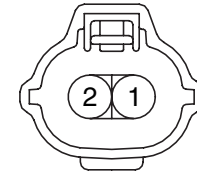

KET\_090WP\_02F\_B

CBG11

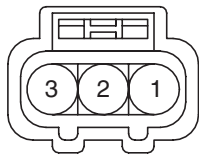

KUM\_62Z\_03F\_B

CBG12

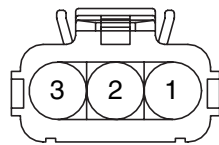

AMP\_JPT\_03F\_B\_BOSCH

CBG16



AMP\_EJWP\_04F\_B

CBG18

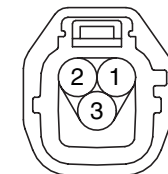

KET\_090IWP\_03F\_GY

CBG21

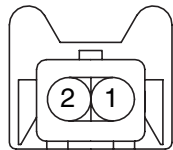

AMP\_JPT\_02F\_B

CBG22

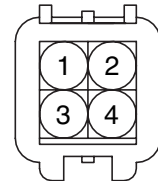

KUM\_NMWP\_04M\_B

CBG23

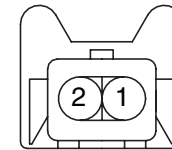

AMP\_JPT\_02F\_B

CBG24-1

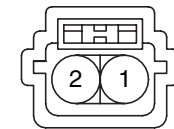

KUM\_NDWP\_02F\_B

CBG24-2

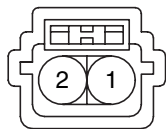

KUM\_NDWP\_02F\_B

CBG24-3

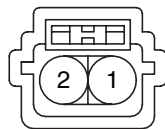

KUM\_NDWP\_02F\_B

CBG24-4

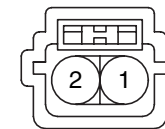

KUM\_NDWP\_02F\_B

CBG25

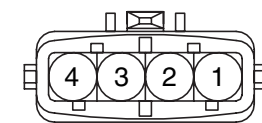

AMP\_JPT\_04F\_B

CBG26

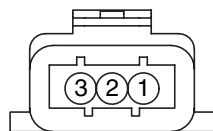

BOSCH\_ISA\_03F\_Gr

CBG29

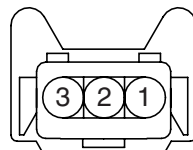

AMP\_JPT\_03F\_B

CBG30

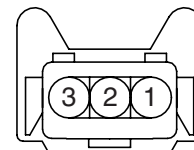

AMP\_JPT\_03F\_B

BLANK

MFI CONTROL SYSTEM

MFI CONTROL SYSTEM (G4GC) (6)

SD313-18

CBG41

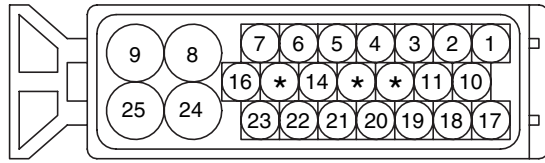

AMP\_ABSWP\_25F\_B

CBG43

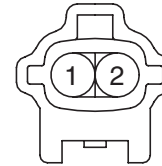

KET\_090IWP\_02M\_B

CBG67

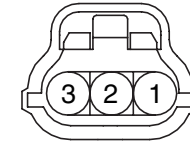

KET\_040WP\_03F\_B

CBG75

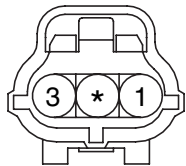

AMP\_EJWP\_03F\_B

F14

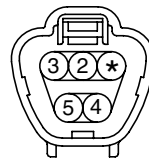

KET\_090IWP\_05F\_Gr\_2

M01-A

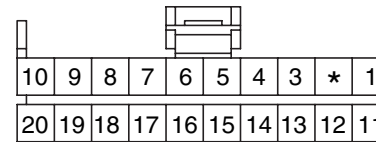

AMP\_040\_MK1\_20F

M01-B

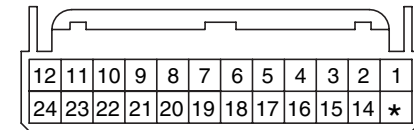

AMP\_025\_I/O\_24F

M09

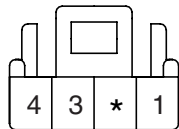

KET\_SP\_04F\_W

BLANK

BLANK

BLANK

MFI CONTROL SYSTEM ED5D57F9

MFI CONTROL SYSTEM (D4FB) (1)

SD313-19

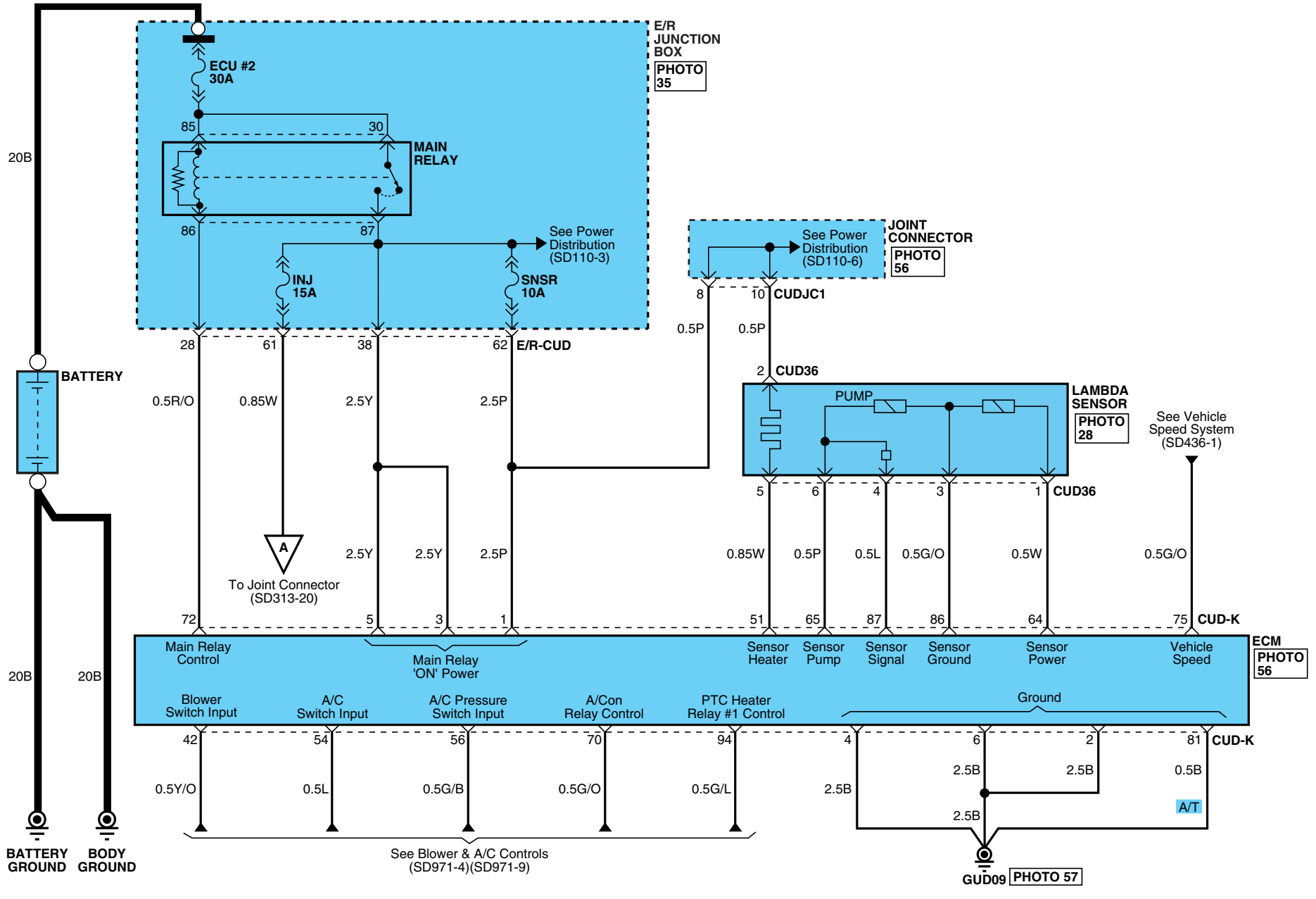

# MFI CONTROL SYSTEM

## MFI CONTROL SYSTEM (D4FB) (2)

SD313-20

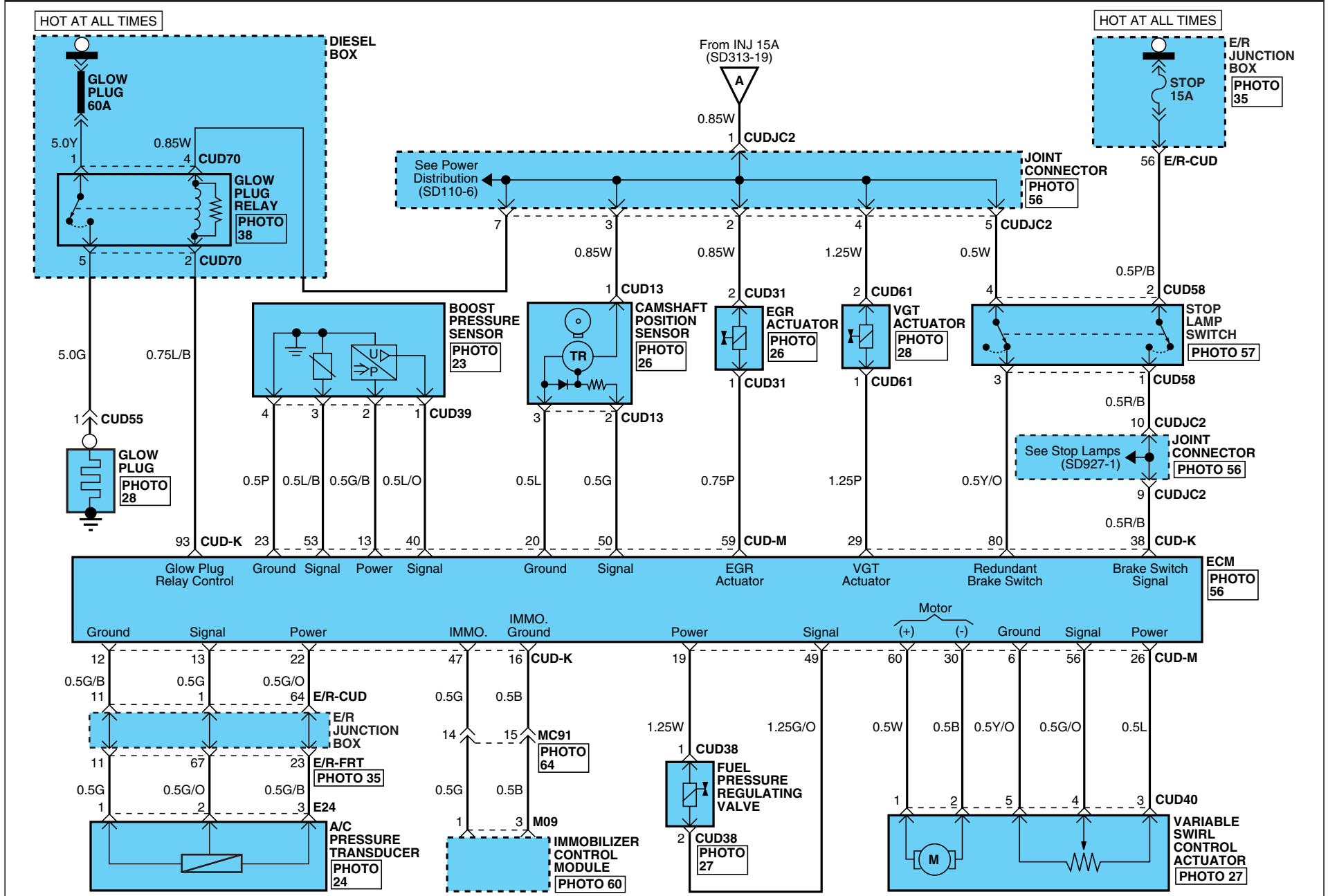

# MFI CONTROL SYSTEM

## MFI CONTROL SYSTEM (D4FB) (3)

SD313-21

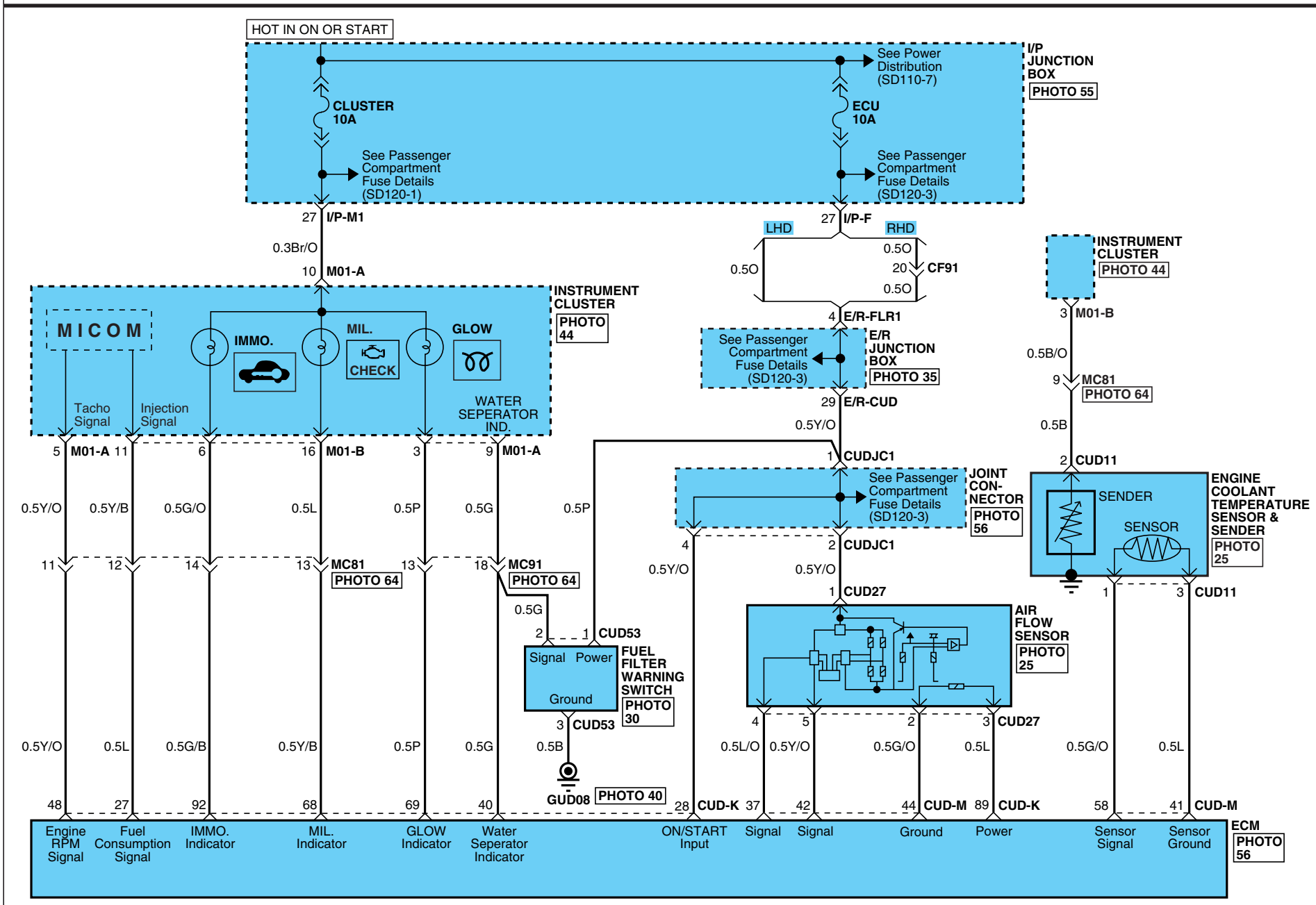



# MFI CONTROL SYSTEM

## MFI CONTROL SYSTEM (D4FB) (4)



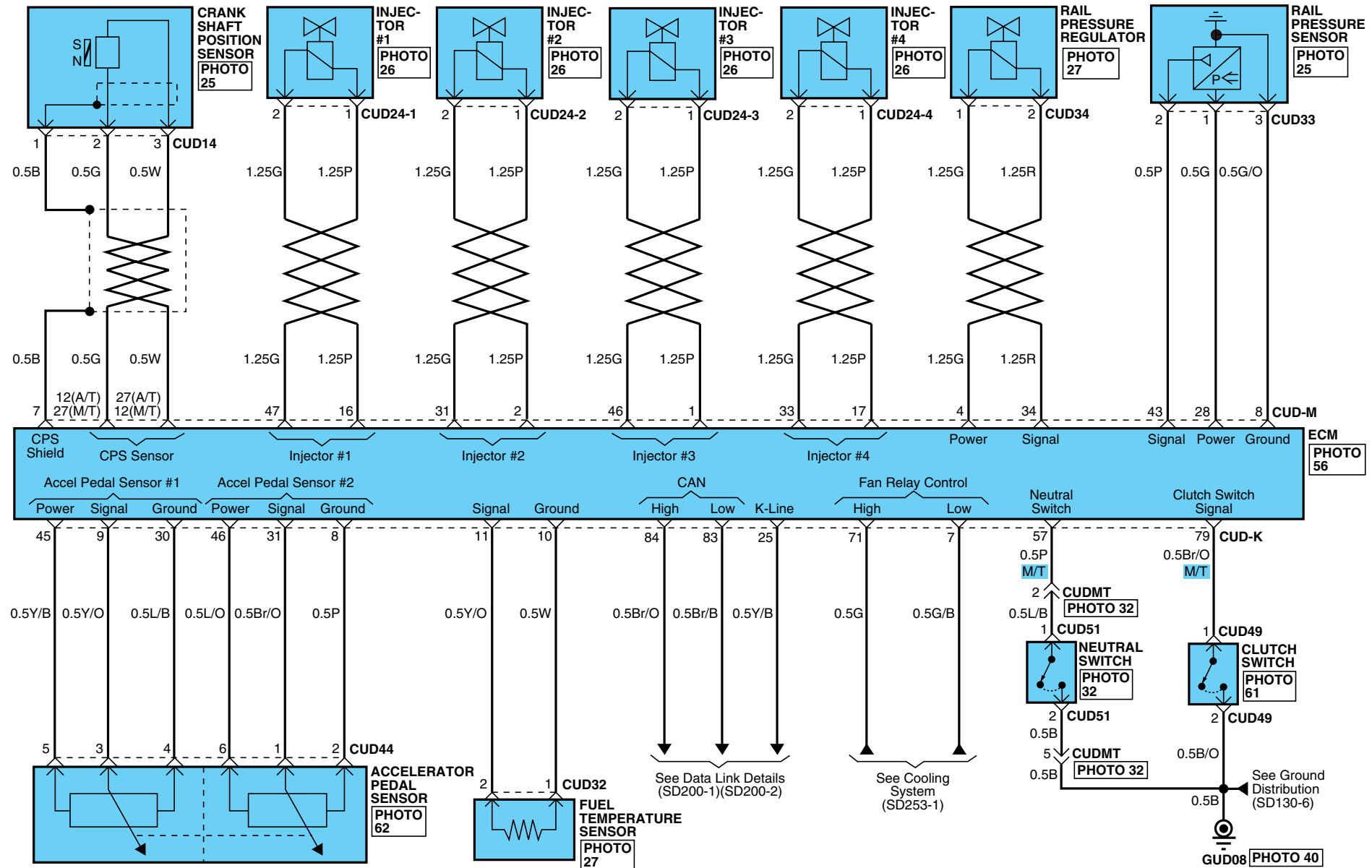

SD313-22

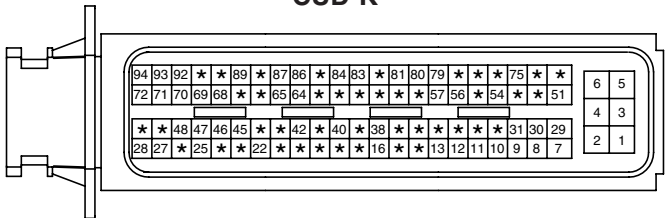
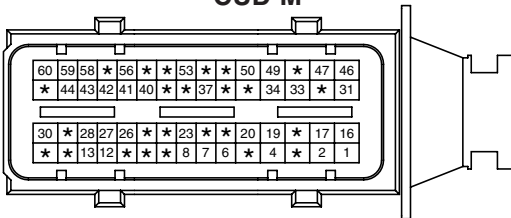
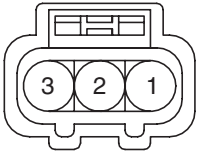
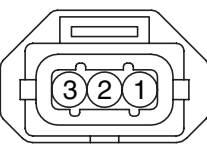
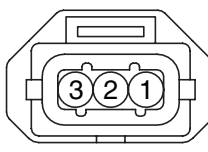

MFI CONTROL SYSTEM

MFI CONTROL SYSTEM (D4FB) (5)

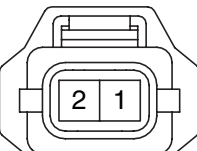
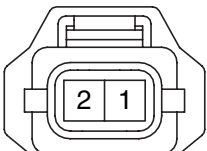

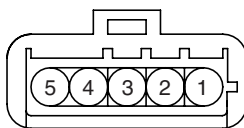
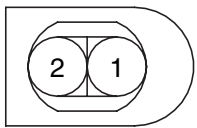
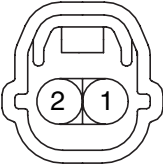
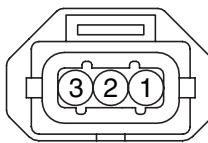
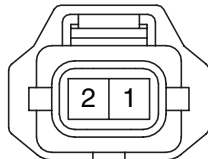
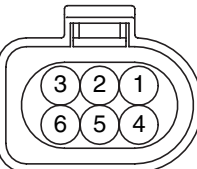
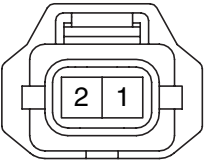
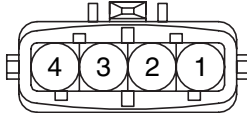
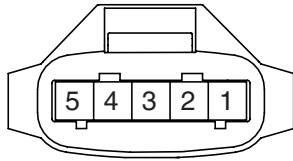
SD313-23

<p style="text-align: center;"><b>CUD-K</b></p>  <p style="text-align: right;">AMP_ECU_94F_B</p>		<p style="text-align: center;"><b>CUD-M</b></p>  <p style="text-align: right;">AMP_ECU_60F_B</p>	
<p style="text-align: center;"><b>CUD11</b></p>  <p style="text-align: right;">KUM_62Z_03F_B</p>	<p style="text-align: center;"><b>CUD13</b></p>  <p style="text-align: right;">AMP_JPT_03F_B</p>	<p style="text-align: center;"><b>CUD14</b></p>  <p style="text-align: right;">AMP_JPT_03F_B</p>	<p style="text-align: center;"><b>CUD24-1</b></p>  <p style="text-align: right;">AMP_JPT_02F_B</p>
<p style="text-align: center;"><b>CUD24-2</b></p>  <p style="text-align: right;">AMP_JPT_02F_B</p>	<p style="text-align: center;"><b>CUD24-3</b></p>  <p style="text-align: right;">AMP_JPT_02F_B</p>	<p style="text-align: center;"><b>CUD24-4</b></p>  <p style="text-align: right;">AMP_JPT_02F_B</p>	<p style="text-align: center;"><b>CUD27</b></p>  <p style="text-align: right;">HIRSCHMANN_05F</p>
<p style="text-align: center;"><b>CUD31</b></p>  <p style="text-align: right;">KST_SENSOR_02F_B</p>	<p style="text-align: center;"><b>CUD32</b></p>  <p style="text-align: right;">KET_SSD_02F_B</p>	<p style="text-align: center;"><b>CUD33</b></p>  <p style="text-align: right;">AMP_JPT_03F_B</p>	<p style="text-align: center;"><b>CUD34</b></p>  <p style="text-align: right;">BOSCH_INJ_02F_B</p>
<p style="text-align: center;"><b>CUD36</b></p>  <p style="text-align: right;">BSH_SENSOR_06F_B</p>	<p style="text-align: center;"><b>CUD38</b></p>  <p style="text-align: right;">AMP_JPT_02F_B</p>	<p style="text-align: center;"><b>CUD39</b></p>  <p style="text-align: right;">AMP_JPT_04F_B_BOSCH</p>	<p style="text-align: center;"><b>CUD40</b></p>  <p style="text-align: right;">AMP_EMS_05F_BSH</p>

MFI CONTROL SYSTEM

MFI CONTROL SYSTEM (D4FB) (6)

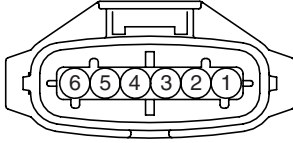
SD313-24

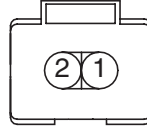
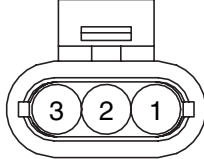
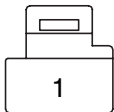
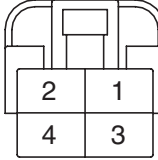
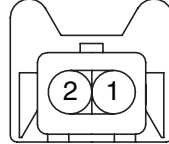
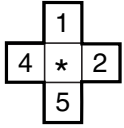
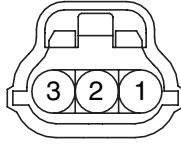
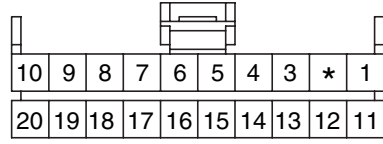
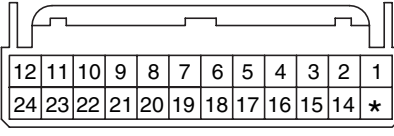
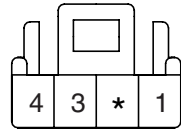
<p><b>CUD44</b></p>  <p>AMP_6F</p>	<p><b>CUD49</b></p>  <p>KET_250DL_02F_W</p>	<p><b>CUD51</b></p>  <p>AMP_090WP_02F_B</p>	<p><b>CUD53</b></p>  <p>AMP_1.5WP_03F_B</p>
<p><b>CUD55</b></p>  <p>KET_58L_1F_B</p>	<p><b>CUD58</b></p>  <p>KET_250DL_04F_W</p>	<p><b>CUD61</b></p>  <p>AMP_JPT_02F_B</p>	<p><b>CUD70</b></p>  <p>CR05F019</p>
<p><b>E24</b></p>  <p>KET_040WP_03F_B</p>	<p><b>M01-A</b></p>  <p>AMP_040_MK1_20F</p>	<p><b>M01-B</b></p>  <p>AMP_025_I/O_24F</p>	<p><b>M09</b></p>  <p>KET_SP_04F_W</p>



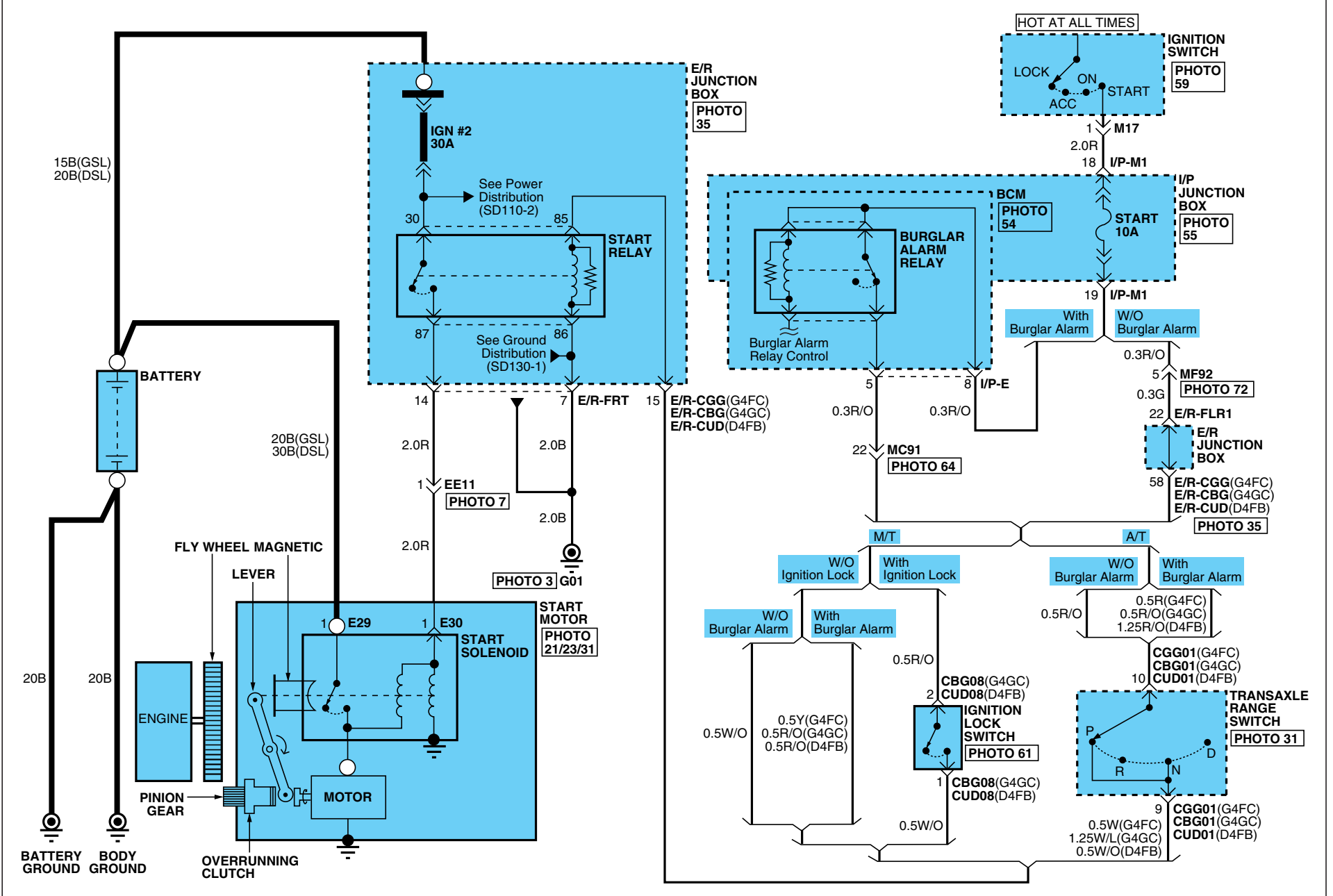

STARTING SYSTEM E0B56F61

STARTING SYSTEM (1)

SD360-1

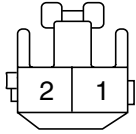

STARTING SYSTEM

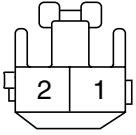
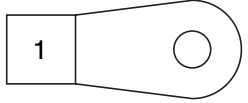
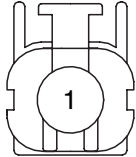
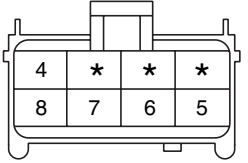
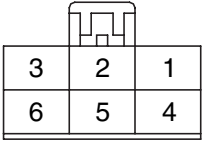
STARTING SYSTEM (2)			SD360-2
<p><b>CGG01</b></p>  <p>KET_SSD_10F_B</p>	<p><b>CBG01</b></p>  <p>KET_SSD_10F_B</p>	<p><b>CBG08</b></p>  <p>KET_090II_02F_W</p>	<p><b>CUD01</b></p>  <p>KET_SSD_10F_B</p>
<p><b>CUD08</b></p>  <p>KET_090II_02F_W</p>	<p><b>E29</b></p>  <p>CR01F002</p>	<p><b>E30</b></p>  <p>KET_58X_01F_B</p>	<p><b>I/P-E</b></p>  <p>PKD_MIC64_08F_B</p>
<p><b>M17</b></p>  <p>KUM_DSD_06F_W</p>	<p><b>BLANK</b></p>	<p><b>BLANK</b></p>	<p><b>BLANK</b></p>

FUEL FILTER HEATING SYSTEM E9FD49D0

FUEL FILTER HEATING SYSTEM (D4FB) (1)

SD361-1

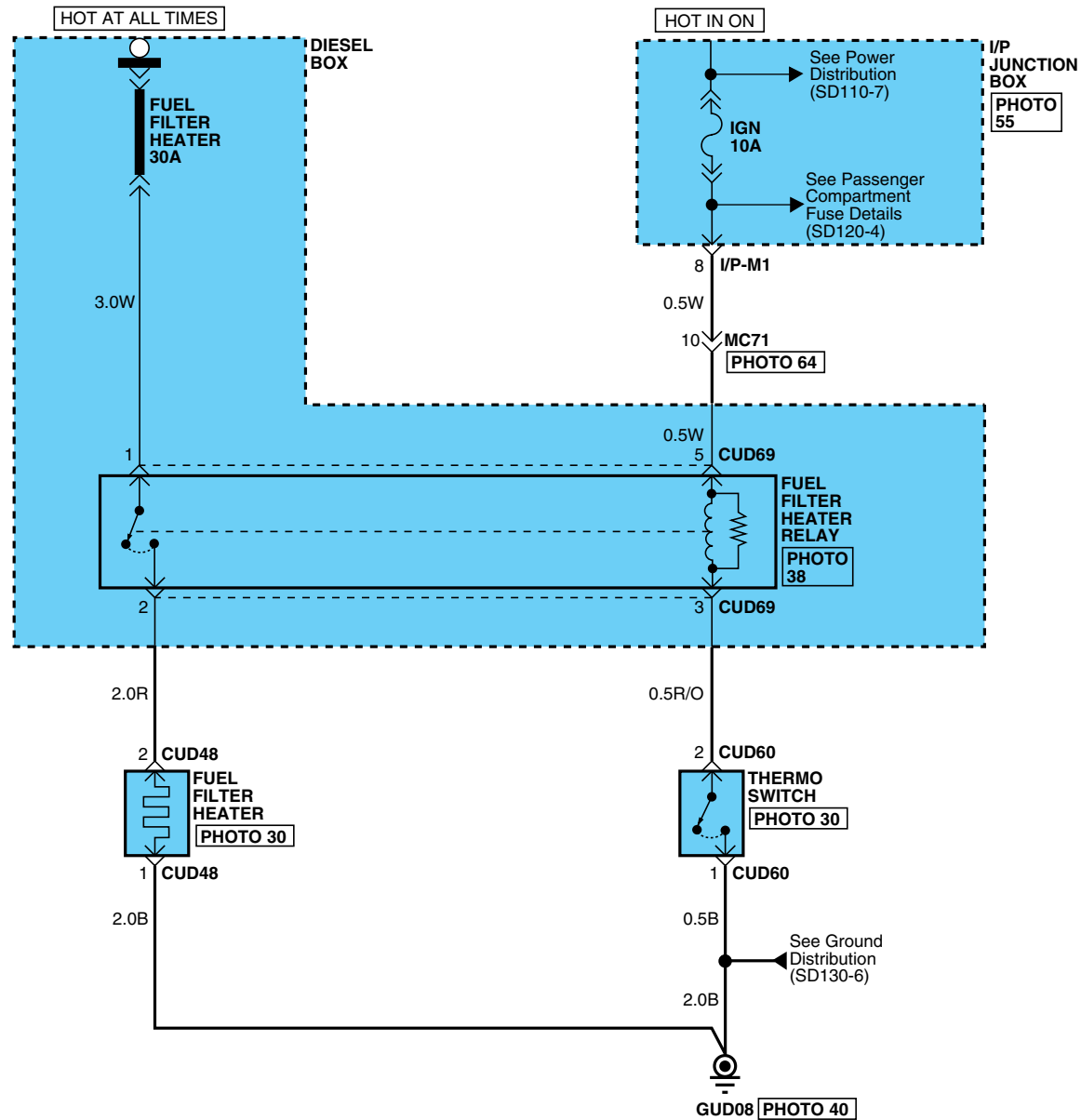

FUEL FILTER HEATING SYSTEM

FUEL FILTER HEATING SYSTEM (D4FB) (2)

SD361-2

CUD48

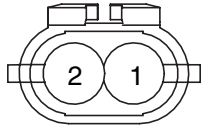

PKD\_280WP\_02F\_B

CUD60

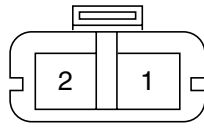

AMP\_1.5WP\_02F\_B

CUD69

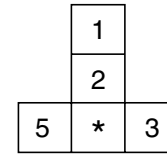

CR05F011

BLANK

CHARGING SYSTEM E9E657E7

CHARGING SYSTEM (1)

SD373-1

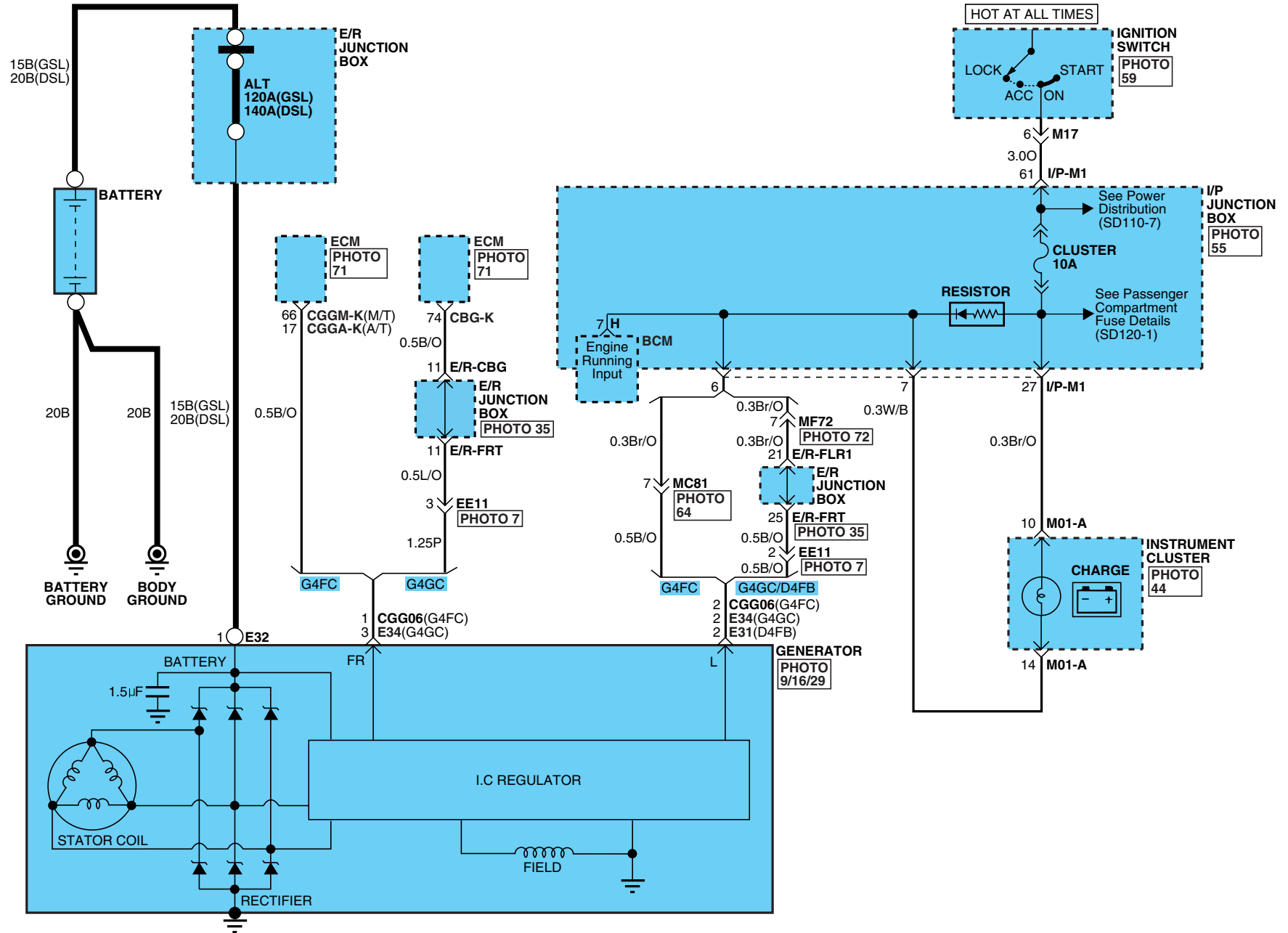



CHARGING SYSTEM

CHARGING SYSTEM (2)

SD373-2

CGGA-K

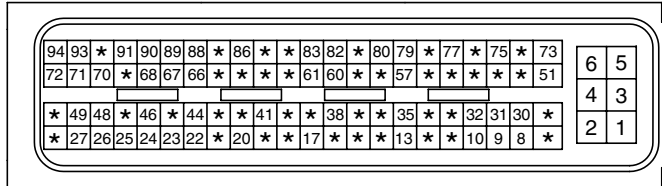

AMP\_ECU\_94F\_B

CGGM-K

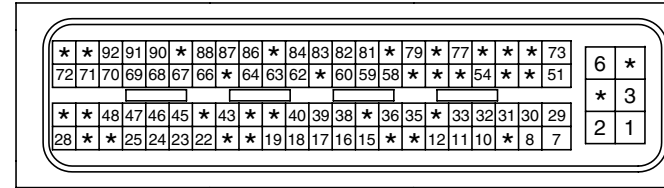

AMP\_ECU\_94F\_B

CBG-K

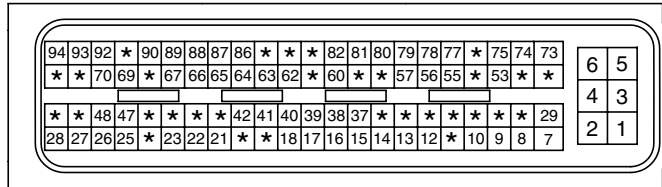

AMP\_ECU\_94F\_B

CGG06

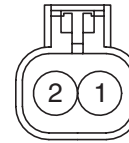

KET\_58X\_02F\_B

E31

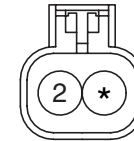

KET\_58X\_02F\_B

E32

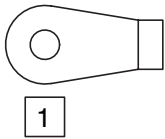

CR01F052

E34

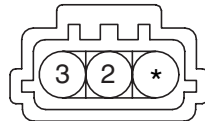

SUM\_ALTPW\_03F\_Gr

M01-A

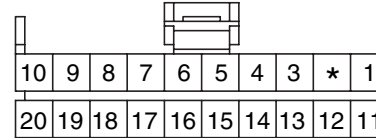

AMP\_040\_MK1\_20F

M17

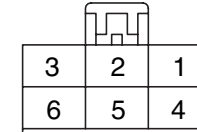

KUM\_DSD\_06F\_W

VEHICLE SPEED SYSTEM

EED2498D

VEHICLE SPEED SYSTEM (1)

SD436-1

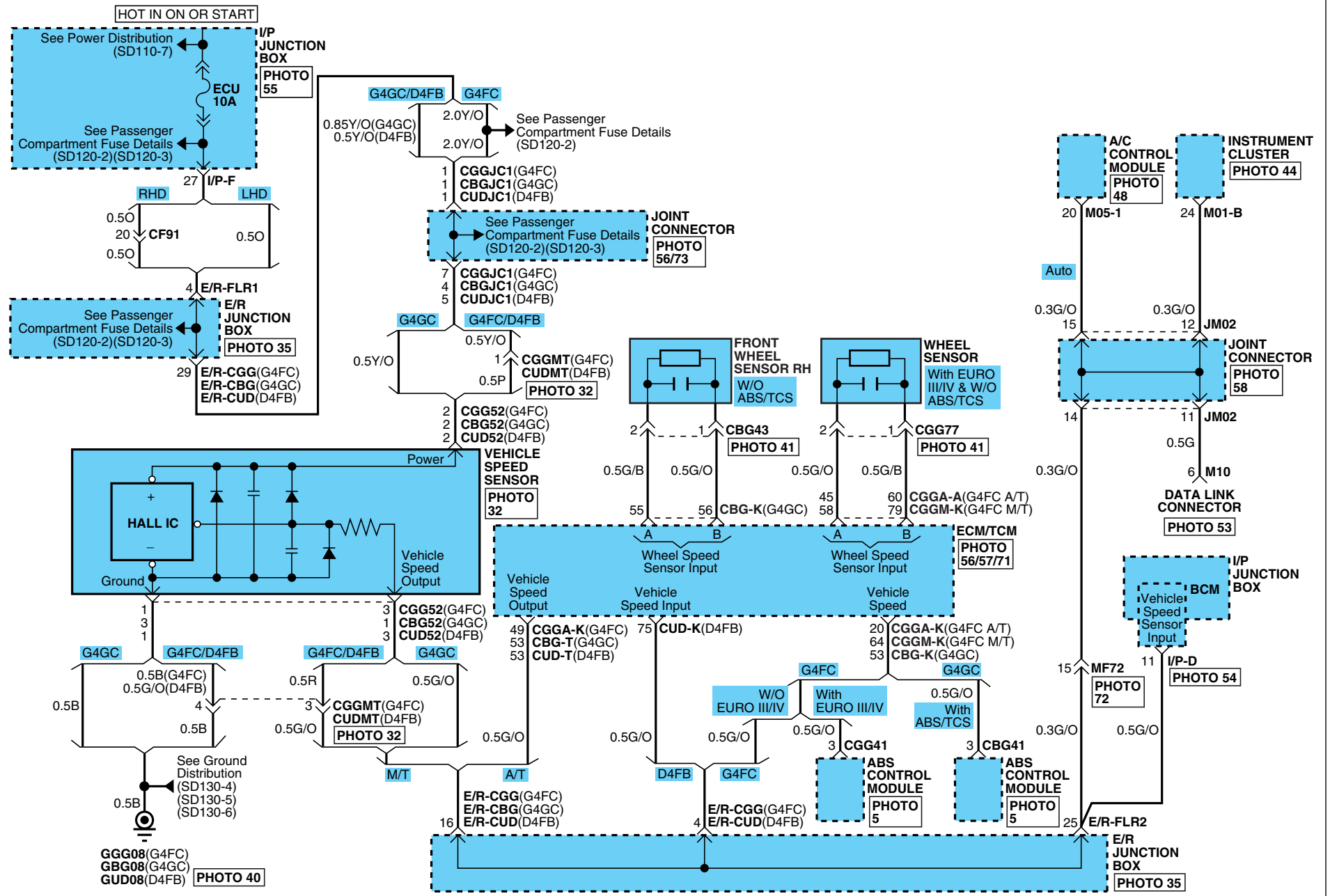

VEHICLE SPEED SYSTEM

VEHICLE SPEED SYSTEM (2)

SD436-2

CGGA-A

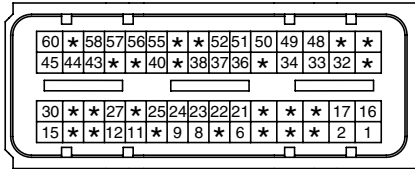

AMP\_ECU\_60F\_B

CGGA-K

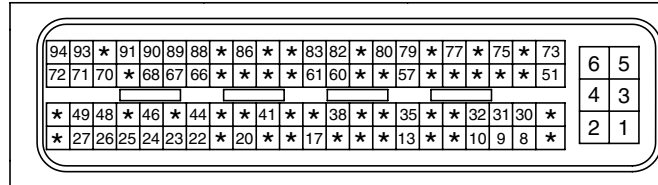

AMP\_ECU\_94F\_B

BLANK

CGGM-K

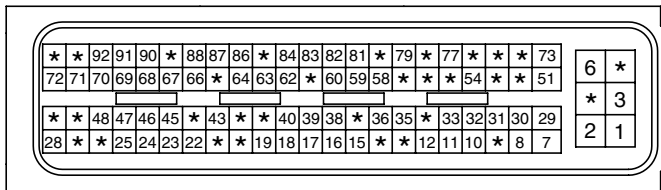

AMP\_ECU\_94F\_B

CBG-K

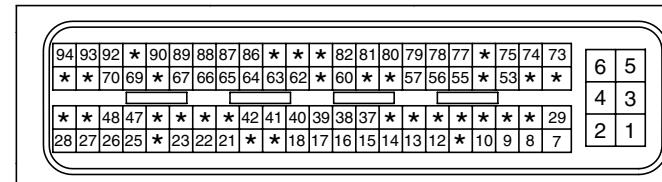

AMP\_ECU\_94F\_B

CBG-T

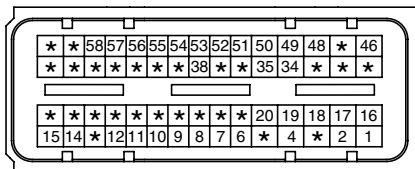

AMP\_ECU\_60F\_B

CUD-K

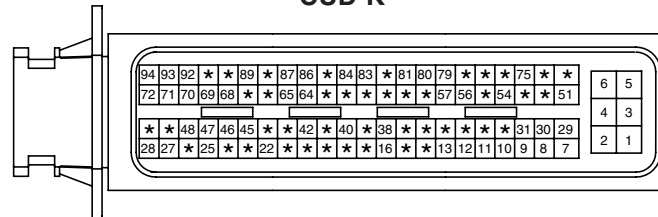

AMP\_ECU\_94F\_B

BLANK

CUD-T

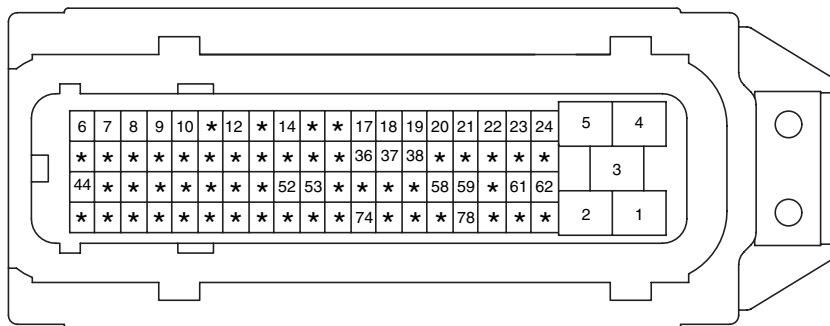

KET\_ECU\_81F\_B

CGG41

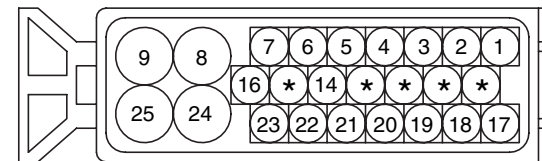

AMP\_ABSWP\_25F\_B\_GER

CGG52

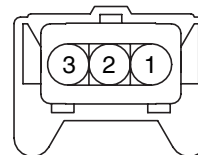

AMP\_JPT\_03F\_B\_S1

CGG77

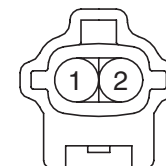

KET\_090IWP\_02M\_B

VEHICLE SPEED SYSTEM

VEHICLE SPEED SYSTEM (3)

SD436-3

CBG41

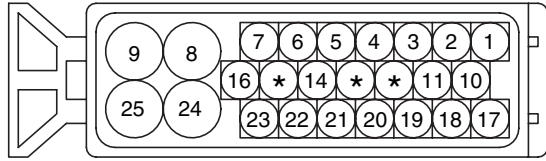

AMP\_ABSWP\_25F\_B

CBG43

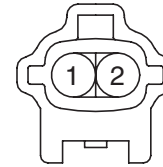

KET\_090IWP\_02M\_B

CBG52

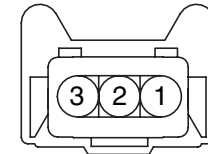

AMP\_JPT\_03F\_B

CUD52

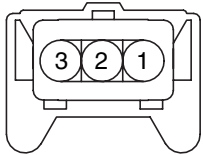

AMP\_JPT\_03F\_B\_S1

I/P-D

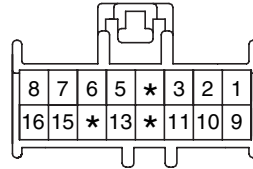

PKD\_ASM\_16F\_G

M01-B

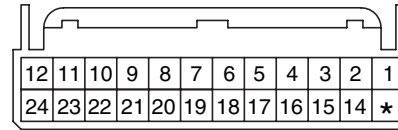

AMP\_025\_I/O\_24F

M05-1

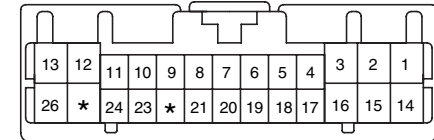

KET\_PCB\_26F

M10

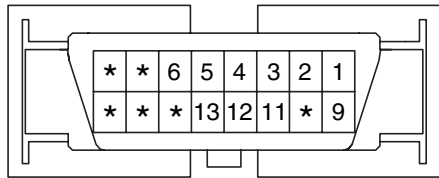

MLX\_OBDII\_16F\_B\_SIN

BLANK

BLANK

BLANK

**VEHICLE SPEED SYSTEM**

**VEHICLE SPEED SYSTEM (4)**

**SD436-4**

**MEMO**

# AUTOMATIC TRANSAXLE CONTROL SYSTEM

EE343D33

## AUTOMATIC TRANSAXLE CONTROL SYSTEM (G4FC) (1)

SD450-1

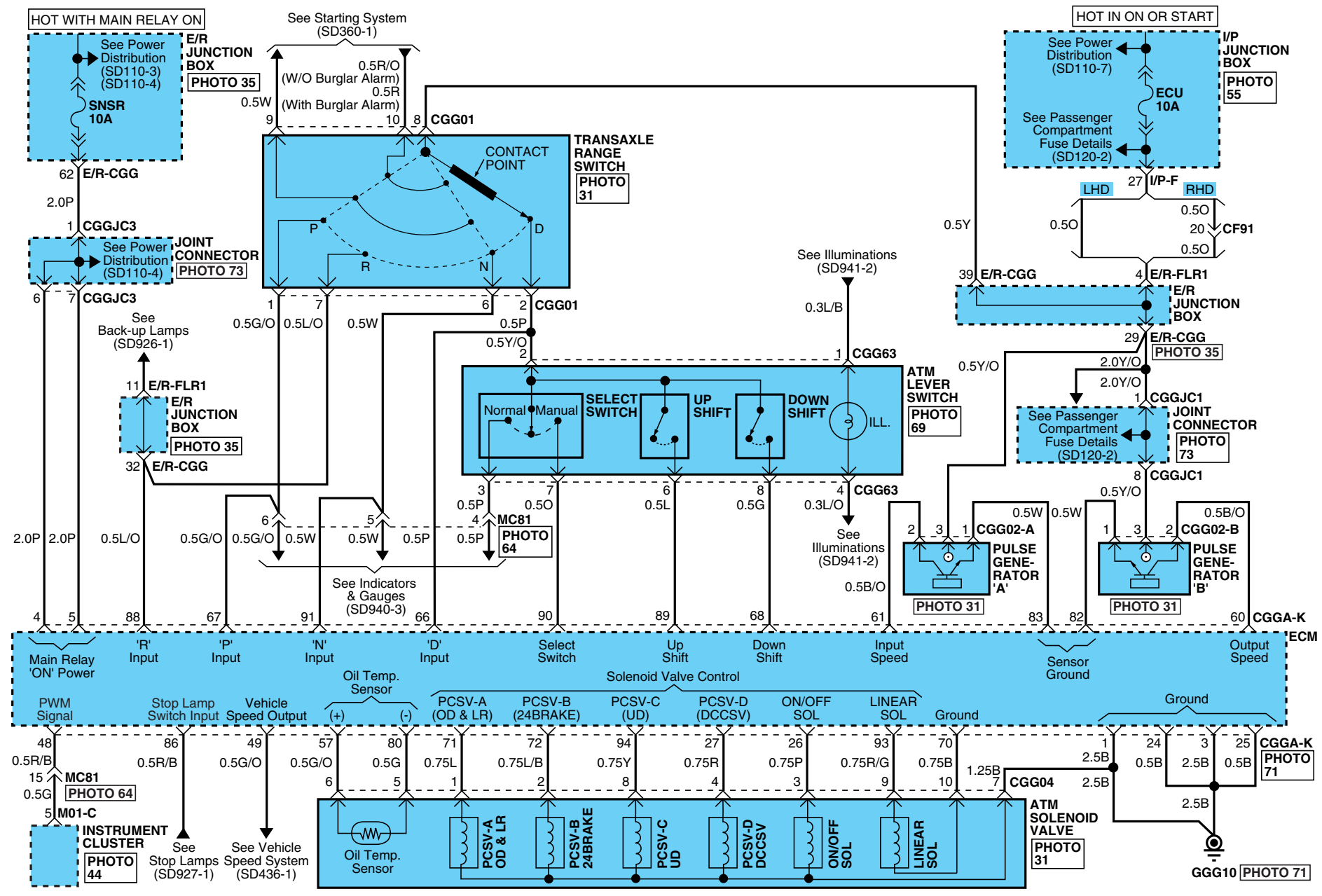

**AUTOMATIC TRANSAXLE CONTROL SYSTEM**

**AUTOMATIC TRANSAXLE CONTROL SYSTEM (G4FC) (2)**

**SD450-2**

**CGGA-K**

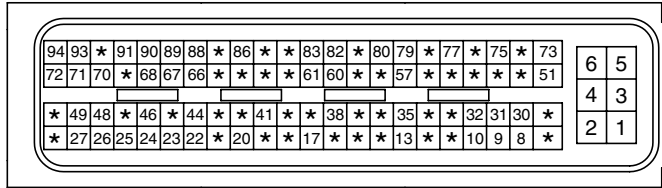

AMP\_ECU\_94F\_B

**CGG01**



KET\_SSD\_10F\_B

**CGG02-A**

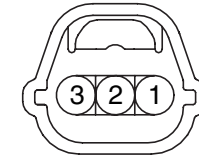

KET\_SSD\_03F\_Gr

**CGG02-B**

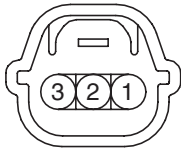

KET\_SSD\_03F\_B

**CGG04**

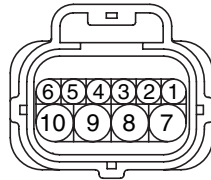

FCI\_FPC\_10F\_B

**CGG63**

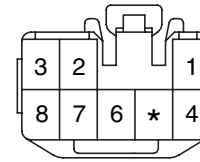

KET\_090II\_08F\_W

**M01-C**

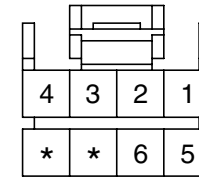

AMP\_040\_MK\_08F

AUTOMATIC TRANSAXLE CONTROL SYSTEM

EB3ACB25

AUTOMATIC TRANSAXLE CONTROL SYSTEM (G4GC) (1)

SD450-3

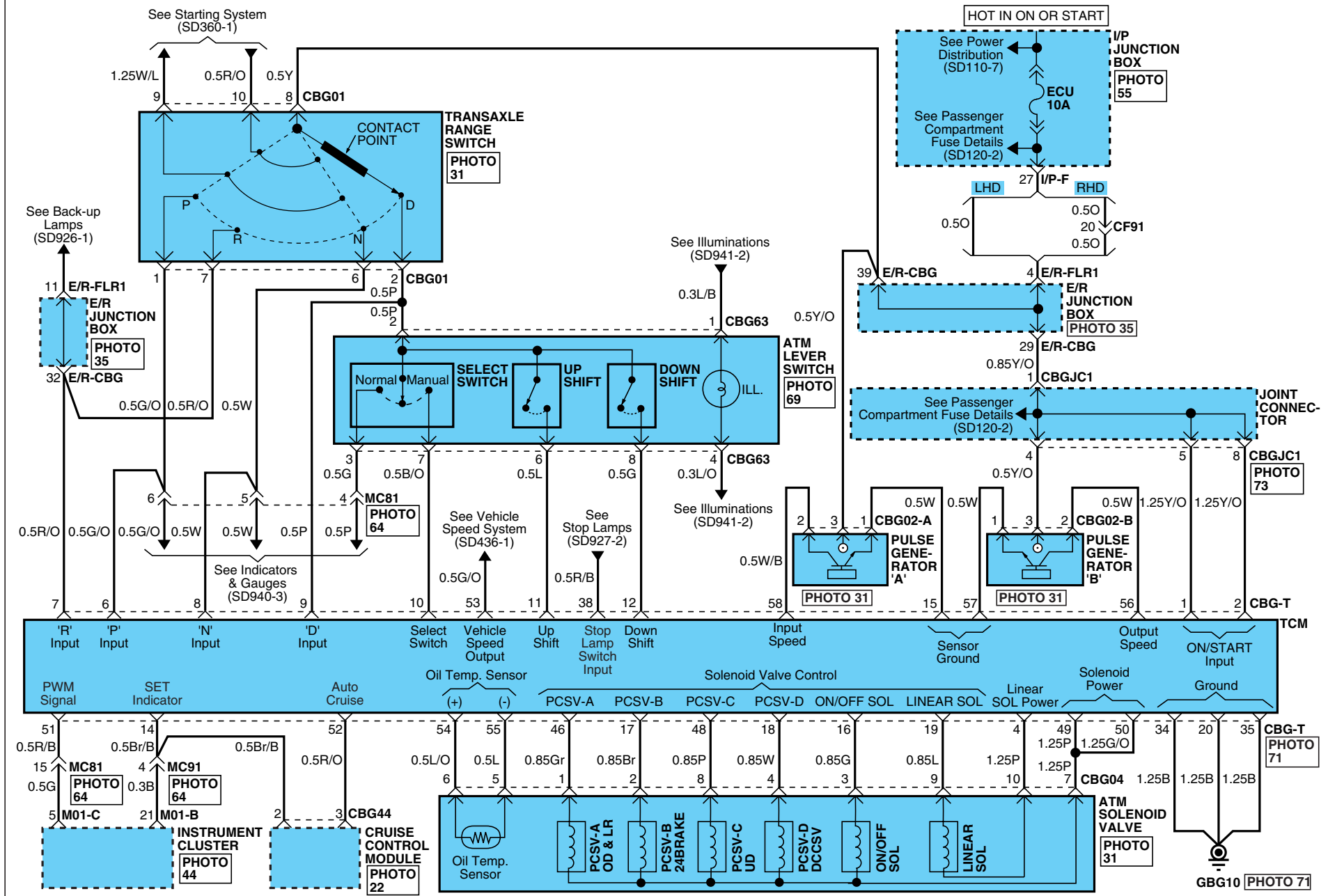





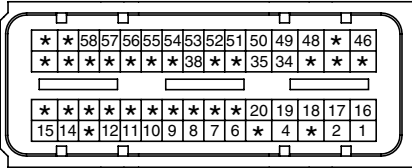

**AUTOMATIC TRANSAXLE CONTROL SYSTEM**

**AUTOMATIC TRANSAXLE CONTROL SYSTEM (G4GC) (2)**

**SD450-4**

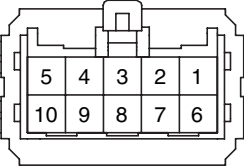
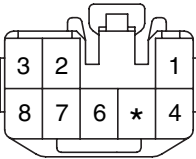
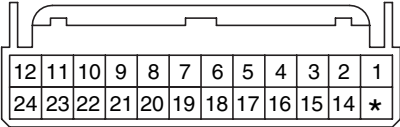
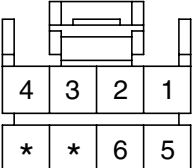
<p align="center"><b>CBG-T</b></p>  <p align="center">AMP_ECU_60F_B</p>	<p align="center"><b>CBG01</b></p>  <p align="center">KET_SSD_10F_B</p>	<p align="center"><b>CBG02-A</b></p>  <p align="center">KET_SSD_03F_Gr</p>	<p align="center"><b>CBG02-B</b></p>  <p align="center">KET_SSD_03F_B</p>
<p align="center"><b>CBG04</b></p>  <p align="center">FCI_FPC_10F_B</p>	<p align="center"><b>CBG44</b></p>  <p align="center">PKD_150W_10F_B</p>	<p align="center"><b>CBG63</b></p>  <p align="center">KET_090II_08F_W</p>	<p align="center"><b>M01-B</b></p>  <p align="center">AMP_025_I/O_24F</p>
<p align="center"><b>M01-C</b></p>  <p align="center">AMP_040_MK_08F</p>	<p align="center"><b>BLANK</b></p>	<p align="center"><b>BLANK</b></p>	<p align="center"><b>BLANK</b></p>

AUTOMATIC TRANSAXLE CONTROL SYSTEM

E9E317D7

AUTOMATIC TRANSAXLE CONTROL SYSTEM (D4FB) (1)

SD450-5

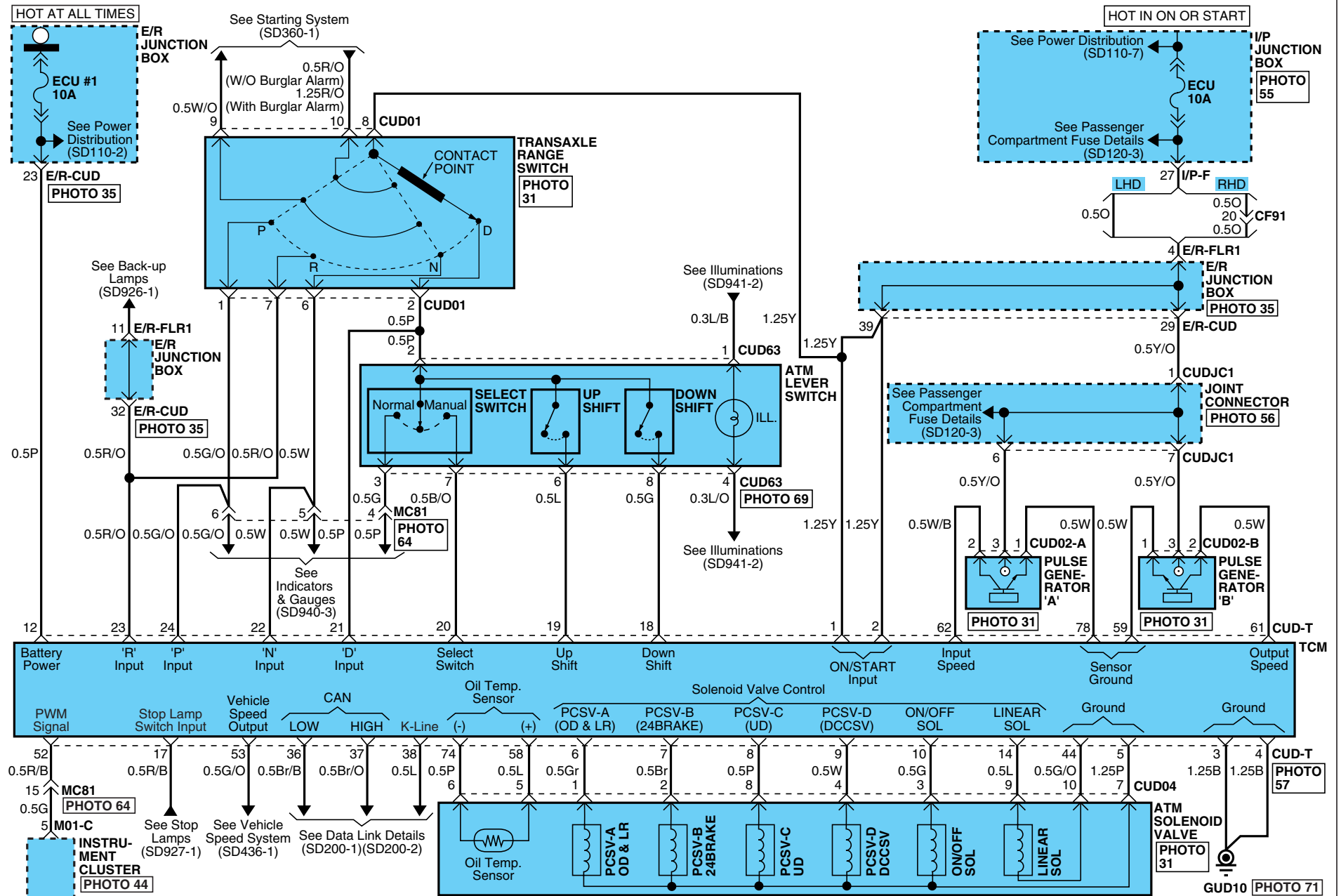

**AUTOMATIC TRANSAXLE CONTROL SYSTEM**

**AUTOMATIC TRANSAXLE CONTROL SYSTEM (D4FB) (2)**

**SD450-6**

**CUD-T**

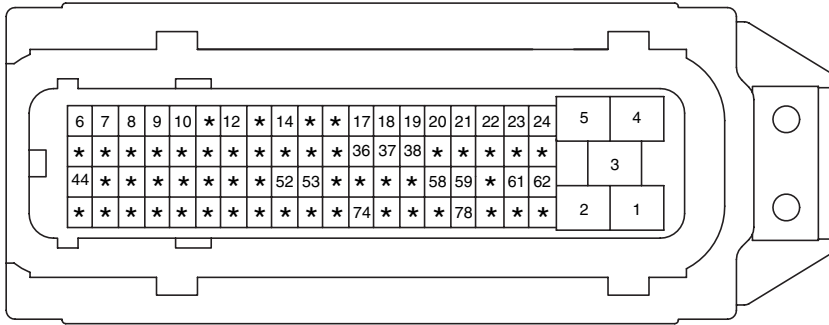

KET\_ECU\_81F\_B

**CUD01**



KET\_SSD\_10F\_B

**CUD02-A**



KET\_SSD\_03F\_Gr

**CUD02-B**

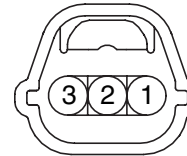

KET\_SSD\_03F\_B

**CUD04**

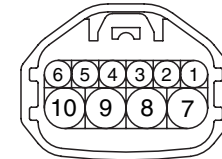

FCL\_10F\_B

**CUD63**

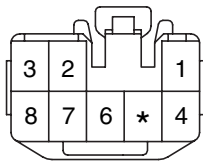

KET\_090II\_08F\_W

**M01-C**

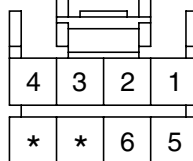

AMP\_040\_MK\_08F

**BLANK**

**BLANK**

AIR BAG SYSTEM (SRS) EFD3E12A

AIR BAG SYSTEM (SRS) (1)

SD569-1

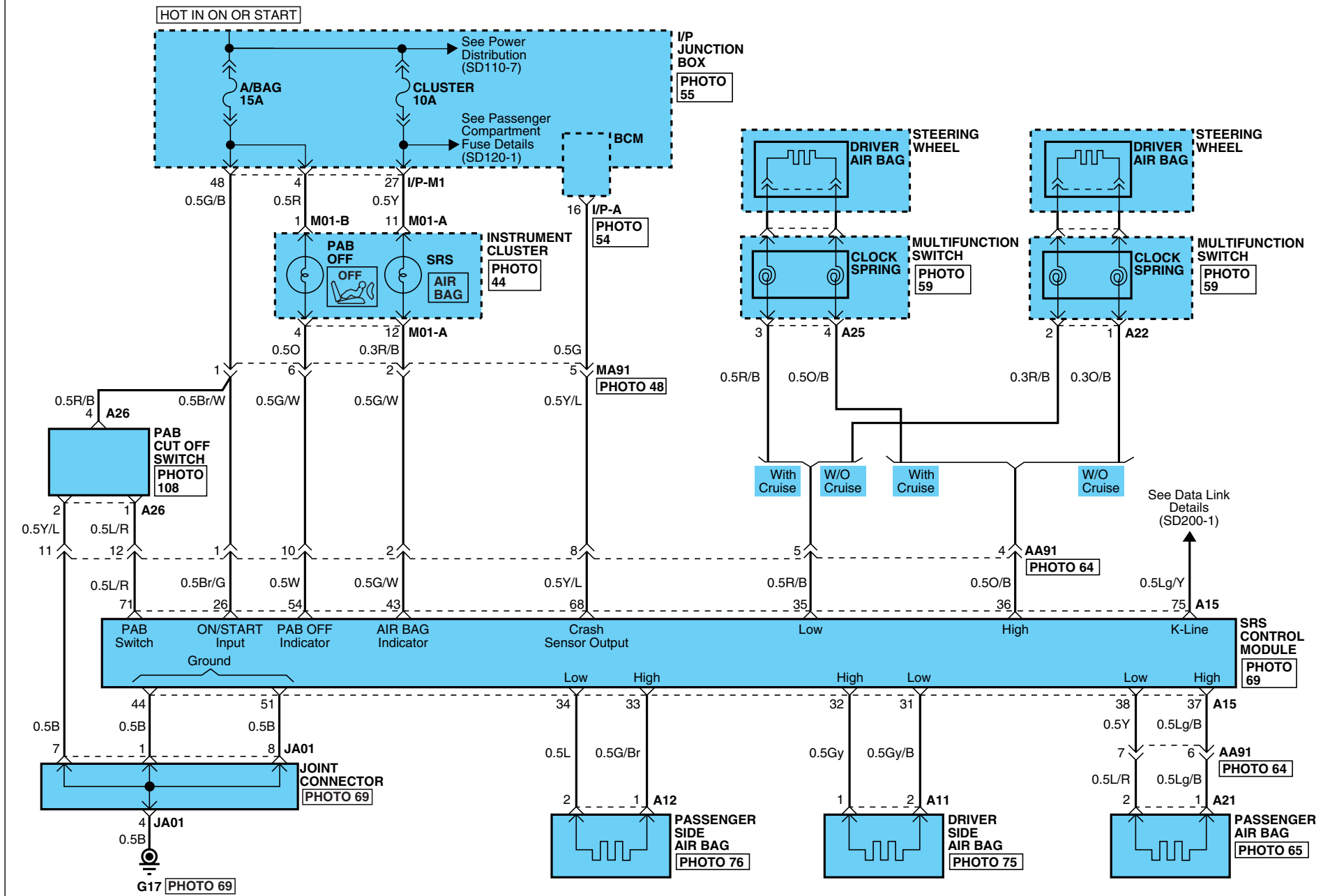

# AIR BAG SYSTEM (SRS)

## AIR BAG SYSTEM (SRS) (2)



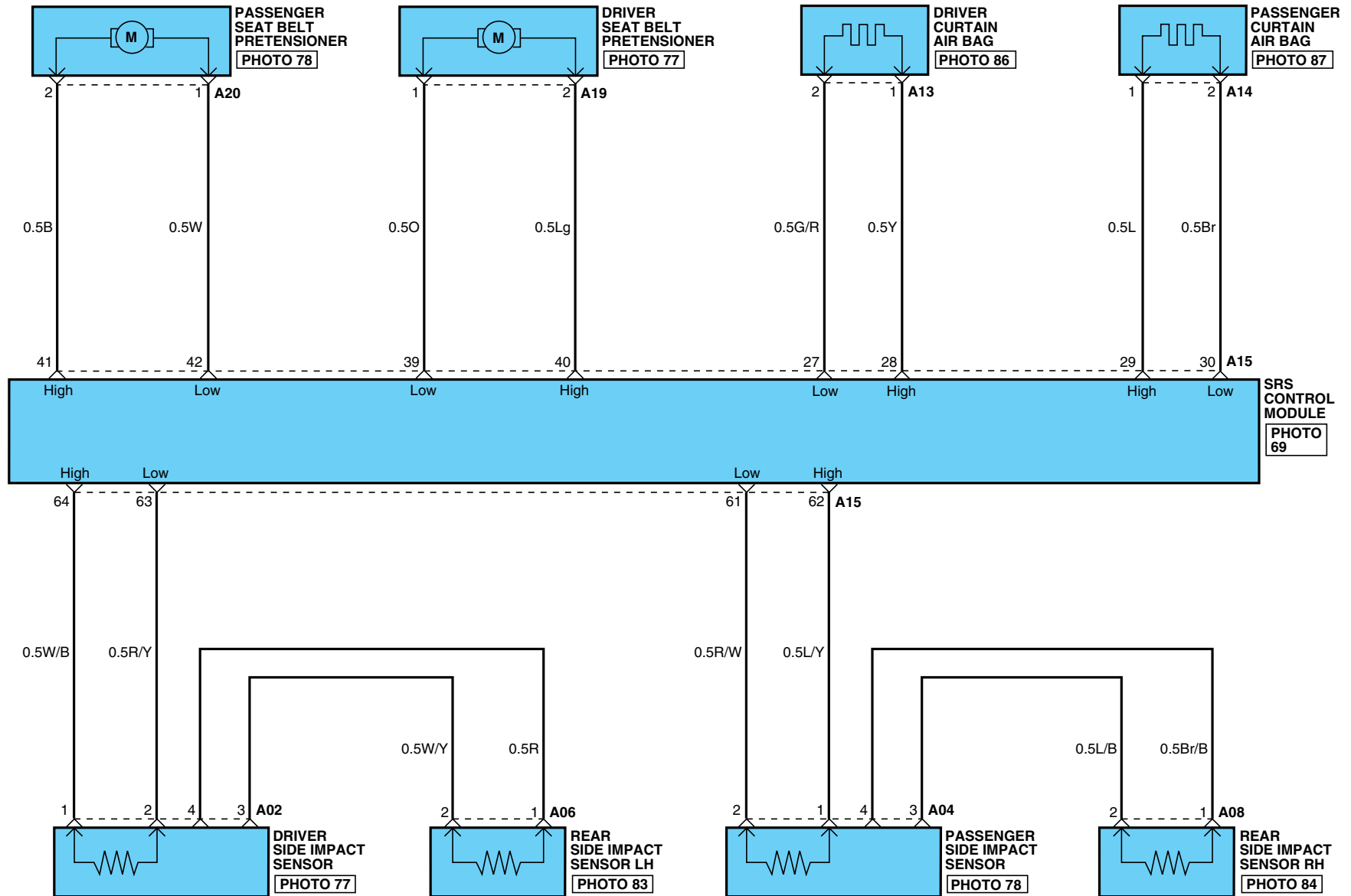

SD569-2

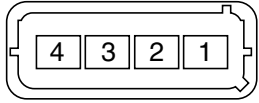
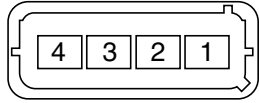
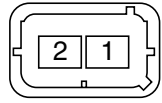
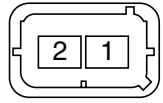

**AIR BAG SYSTEM (SRS)**

**AIR BAG SYSTEM (SRS) (3)**

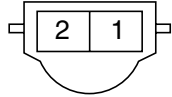
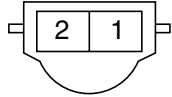
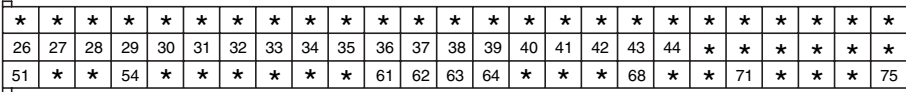
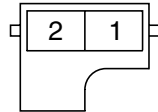
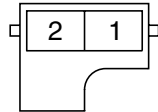
**SD569-3**

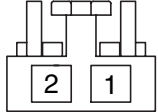
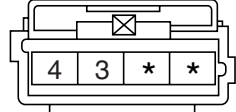
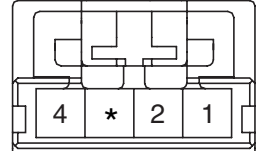
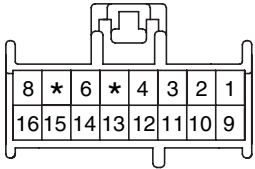
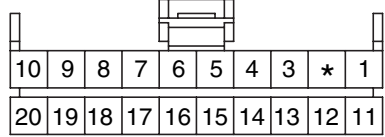
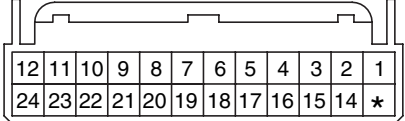
<b>A02</b>  YAZ_ABAG_04F	<b>A04</b>  YAZ_ABAG_04F	<b>A06</b>  YAZ_ABAG_02F	<b>A08</b>  YAZ_ABAG_02F
<b>A11</b>  YAZ_040WP_02F	<b>A12</b>  YAZ_040WP_02F	<b>A13</b>  AMPHENOL_M_CA_252_92_2250	<b>A14</b>  AMPHENOL_M_CA_252_92_2250
<b>A15</b>  SIEABG_75F_ABG		<b>A19</b>  AMP_SQUIB_02F	<b>A20</b>  AMP_SQUIB_02F
<b>A21</b>  YAZ_040WP_02F	<b>A22</b>  YAZ_DAB_02F_Y	<b>A25</b>  YZK_040I1_04F_Y_ABAG	<b>A26</b>  AMP_MQS_04F
<b>I/P-A</b>  PKD_ASM_16F_B	<b>M01-A</b>  AMP_040_MK1_20F	<b>M01-B</b>  AMP_025_I/O_24F	<b>BLANK</b>

**AIR BAG SYSTEM (SRS)**

**AIR BAG SYSTEM (SRS) (4)**

**SD569-4**

**MEMO**

ABS (ANTI-LOCK BRAKE SYSTEM)/TCS (TRACTION CONTROL SYSTEM) (1)

SD587-1

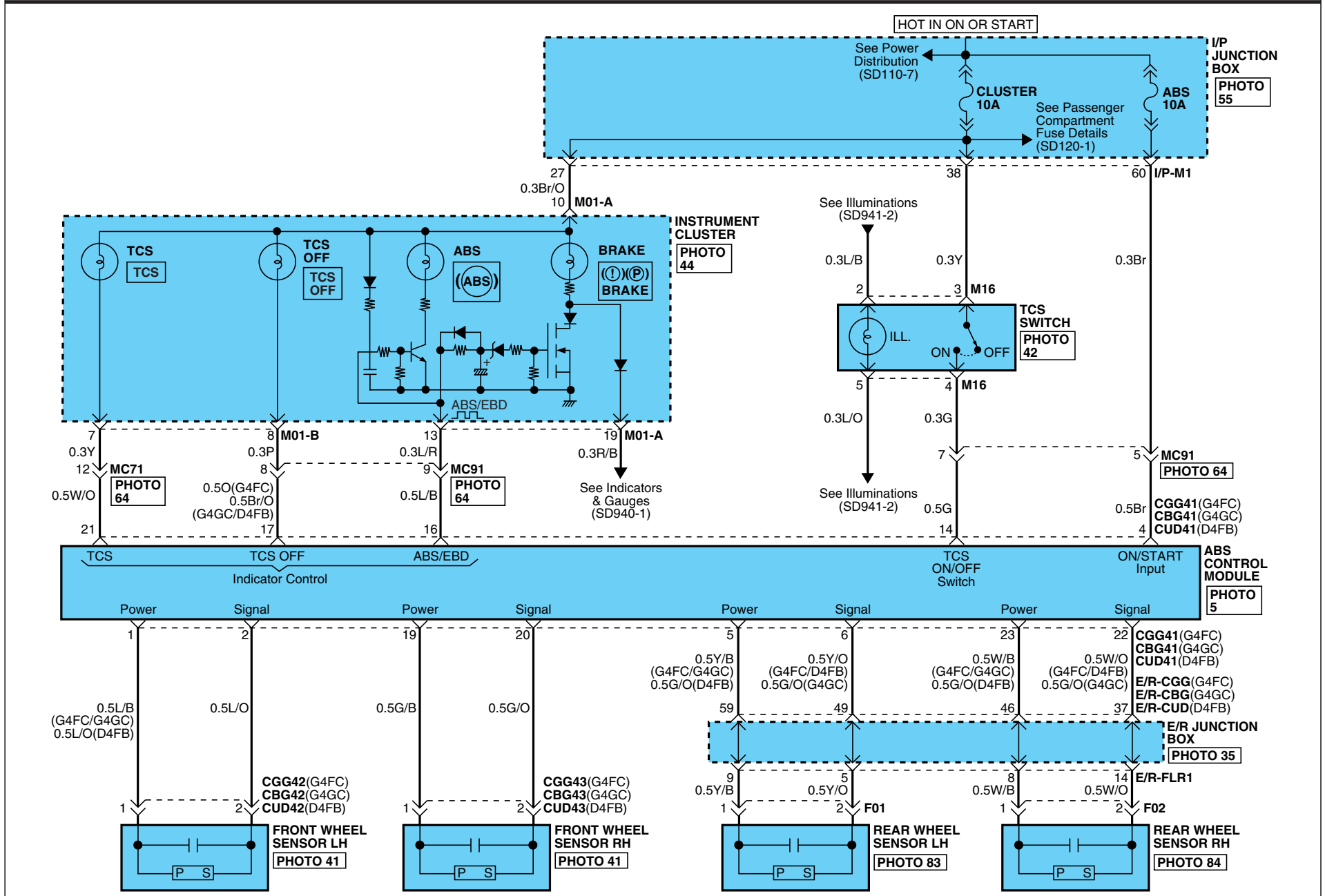





ABS (ANTI-LOCK BRAKE SYSTEM)/TCS (TRACTION CONTROL SYSTEM)

ABS (ANTI-LOCK BRAKE SYSTEM)/TCS (TRACTION CONTROL SYSTEM) (3)

SD587-3

CGGA-K

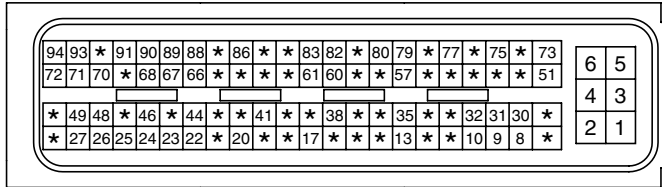

AMP\_ECU\_94F\_B

CGGM-K

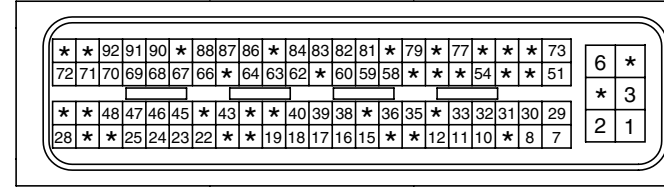

AMP\_ECU\_94F\_B

CBG-K

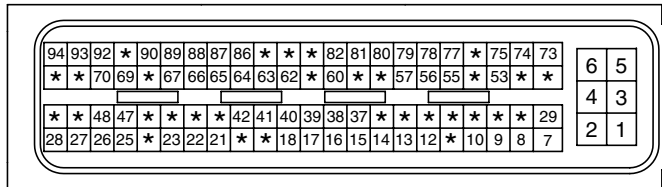

AMP\_ECU\_94F\_B

CGG41

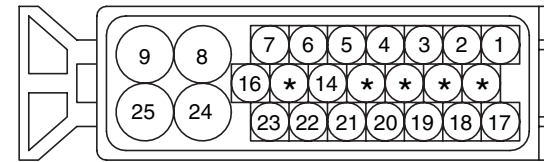

AMP\_ABSWP\_25F\_B\_GER

CGG42

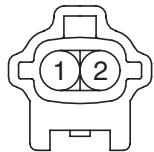

KET\_090IWP\_02M\_B

CGG43

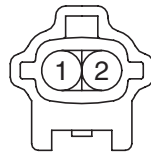

KET\_090IWP\_02M\_B

CGG47

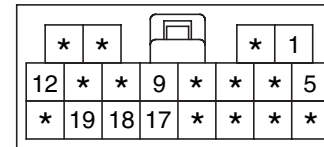

KET\_070\_20F\_B

CGG58A

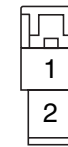

KET\_250DL\_2F\_W

CBG41

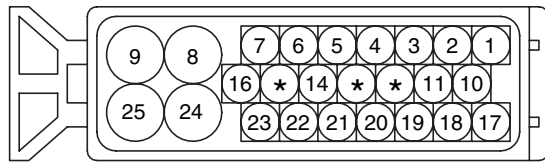

AMP\_ABSWP\_25F\_B

CBG42

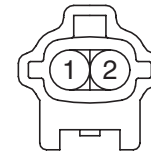

KET\_090IWP\_02M\_B

CBG43

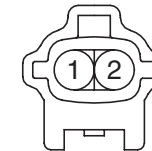

KET\_090IWP\_02M\_B

CBG47

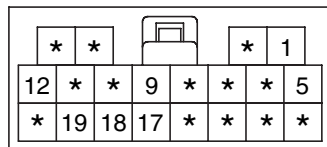

KET\_070\_20F\_B

CBG58

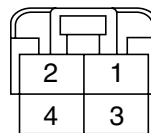

KET\_250DL\_04F



CBG58A



KET\_250DL\_02F\_W

BLANK

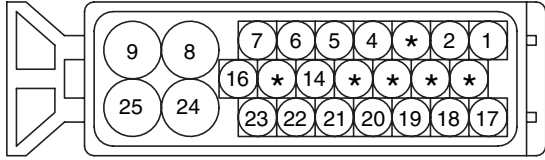
ABS (ANTI-LOCK BRAKE SYSTEM)/TCS (TRACTION CONTROL SYSTEM)

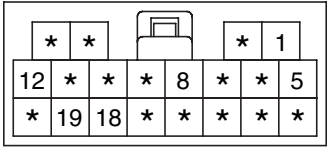
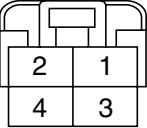
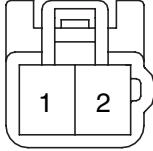
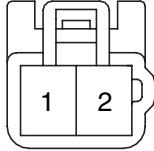
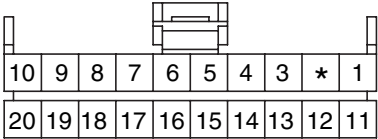
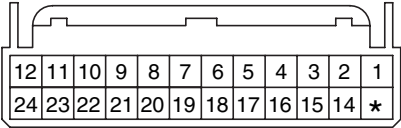
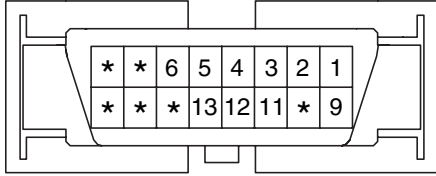
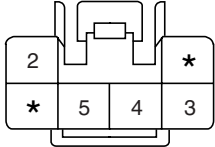
ABS (ANTI-LOCK BRAKE SYSTEM)/TCS (TRACTION CONTROL SYSTEM) (4)			SD587-4
<p><b>CUD41</b></p>  <p>AMP_ABSWP_25F_B_GER</p>		<p><b>CUD42</b></p>  <p>KET_090IWP_02M_B</p>	<p><b>CUD43</b></p>  <p>KET_090IWP_02M_B</p>
<p><b>CUD47</b></p>  <p>KET_070_20F_B</p>	<p><b>CUD58</b></p>  <p>KET_250DL_04F_W</p>	<p><b>F01</b></p>  <p>KET_090II_02M_W_R</p>	<p><b>F02</b></p>  <p>KET_090II_02M_W_R</p>
<p><b>M01-A</b></p>  <p>AMP_040_MK1_20F</p>	<p><b>M01-B</b></p>  <p>AMP_025_I/O_24F</p>	<p><b>M10</b></p>  <p>MLX_OBDII_16F_B_SIN</p>	<p><b>M16</b></p>  <p>KET_090II_06F_L</p>

TRUNK LID OPENER (1)

SD812-1

4DOOR

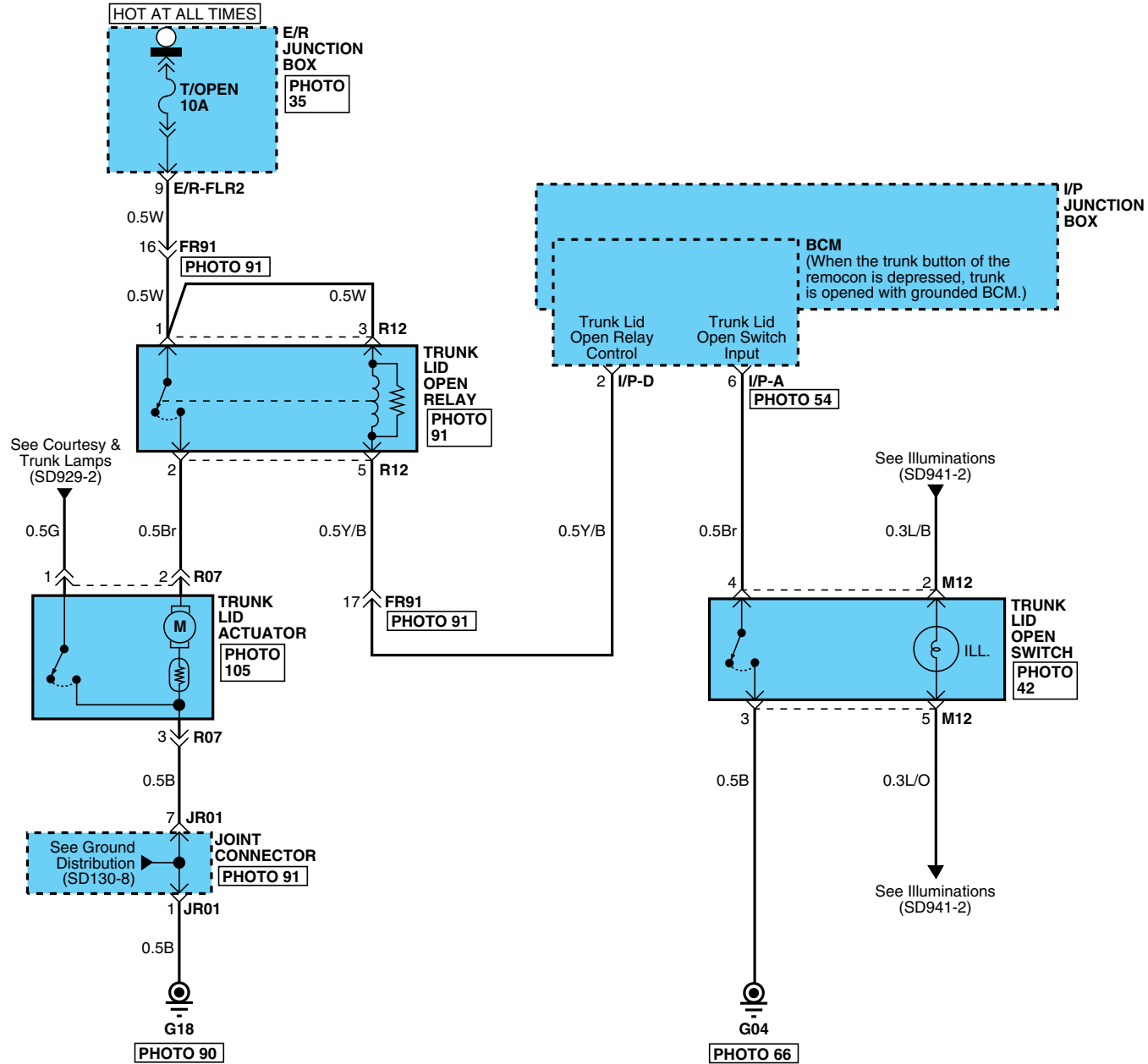

TRUNK LID OPENER

TRUNK LID OPENER (2)

SD812-2

I/P-A

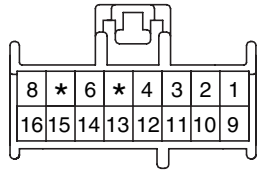

PKD\_ASM\_16F\_B

I/P-D

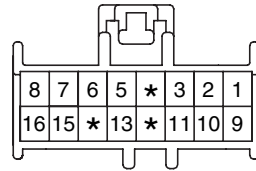

PKD\_ASM\_16F\_G

M12

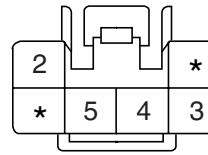

KET\_090II\_06F\_Y

R07

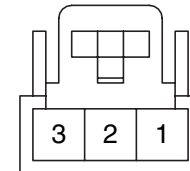

AMP\_070\_03F\_B

R12

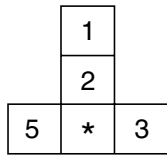

KET\_RELAY\_CONN\_B

BLANK

BLANK

BLANK

POWER DOOR LOCKS ED4C23D9

POWER DOOR LOCKS (1)

SD813-1

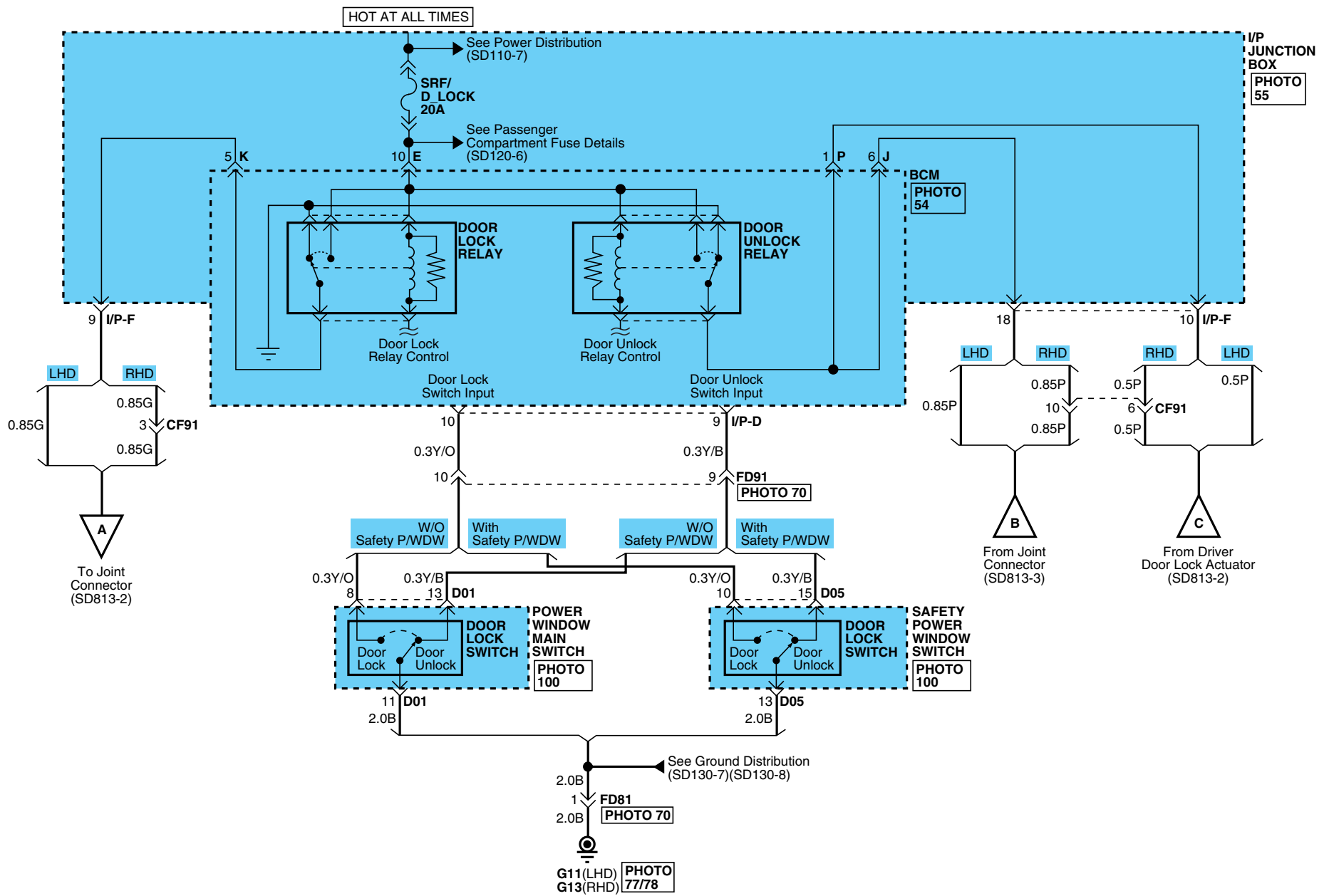

POWER DOOR LOCKS

POWER DOOR LOCKS (2)

SD813-2

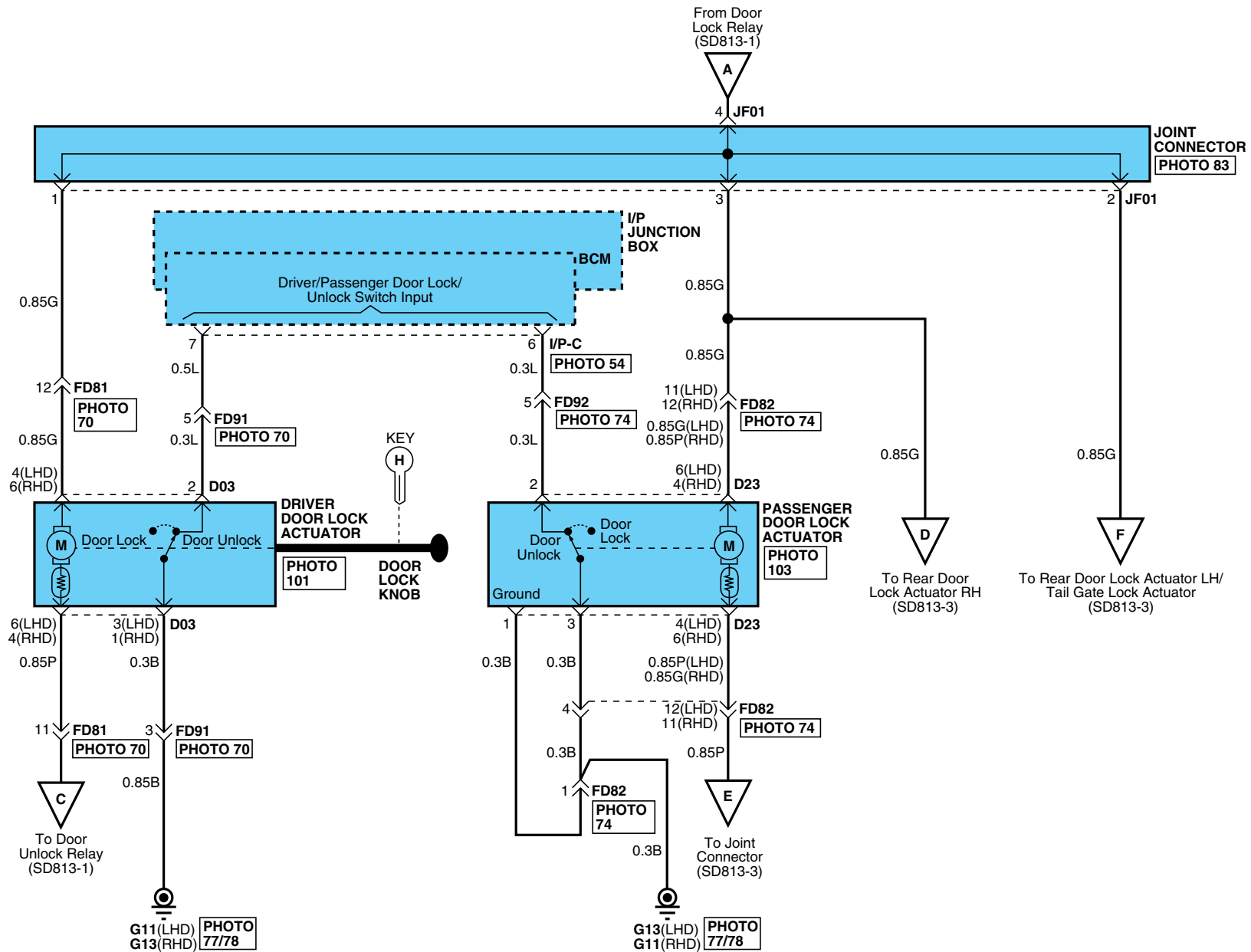

# POWER DOOR LOCKS

## POWER DOOR LOCKS (3)

SD813-3

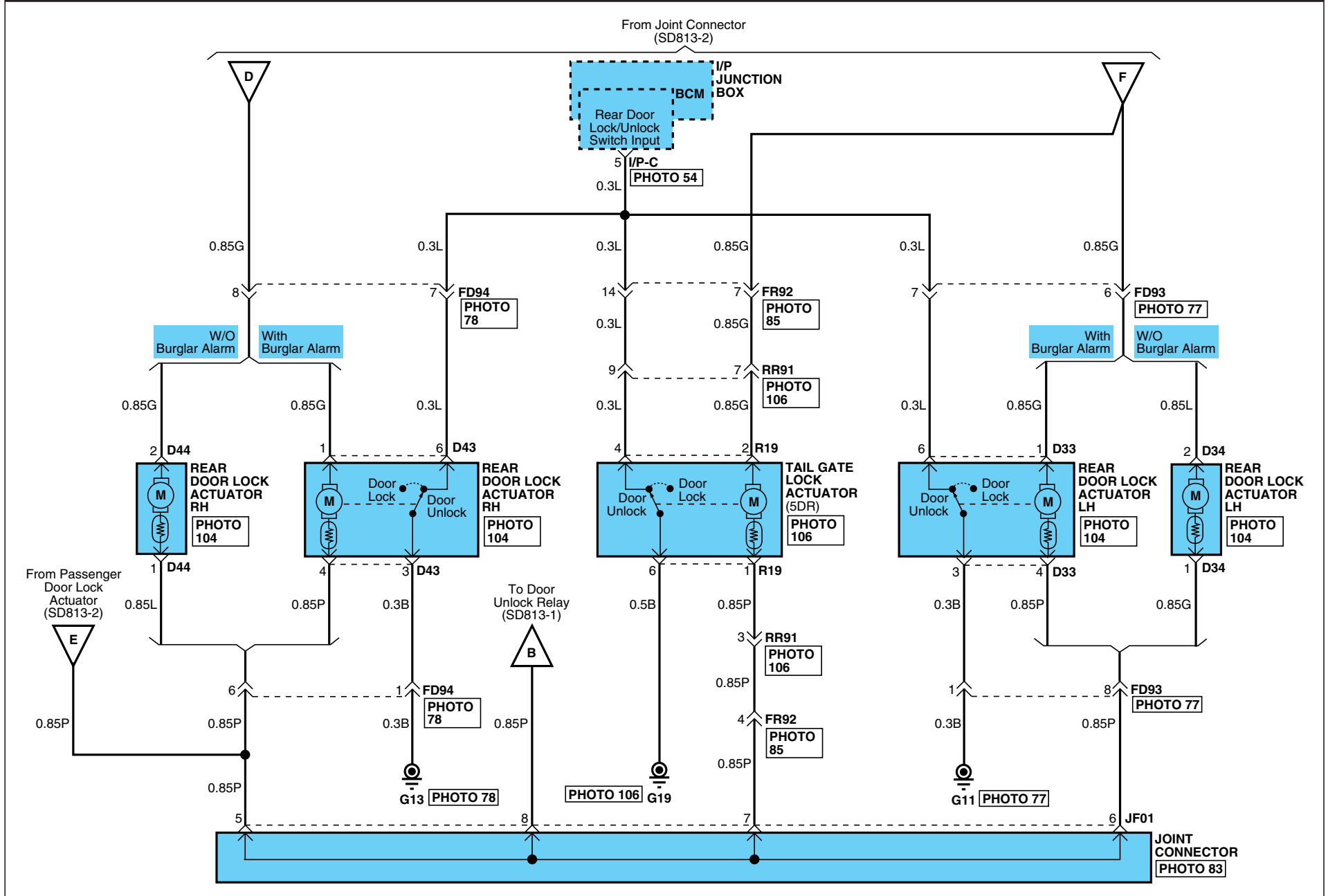







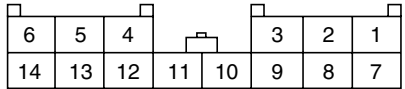

POWER DOOR LOCKS

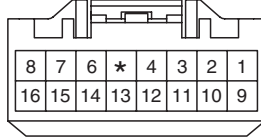

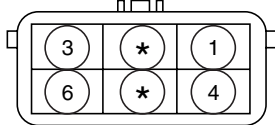
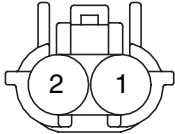
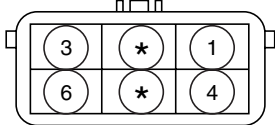
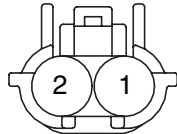
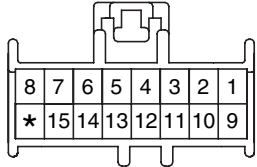
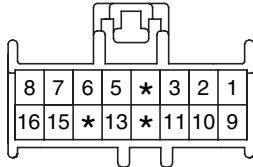





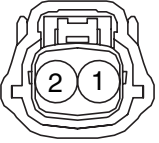

POWER DOOR LOCKS (4)

SD813-4

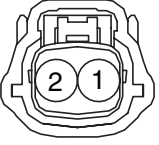
<p style="text-align: center;"><b>D01</b></p>  <p style="text-align: center;">KET_090II_14F_SW</p>	<p style="text-align: center;"><b>D03</b></p>  <p style="text-align: center;">KET_SSD_06F_B</p>	<p style="text-align: center;"><b>D05</b></p>  <p style="text-align: center;">AMP_090III_16F_W</p>	<p style="text-align: center;"><b>D23</b></p>  <p style="text-align: center;">KET_SSD_06F_B</p>
<p style="text-align: center;"><b>D33</b></p>  <p style="text-align: center;">KET_SWP_06F_B</p>	<p style="text-align: center;"><b>D34</b></p>  <p style="text-align: center;">KET_SWP_02F_B</p>	<p style="text-align: center;"><b>D43</b></p>  <p style="text-align: center;">KET_SWP_06F_B</p>	<p style="text-align: center;"><b>D44</b></p>  <p style="text-align: center;">KET_SWP_02F_B</p>
<p style="text-align: center;"><b>I/P-C</b></p>  <p style="text-align: center;">PKD_ASM_16F_BR</p>	<p style="text-align: center;"><b>I/P-D</b></p>  <p style="text-align: center;">PKD_ASM_16F_G</p>	<p style="text-align: center;"><b>R19</b></p>  <p style="text-align: center;">KET_SSD_06F_B</p>	<p style="text-align: center;"><b>BLANK</b></p>

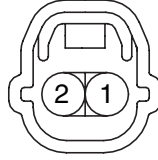

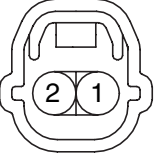
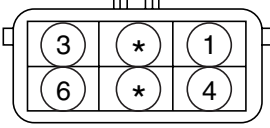
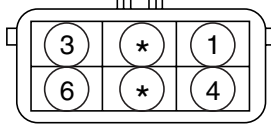
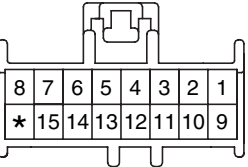
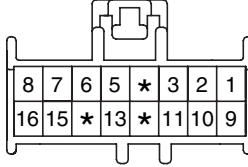
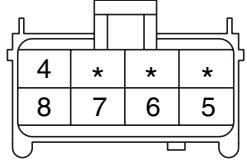
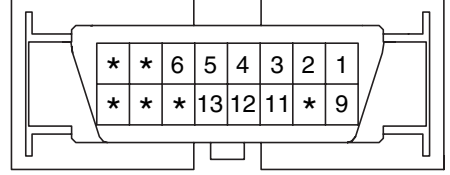
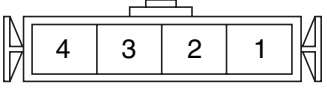
KEYLESS ENTRY & BURGLAR ALARM SYSTEM

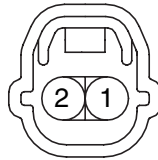
KEYLESS ENTRY & BURGLAR ALARM SYSTEM (2)				SD814-2
<p><b>CGG46</b></p>  <p>MLX_HORN_02F_B</p>	<p><b>CGG56</b></p>  <p>KUM_NMWP_01F_B</p>	<p><b>CBG46</b></p>  <p>MLX_HORN_02F_B</p>	<p><b>CBG56</b></p>  <p>KUM_NMWP_01F_B</p>	
<p><b>CUD46</b></p>  <p>MLX_HORN_02F_B</p>	<p><b>CUD56</b></p>  <p>KUM_NMWP_01F_B</p>	<p><b>D03</b></p>  <p>KET_SSD_06F_B</p>	<p><b>D04</b></p>  <p>KET_SSD_02F_B</p>	
<p><b>D23</b></p>  <p>KET_SSD_06F_B</p>	<p><b>D24</b></p>  <p>KET_SSD_02F_B</p>	<p><b>D33</b></p>  <p>KET_SWP_06F_B</p>	<p><b>D43</b></p>  <p>KET_SWP_06F_B</p>	
<p><b>I/P-C</b></p>  <p>PKD_ASM_16F_BR</p>	<p><b>I/P-D</b></p>  <p>PKD_ASM_16F_G</p>	<p><b>I/P-E</b></p>  <p>PKD_MIC64_08F_B</p>	<p><b>M10</b></p>  <p>MLX_OBDII_16F_B_SIN</p>	
<p><b>M25</b></p>  <p>KET</p>	<p><b>R04</b></p>  <p>KET_SSD_02F_B</p>	<p><b>R19</b></p>  <p>KET_SSD_06F_B</p>	<p><b>R21</b></p>  <p>KET_SSD_02F_B</p>	

SUNROOF (1)

SD816-1

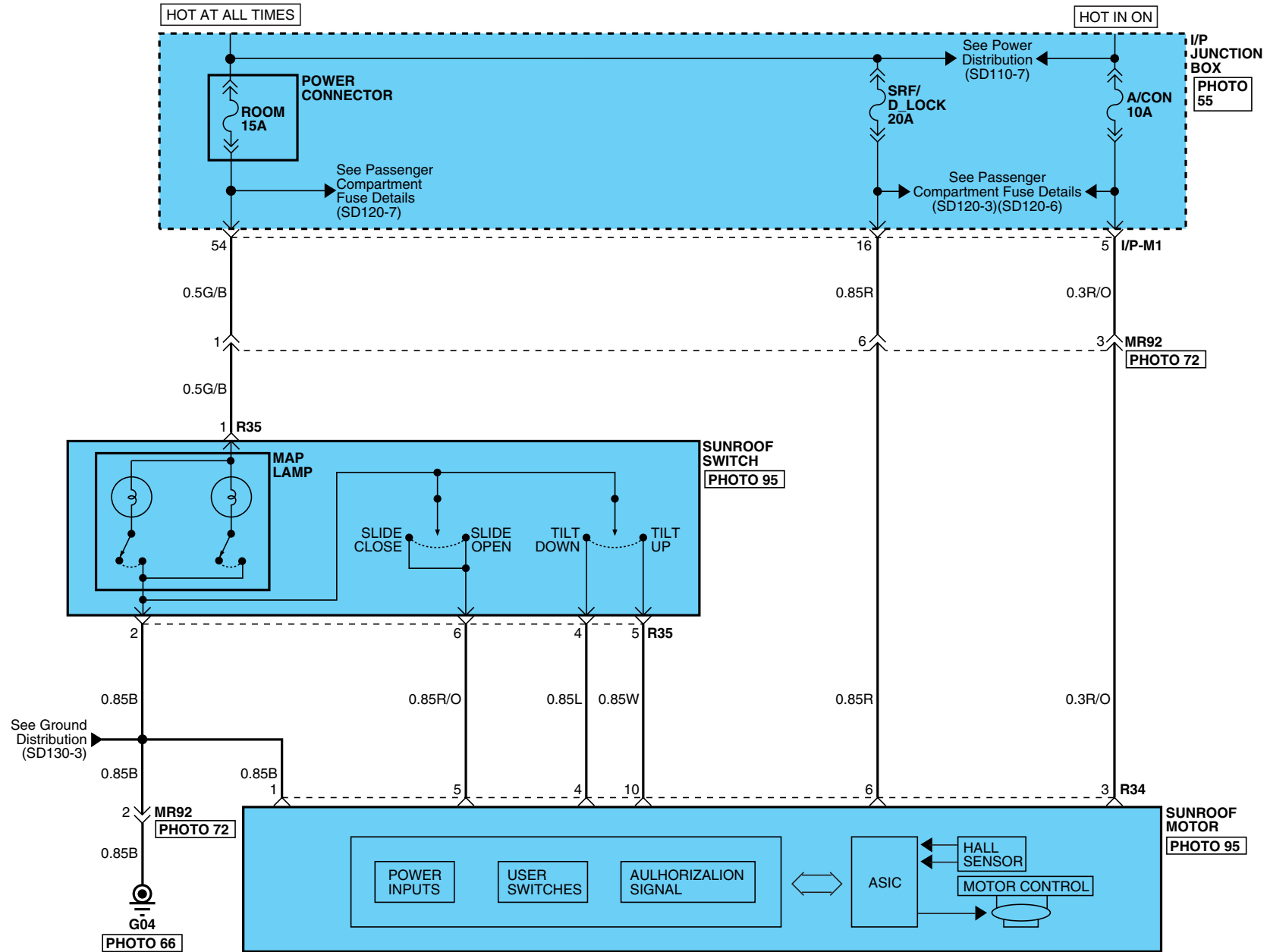

SUNROOF

SUNROOF (2)

SD816-2

R34

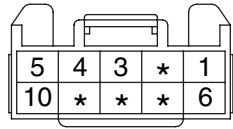

YAZAKI\_REF\_NO.

R35

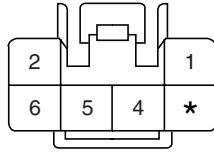

KET\_090II\_06F

BLANK

BLANK



POWER WINDOWS

POWER WINDOWS (2)

SD824-2

With Safety Power Window

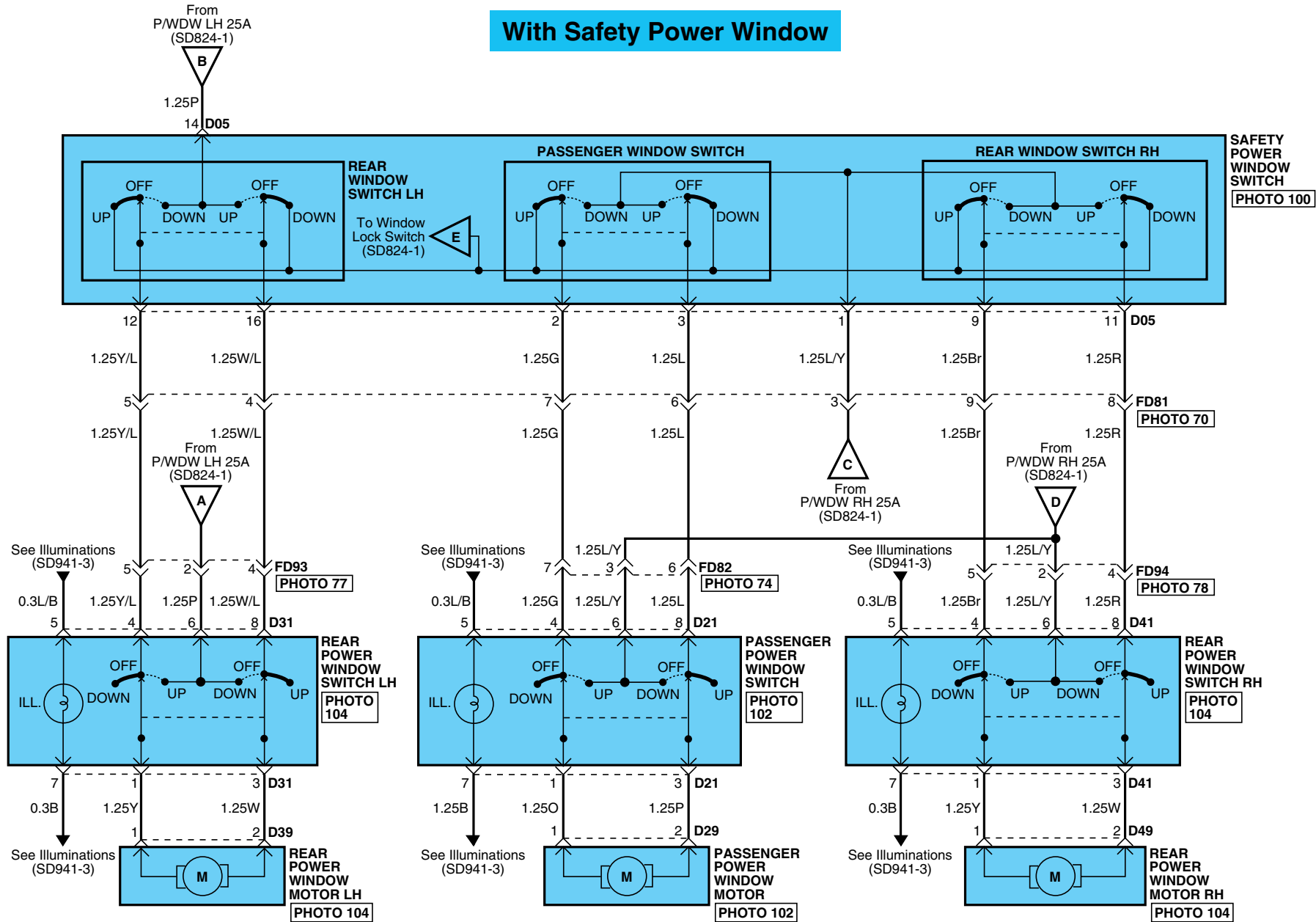

POWER WINDOWS

POWER WINDOWS (3)

SD824-3

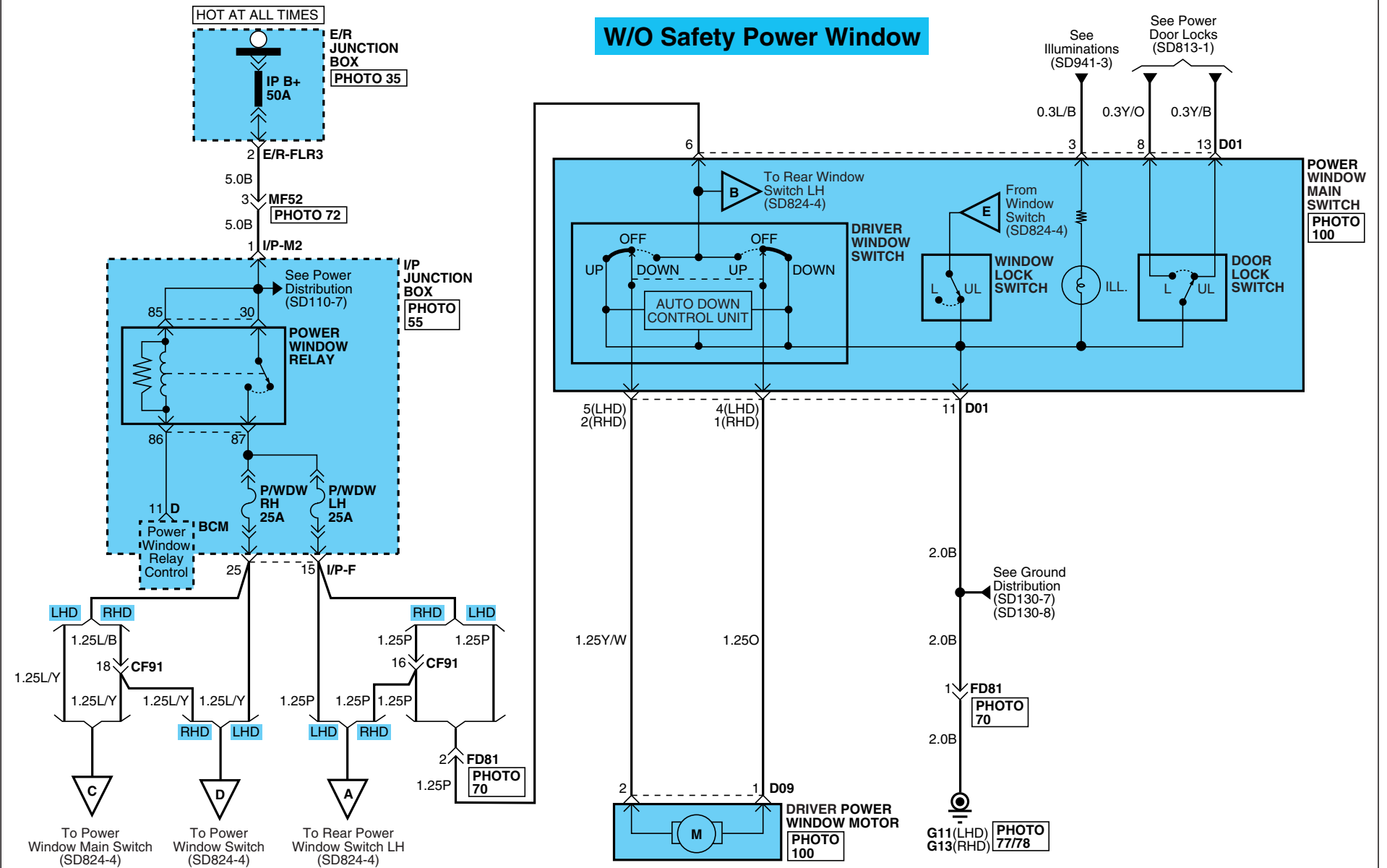



POWER WINDOWS

POWER WINDOWS (4)

SD824-4

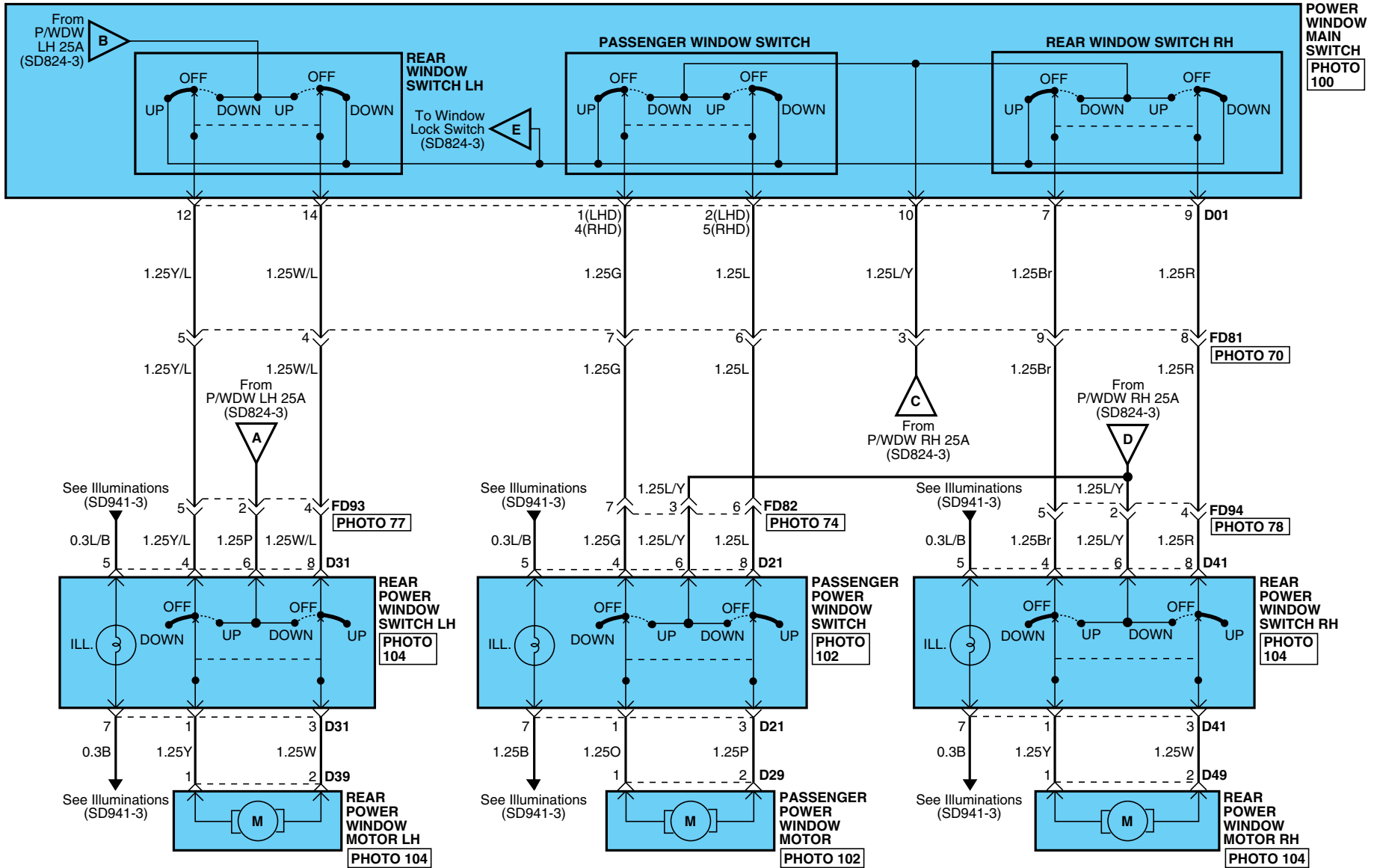

W/O Safety Power Window



POWER WINDOWS

POWER WINDOWS (5)

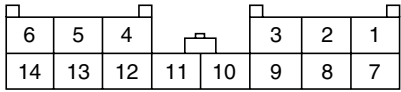
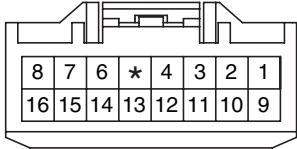
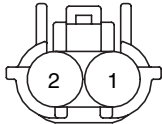
SD824-5

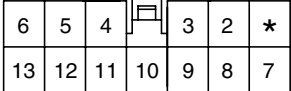
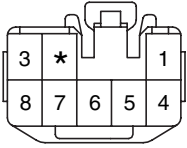
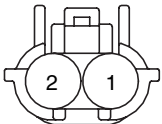
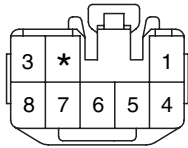
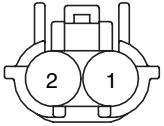
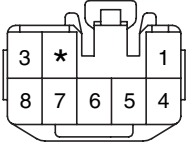
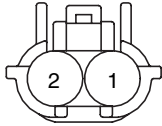
<p style="text-align: center;"><b>D01</b></p>  <p style="text-align: center;">KET_090II_14F_SW</p>	<p style="text-align: center;"><b>D05</b></p>  <p style="text-align: center;">AMP_090III_16F_W</p>	<p style="text-align: center;"><b>D09</b></p>  <p style="text-align: center;">KET_SWP_02F_B</p>	<p style="text-align: center;"><b>D12</b></p>  <p style="text-align: center;">KET_090IWP_06F_B</p>
<p style="text-align: center;"><b>D13</b></p>  <p style="text-align: center;">AMP_MKII_13F</p>	<p style="text-align: center;"><b>D21</b></p>  <p style="text-align: center;">KET_090II_08F_B</p>	<p style="text-align: center;"><b>D29</b></p>  <p style="text-align: center;">KET_SWP_02F_B</p>	<p style="text-align: center;"><b>D31</b></p>  <p style="text-align: center;">KET_090II_08F_B</p>
<p style="text-align: center;"><b>D39</b></p>  <p style="text-align: center;">KET_SWP_02F_B</p>	<p style="text-align: center;"><b>D41</b></p>  <p style="text-align: center;">KET_090II_08F_B</p>	<p style="text-align: center;"><b>D49</b></p>  <p style="text-align: center;">KET_SWP_02F_B</p>	<p style="text-align: center;"><b>BLANK</b></p>

**POWER WINDOWS**

**POWER WINDOWS (6)**

**SD824-6**

**MEMO**

ELECTRO CHROMIC MIRROR E12D98AE

ELECTRO CHROMIC MIRROR (1)

SD851-1

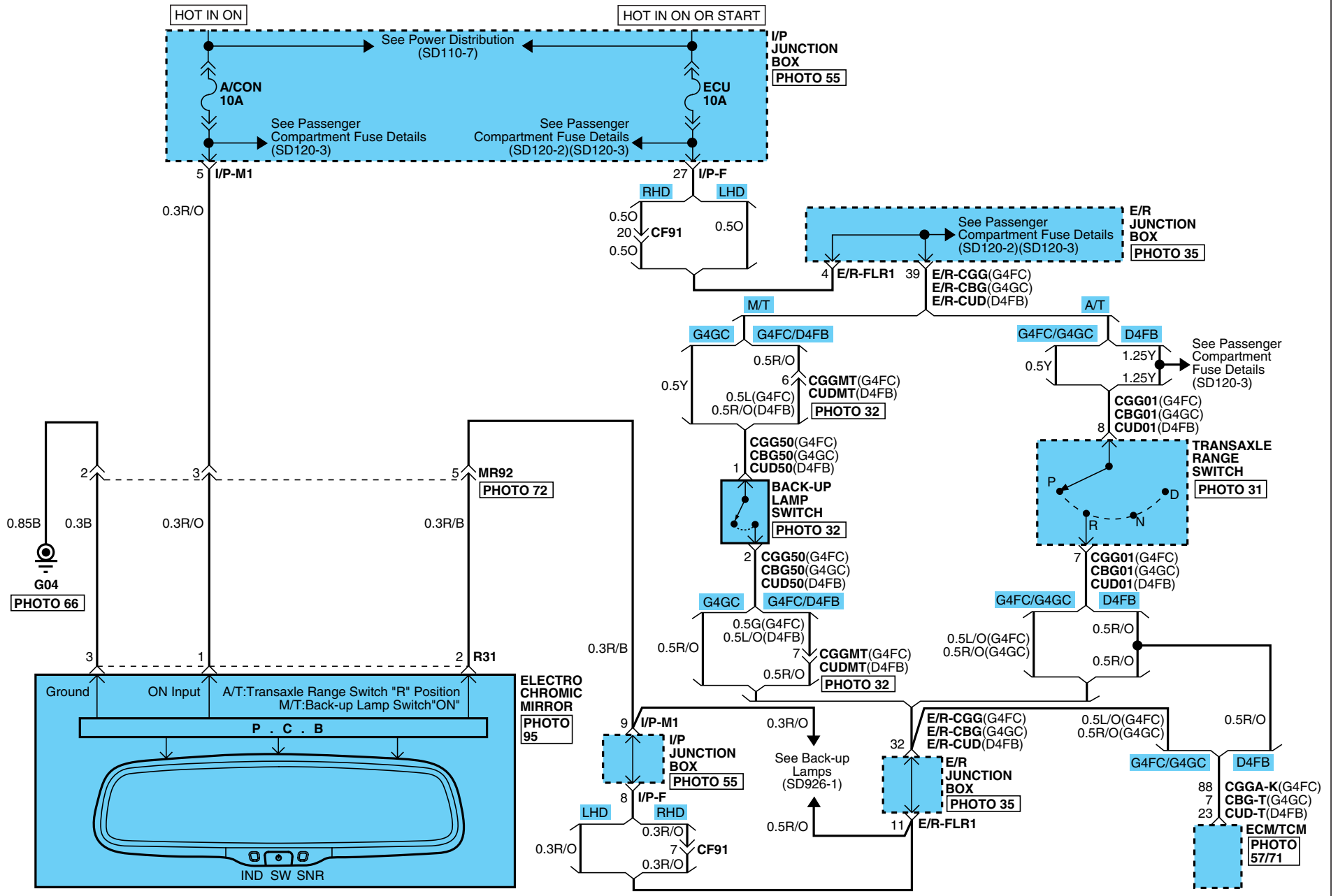

ELECTRO CHROMIC MIRROR

ELECTRO CHROMIC MIRROR (2)

SD851-2

CGGA-K

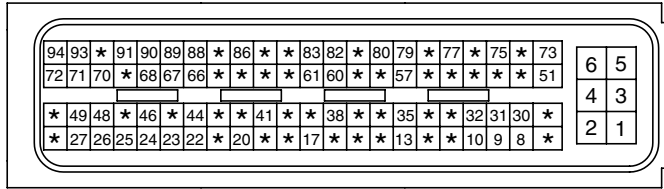

AMP\_ECU\_94F\_B

CBG-T

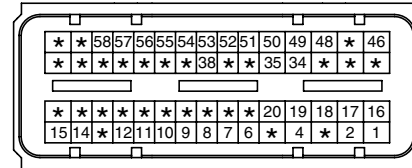

AMP\_ECU\_60F\_B

BLANK

CUD-T

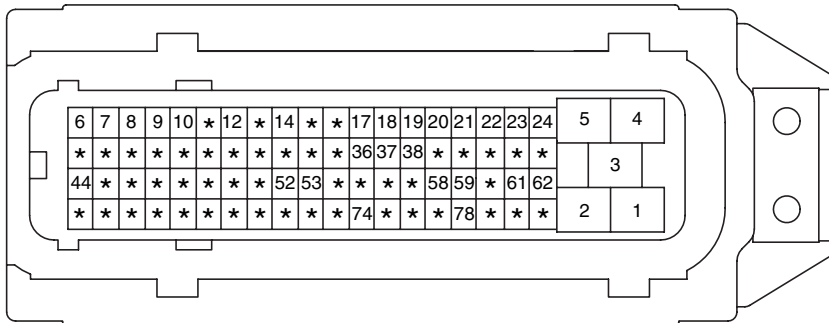

KET\_ECU\_81F\_B

CGG01

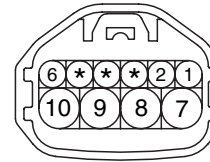

KET\_SSD\_10F\_B

CGG50

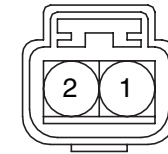

KUM\_NMWP\_02F\_Gr

CBG01



KET\_SSD\_10F\_B

CBG50

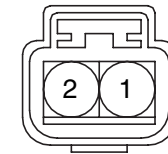

KUM\_NMWP\_02F\_B

CUD01



KET\_SSD\_10F\_B

CUD50

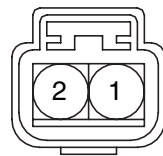

KUM\_NMWP\_02F\_Gr

R31

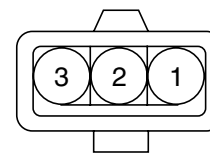

KET\_TLCWP\_03F\_B

BLANK

POWER OUTSIDE MIRRORS ECDEB35C

POWER OUTSIDE MIRRORS (1)

SD876-1

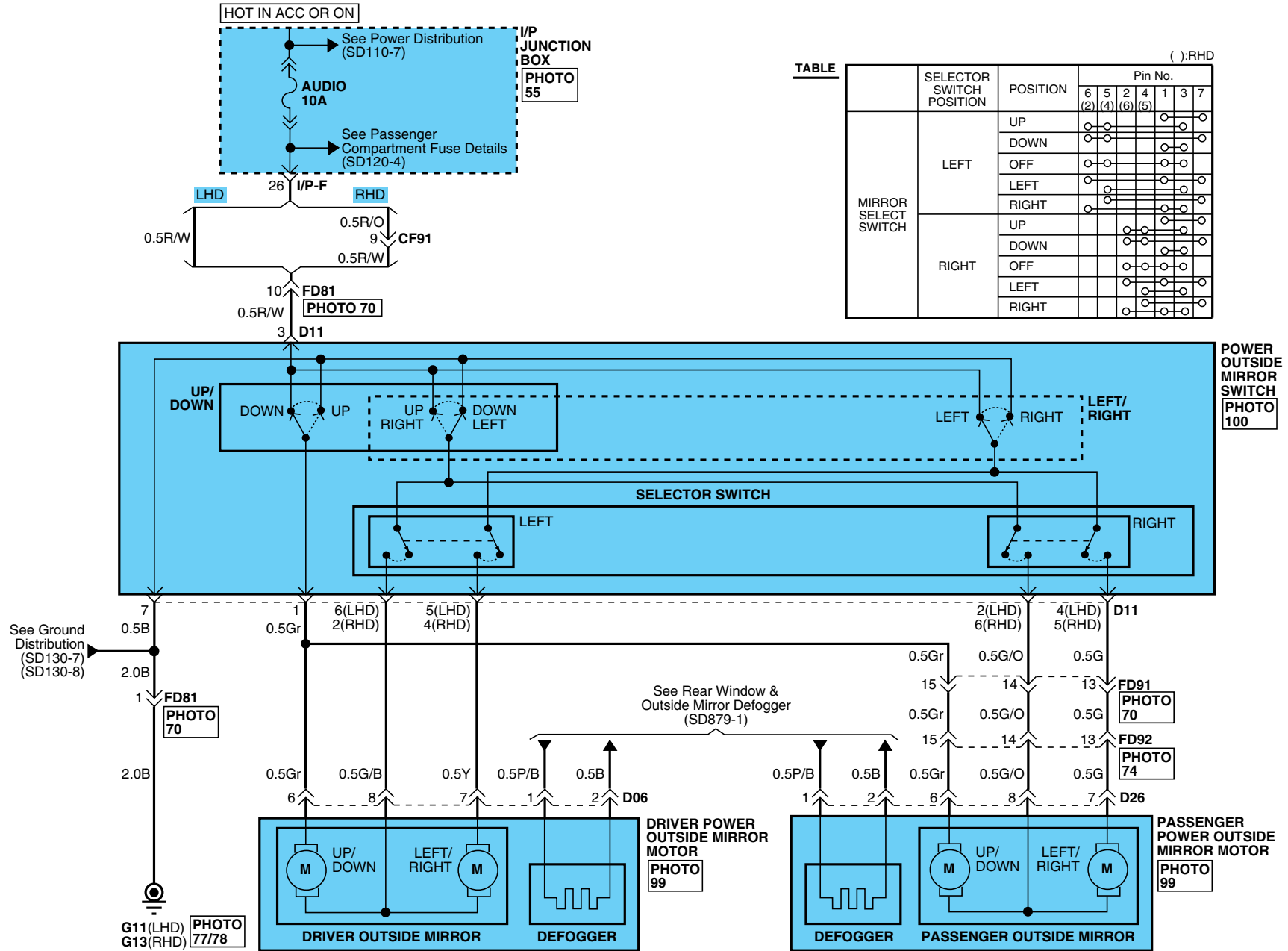

POWER OUTSIDE MIRRORS

POWER OUTSIDE MIRRORS (2)

SD876-2

D06

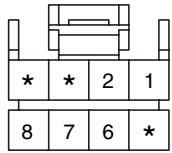

AMP\_040M1\_08F\_B

D11

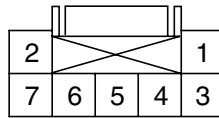

KUM\_CDR\_07F

D26

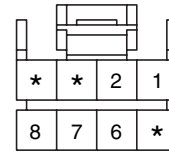

AMP\_040M1\_08F\_B

BLANK

REAR WINDOW & OUTSIDE MIRROR DEFOGGER ECCEEC4A

REAR WINDOW & OUTSIDE MIRROR DEFOGGER (1)

SD879-1

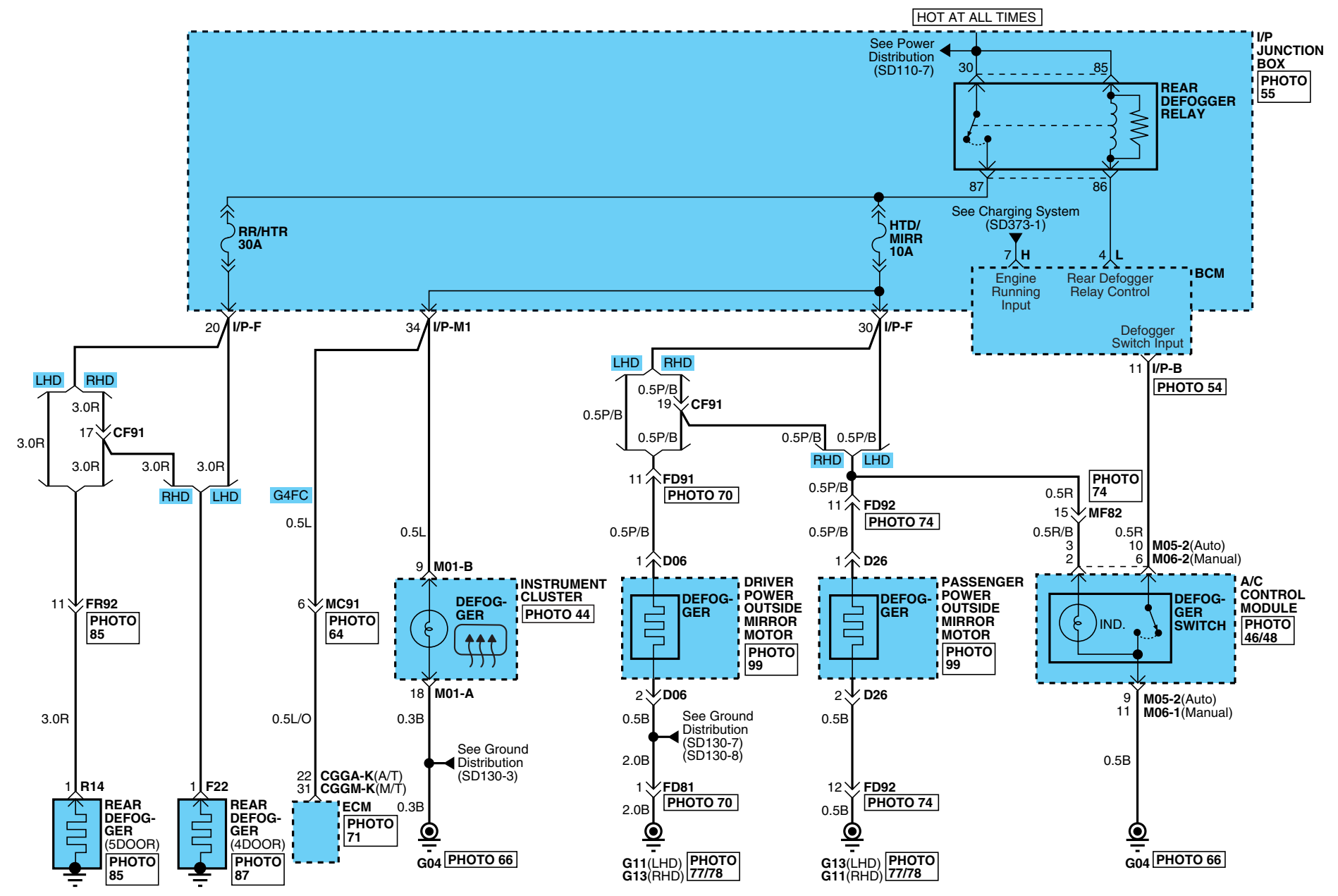



REAR WINDOW & OUTSIDE MIRROR DEFOGGER

REAR WINDOW & OUTSIDE MIRROR DEFOGGER (2)

SD879-2

CGGA-K

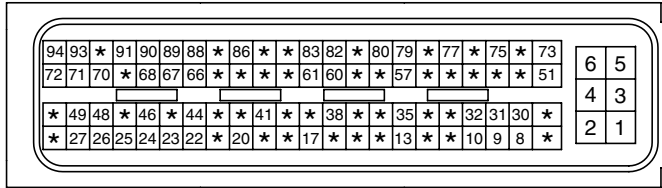

AMP\_ECU\_94F\_B

CGGM-K

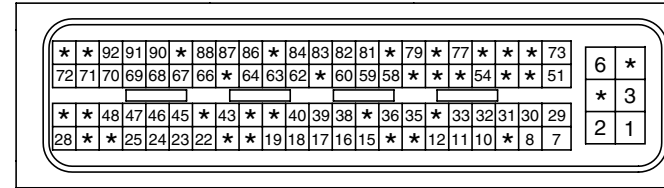

AMP\_ECU\_94F\_B

D06

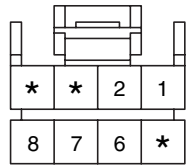

AMP\_040M1\_08F\_B

D26

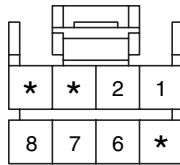

AMP\_040M1\_08F\_B

F22



AMP\_250DL\_01F\_B

I/P-B

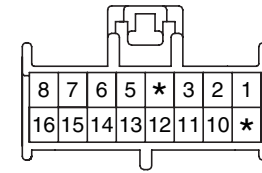

PKD\_ASM\_16F\_GR

M01-A

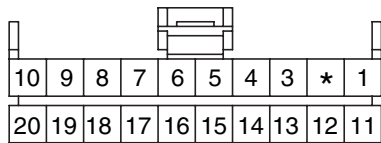

AMP\_040\_MK1\_20F

M01-B

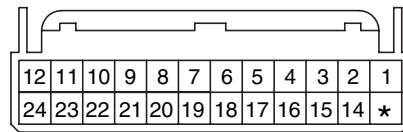

AMP\_025\_I/O\_24F

M05-2

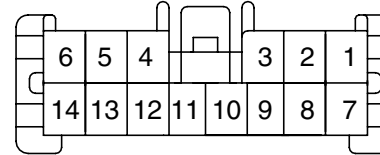

KET\_SDLII\_14F

M06-1

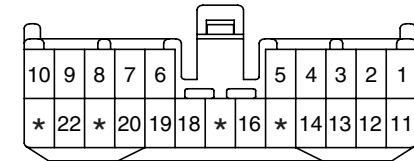

KET\_050\_23F\_W

M06-2

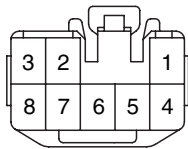

KET\_090II\_08F\_W

R14



AMP\_250DL\_01F\_B

BLANK

BLANK

SEAT WARMER EOC9FDC5

SEAT WARMER (1)

SD889-1

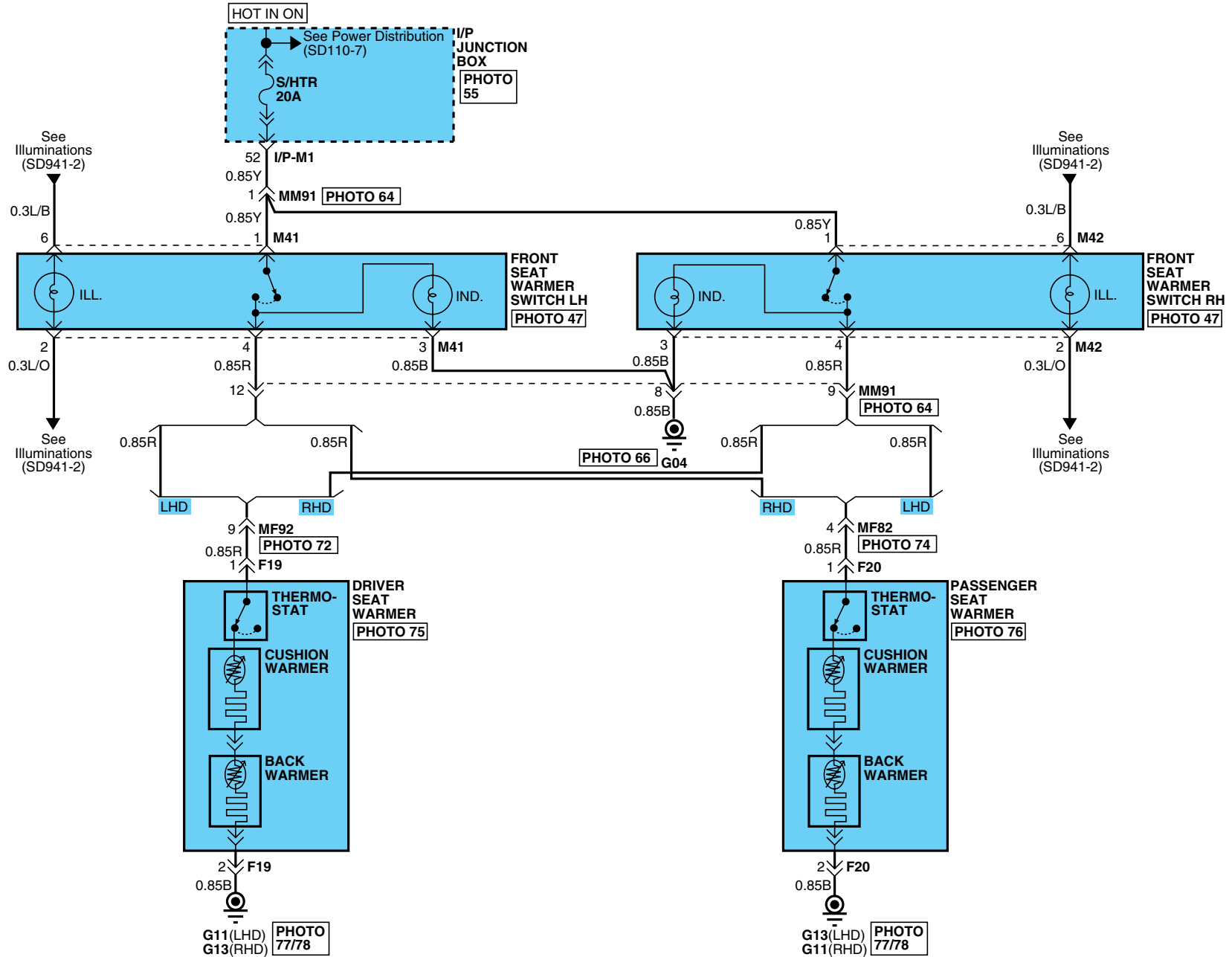

SEAT WARMER

SEAT WARMER (2)

SD889-2

F19

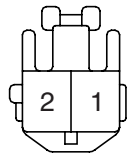

KET\_090II\_02F

F20

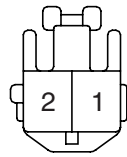

KET\_090II\_02F

M41

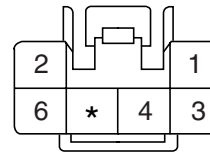

KET\_090II\_06F\_B

M42

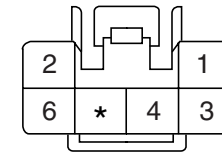

KET\_090II\_06F\_L

HEAD LAMPS EFA7E603

HEAD LAMPS (1)

SD921-1

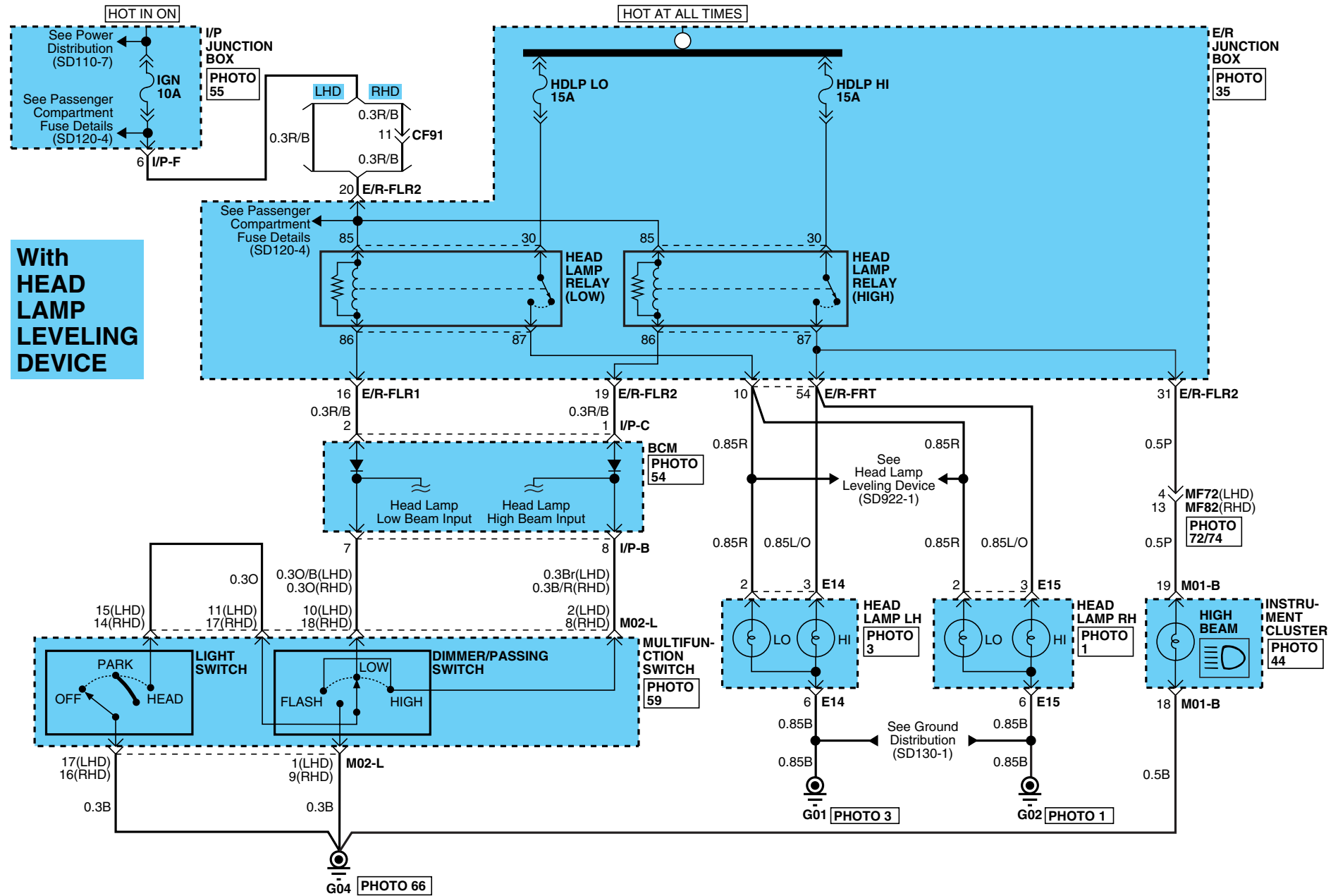

With HEAD LAMP LEVELING DEVICE

# HEAD LAMPS

## HEAD LAMPS (2)

SD921-2

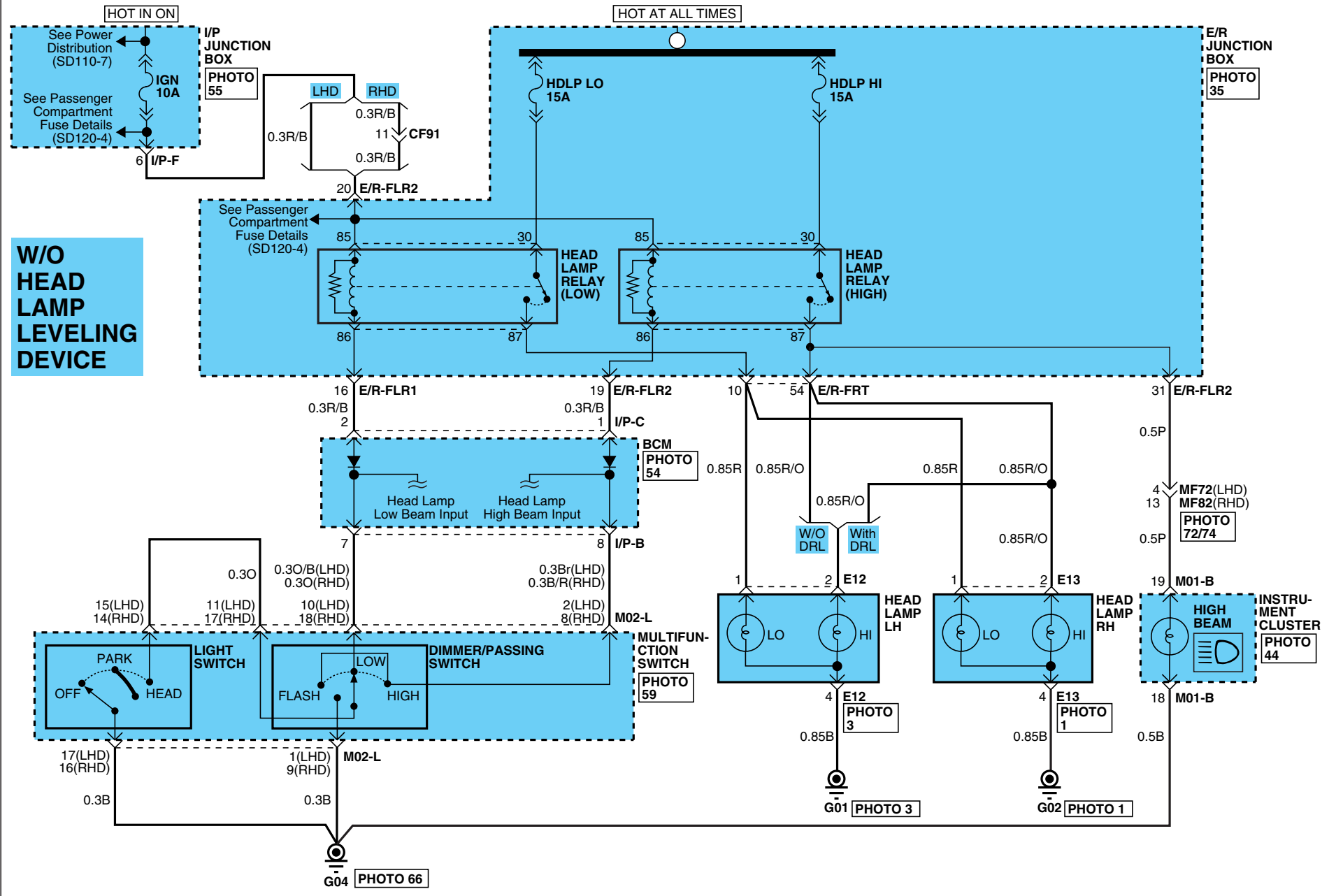

HEAD LAMPS

HEAD LAMPS (3)

SD921-3

E12

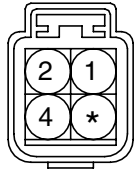

KUM\_NMWP\_04F\_B

E13

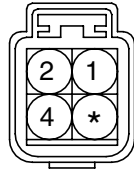

KUM\_NMWP\_04F\_B

E14

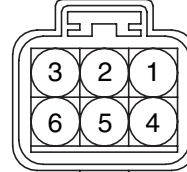

KUM\_NMWP\_06F\_B

E15

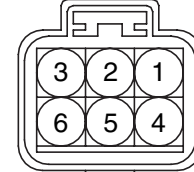

KUM\_NMWP\_06F\_B

I/P-B

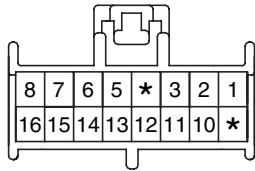

PKD\_ASM\_16F\_GR

I/P-C

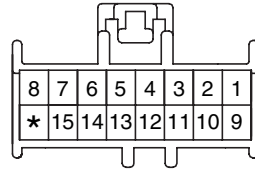

PKD\_ASM\_16F\_BR

M01-B

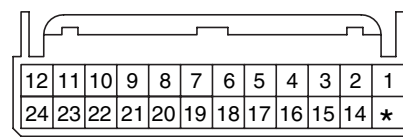

AMP\_025\_I/O\_24F

M02-L

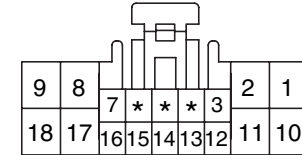

KET\_0509\_18F

**HEAD LAMPS**

**HEAD LAMPS (4)**

**SD921-4**

**MEMO**

HEAD LAMP LEVELING DEVICE E6BD7E0E

SD922-1

HEAD LAMP LEVELING DEVICE (1)

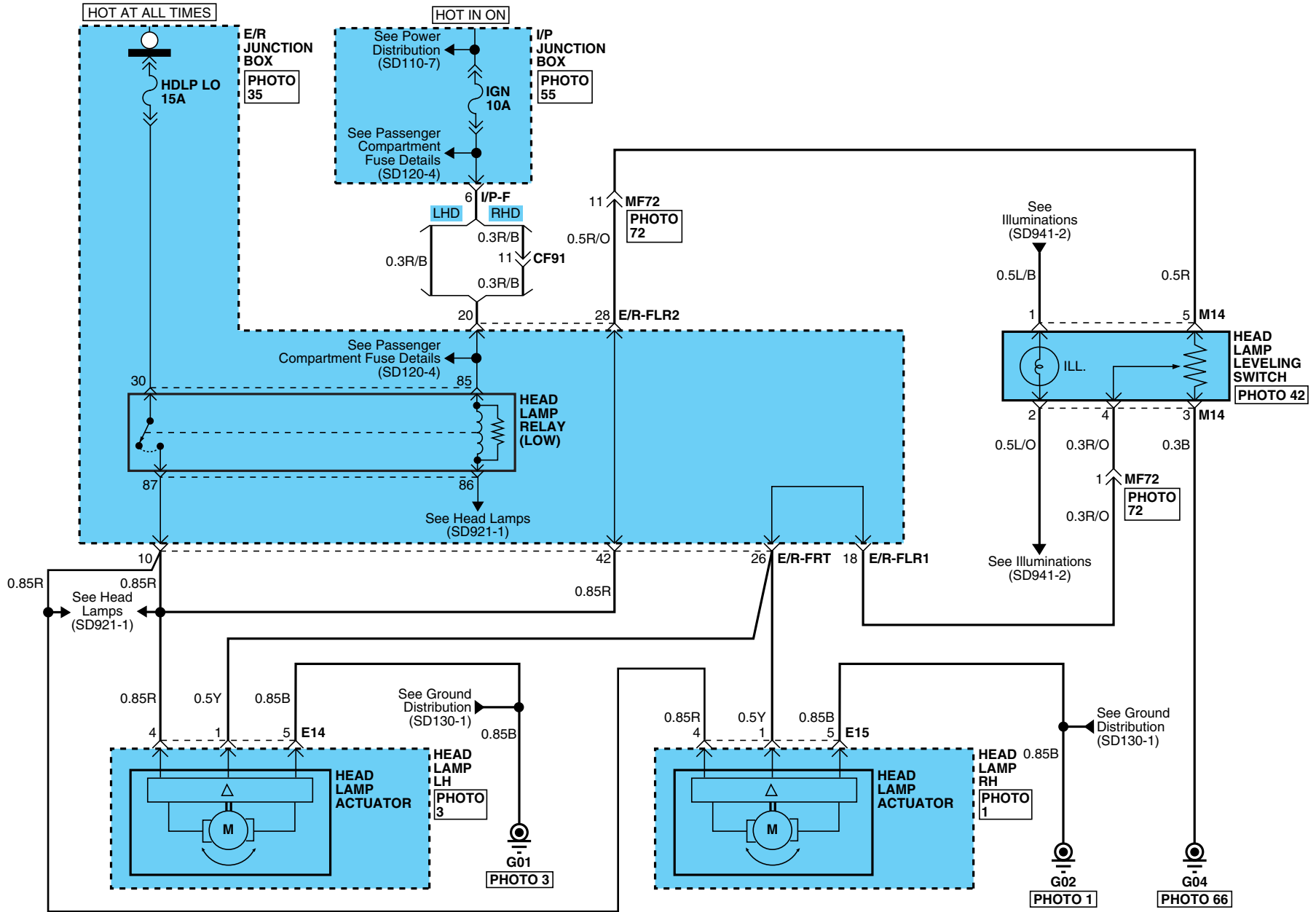



# HEAD LAMP LEVELING DEVICE

## HEAD LAMP LEVELING DEVICE (2)

SD922-2

E14

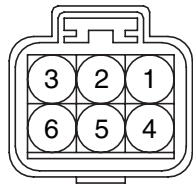

KUM\_NMWP\_06F\_B

E15

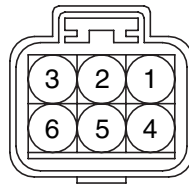

KUM\_NMWP\_06F\_B

M14

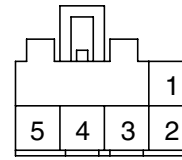

KUM\_CDR\_05F

BLANK

FOG LAMPS (1)

SD924-1

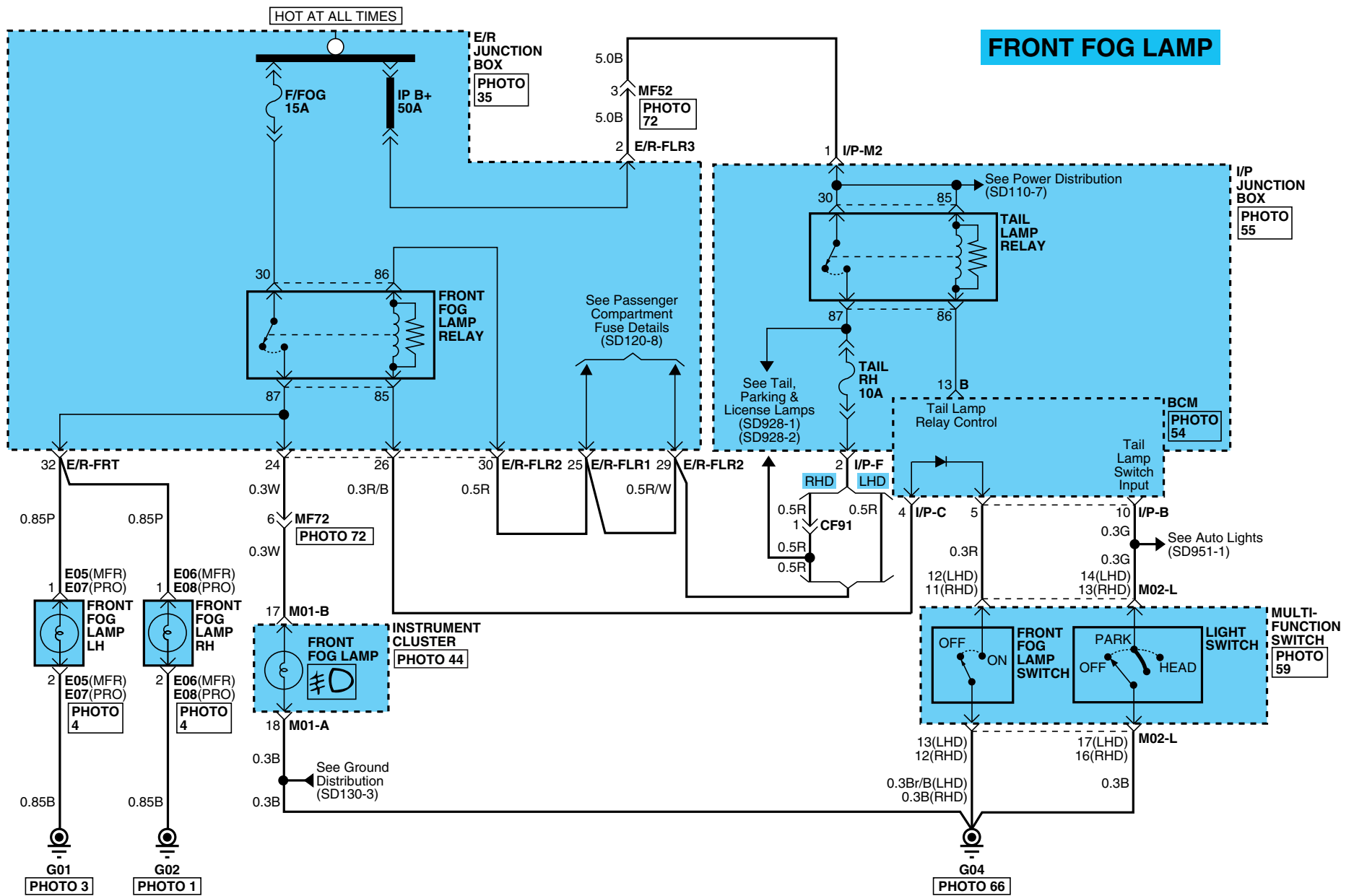

FOG LAMPS



FOG LAMPS (2)

SD924-2

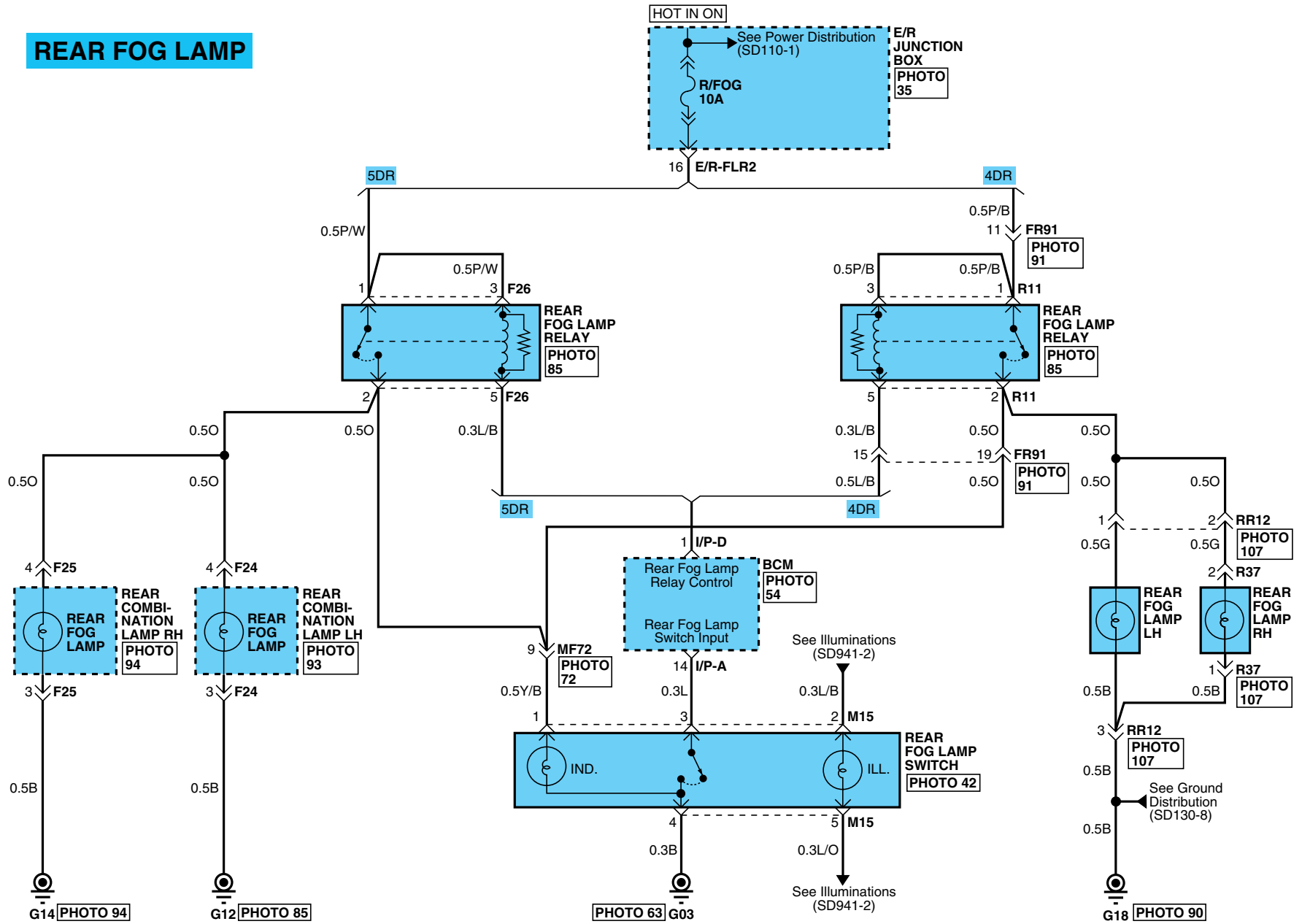
REAR FOG LAMP

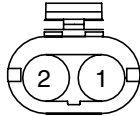
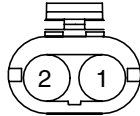
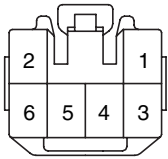
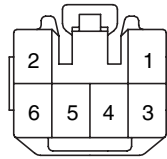
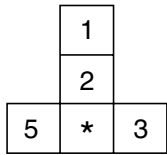
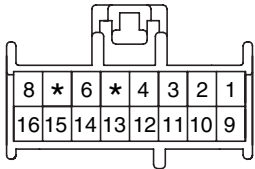
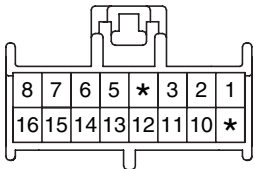
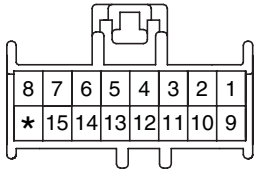
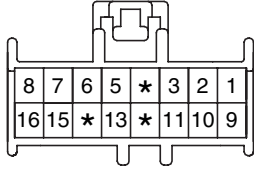
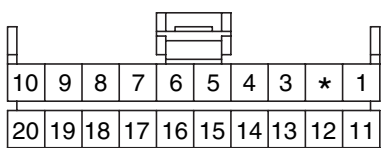
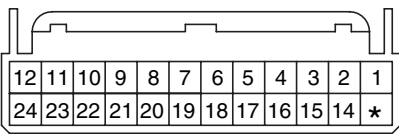
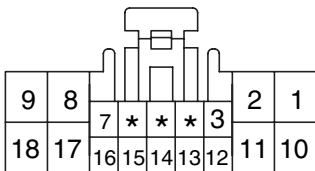
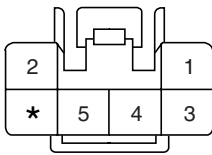
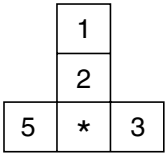
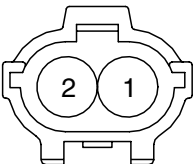

FOG LAMPS

FOG LAMPS (3)			SD924-3
<p><b>E05</b></p>  <p>KET_110WP_02F_B</p>	<p><b>E06</b></p>  <p>KET_110WP_02F_B</p>	<p><b>E07</b></p>  <p>PACKARD</p>	<p><b>E08</b></p>  <p>PACKARD</p>
<p><b>F24</b></p>  <p>KET_090II_06F</p>	<p><b>F25</b></p>  <p>KET_090II_06F</p>	<p><b>F26</b></p>  <p>KET_RELAY_CONN_N</p>	<p><b>I/P-A</b></p>  <p>PKD_ASM_16F_B</p>
<p><b>I/P-B</b></p>  <p>PKD_ASM_16F_GR</p>	<p><b>I/P-C</b></p>  <p>PKD_ASM_16F_BR</p>	<p><b>I/P-D</b></p>  <p>PKD_ASM_16F_G</p>	<p><b>M01-A</b></p>  <p>AMP_040_MK1_20F</p>
<p><b>M01-B</b></p>  <p>AMP_025_I/O_24F</p>	<p><b>M02-L</b></p>  <p>KET_0509_18F</p>	<p><b>M15</b></p>  <p>KET_090II_06F_B</p>	<p><b>R11</b></p>  <p>KET_RELAY_CONN_N</p>
<p><b>R37</b></p>  <p>CR02F185</p>	<p><b>BLANK</b></p>	<p><b>BLANK</b></p>	<p><b>BLANK</b></p>

**FOG LAMPS**

**FOG LAMPS (4)**

**SD924-4**

**MEMO**

TURN & HAZARD LAMPS (1)

SD925-1

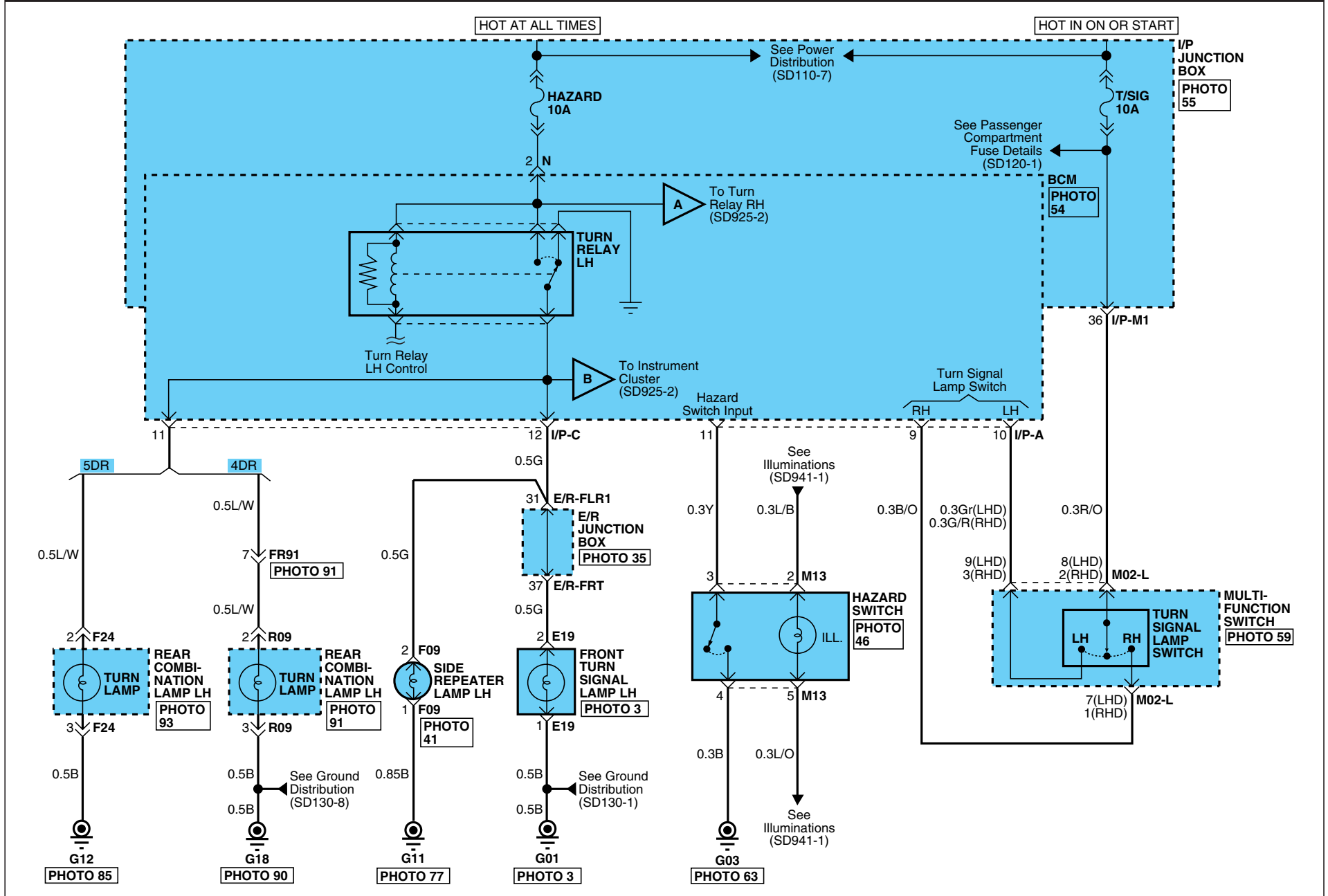

# TURN & HAZARD LAMPS

## TURN & HAZARD LAMPS (2)

SD925-2

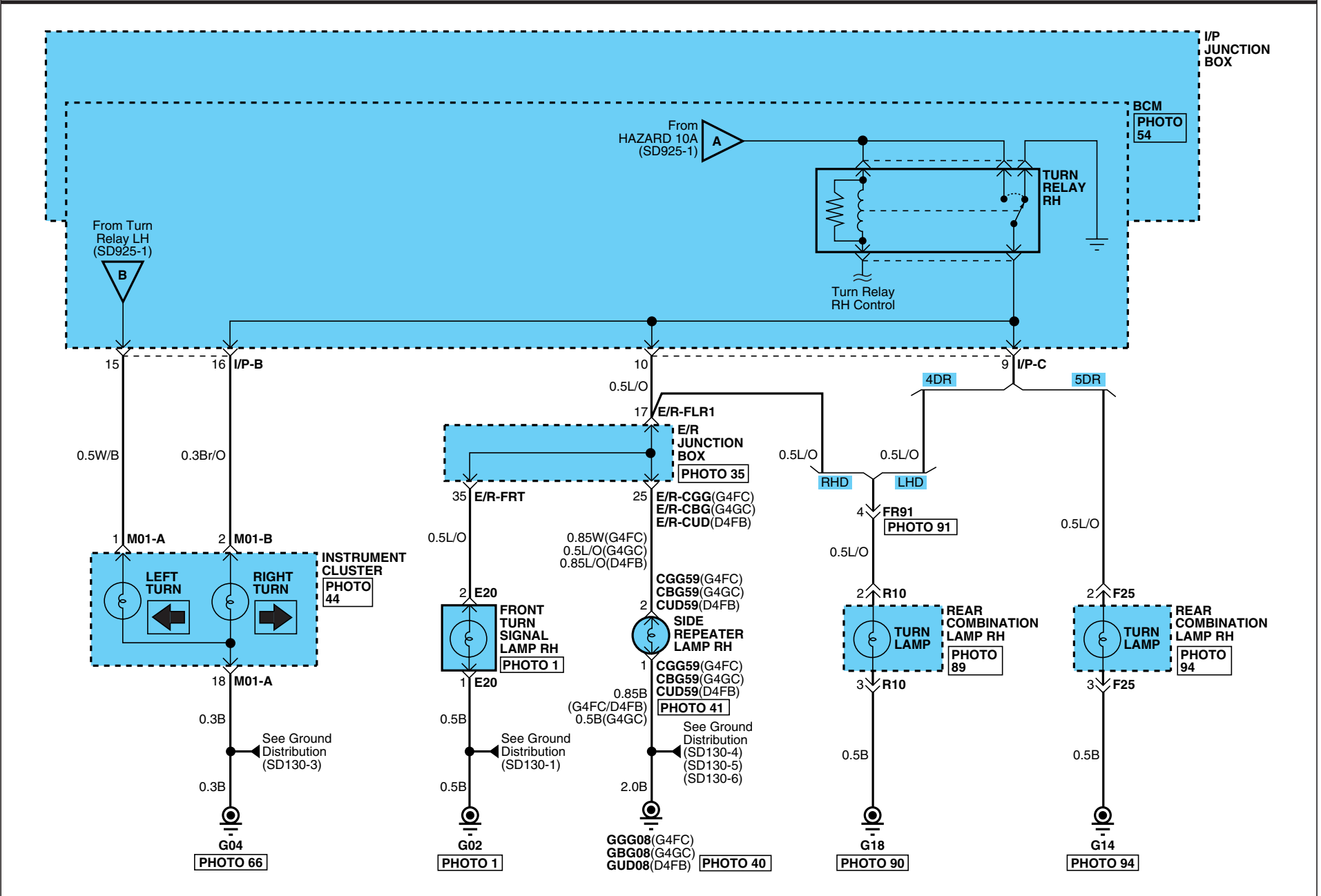

TURN & HAZARD LAMPS

TURN & HAZARD LAMPS (3)

SD925-3

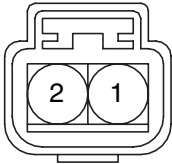
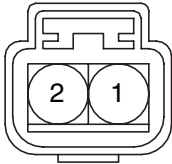
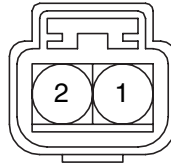
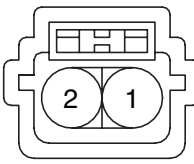
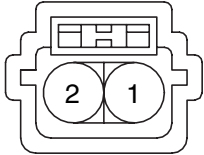
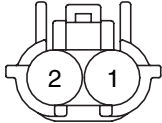
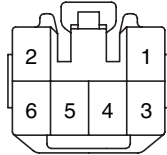
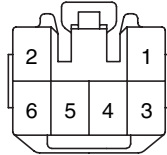
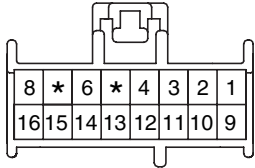
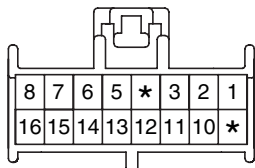
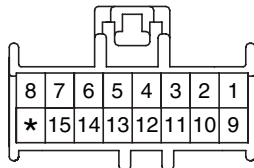
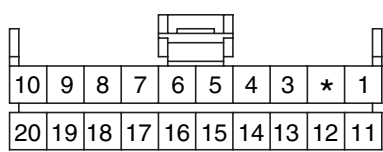
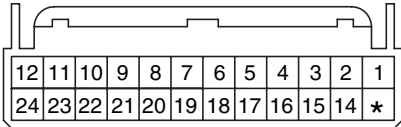
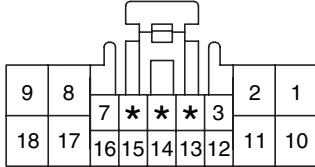
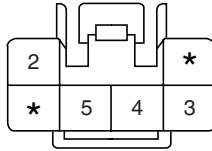
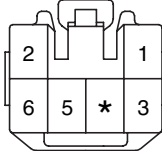
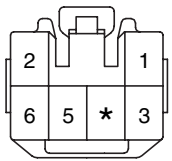
<p><b>CGG59</b></p>  <p>KUM_NMWP_02F_B</p>	<p><b>CBG59</b></p>  <p>KUM_NMWP_02F_B</p>	<p><b>CUD59</b></p>  <p>KUM_NMWP_02F_B</p>	<p><b>E19</b></p>  <p>KUM_NDWP_02F_GY</p>
<p><b>E20</b></p>  <p>KUM_NDWP_02F_GY</p>	<p><b>F09</b></p>  <p>KUM_NMWP_02F_B</p>	<p><b>F24</b></p>  <p>KET_090II_06F</p>	<p><b>F25</b></p>  <p>KET_090II_06F</p>
<p><b>I/P-A</b></p>  <p>PKD_ASM_16F_B</p>	<p><b>I/P-B</b></p>  <p>PKD_ASM_16F_GR</p>	<p><b>I/P-C</b></p>  <p>PKD_ASM_16F_BR</p>	<p><b>M01-A</b></p>  <p>AMP_040_MK1_20F</p>
<p><b>M01-B</b></p>  <p>AMP_025_I/O_24F</p>	<p><b>M02-L</b></p>  <p>KET_0509_18F</p>	<p><b>M13</b></p>  <p>KET_090II_06F_G</p>	<p><b>R09</b></p>  <p>KET_090II_06F</p>
<p><b>R10</b></p>  <p>KET_090II_06F</p>	<p><b>BLANK</b></p>	<p><b>BLANK</b></p>	<p><b>BLANK</b></p>



**TURN & HAZARD LAMPS**

**TURN & HAZARD LAMPS (4)**

**SD925-4**

**MEMO**

BACK-UP LAMPS EFE22F76

BACK-UP LAMPS (1)

SD926-1

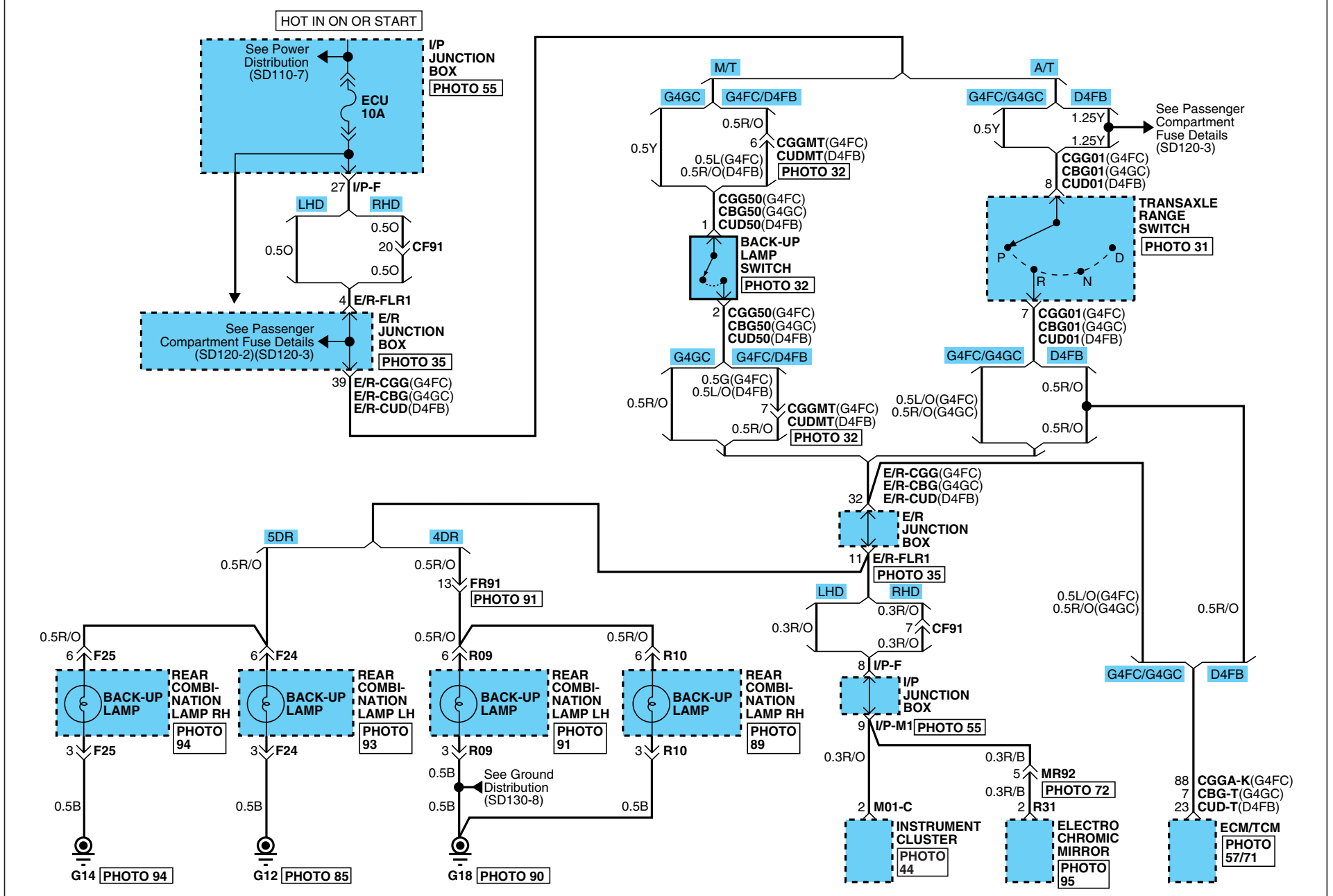

BACK-UP LAMPS

BACK-UP LAMPS (2)

SD926-2

CGGA-K

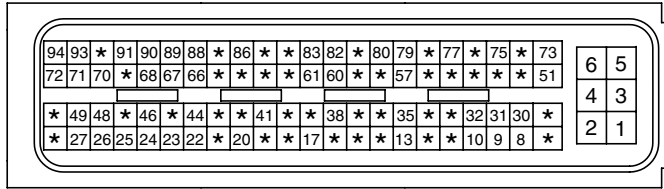

AMP\_ECU\_94F\_B

CBG-T

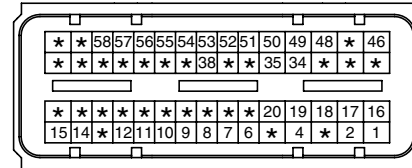

AMP\_ECU\_60F\_B

CGG01



KET\_SSD\_10F\_B

CUD-T

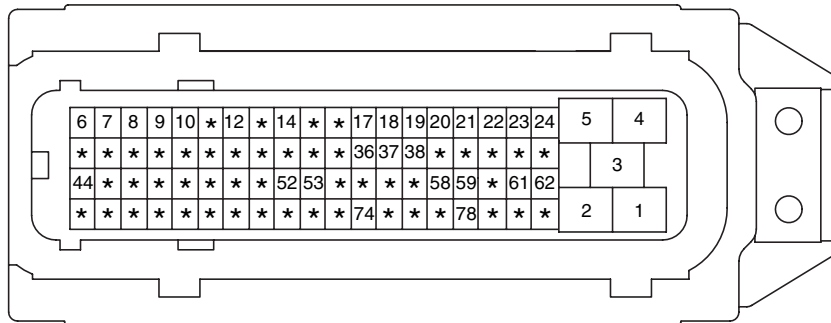

KET\_ECU\_81F\_B

CGG50

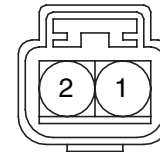

KUM\_NMWP\_02F\_Gr

CBG01



KET\_SSD\_10F\_B

CBG50

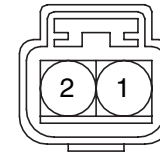

KUM\_NMWP\_02F\_B

CUD01



KET\_SSD\_10F\_B

CUD50

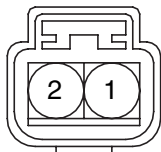

KUM\_NMWP\_02F\_Gr

F24

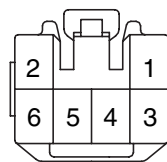

KET\_090II\_06F

F25

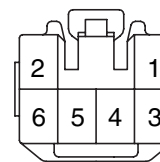

KET\_090II\_06F

M01-C

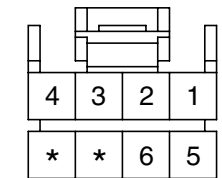

AMP\_040\_MK\_08F

R09

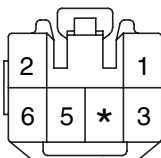

KET\_090II\_06F

R10

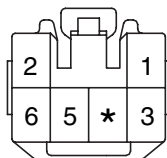

KET\_090II\_06F

R31

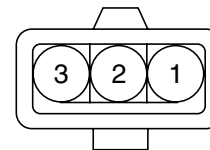

KET\_TLCWP\_03F\_B

BLANK

# STOP LAMPS

E8D1C3AE

## STOP LAMPS (1)

SD927-1

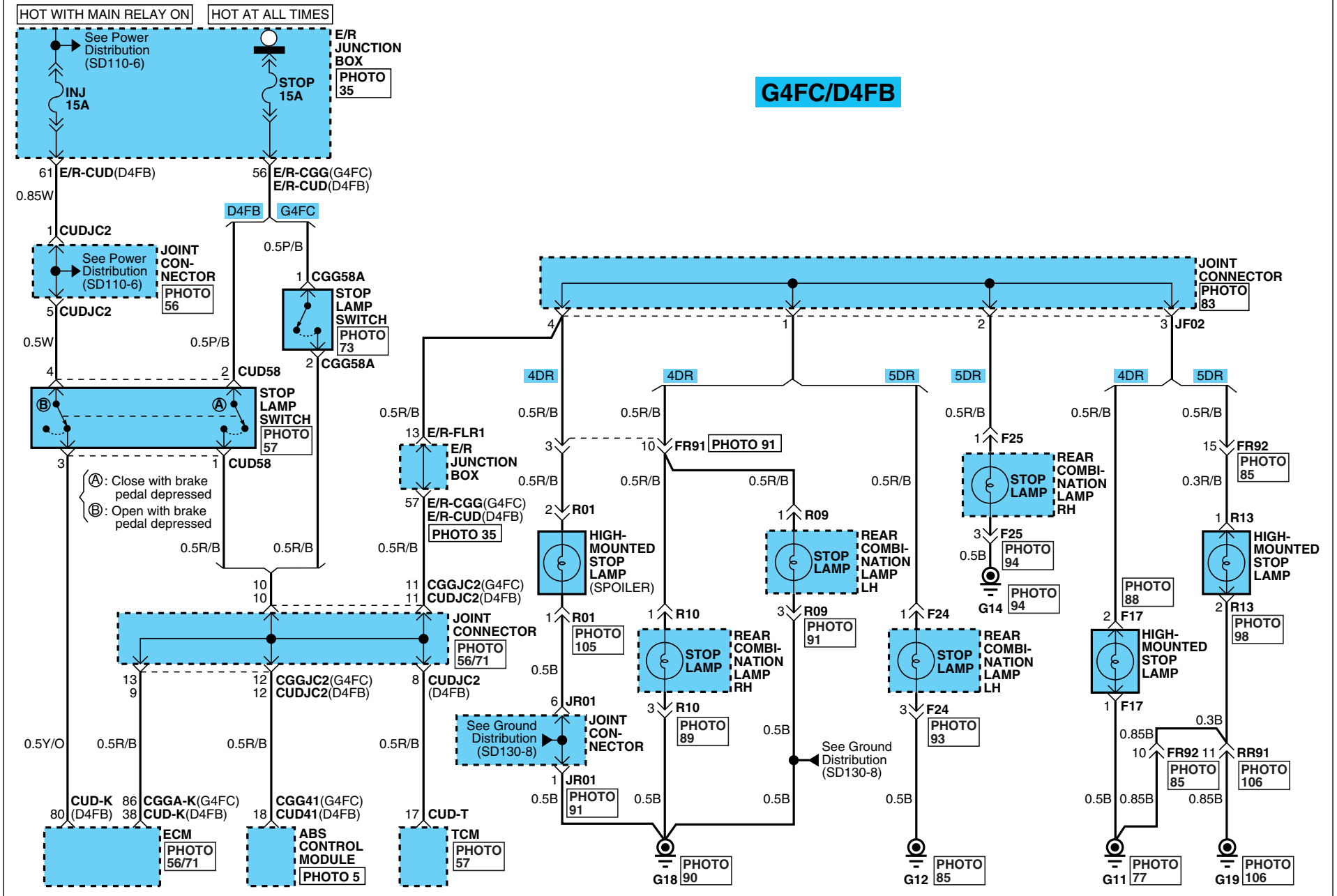

**STOP LAMPS**

**STOP LAMPS (2)**

SD927-2

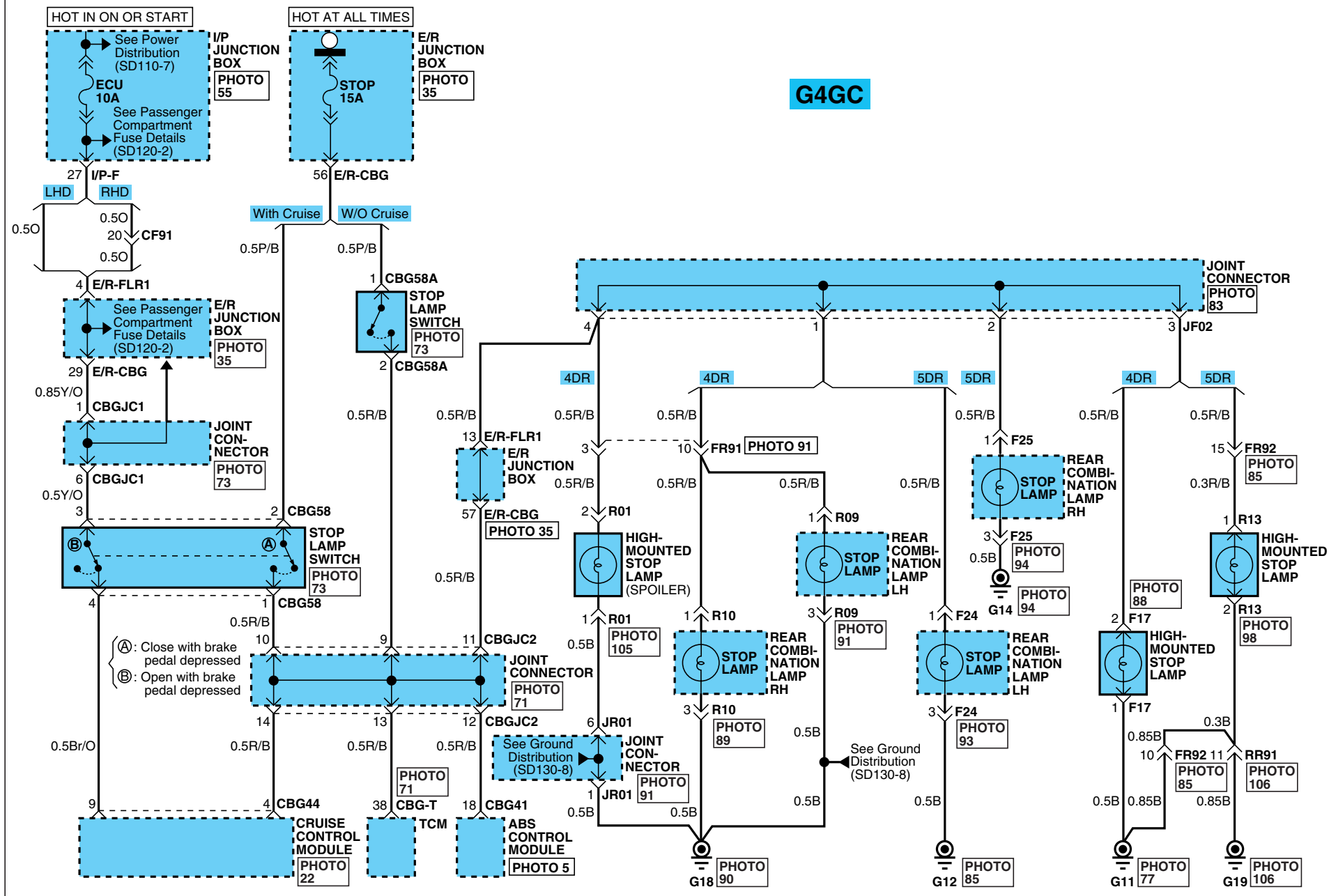

G4GC

STOP LAMPS

STOP LAMPS (3)

SD927-3

CGGA-K

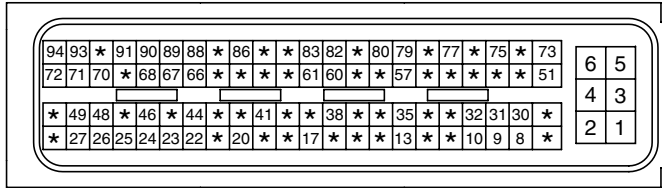

AMP\_ECU\_94F\_B

CBG-T

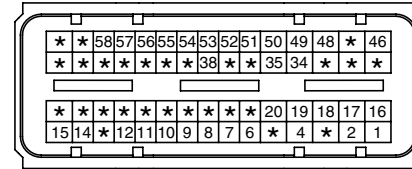

AMP\_ECU\_60F\_B

BLANK

CUD-K

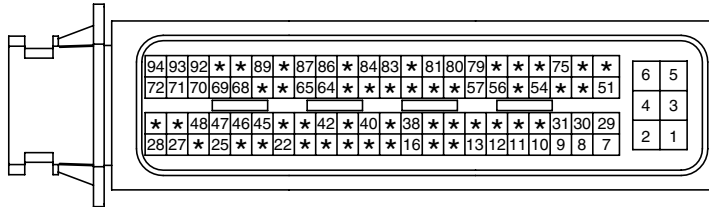

AMP\_ECU\_94F\_B

CUD-T

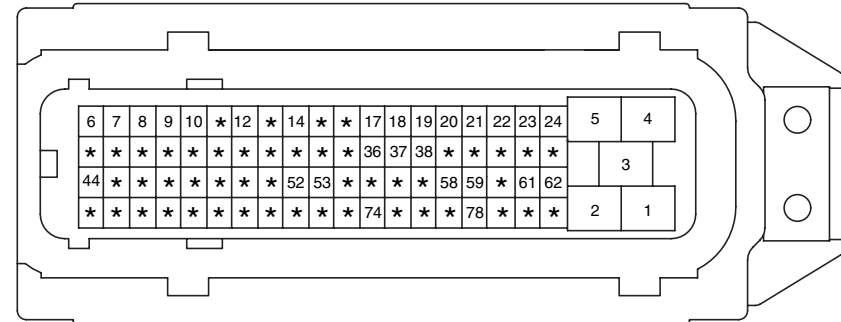

KET\_ECU\_81F\_B

CGG41

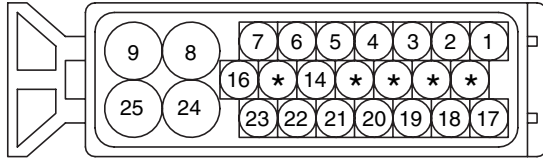

AMP\_ABSWP\_25F\_B\_GER

CGG58A

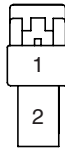

KET\_250DL\_2F\_W

CBG41

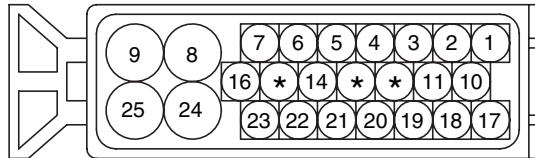

AMP\_ABSWP\_25F\_B

CBG44

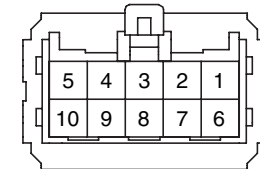

PKD\_150W\_10F\_B

CBG58

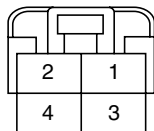

KET\_250DL\_04F

CBG58A

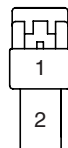

KET\_250DL\_02F\_W

CUD41

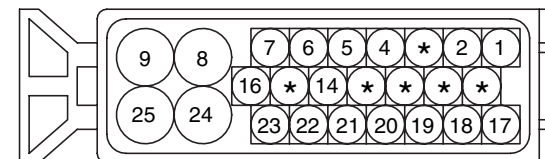

AMP\_ABSWP\_25F\_B\_GER

STOP LAMPS

STOP LAMPS (4)

SD927-4

CUD58

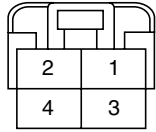

KET\_250DL\_04F\_W

F17

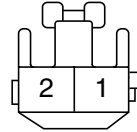

KET\_090II\_02F\_B\_R

F24

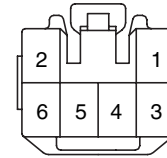

KET\_090II\_06F

F25

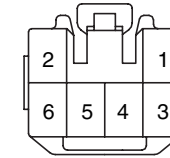

KET\_090II\_06F

R01

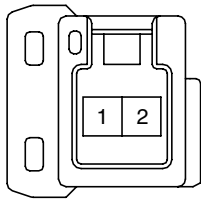

KET\_040III\_02M\_W

R09

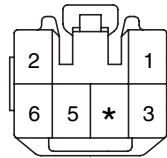

KET\_090II\_06F

R10

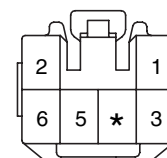

KET\_090II\_06F

R13

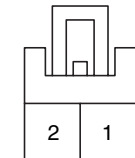

KUM\_CDR\_02F\_B

TAIL, PARKING & LICENSE LAMPS EFF2DBFB

TAIL, PARKING & LICENSE LAMPS (1)

SD928-1

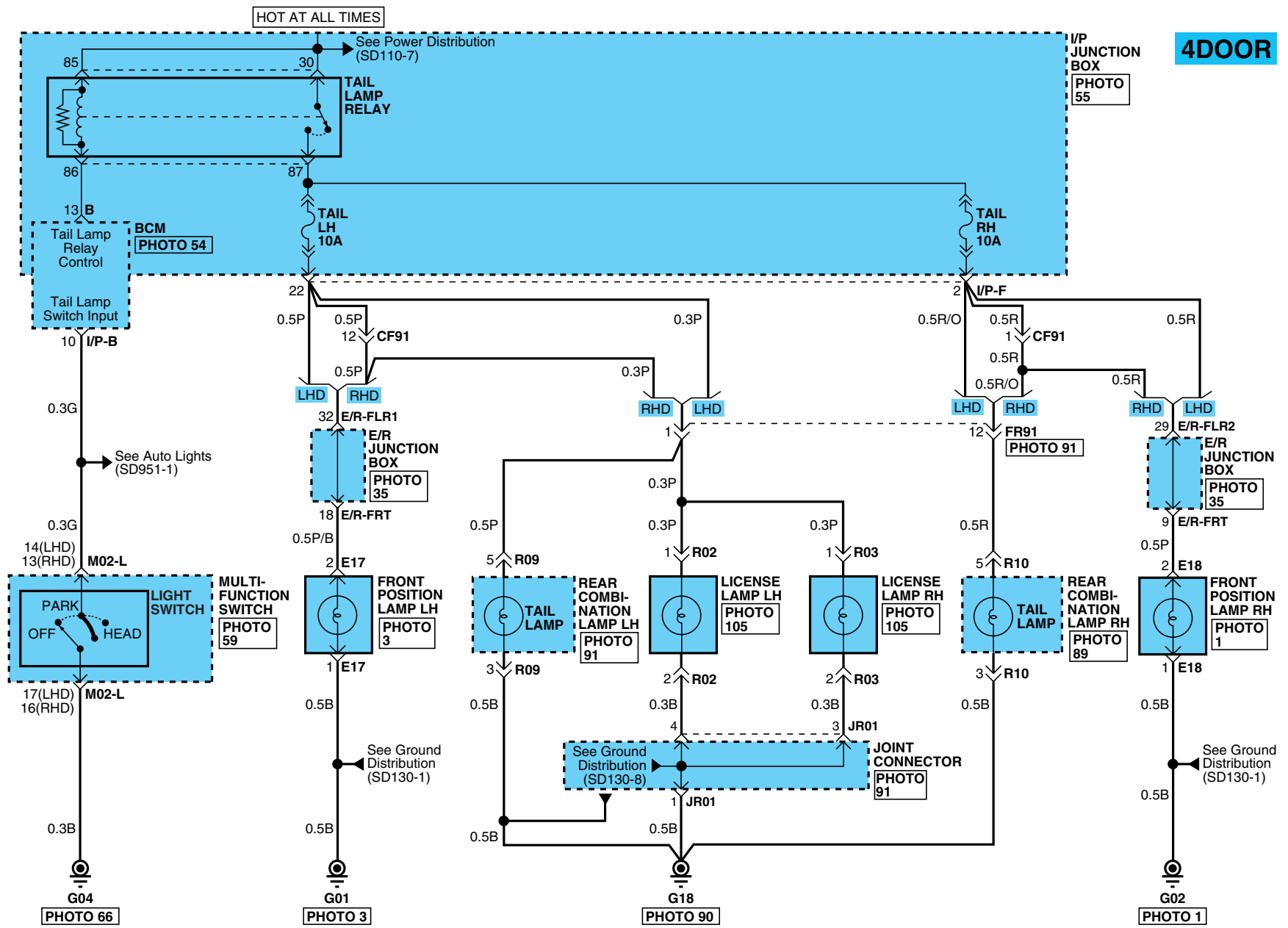



# TAIL, PARKING & LICENSE LAMPS

## TAIL, PARKING & LICENSE LAMPS (2)

SD928-2

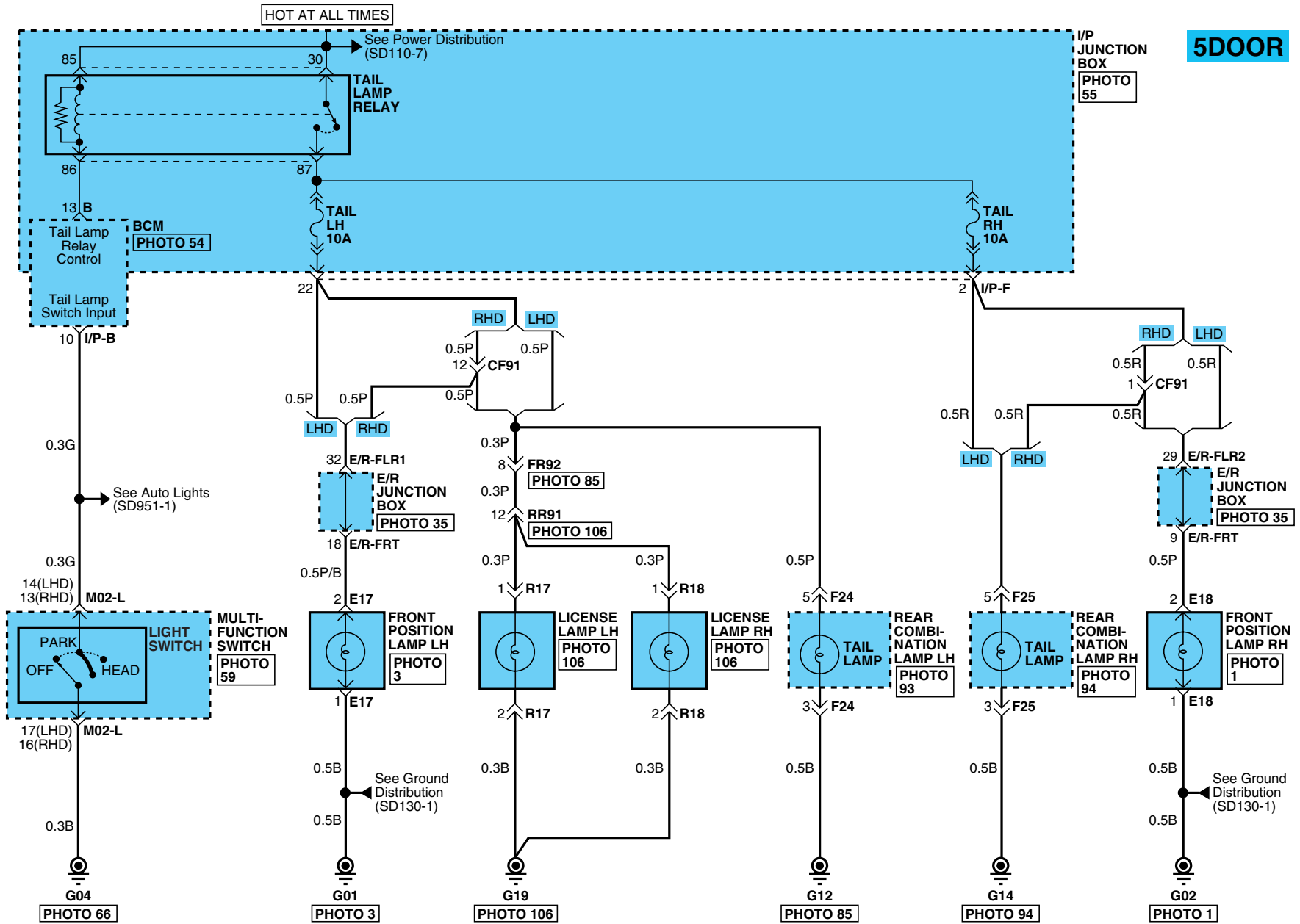

TAIL, PARKING & LICENSE LAMPS

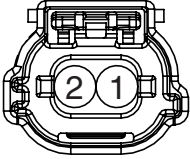
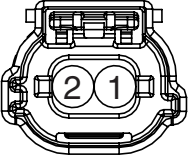
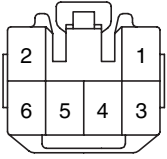
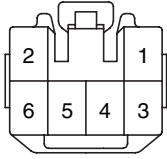
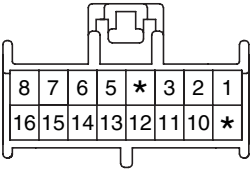
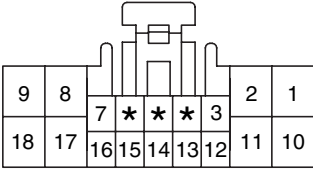
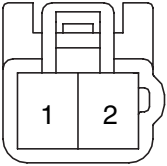
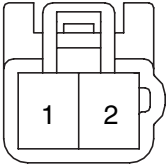
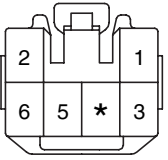
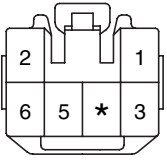
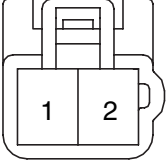
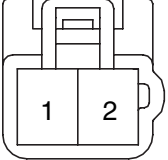
TAIL, PARKING & LICENSE LAMPS (3)			SD928-3
<p><b>E17</b></p>  <p>KUM_NDWP_02FA_B</p>	<p><b>E18</b></p>  <p>KUM_NDWP_02FA_B</p>	<p><b>F24</b></p>  <p>KET_090II_06F</p>	<p><b>F25</b></p>  <p>KET_090II_06F</p>
<p><b>I/P-B</b></p>  <p>PKD_ASM_16F_GR</p>	<p><b>M02-L</b></p>  <p>KET_0509_18F</p>	<p><b>R02</b></p>  <p>KET_090II_02M_N_L</p>	<p><b>R03</b></p>  <p>KET_090II_02M_N_L</p>
<p><b>R09</b></p>  <p>KET_090II_06F</p>	<p><b>R10</b></p>  <p>KET_090II_06F</p>	<p><b>R17</b></p>  <p>KET_090II_02M_N_L</p>	<p><b>R18</b></p>  <p>KET_090II_02M_N_L</p>

**TAIL, PARKING & LICENSE LAMPS**

**TAIL, PARKING & LICENSE LAMPS (4)**

**SD928-4**

**MEMO**

COURTESY & TRUNK LAMPS (1)

SD929-1

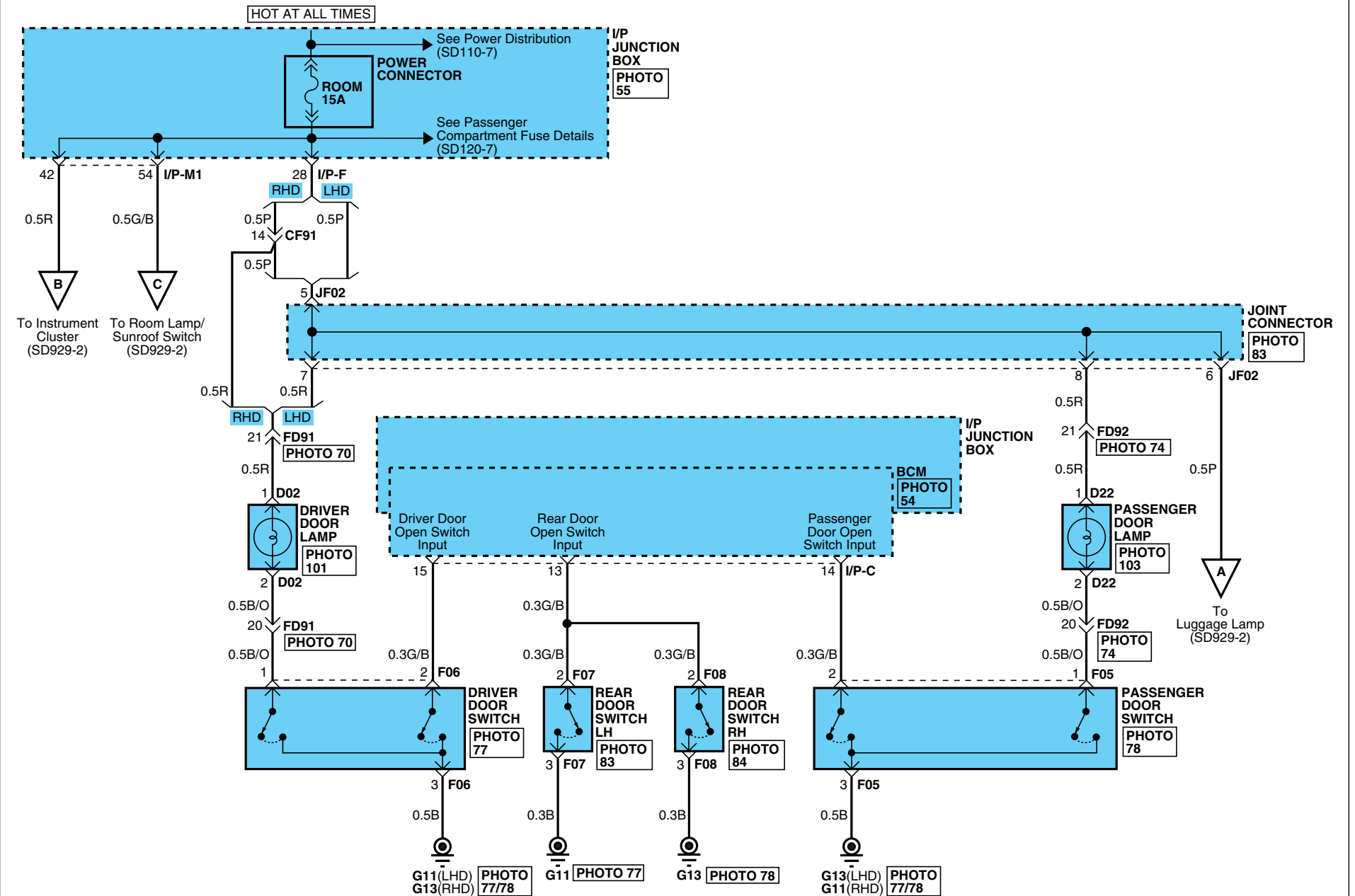

COURTESY & TRUNK LAMPS

COURTESY & TRUNK LAMPS (2)

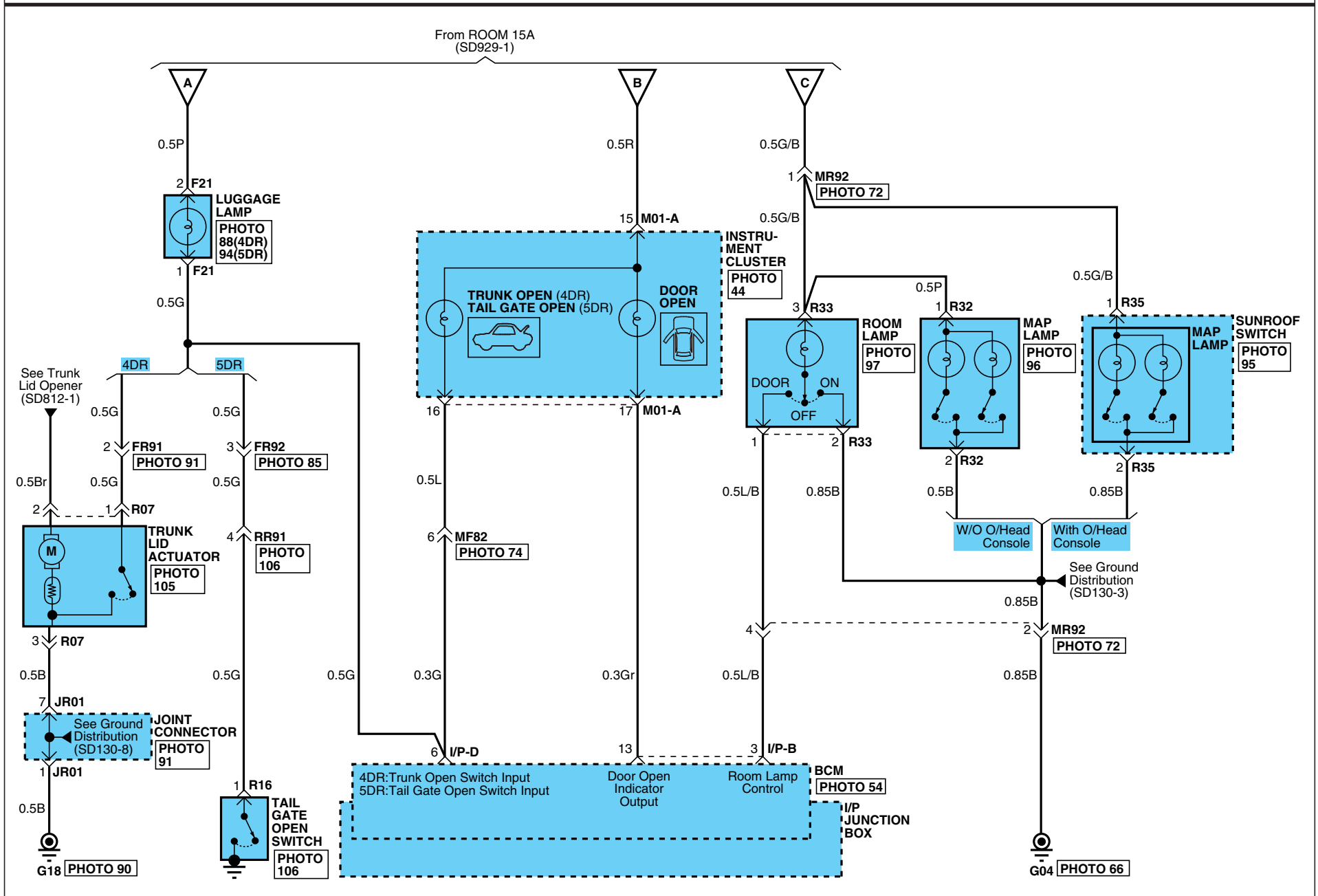

SD929-2



COURTESY & TRUNK LAMPS

COURTESY & TRUNK LAMPS (3)

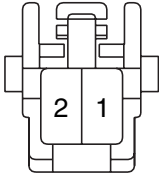
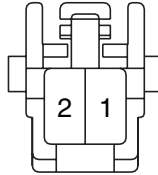
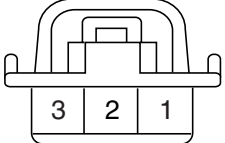
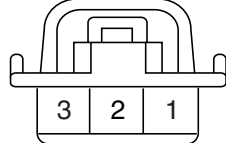
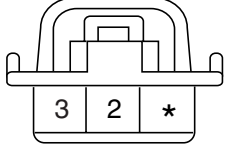
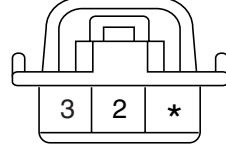
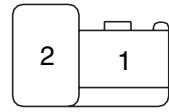
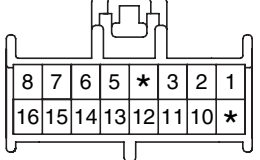
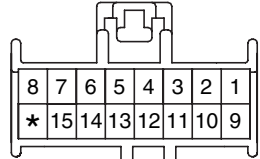
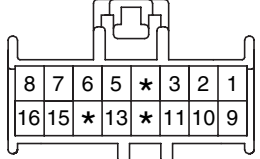
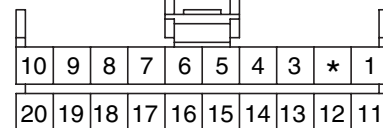
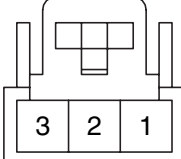
SD929-3

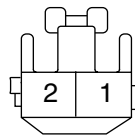
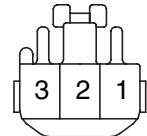
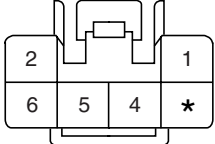
<p><b>D02</b></p>  <p>KET_050_02F_W</p>	<p><b>D22</b></p>  <p>KET_050_02F_W</p>	<p><b>F05</b></p>  <p>KET_62C_03F_DR</p>	<p><b>F06</b></p>  <p>KET_62C_03F_DR</p>
<p><b>F07</b></p>  <p>KET_62C_03F_DR</p>	<p><b>F08</b></p>  <p>KET_62C_03F_DR</p>	<p><b>F21</b></p>  <p>AMP_PLMI02F_W</p>	<p><b>I/P-B</b></p>  <p>PKD_ASM_16F_GR</p>
<p><b>I/P-C</b></p>  <p>PKD_ASM_16F_BR</p>	<p><b>I/P-D</b></p>  <p>PKD_ASM_16F_G</p>	<p><b>M01-A</b></p>  <p>AMP_040_MK1_20F</p>	<p><b>R07</b></p>  <p>AMP_070_03F_B</p>
<p><b>R16</b></p>  <p>KET_090II_1F_N</p>	<p><b>R32</b></p>  <p>KET_090II_02F_W_L</p>	<p><b>R33</b></p>  <p>KET_090II_03F_W</p>	<p><b>R35</b></p>  <p>KET_090II_06F</p>

**COURTESY & TRUNK LAMPS**

**COURTESY & TRUNK LAMPS (4)**

**SD929-4**

**MEMO**

INDICATORS & GAUGES (1)

SD940-1

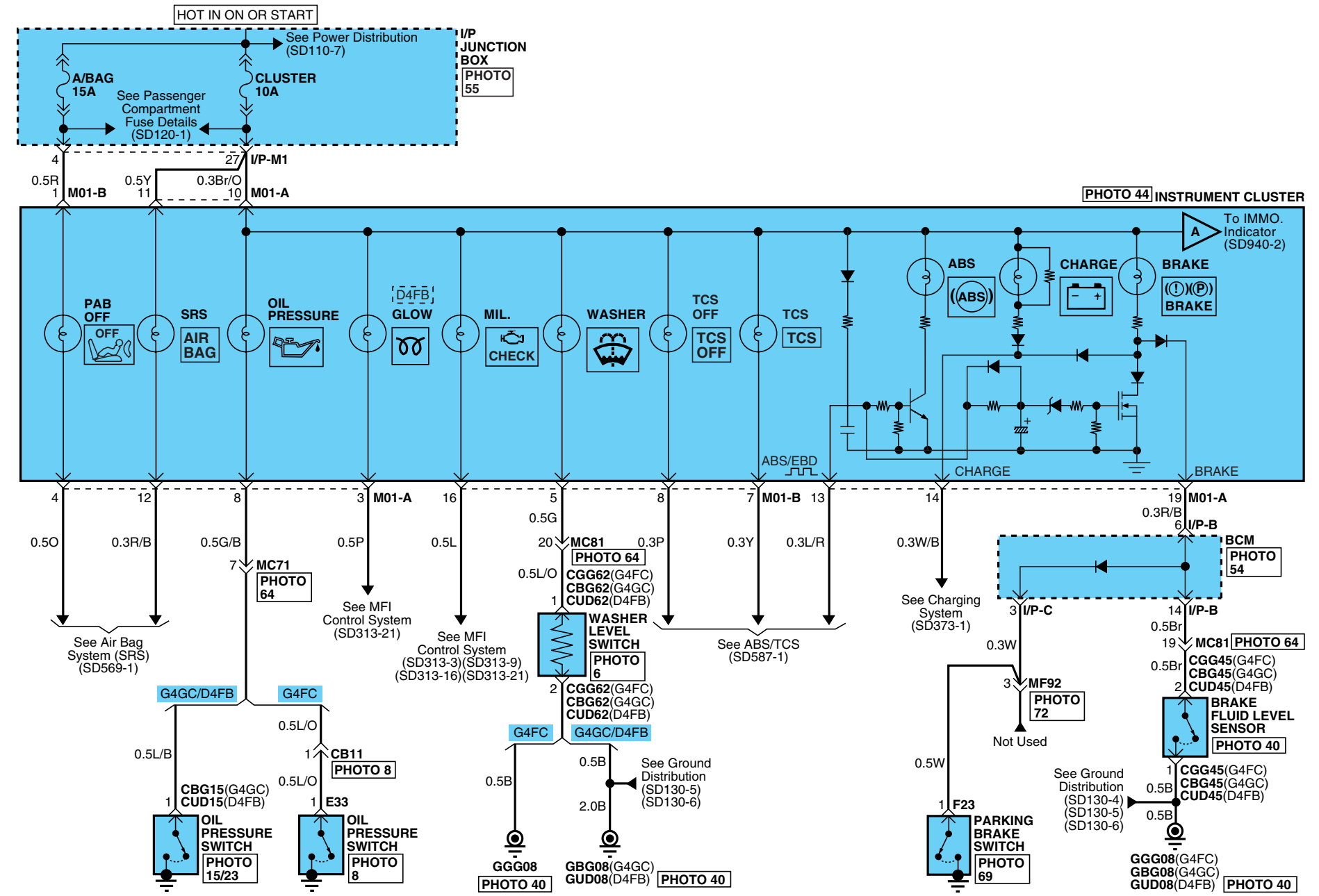



INDICATORS & GAUGES

INDICATORS & GAUGES (2)

SD940-2

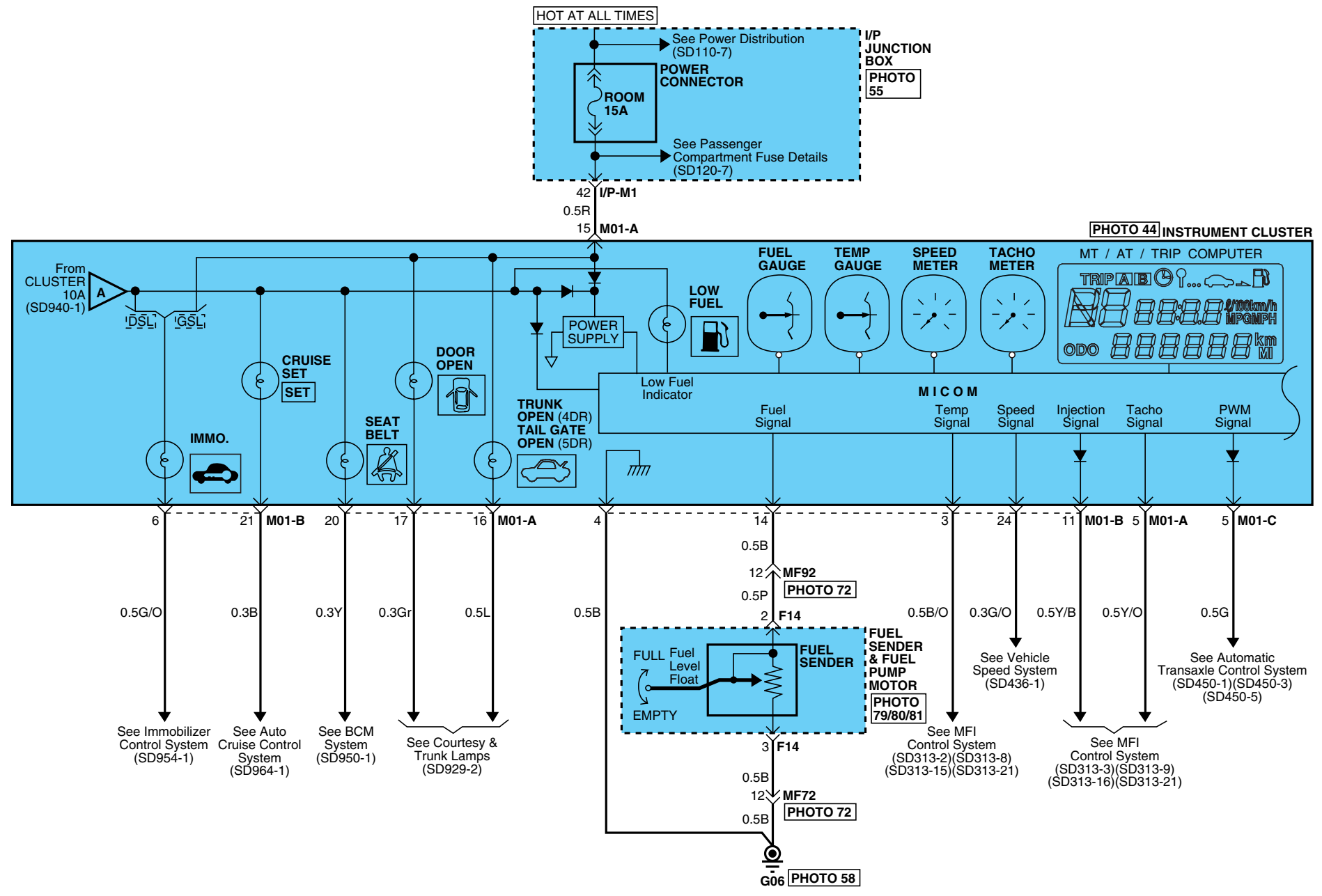







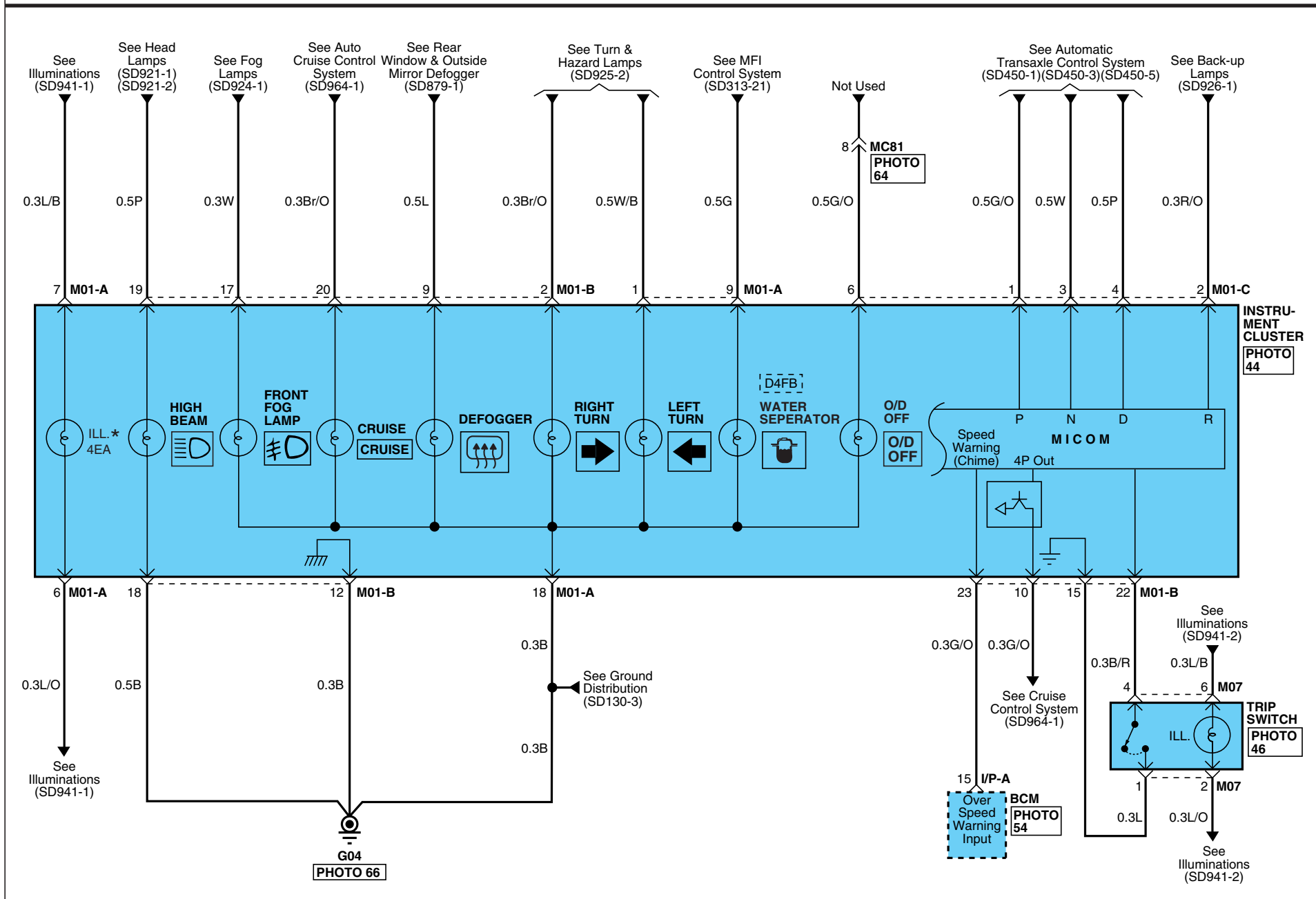

INDICATORS & GAUGES

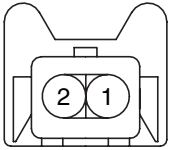
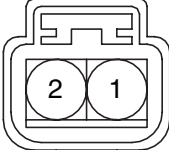
INDICATORS & GAUGES (3)

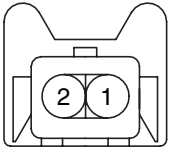
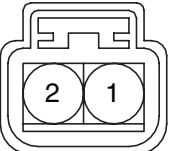
SD940-3

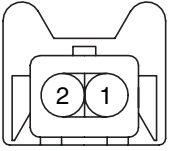
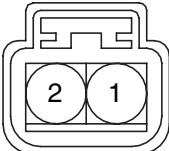

INDICATORS & GAUGES

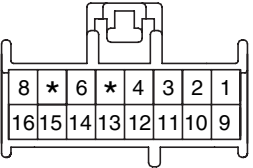
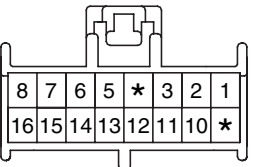
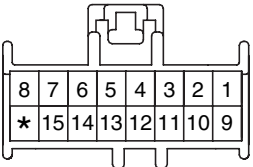
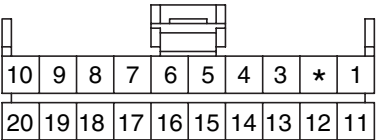
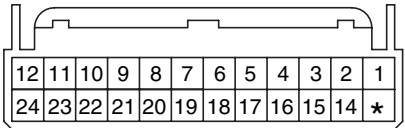
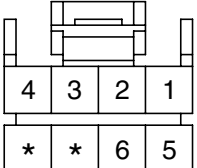
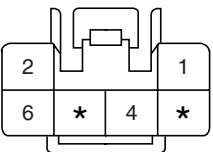
INDICATORS & GAUGES (4)			SD940-4
<p><b>CGG45</b></p>  <p>AMP_JPT_02F_B</p>	<p><b>CGG62</b></p>  <p>KUM_NMWP_02F_B</p>	<p><b>CBG15</b></p>  <p>AMP_PLM2_01F_B</p>	<p><b>CBG45</b></p>  <p>AMP_JPT_02F_B</p>
<p><b>CBG62</b></p>  <p>KUM_NMWP_02F_B</p>	<p><b>CUD15</b></p>  <p>KUM_NMWP_01F_B</p>	<p><b>CUD45</b></p>  <p>AMP_JPT_02F_B</p>	<p><b>CUD62</b></p>  <p>KUM_NMWP_02F_B</p>
<p><b>E33</b></p>  <p>KUM_NMWP_01F_B</p>	<p><b>F14</b></p>  <p>KET_090IWP_05F_Gr_2</p>	<p><b>F23</b></p>  <p>AMP_PLMI_01F_B</p>	<p><b>I/P-A</b></p>  <p>PKD_ASM_16F_B</p>
<p><b>I/P-B</b></p>  <p>PKD_ASM_16F_GR</p>	<p><b>I/P-C</b></p>  <p>PKD_ASM_16F_BR</p>	<p><b>M01-A</b></p>  <p>AMP_040_MK1_20F</p>	<p><b>M01-B</b></p>  <p>AMP_025_I/O_24F</p>
<p><b>M01-C</b></p>  <p>AMP_040_MK_08F</p>	<p><b>M07</b></p>  <p>KET_090II_06F</p>	<p><b>BLANK</b></p>	<p><b>BLANK</b></p>

ILLUMINATIONS (1)

SD941-1

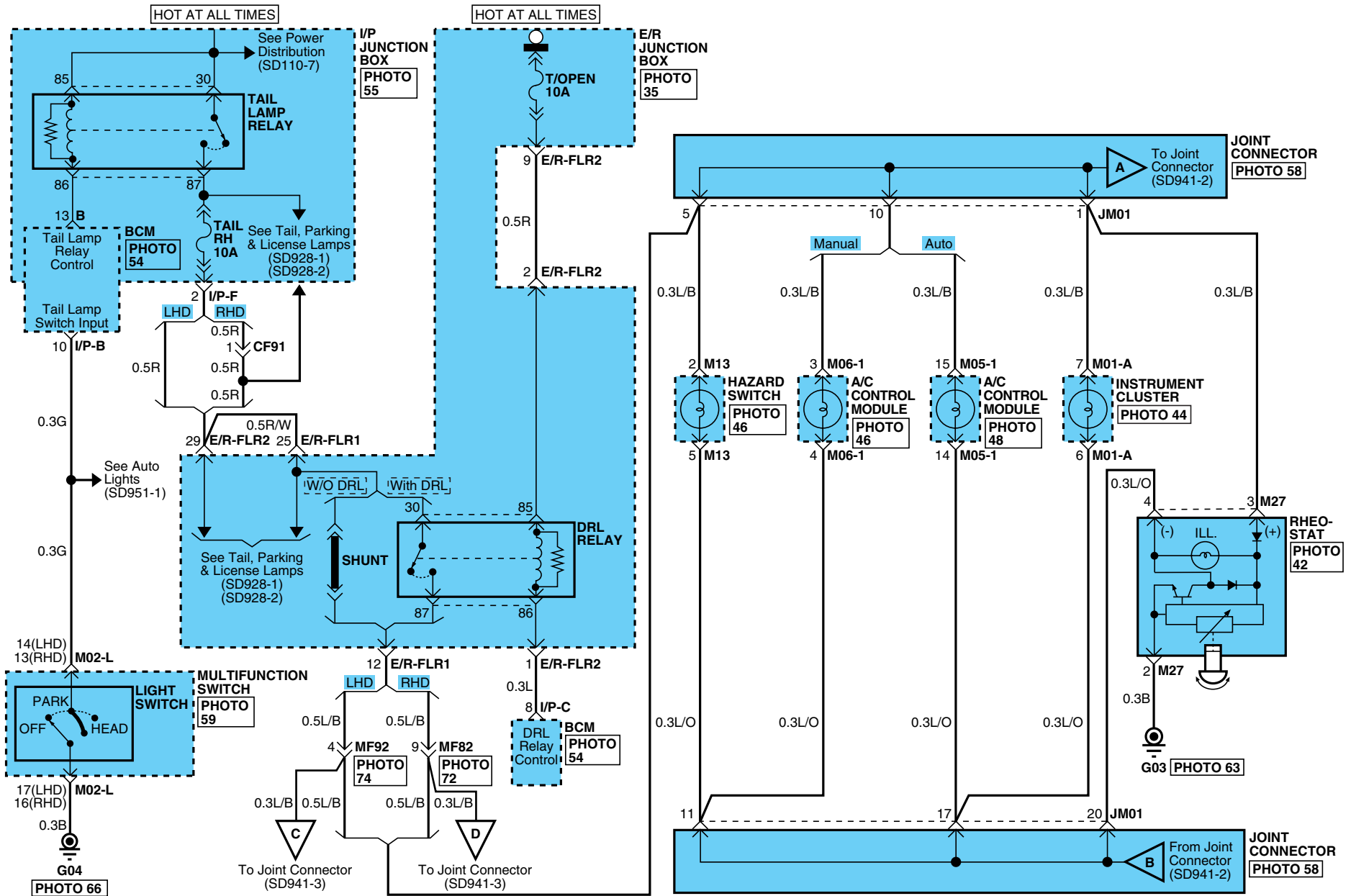

# ILLUMINATIONS

## ILLUMINATIONS (2)

SD941-2

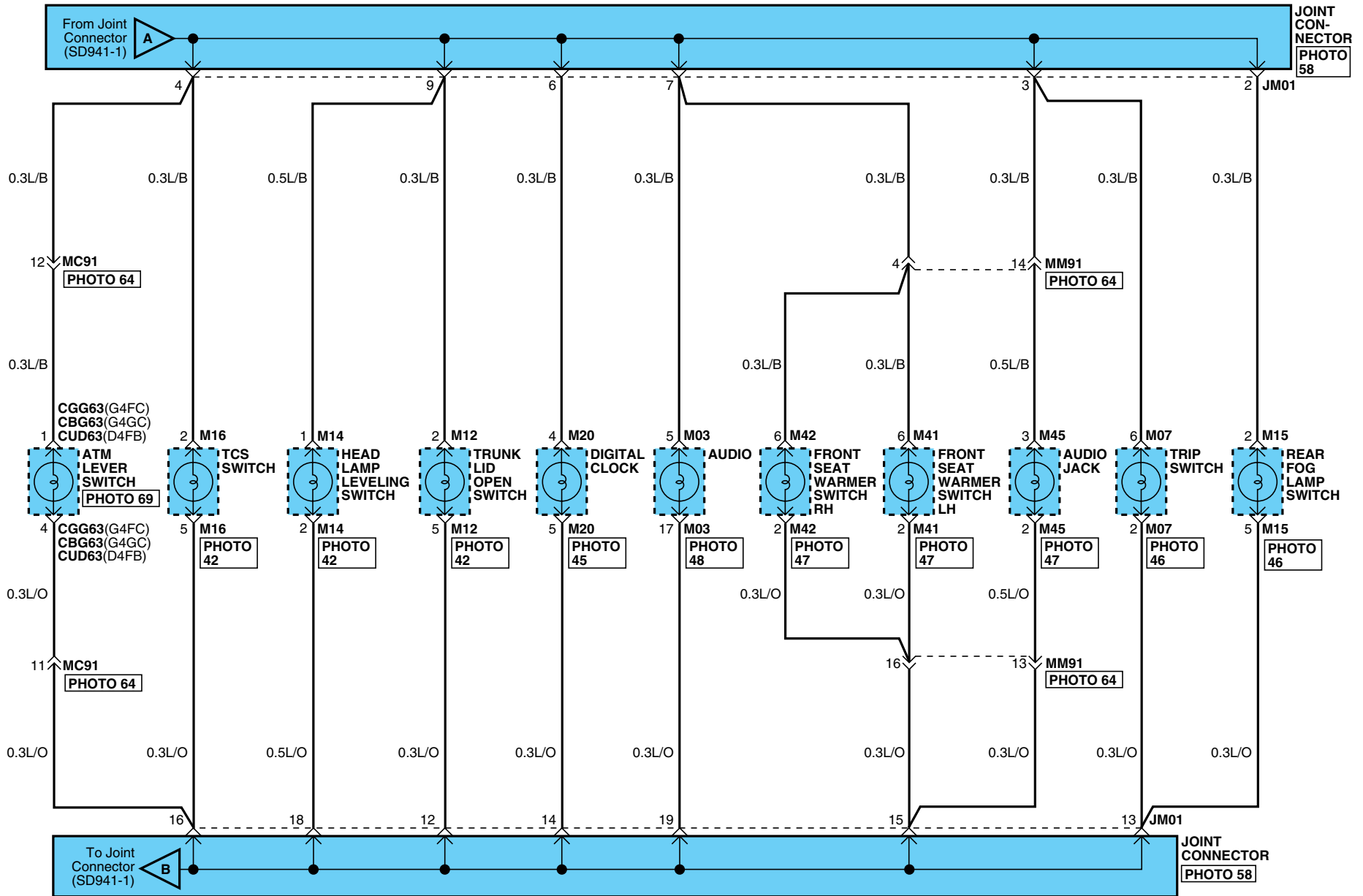

# ILLUMINATIONS

## ILLUMINATIONS (3)

SD941-3

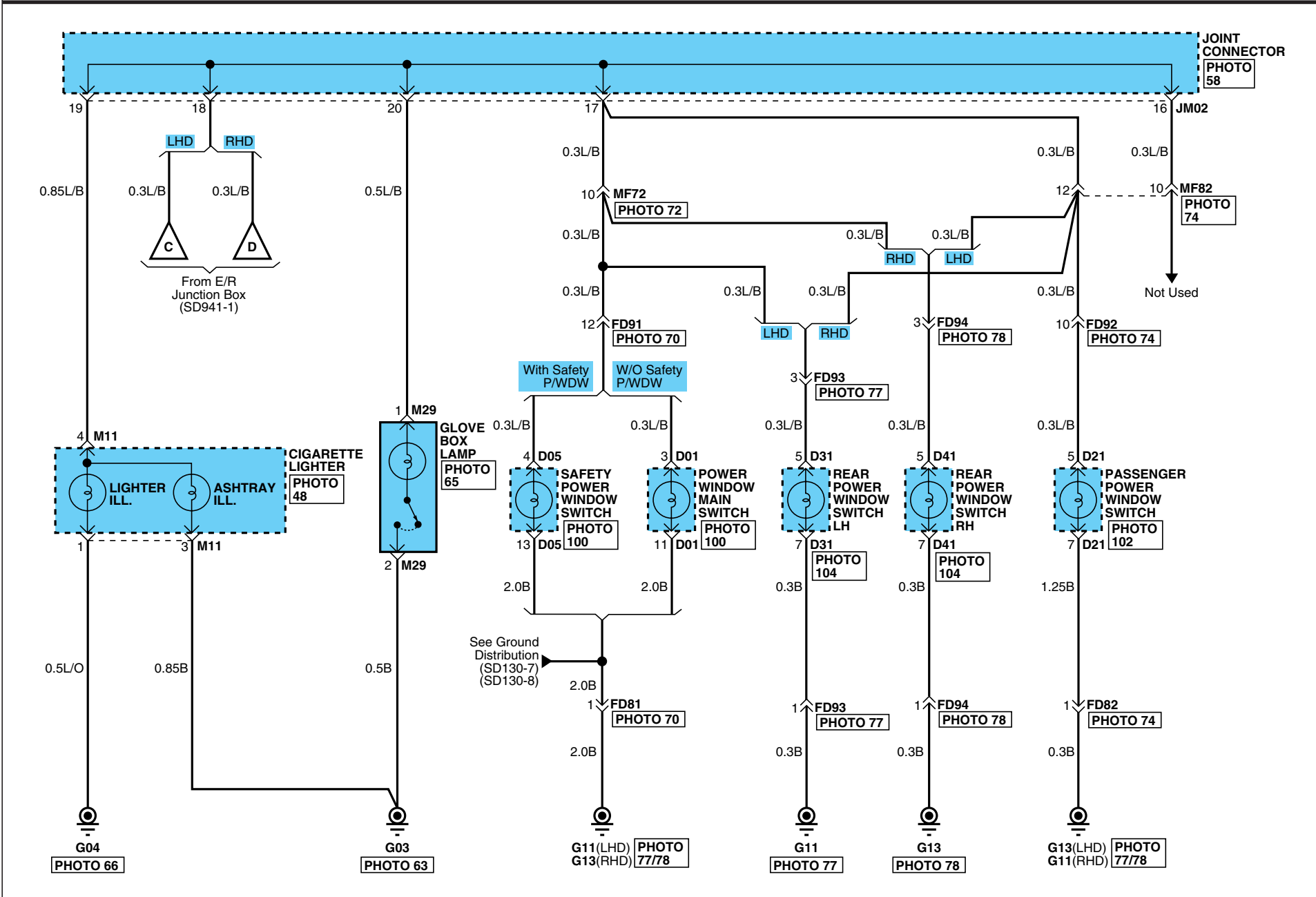

ILLUMINATIONS

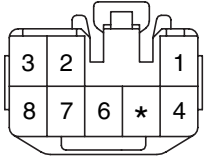
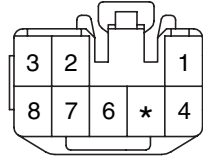
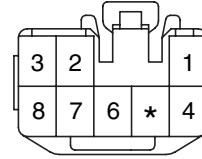
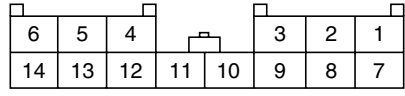
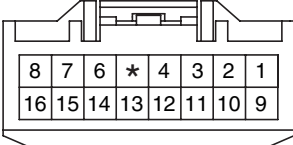
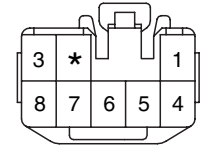
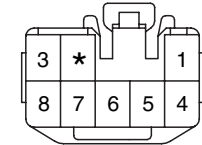
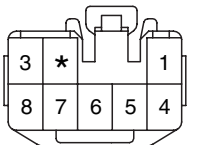
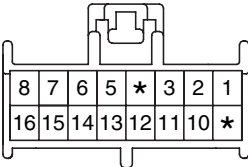
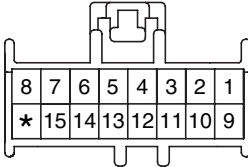
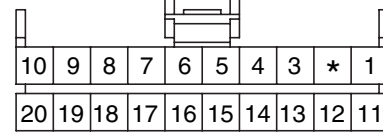
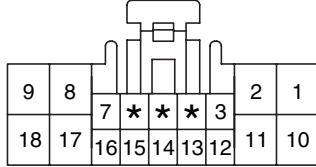
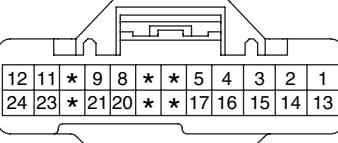
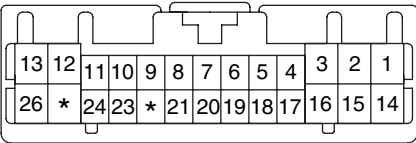
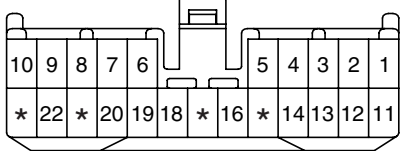
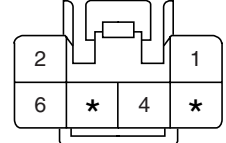
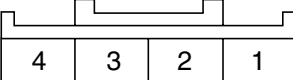
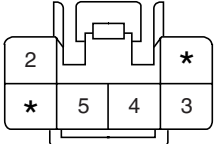
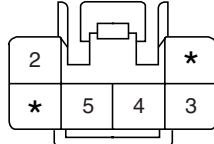
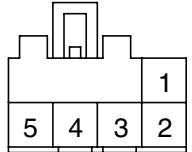
ILLUMINATIONS (4)			SD941-4
<p><b>CGG63</b></p>  <p>KET_090II_08F_W</p>	<p><b>CBG63</b></p>  <p>KET_090II_08F_W</p>	<p><b>CUD63</b></p>  <p>KET_090II_08F_W</p>	<p><b>D01</b></p>  <p>KET_090II_14F_SW</p>
<p><b>D05</b></p>  <p>AMP_090III_16F_W</p>	<p><b>D21</b></p>  <p>KET_090II_08F_B</p>	<p><b>D31</b></p>  <p>KET_090II_08F_B</p>	<p><b>D41</b></p>  <p>KET_090II_08F_B</p>
<p><b>I/P-B</b></p>  <p>PKD_ASM_16F_GR</p>	<p><b>I/P-C</b></p>  <p>PKD_ASM_16F_BR</p>	<p><b>M01-A</b></p>  <p>AMP_040_MK1_20F</p>	<p><b>M02-L</b></p>  <p>KET_0509_18F</p>
<p><b>M03</b></p>  <p>KET_0409_24F</p>	<p><b>M05-1</b></p>  <p>KET_PCB_26F</p>	<p><b>M06-1</b></p>  <p>KET_050_23F_W</p>	<p><b>M07</b></p>  <p>KET_090II_06F</p>
<p><b>M11</b></p>  <p>AMP_090III_4F_W</p>	<p><b>M12</b></p>  <p>KET_090II_06F_Y</p>	<p><b>M13</b></p>  <p>KET_090II_06F_G</p>	<p><b>M14</b></p>  <p>KUM_CDR_05F</p>

ILLUMINATIONS

ILLUMINATIONS (5)

SD941-5

M15

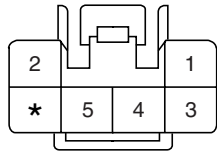

KET\_090II\_06F\_B

M16

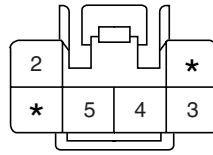

KET\_090II\_06F\_L

M20

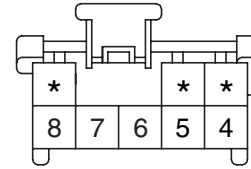

KUM\_AR\_08F\_W

M27

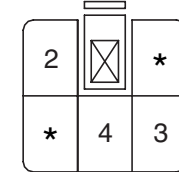

KET\_118PA\_05F\_Br

M29

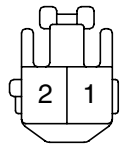

KET\_090II\_02F\_B

M41

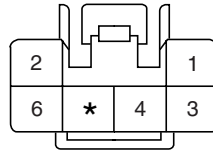

KET\_090II\_06F\_B

M42

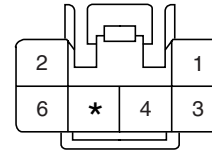

KET\_090II\_06F\_L

M45

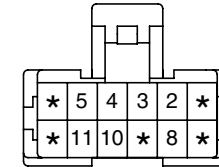

KET\_040SP\_12F\_W



**ILLUMINATIONS**

**ILLUMINATIONS (6)**

**SD941-6**

**MEMO**

DIGITAL CLOCK & CIGARETTE LIGHTER (POWER OUTLET) ED22AFC8

DIGITAL CLOCK & CIGARETTE LIGHTER (POWER OUTLET) (1)

SD945-1

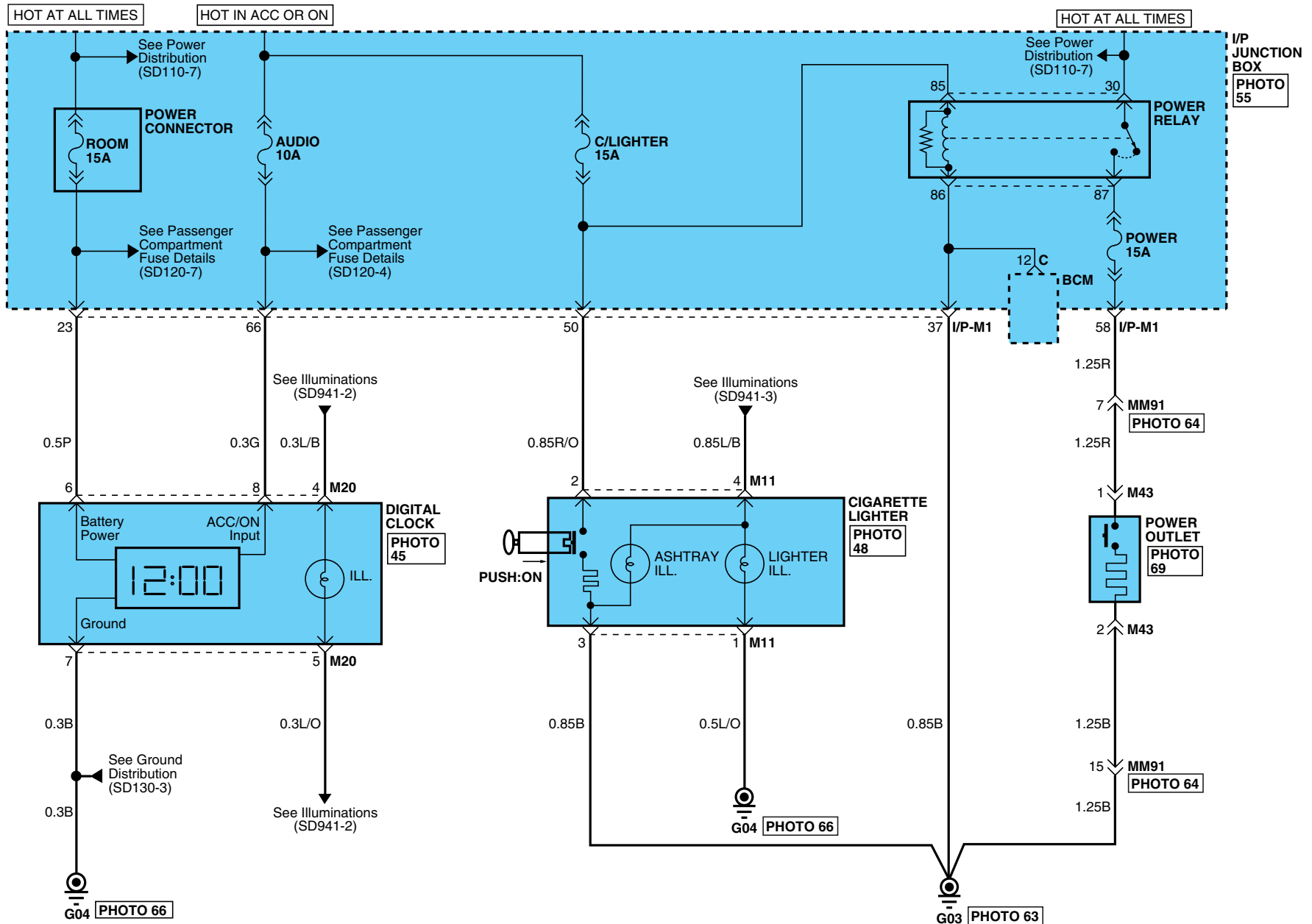

DIGITAL CLOCK & CIGARETTE LIGHTER (POWER OUTLET)

DIGITAL CLOCK & CIGARETTE LIGHTER (POWER OUTLET) (2)

SD945-2

M11

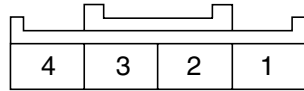

AMP\_090III\_4F\_W

M20

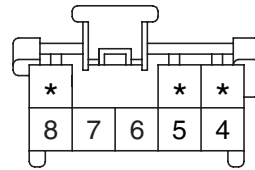

KUM\_AR\_08F\_W

M43

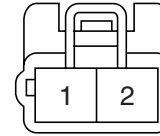

KET\_090II\_2M\_B

BLANK

BCM (BODY CONTROL MODULE) SYSTEM EAD67FB4

BCM (BODY CONTROL MODULE) SYSTEM (1)

SD950-1

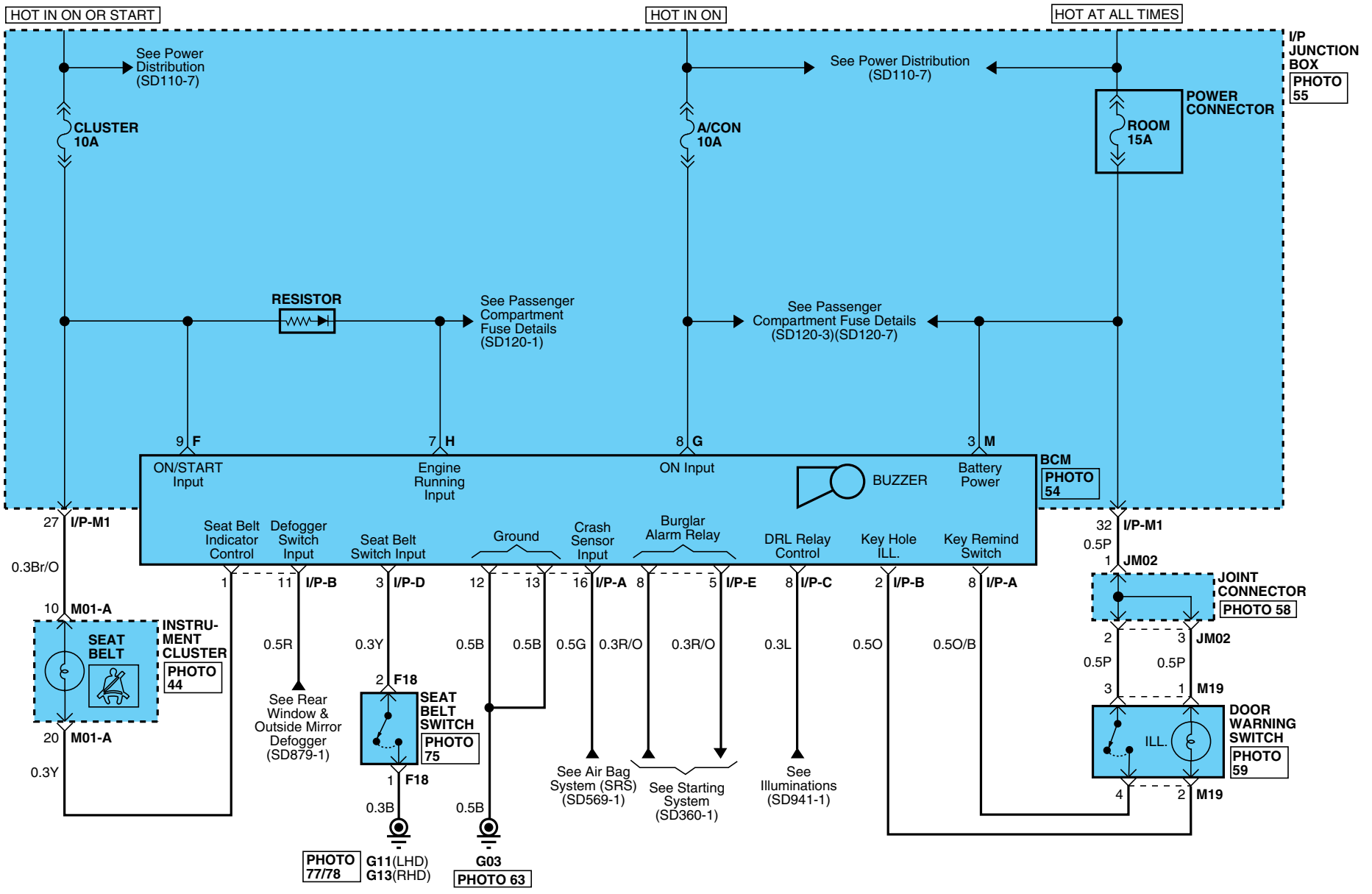

BCM (BODY CONTROL MODULE) SYSTEM

BCM (BODY CONTROL MODULE) SYSTEM (2)

SD950-2

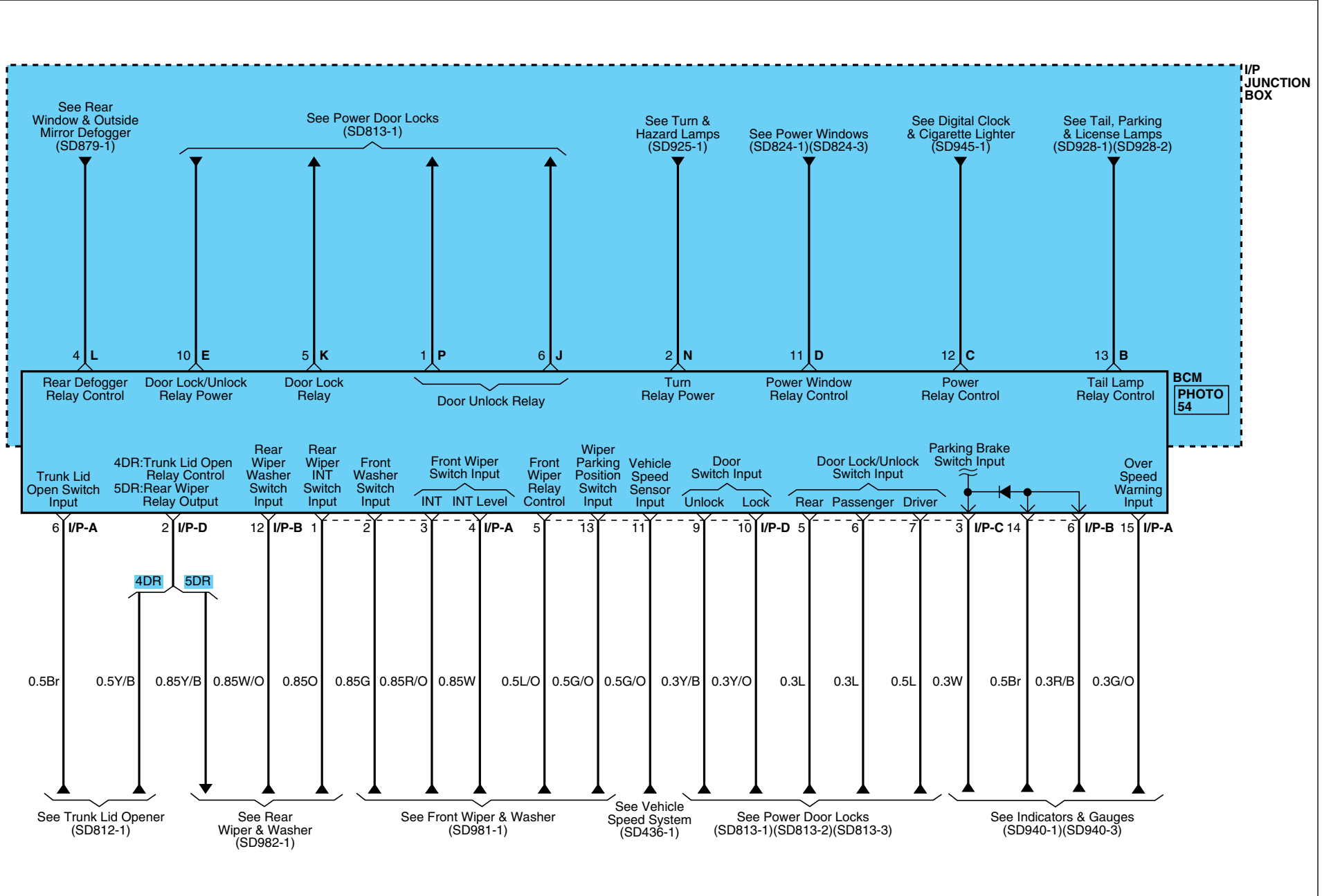

BCM (BODY CONTROL MODULE) SYSTEM

BCM (BODY CONTROL MODULE) SYSTEM (3)

SD950-3

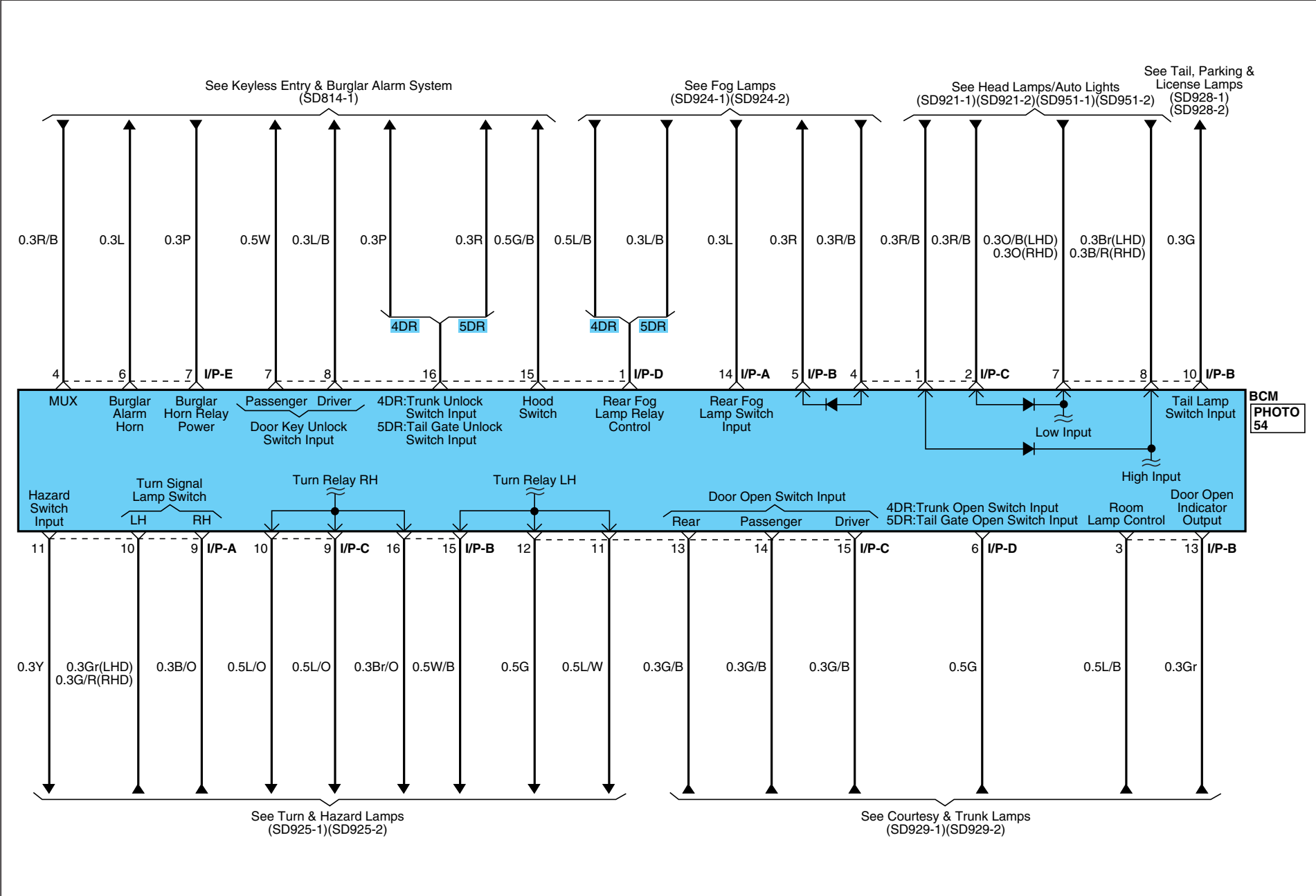

BCM PHOTO 54

### BCM (BODY CONTROL MODULE) SYSTEM

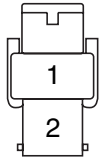
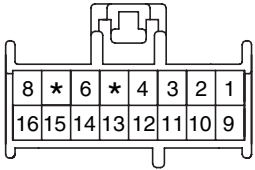
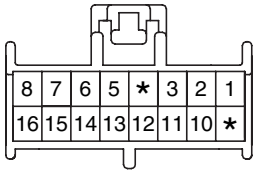
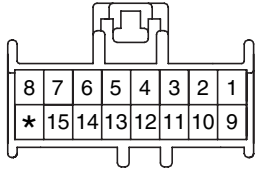
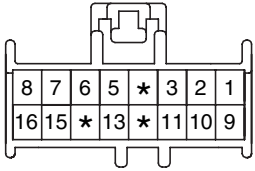
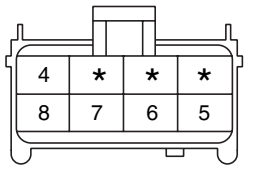
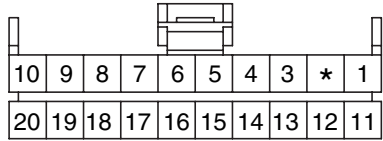
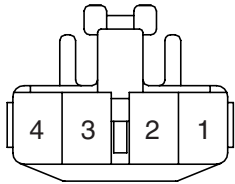
BCM (BODY CONTROL MODULE) SYSTEM (4)			SD950-4
<p><b>F18</b></p>  <p>KUM_DSD_250_02F_W</p>	<p><b>I/P-A</b></p>  <p>PKD_ASM_16F_B</p>	<p><b>I/P-B</b></p>  <p>PKD_ASM_16F_GR</p>	<p><b>I/P-C</b></p>  <p>PKD_ASM_16F_BR</p>
<p><b>I/P-D</b></p>  <p>PKD_ASM_16F_G</p>	<p><b>I/P-E</b></p>  <p>PKD_MIC64_08F_B</p>	<p><b>M01-A</b></p>  <p>AMP_040_MK1_20F</p>	<p><b>M19</b></p>  <p>KET_090II_04F_B</p>

AUTO LIGHTS (1)

SD951-1

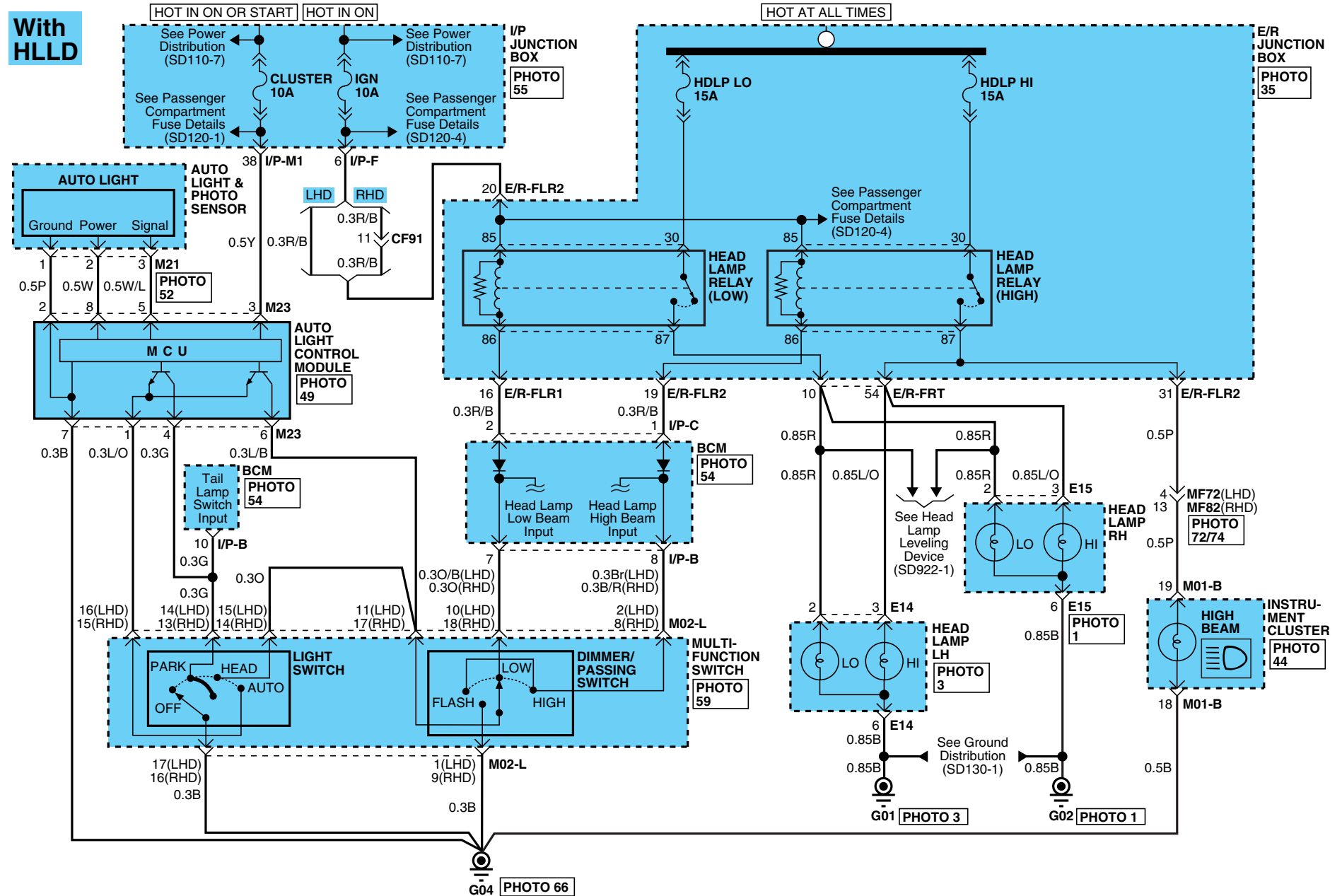



# AUTO LIGHTS

## AUTO LIGHTS (2)

SD951-2

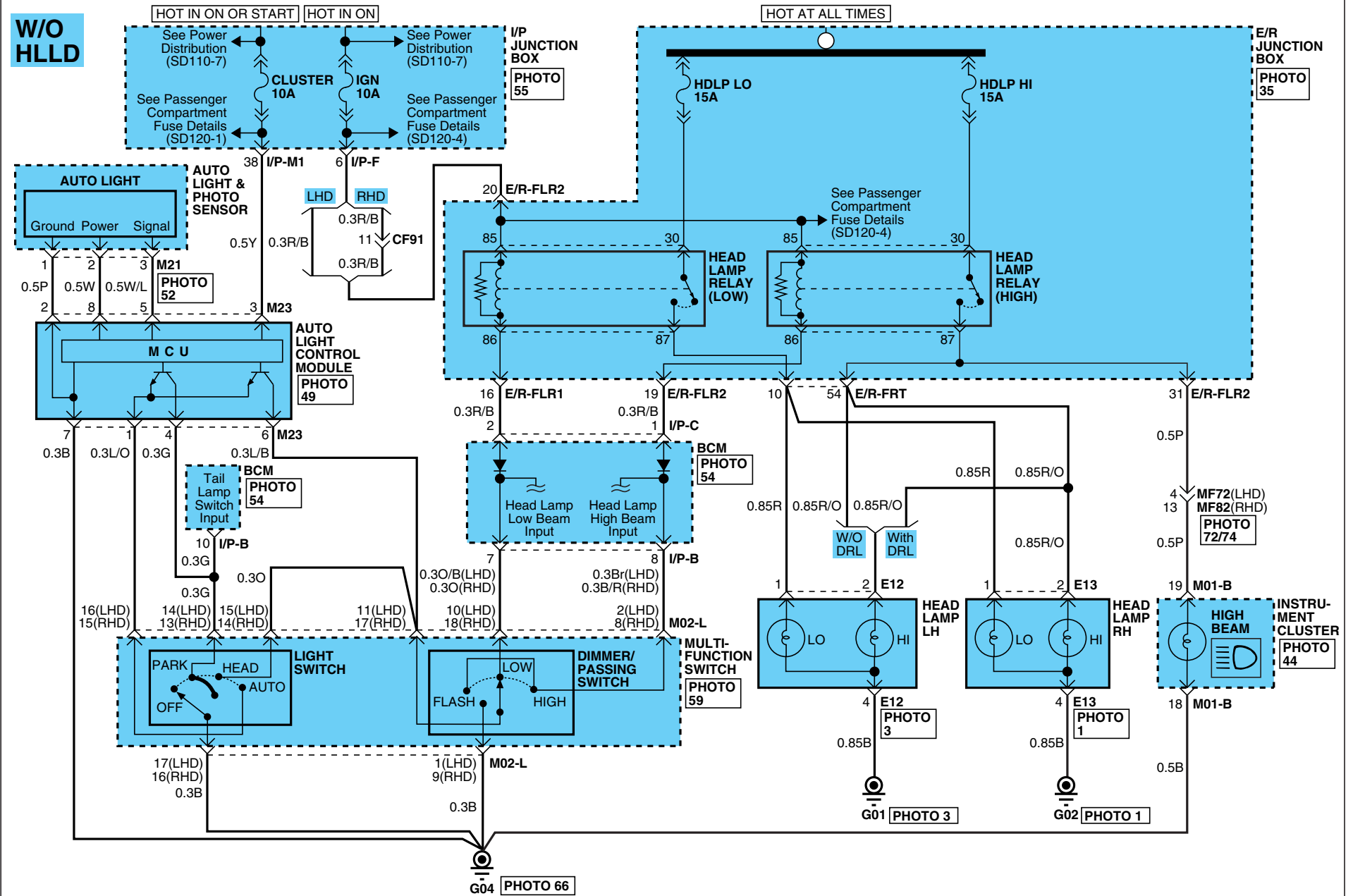

**AUTO LIGHTS**

**AUTO LIGHTS (3)**

**SD951-3**

**E12**

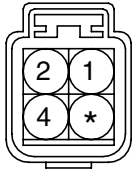

KUM\_NMWP\_04F\_B

**E13**

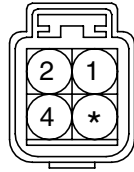

KUM\_NMWP\_04F\_B

**E14**

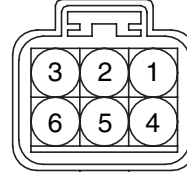

KUM\_NMWP\_06F\_B

**E15**

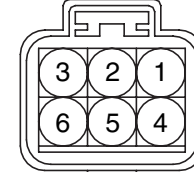

KUM\_NMWP\_06F\_B

**I/P-B**

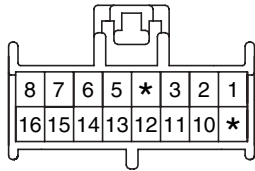

PKD\_ASM\_16F\_GR

**I/P-C**

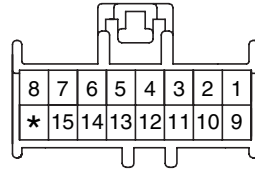

PKD\_ASM\_16F\_BR

**M01-B**

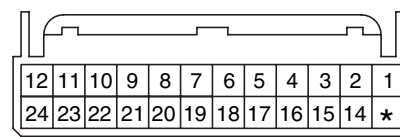

AMP\_025\_I/O\_24F

**M02-L**

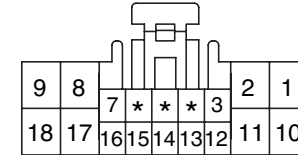

KET\_0509\_18F

**M21**

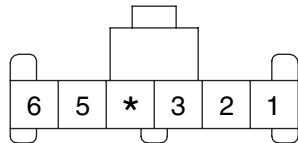

KET\_91A\_08F\_W

**M23**

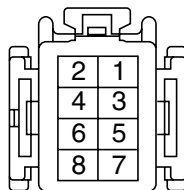

KET\_91A\_08F\_Br

**BLANK**

**BLANK**

**AUTO LIGHTS**

**AUTO LIGHTS (4)**

**SD951-4**

**MEMO**

IMMOBILIZER CONTROL SYSTEM (1)

SD954-1

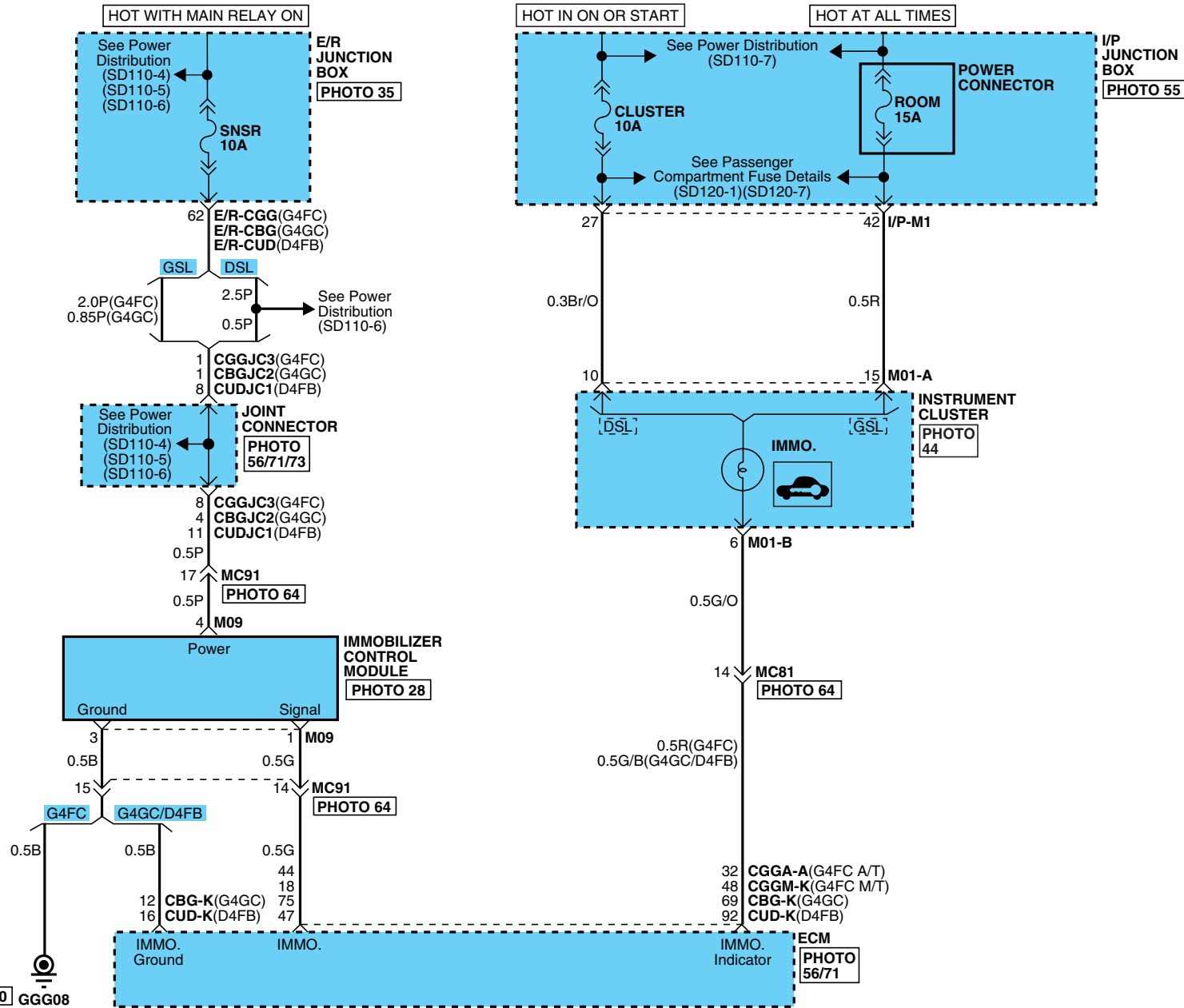

IMMOBILIZER CONTROL SYSTEM

IMMOBILIZER CONTROL SYSTEM (2)

SD954-2

CGGA-A

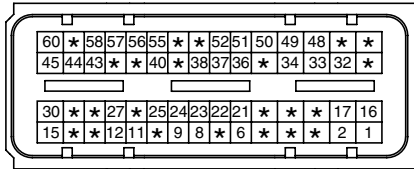

AMP\_ECU\_60F\_B

CGGM-K

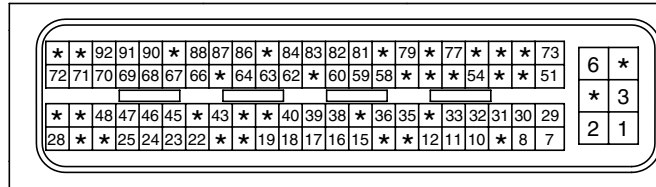

AMP\_ECU\_94F\_B

BLANK

CBG-K

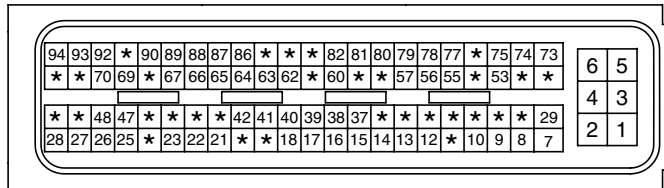

AMP\_ECU\_94F\_B

CUD-K

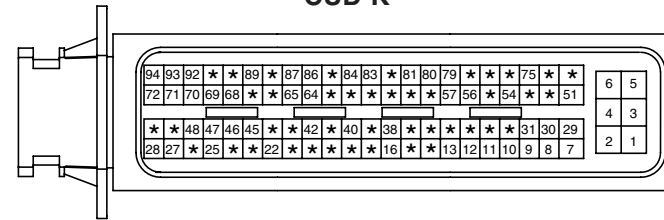

AMP\_ECU\_94F\_B

M01-A

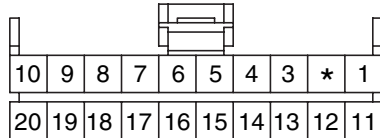

AMP\_040\_MK1\_20F

M01-B

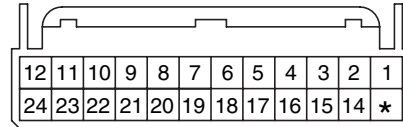

AMP\_025\_I/O\_24F

M09

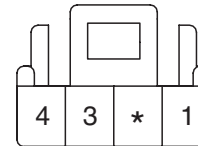

KET\_SP\_04F\_W

BLANK

AUDIO SYSTEM (1)

SD961-1

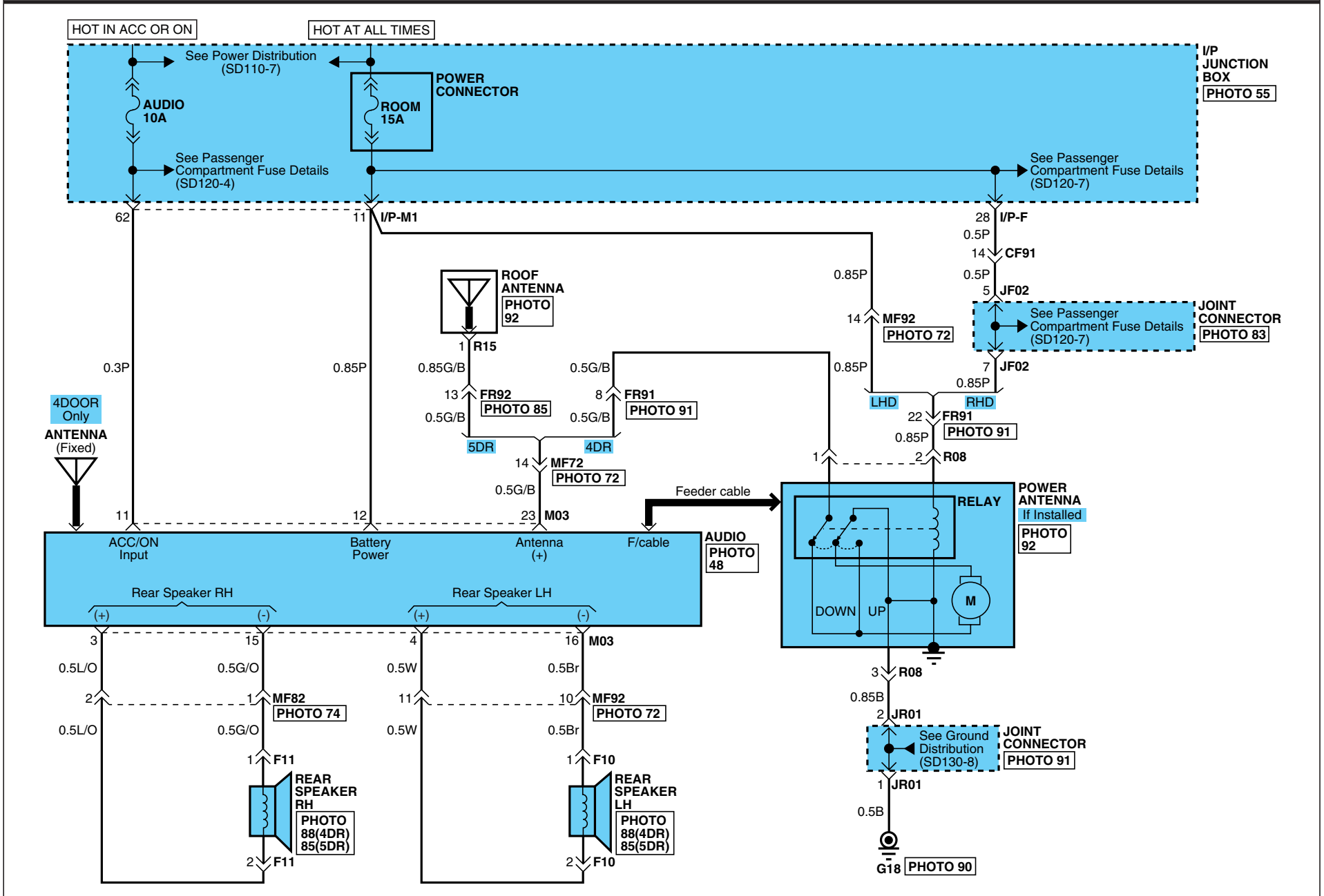

# AUDIO SYSTEM

## AUDIO SYSTEM (2)

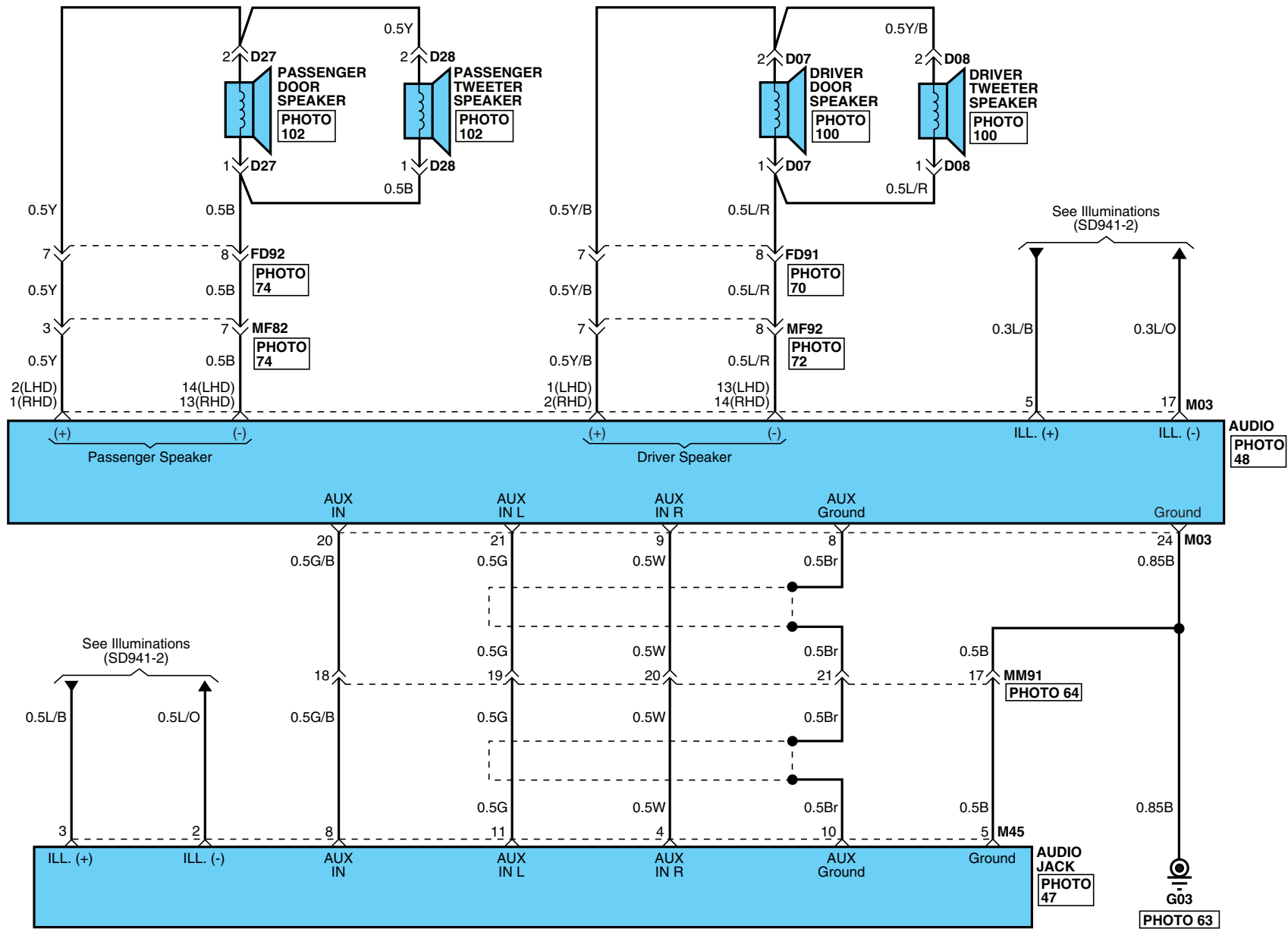

SD961-2



**AUDIO SYSTEM**

**AUDIO SYSTEM (3)**

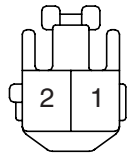
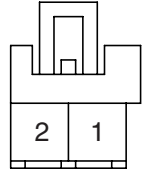
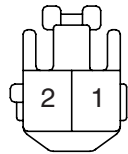
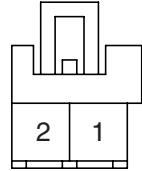
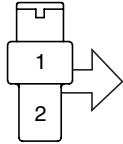
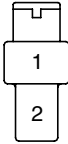
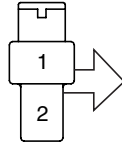
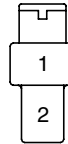
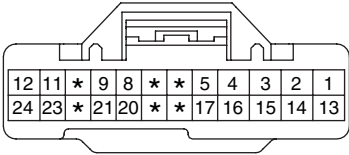
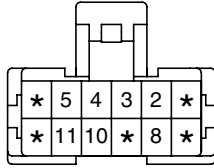
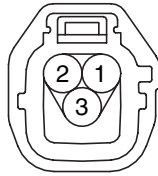
**SD961-3**

<p><b>D07</b></p>  <p>KET_090II_02F_B</p>	<p><b>D08</b></p>  <p>KET_090III_02F_W_L</p>	<p><b>D27</b></p>  <p>KET_090III_02F_W_L</p>	<p><b>D28</b></p>  <p>KUM_CDR_02F_W</p>
<p><b>F10 (4DR)</b></p>  <p>KET_250_02F</p>	<p><b>F10 (5DR)</b></p>  <p>KET_250_02F_B</p>	<p><b>F11 (4DR)</b></p>  <p>KET_250_02F_B</p>	<p><b>F11 (5DR)</b></p>  <p>KET_250_02F_B</p>
<p><b>M03</b></p>  <p>KET_0409_24F</p>	<p><b>M45</b></p>  <p>KET_040SP_12F_W</p>	<p><b>R08</b></p>  <p>KET_090IWP_03F_B</p>	<p><b>R15</b></p>  <p>CR01F014</p>



**AUDIO SYSTEM**

**AUDIO SYSTEM (4)**

**SD961-4**

**MEMO**

AUTO CRUISE CONTROL SYSTEM (1)

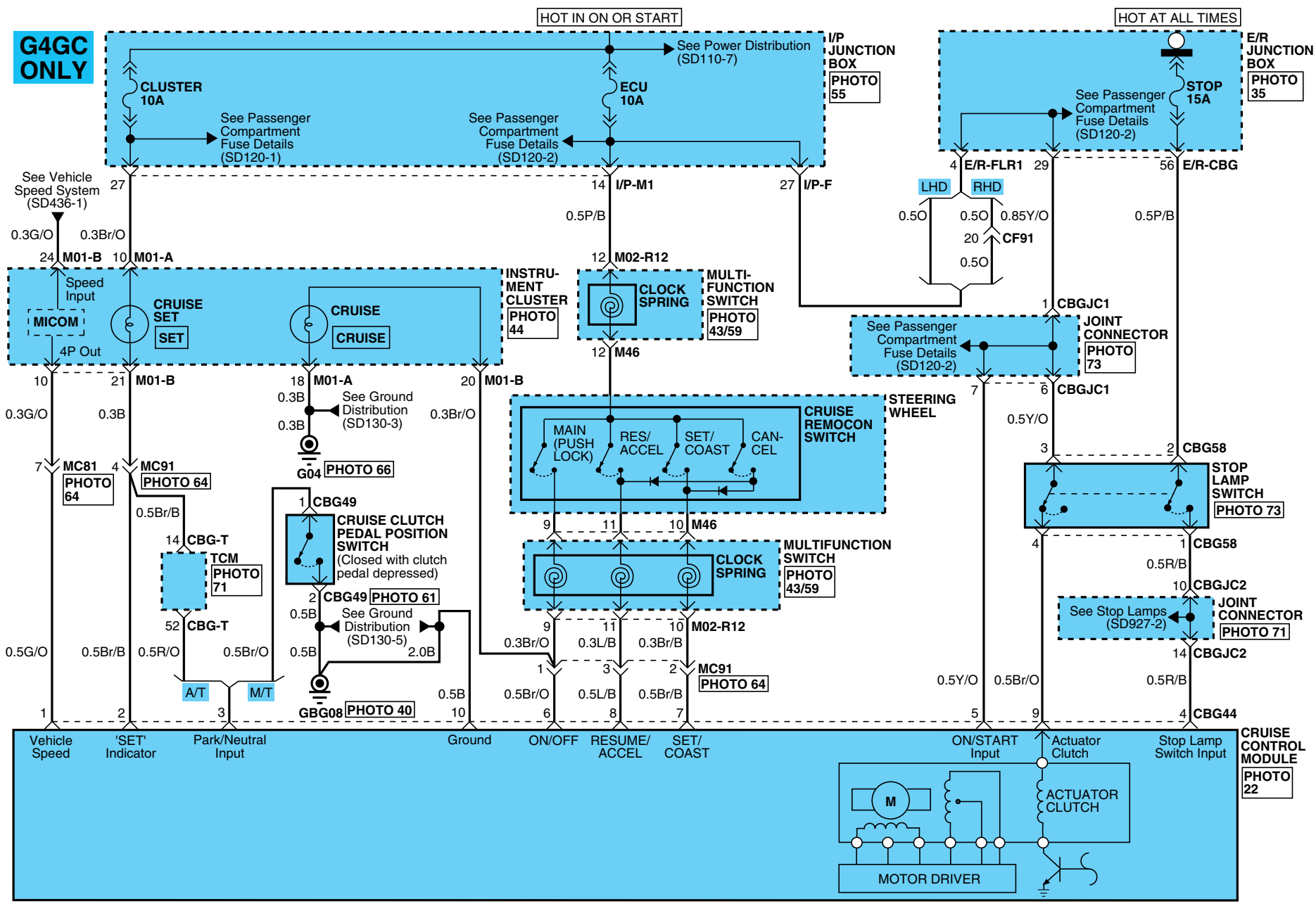

**AUTO CRUISE CONTROL SYSTEM**

**AUTO CRUISE CONTROL SYSTEM (2)**

**SD964-2**

**CBG-T**

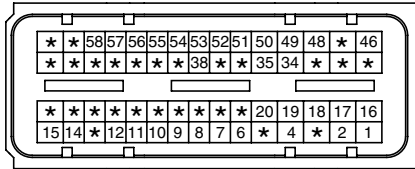

AMP\_ECU\_60F\_B

**CBG44**

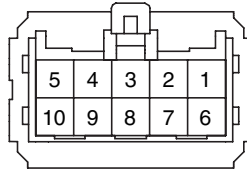

PKD\_150W\_10F\_B

**CBG49**



KET\_250DL\_02F\_B

**CBG58**

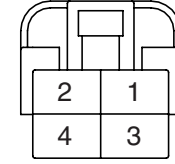

KET\_250DL\_04F

**M01-A**

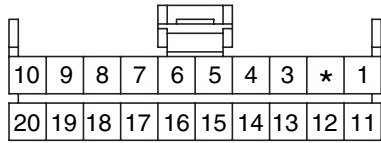

AMP\_040\_MK1\_20F

**M01-B**

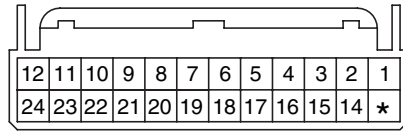

AMP\_025\_I/O\_24F

**M02-R12**

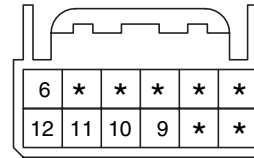

AMP\_025\_12F\_W

**M46**

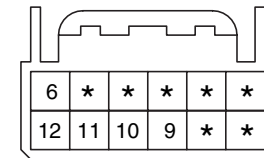

AMP\_025\_12F\_W

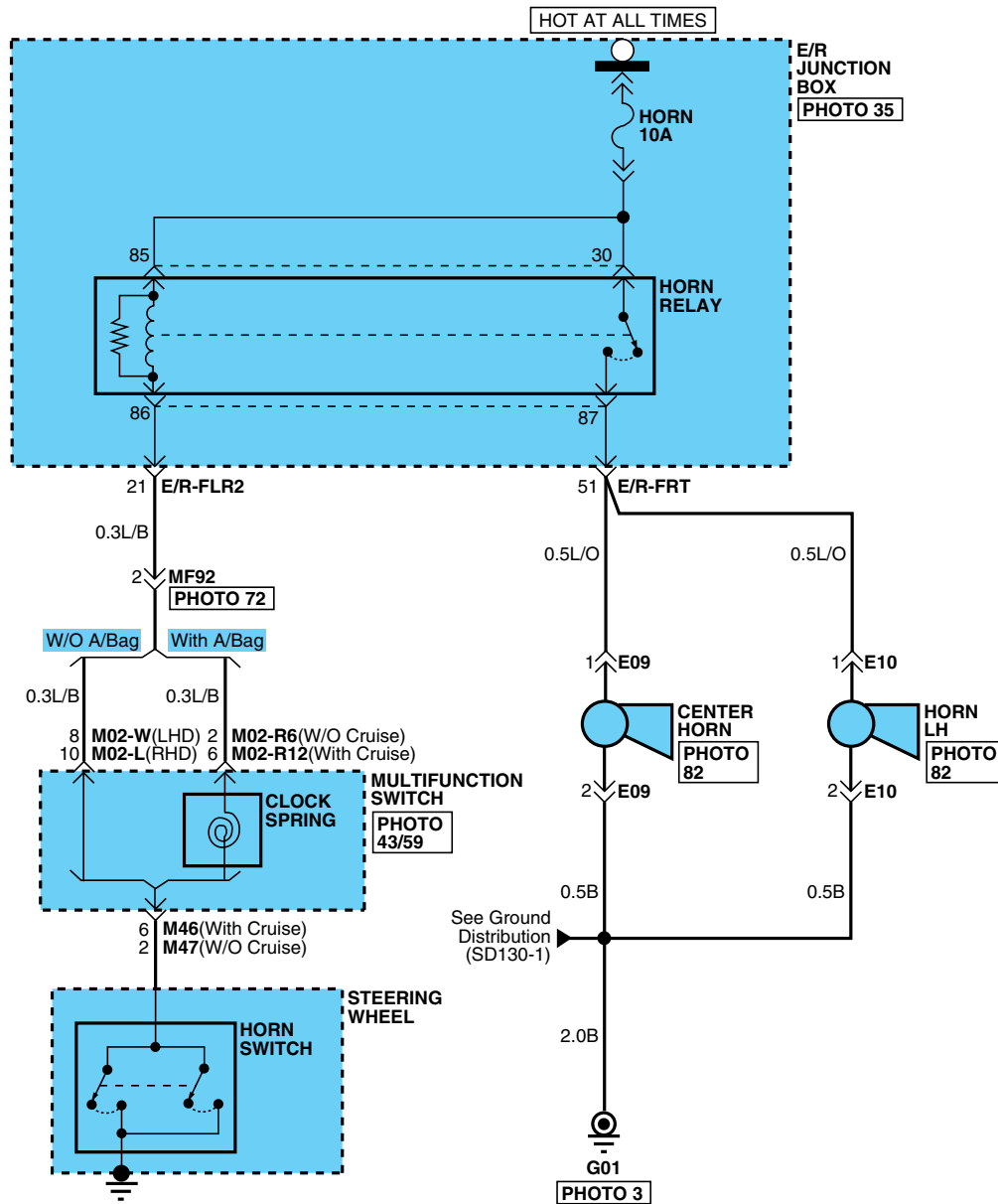

**HORNS**

**HORNS (2)**

**SD968-2**

**E09**

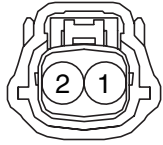

MLX\_HORN\_02F\_B

**E10**

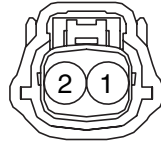

MLX\_HORN\_02F\_B

**M02-L**

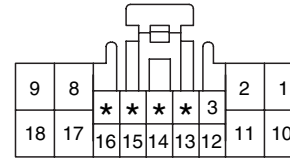

KET\_0509\_18F

**M02-R6**

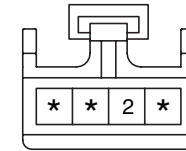

FUR\_FA\_04F\_B\_AB

**M02-R12**

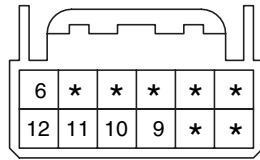

AMP\_025\_12F\_W

**M02-W**

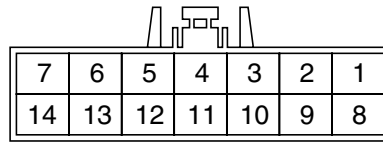

KET090II\_14F\_SW

**M46**

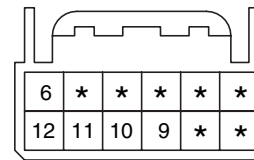

AMP\_025\_12F\_W

**M47**

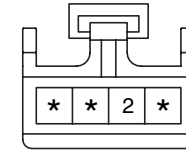

FUR\_FA\_04F\_B\_AB

BLOWER & A/C CONTROLS

E41397A2

BLOWER & A/C CONTROLS (AUTO) (1)

SD971-1

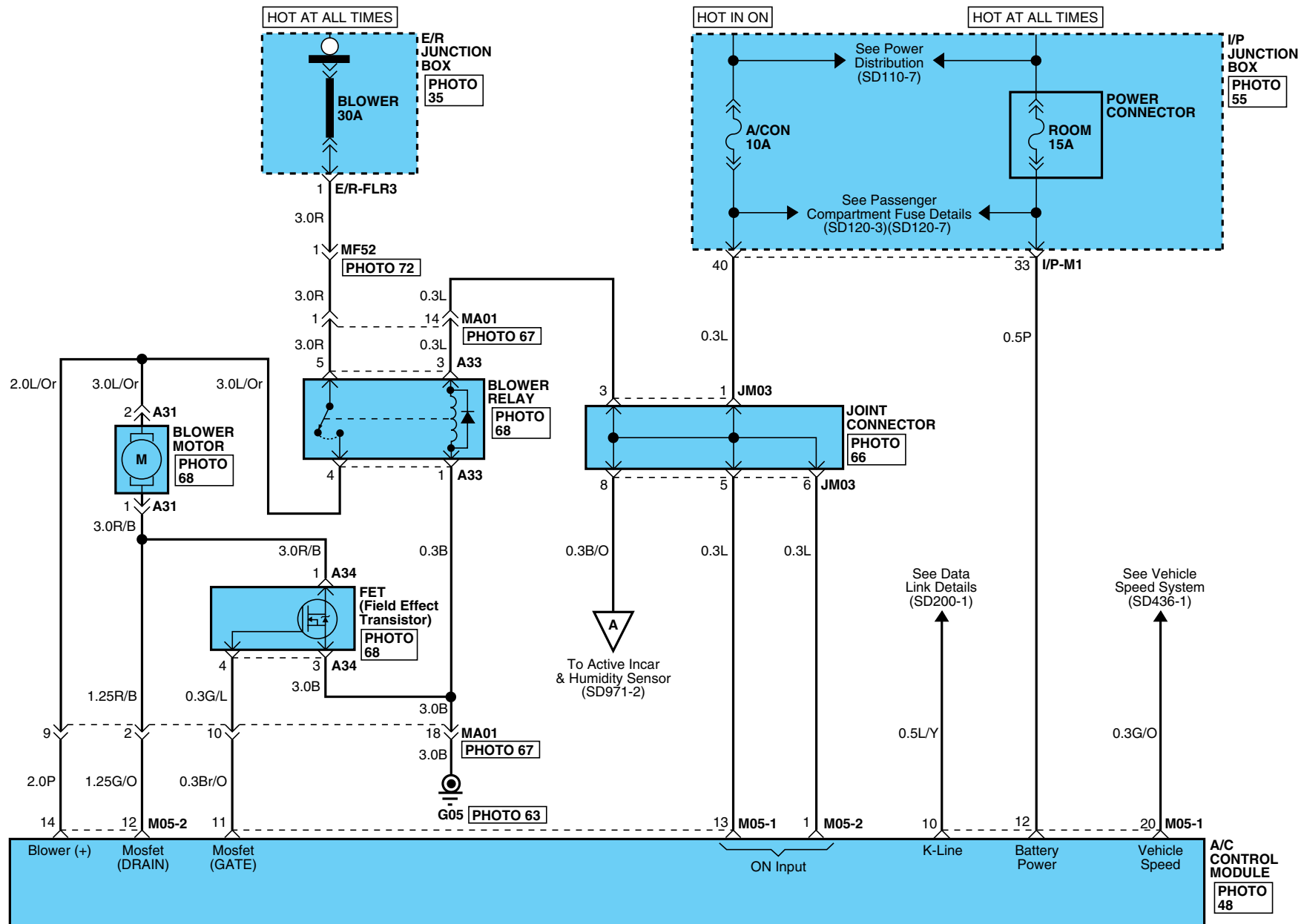

BLOWER & A/C CONTROLS

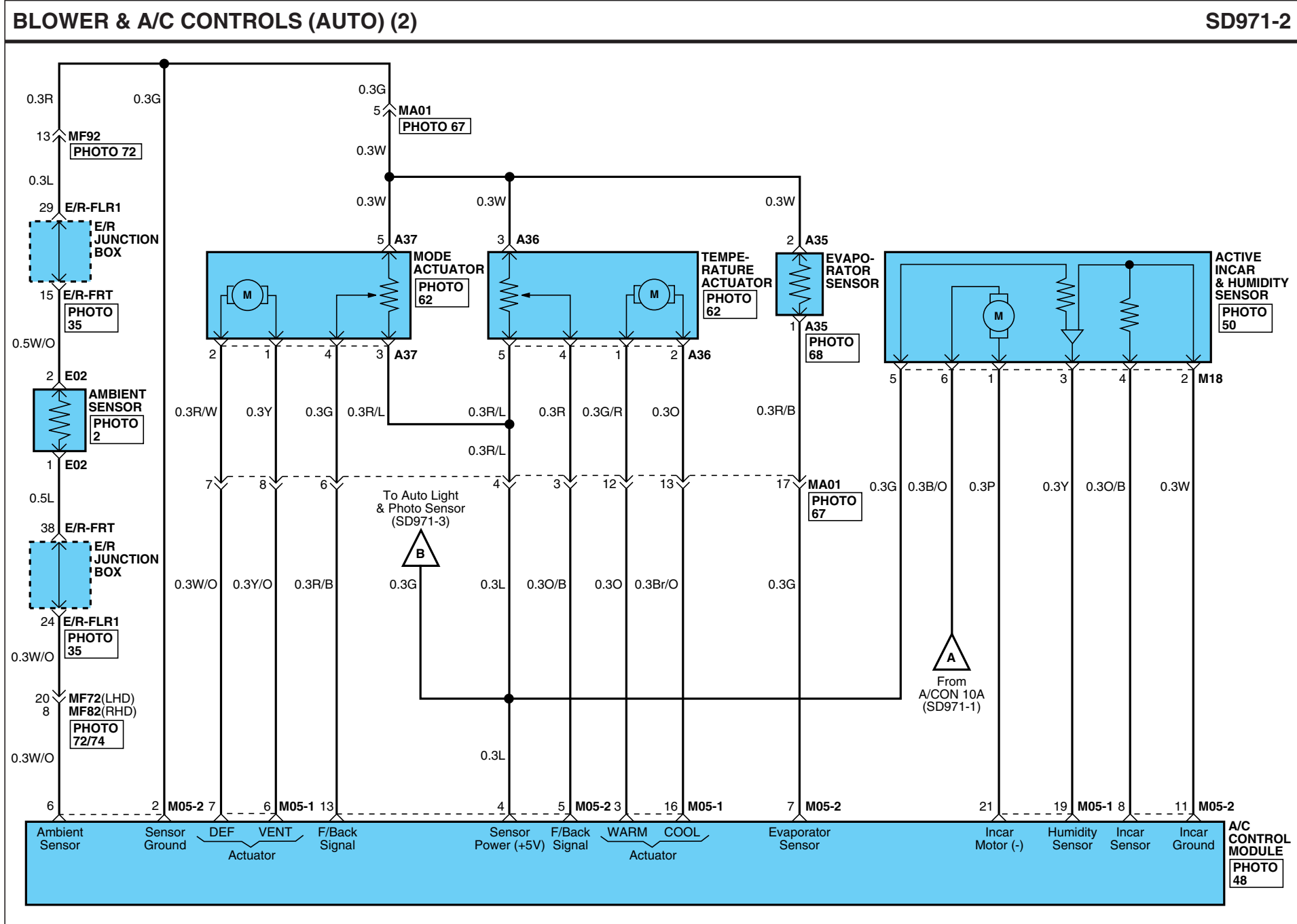

BLOWER & A/C CONTROLS

BLOWER & A/C CONTROLS (AUTO) (3)

SD971-3

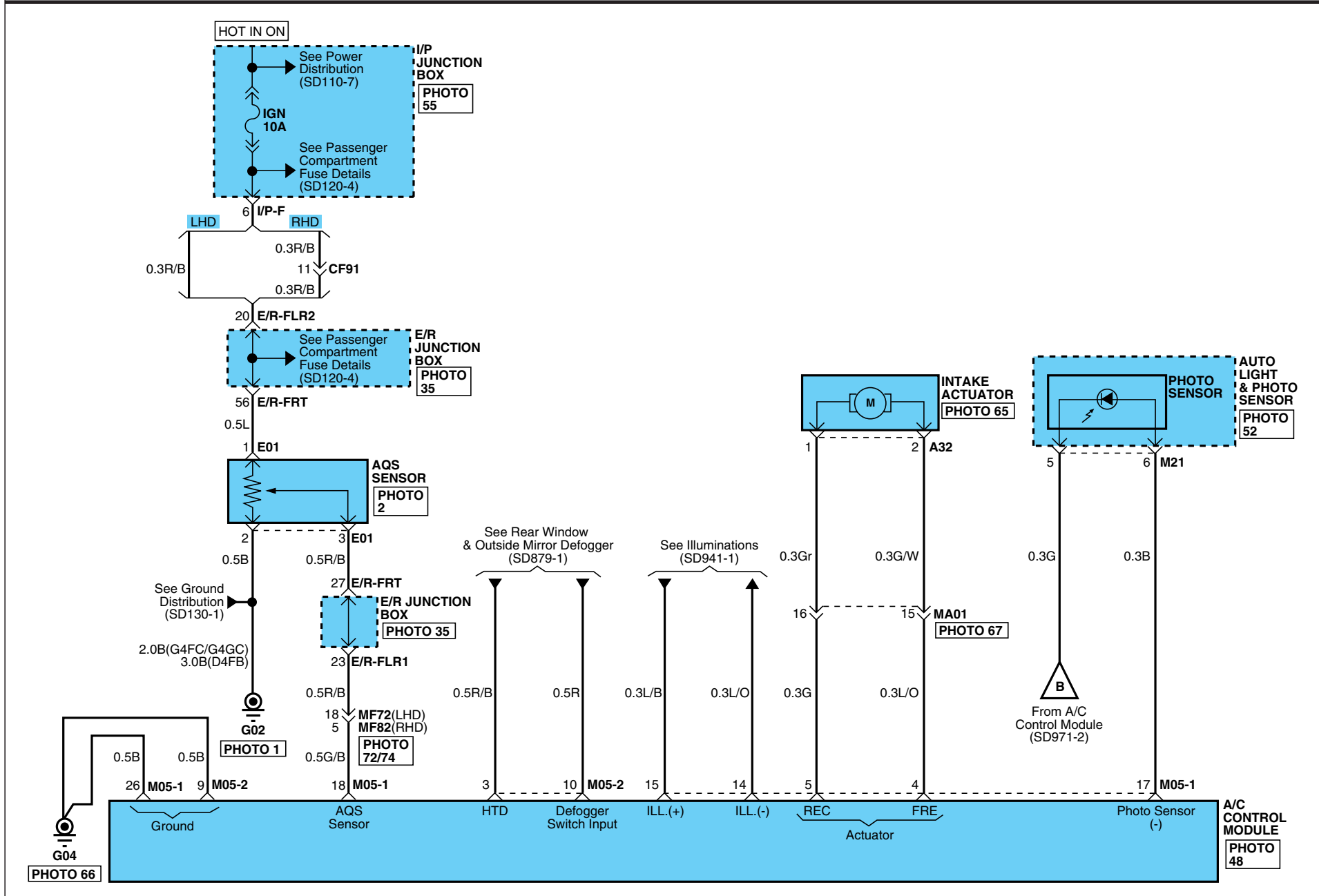



BLOWER & A/C CONTROLS

BLOWER & A/C CONTROLS (AUTO) (4)

SD971-4

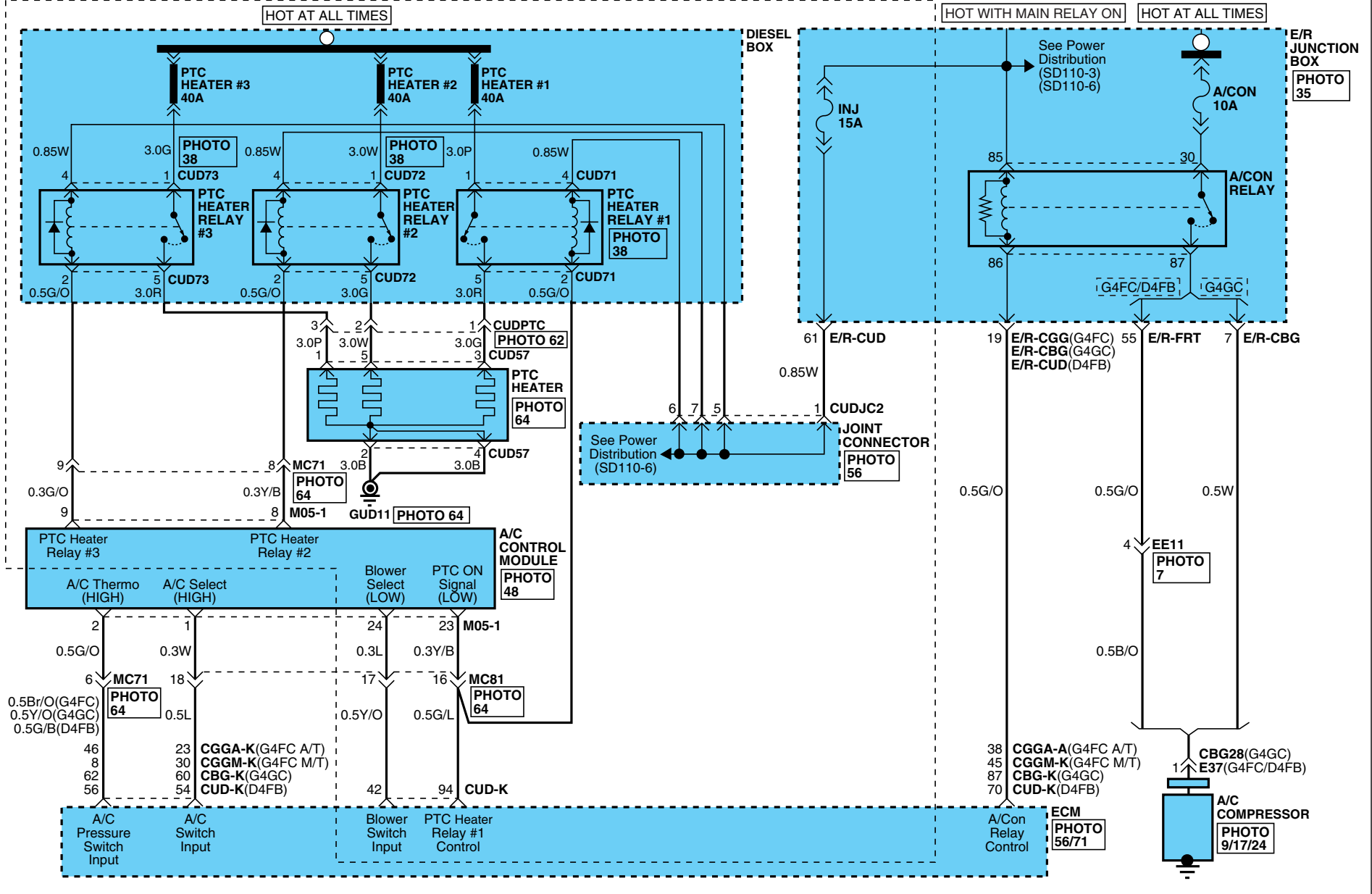

D4FB ONLY



**BLOWER & A/C CONTROLS**

**BLOWER & A/C CONTROLS (AUTO) (5)**

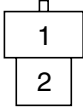
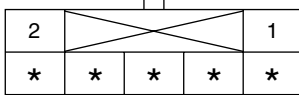
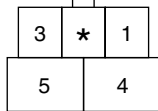
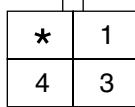
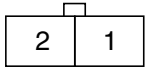
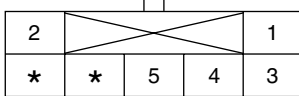
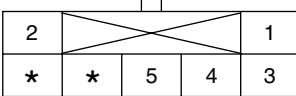
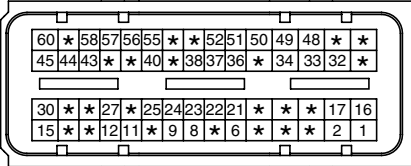
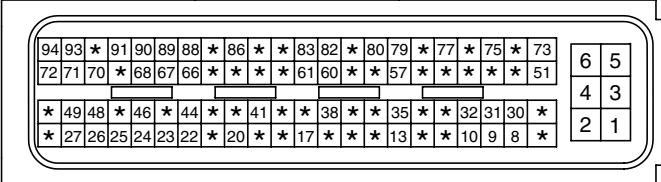
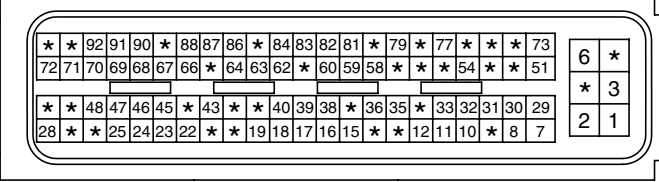
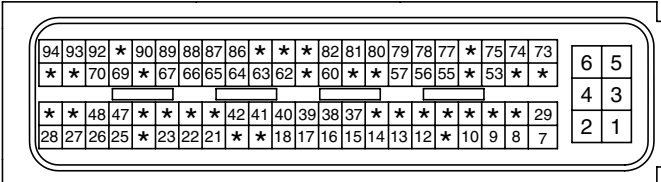
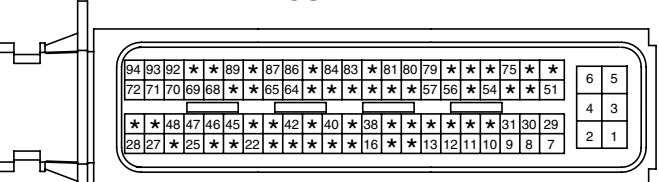
**SD971-5**

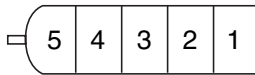
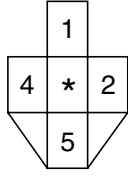
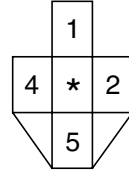
<p><b>A31</b></p>  <p style="text-align: right; font-size: small;">CR02F012</p>	<p><b>A32</b></p>  <p style="text-align: right; font-size: small;">CR07F011</p>	<p><b>A33</b></p>  <p style="text-align: right; font-size: small;">CR05F003</p>	<p><b>A34</b></p>  <p style="text-align: right; font-size: small;">CR04F001</p>
<p><b>A35</b></p>  <p style="text-align: right; font-size: small;">CR02F076</p>	<p><b>A36</b></p>  <p style="text-align: right; font-size: small;">CR07F011</p>	<p><b>A37</b></p>  <p style="text-align: right; font-size: small;">CR07F011</p>	<p><b>CGGA-A</b></p>  <p style="text-align: right; font-size: small;">AMP_ECU_60F_B</p>
<p><b>CGGA-K</b></p>  <p style="text-align: right; font-size: small;">AMP_ECU_94F_B</p>		<p><b>CGGM-K</b></p>  <p style="text-align: right; font-size: small;">AMP_ECU_94F_B</p>	
<p><b>CBG-K</b></p>  <p style="text-align: right; font-size: small;">AMP_ECU_94F_B</p>		<p><b>CUD-K</b></p>  <p style="text-align: right; font-size: small;">AMP_ECU_94F_B</p>	
<p><b>CBG28</b></p>  <p style="text-align: right; font-size: small;">KUM_NMWP_01F_B</p>	<p><b>CUD57</b></p>  <p style="text-align: right; font-size: small;">CR05F047</p>	<p><b>CUD71</b></p>  <p style="text-align: right; font-size: small;">CR05F031</p>	<p><b>CUD72</b></p>  <p style="text-align: right; font-size: small;">CR05F031</p>

**BLOWER & A/C CONTROLS**

**BLOWER & A/C CONTROLS (AUTO) (6)**

**SD971-6**

**CUD73**

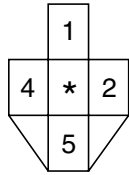

CR05F031

**E01**

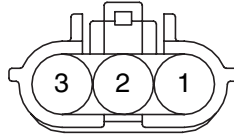

KET\_SWP\_03F\_B

**E02**

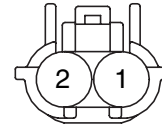

KET\_SWP\_02F\_B

**E37**



KUM\_NMWP\_01F\_B

**M05-1**

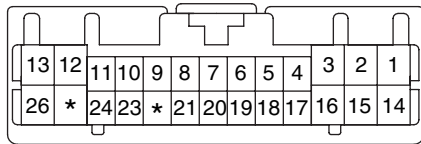

KET\_PCB\_26F

**M05-2**

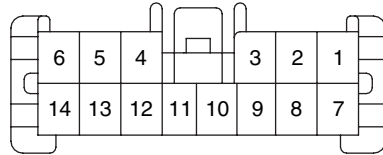

KET\_SDLI1\_14F

**M18**

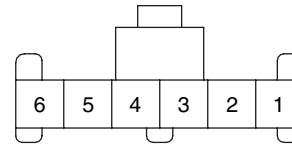

KET\_91A\_06F\_W

**M21**

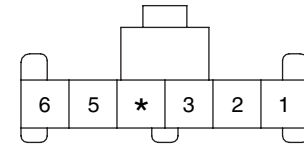

KET\_91A\_06F\_W

BLOWER & A/C CONTROLS (MANUAL) (1)

SD971-7

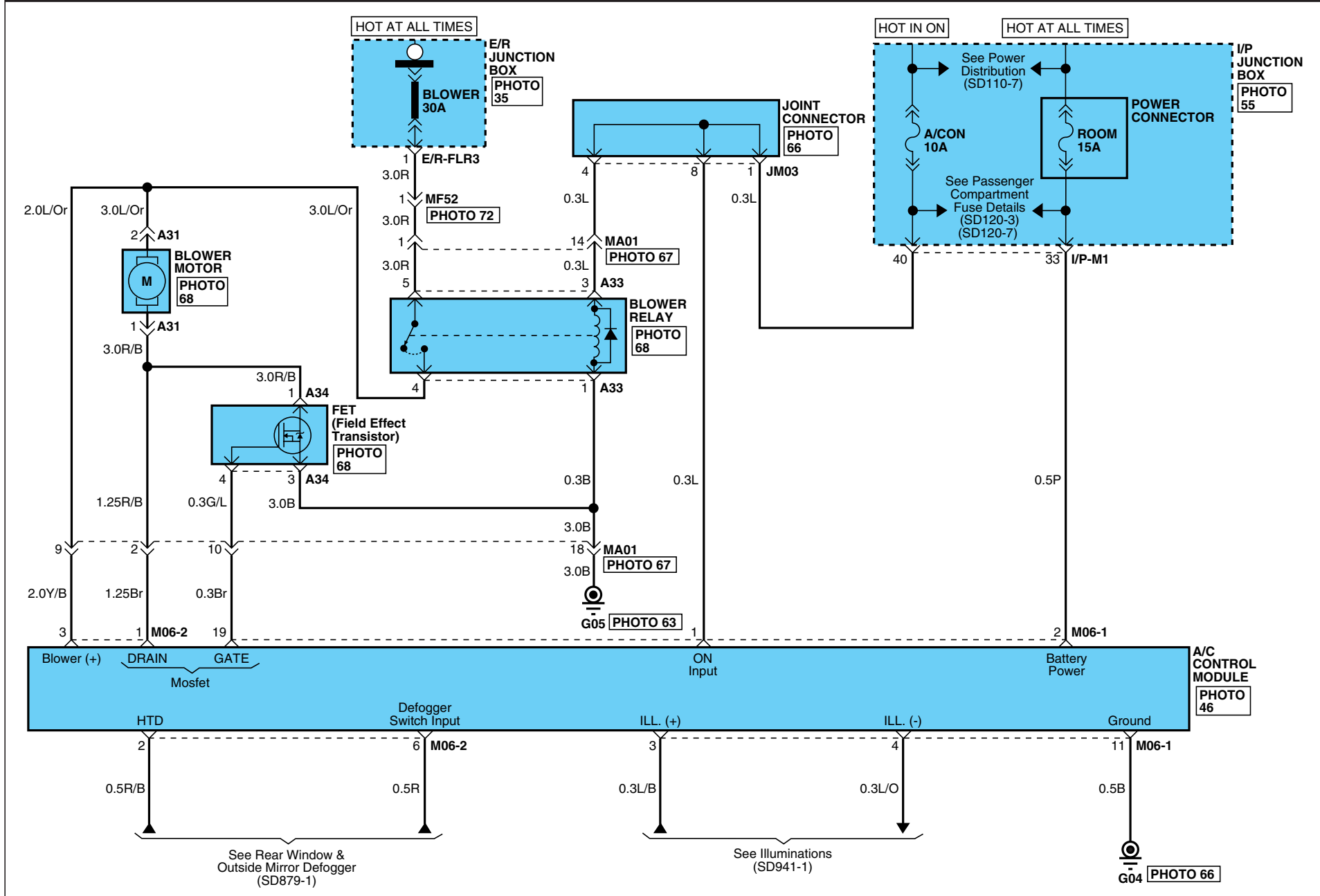

BLOWER & A/C CONTROLS

BLOWER & A/C CONTROLS (MANUAL) (2)

SD971-8

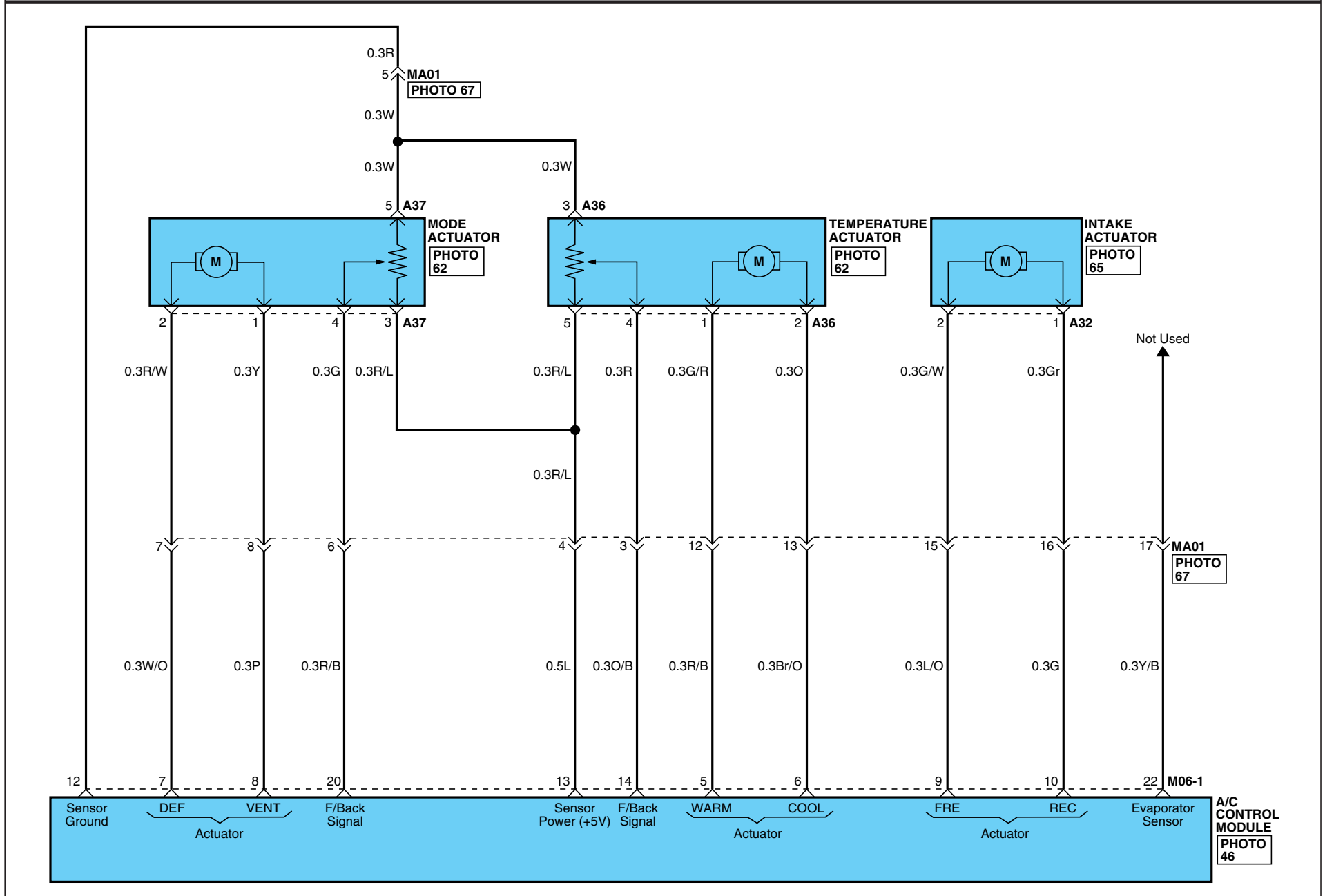

BLOWER & A/C CONTROLS

BLOWER & A/C CONTROLS (MANUAL) (3)

SD971-9

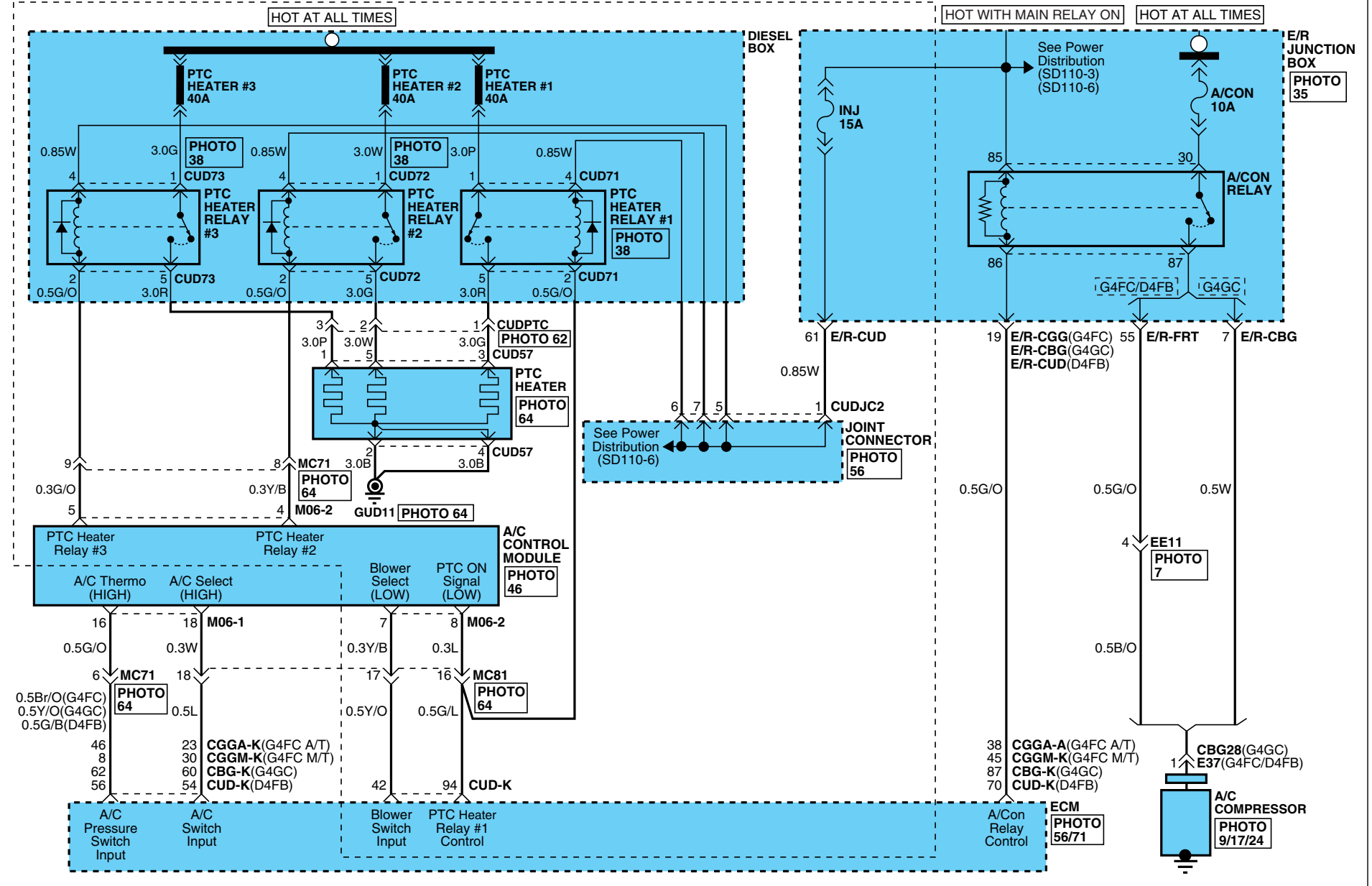

D4FB ONLY



**BLOWER & A/C CONTROLS**

**BLOWER & A/C CONTROLS (MANUAL) (4)**

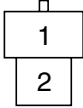
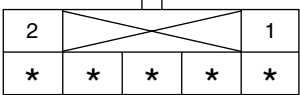
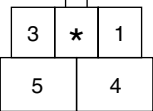
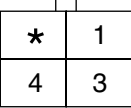
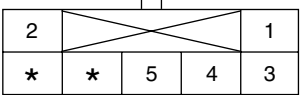
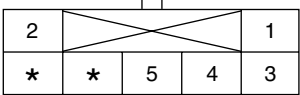
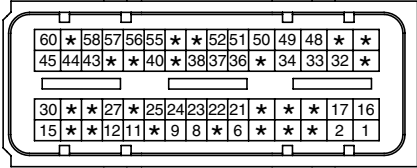
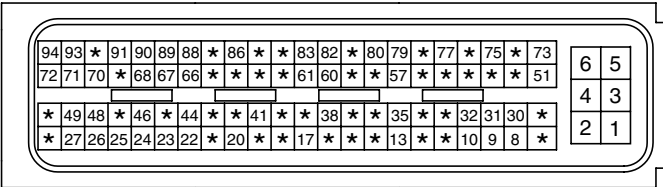
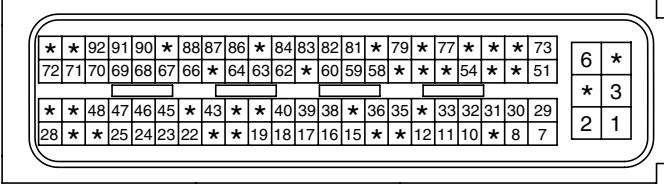
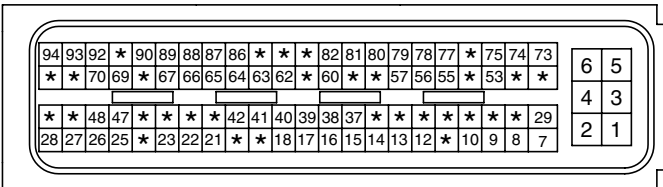
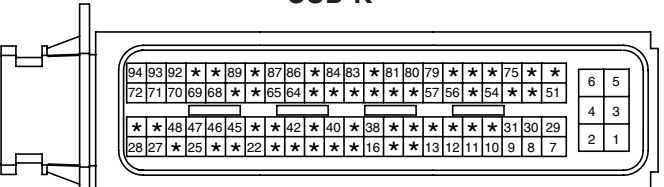
**SD971-10**

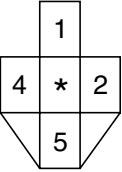
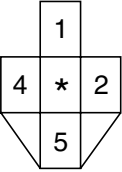
<p><b>A31</b></p>  <p>CR02F012</p>	<p><b>A32</b></p>  <p>CR07F011</p>	<p><b>A33</b></p>  <p>CR05F003</p>	<p><b>A34</b></p>  <p>CR04F001</p>
<p><b>A36</b></p>  <p>CR07F011</p>	<p><b>A37</b></p>  <p>CR07F011</p>	<p><b>CGGA-A</b></p>  <p>AMP_ECU_60F_B</p>	<p><b>BLANK</b></p>
<p><b>CGGA-K</b></p>  <p>AMP_ECU_94F_B</p>		<p><b>CGGM-K</b></p>  <p>AMP_ECU_94F_B</p>	
<p><b>CBG-K</b></p>  <p>AMP_ECU_94F_B</p>		<p><b>CUD-K</b></p>  <p>AMP_ECU_94F_B</p>	
<p><b>CBG28</b></p>  <p>KUM_NMWP_01F_B</p>	<p><b>CUD57</b></p>  <p>CR05F047</p>	<p><b>CUD71</b></p>  <p>CR05F031</p>	<p><b>CUD72</b></p>  <p>CR05F031</p>

**BLOWER & A/C CONTROLS**

**BLOWER & A/C CONTROLS (MANUAL) (5)**

**SD971-11**

**CUD73**

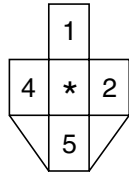

CR05F031

**E37**



KUM\_NMWP\_01F\_B

**M06-1**

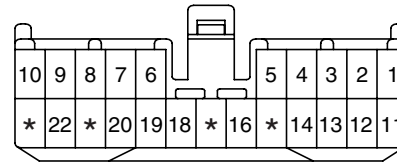

KET\_050\_23F\_W

**M06-2**

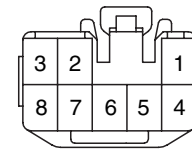

KET\_090II\_08F\_W



**BLOWER & A/C CONTROLS**

**BLOWER & A/C CONTROLS (MANUAL) (6)**

**SD971-12**

**MEMO**

FRONT WIPER & WASHER

EC9ACA0D

FRONT WIPER & WASHER (1)

SD981-1

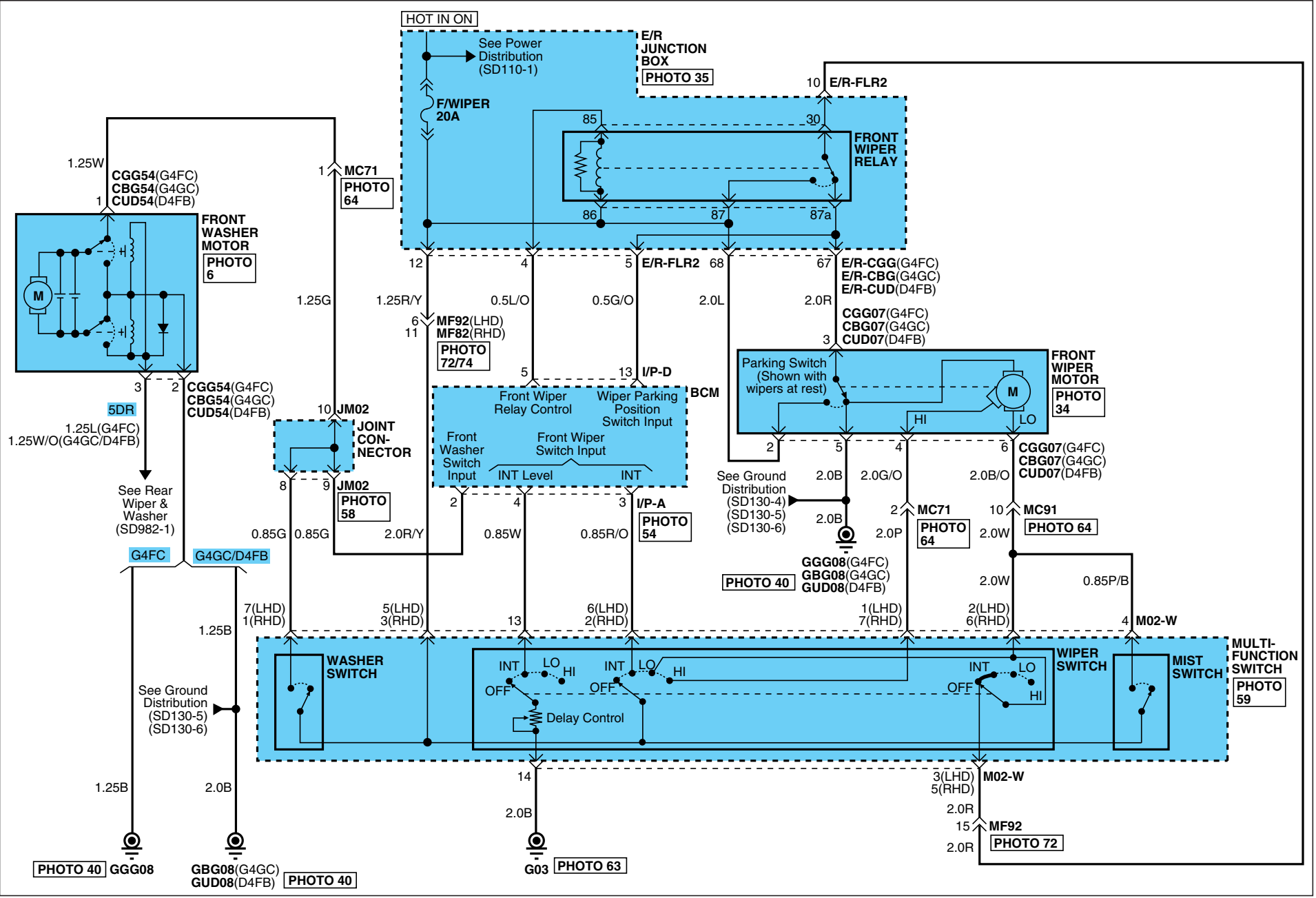

FRONT WIPER & WASHER

FRONT WIPER & WASHER (2)

SD981-2

CGG07



KUM\_NMWP\_06F\_B

CGG54



KET\_090WP\_03F\_Gr

CBG07

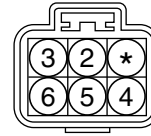

KUM\_NMWP\_06F\_B

CBG54



KET\_090WP\_03F\_GY

CUD07

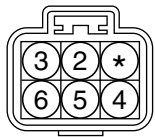

KUM\_NMWP\_06F\_B

CUD54



KET\_090WP\_03F\_GY

I/P-A

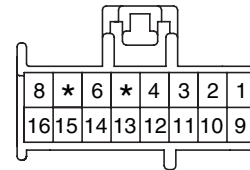

PKD\_ASM\_16F\_B

I/P-D

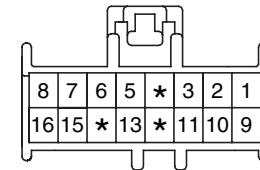

PKD\_ASM\_16F\_G

M02-W

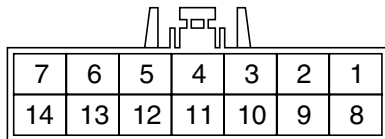

KET090II\_14F\_SW

BLANK

BLANK

BLANK



REAR WIPER & WASHER (1)

SD982-1

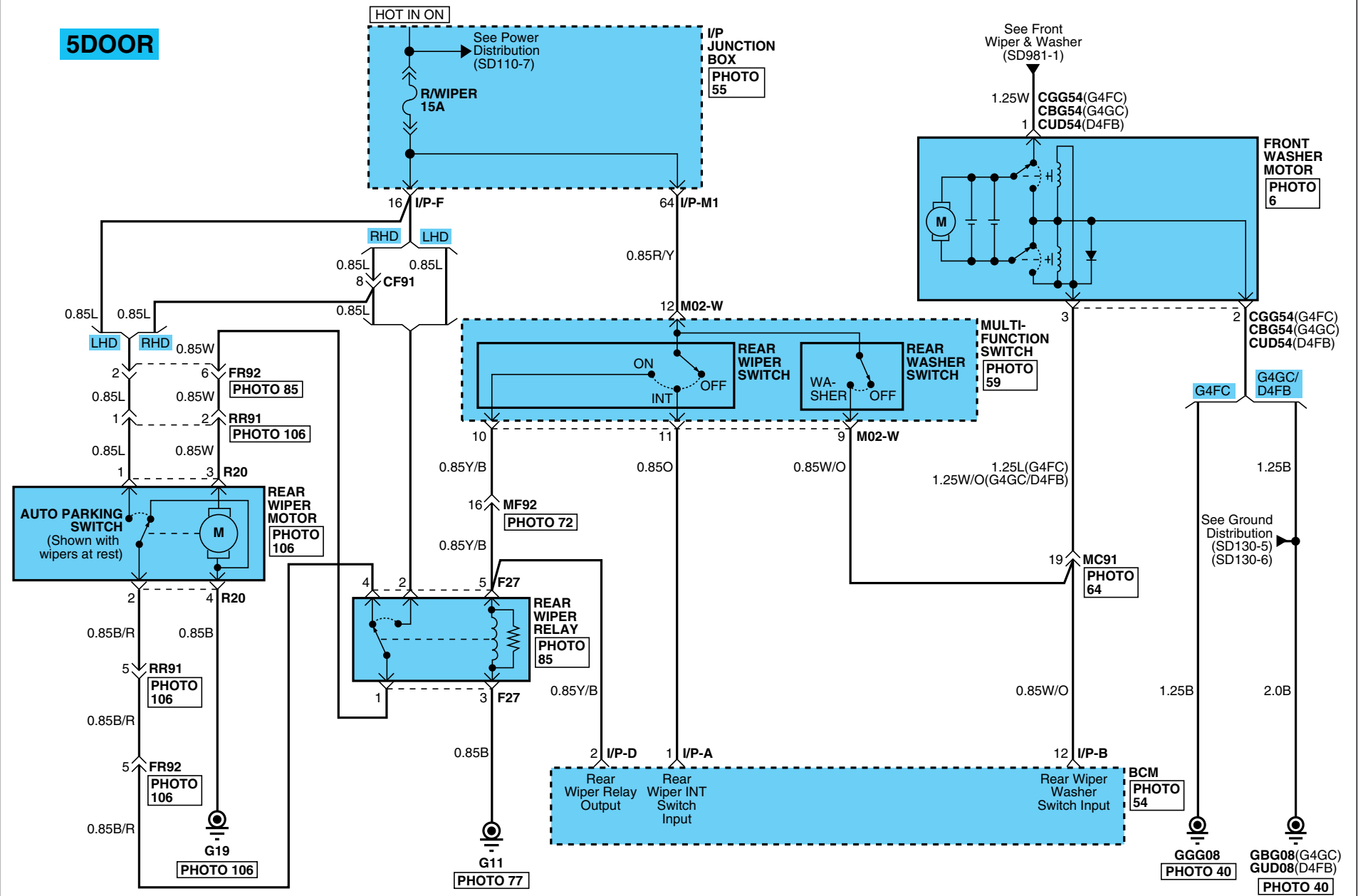
5DOOR

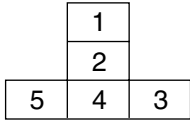
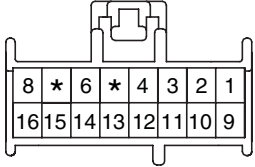
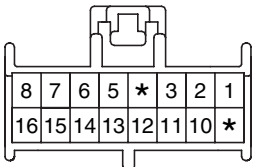
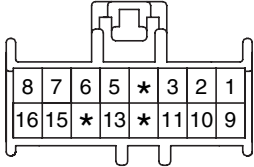
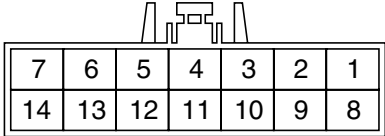
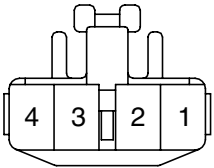

REAR WIPER & WASHER

REAR WIPER & WASHER (2)			SD982-2
<p><b>CGG54</b></p>  <p>KET_090WP_03F_Gr</p>	<p><b>CBG54</b></p>  <p>KET_090WP_03F_GY</p>	<p><b>CUD54</b></p>  <p>KET_090WP_03F_GY</p>	<p><b>F27</b></p>  <p>KET_RELAY_CONN_B</p>
<p><b>I/P-A</b></p>  <p>PKD_ASM_16F_B</p>	<p><b>I/P-B</b></p>  <p>PKD_ASM_16F_GR</p>	<p><b>I/P-D</b></p>  <p>PKD_ASM_16F_G</p>	<p><b>M02-W</b></p>  <p>KET090II_14F_SW</p>
<p><b>R20</b></p>  <p>KET_090II_4F_N</p>	<p><b>BLANK</b></p>	<p><b>BLANK</b></p>	<p><b>BLANK</b></p>

COMPONENT LOCATIONS EAAFAFDB

COMPONENT LOCATIONS(1)

CL-1

PHOTO.1

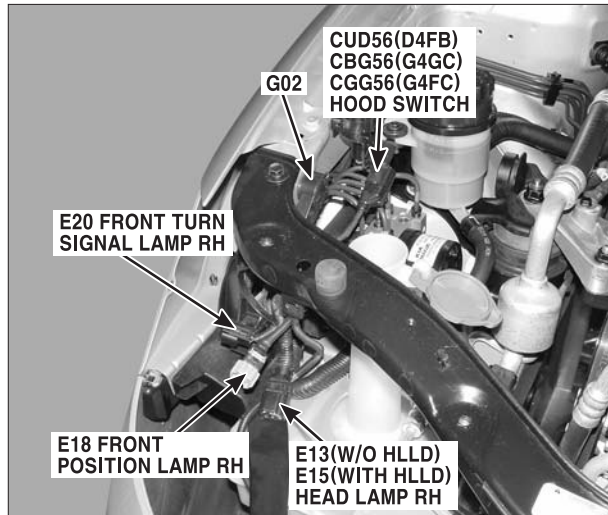

PHOTO.2

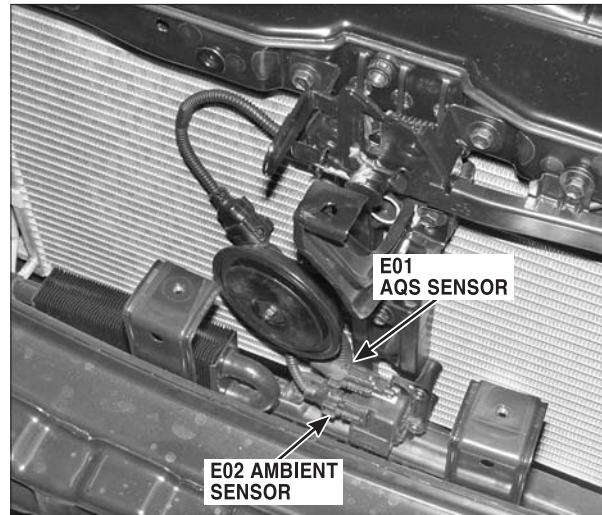

PHOTO.3

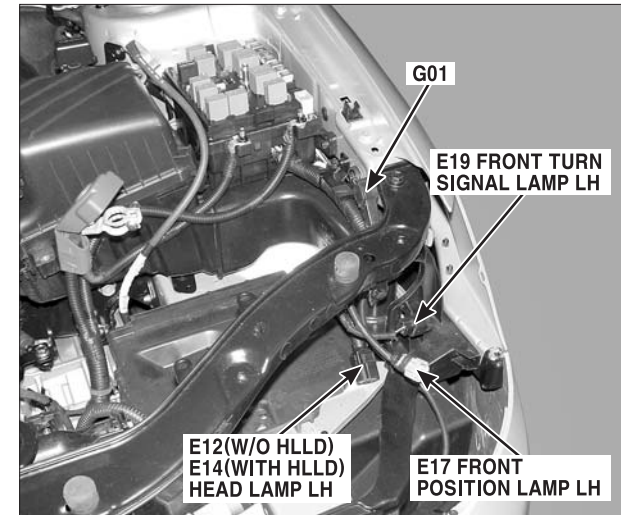

PHOTO.4

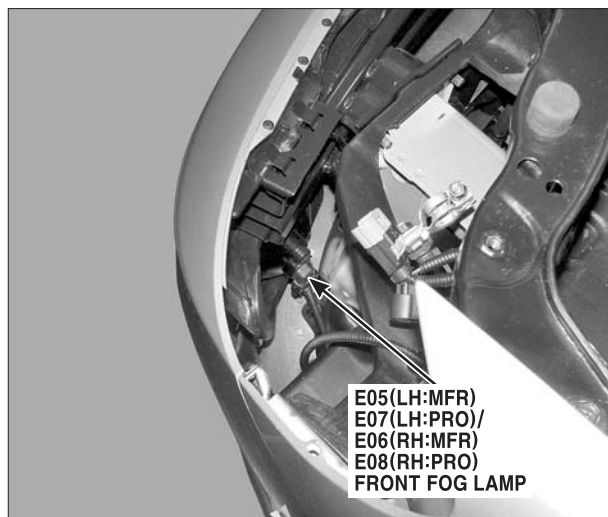

PHOTO.5

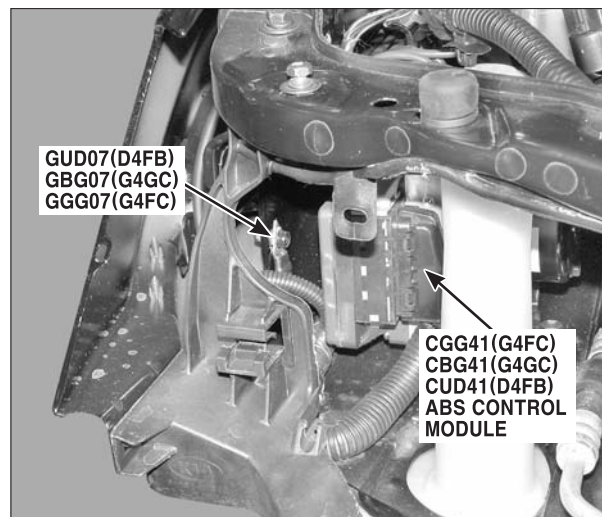
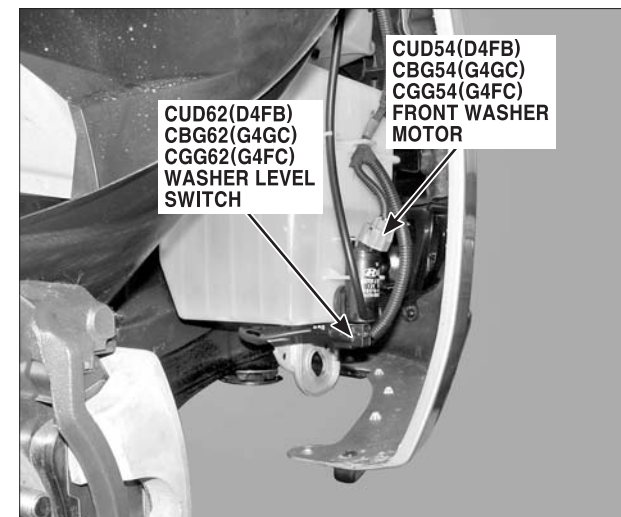

PHOTO.6





COMPONENT LOCATIONS

COMPONENT LOCATIONS(2)

CL-2

PHOTO.7

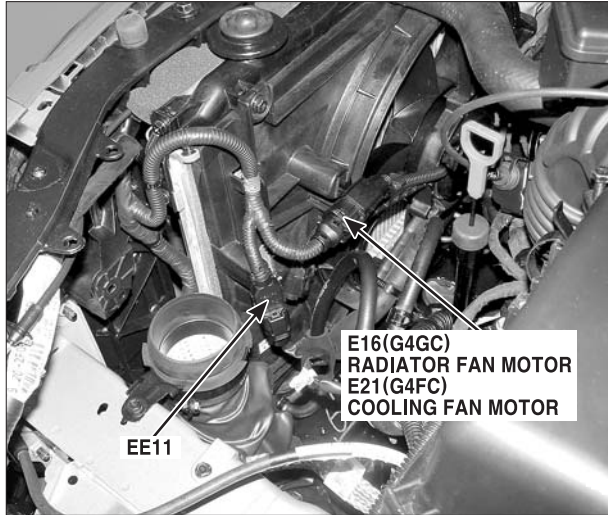

PHOTO.8

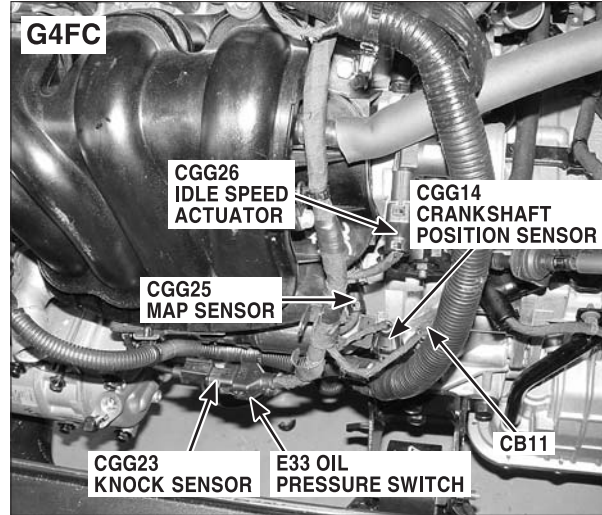

PHOTO.9

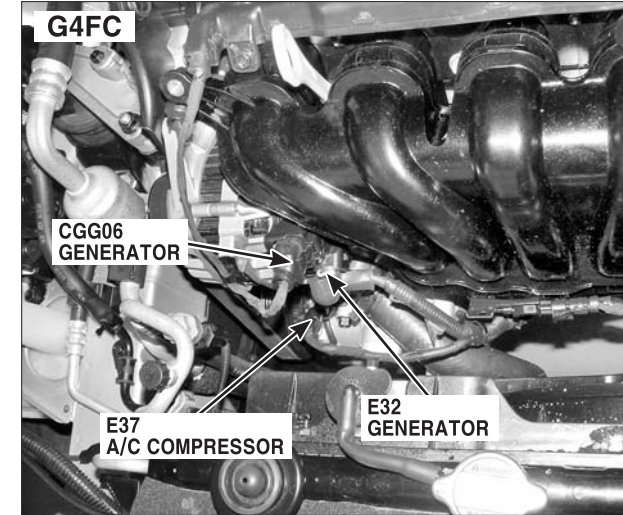

PHOTO.10

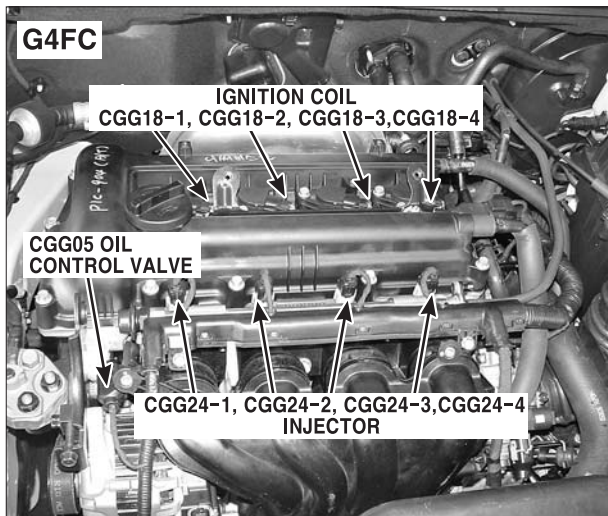

PHOTO.11

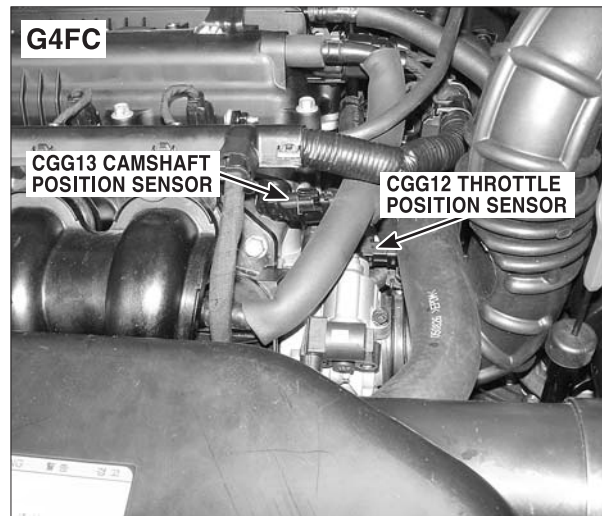
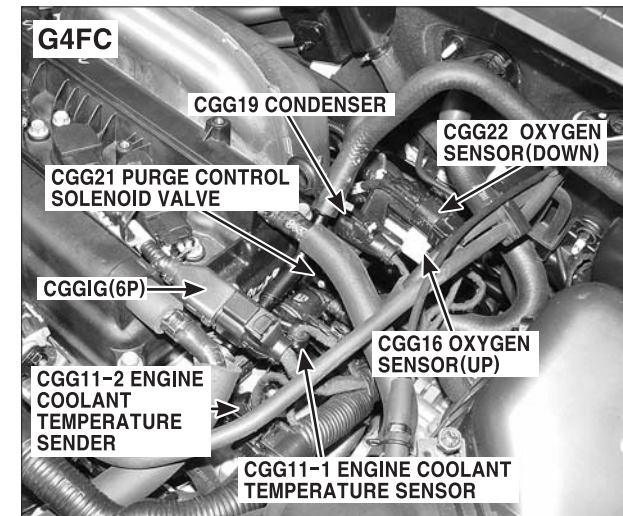

PHOTO.12





COMPONENT LOCATIONS

COMPONENT LOCATIONS(3)

CL-3

PHOTO.13

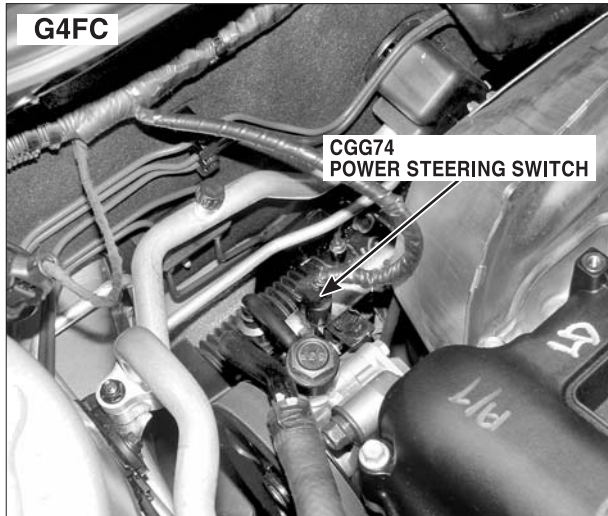

PHOTO.14

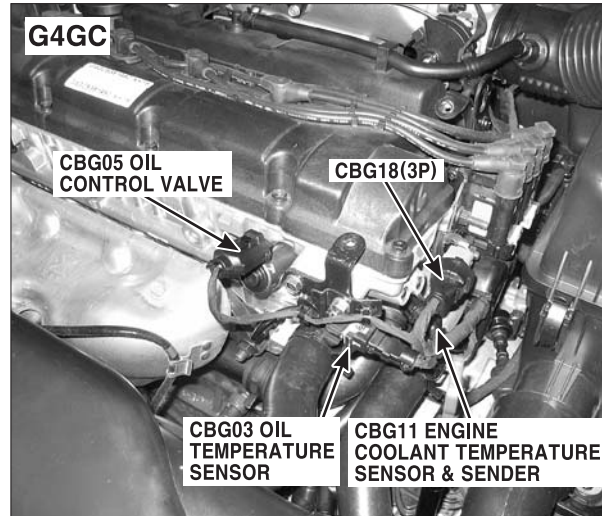

PHOTO.15

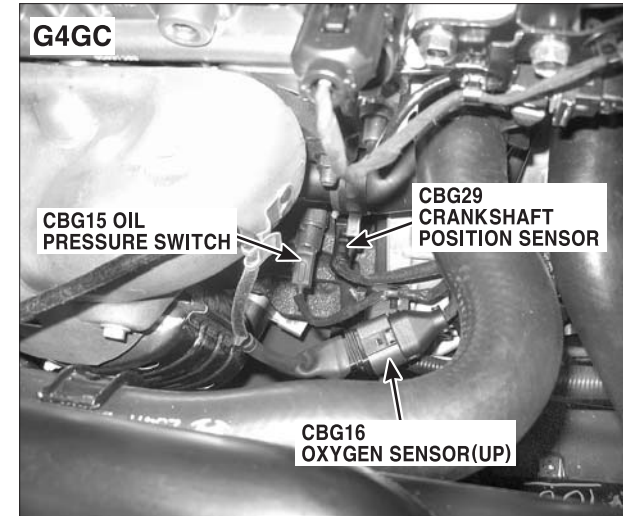

PHOTO.16

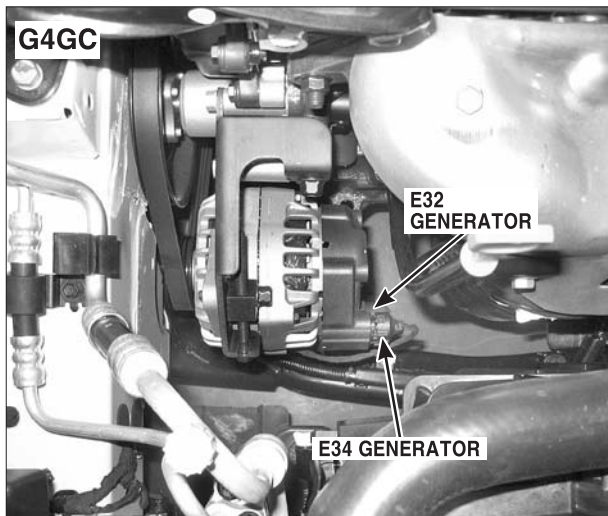

PHOTO.17

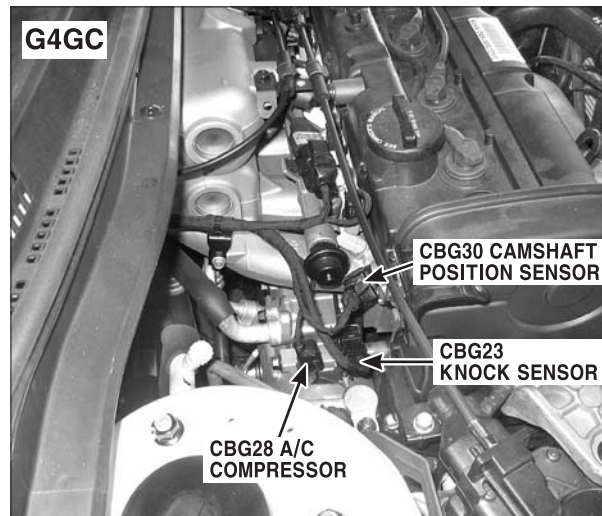
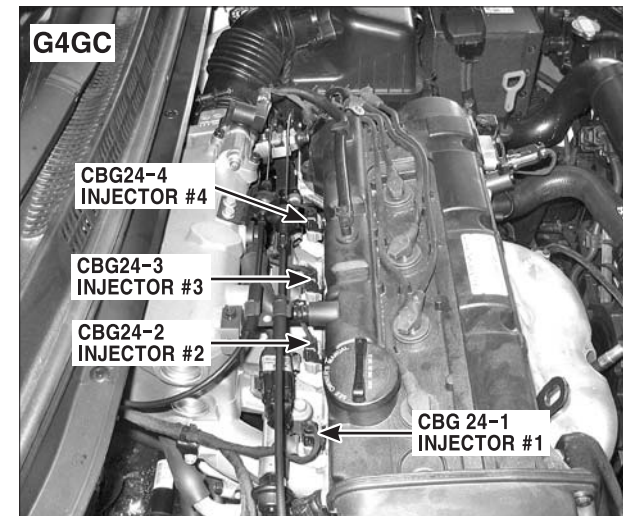

PHOTO.18





COMPONENT LOCATIONS

COMPONENT LOCATIONS(4)

CL-4

PHOTO.19

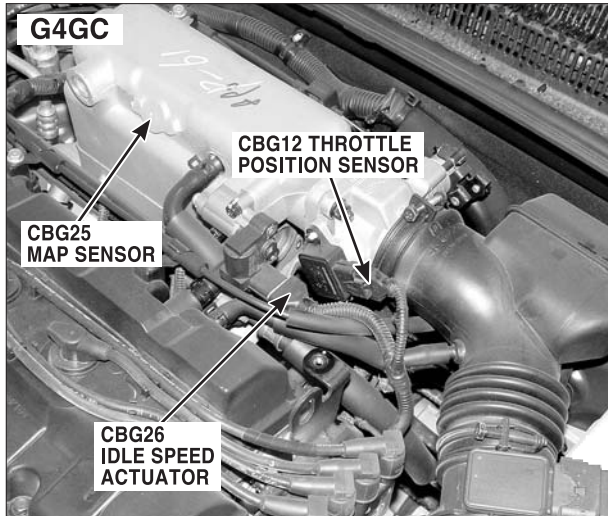

PHOTO.20

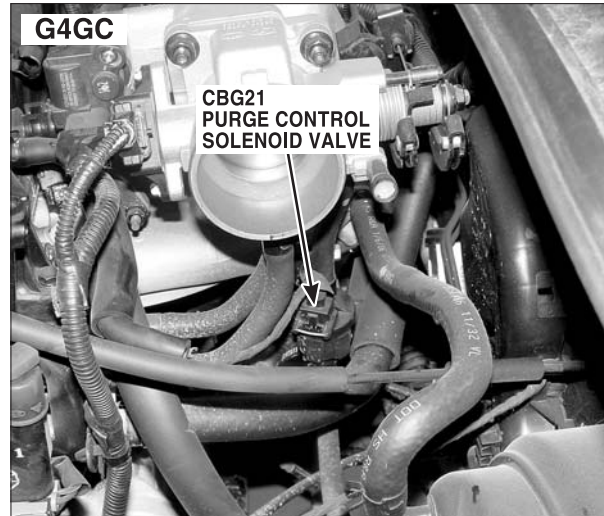

PHOTO.21

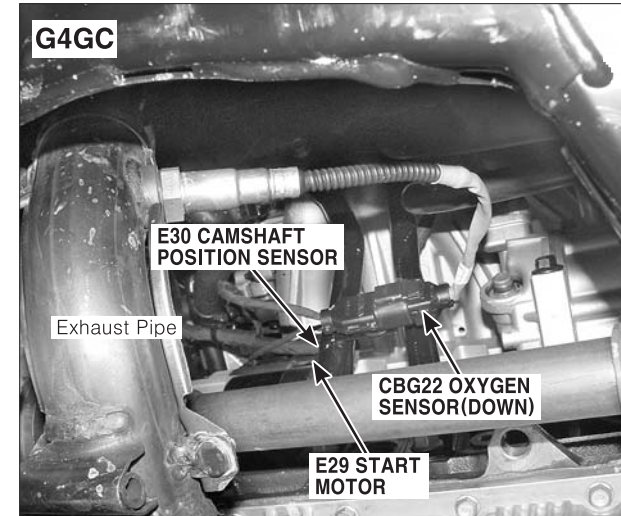

PHOTO.22

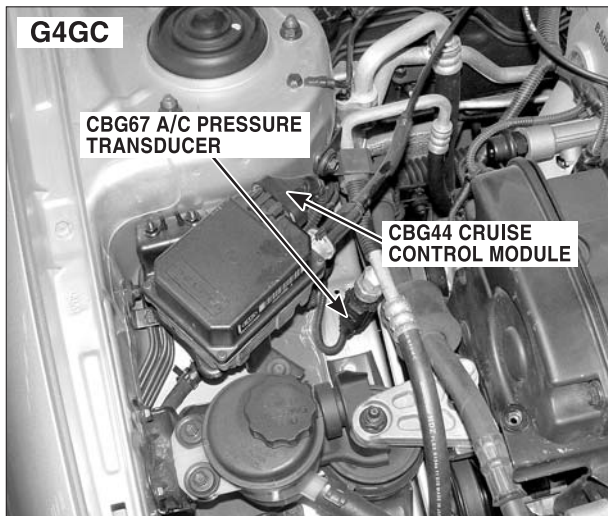

PHOTO.23

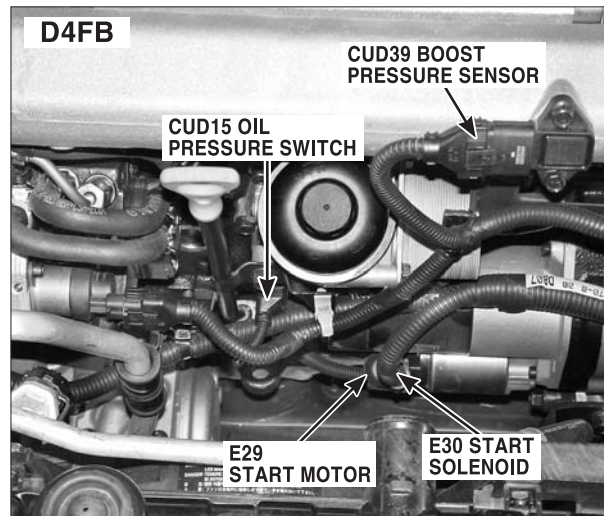
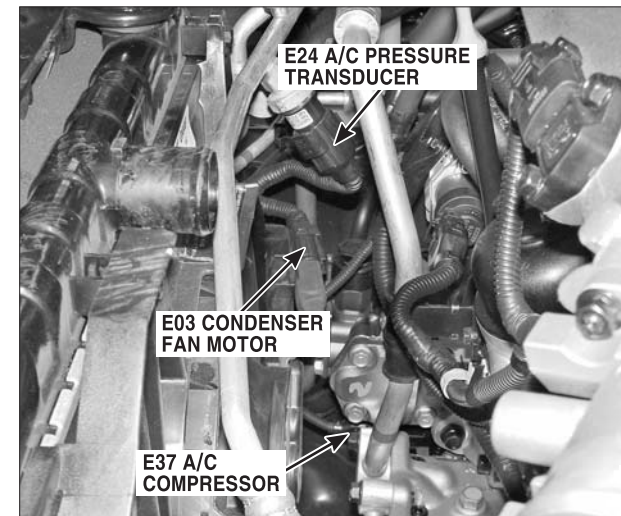

PHOTO.24





COMPONENT LOCATIONS

COMPONENT LOCATIONS(5)

CL-5

PHOTO.25

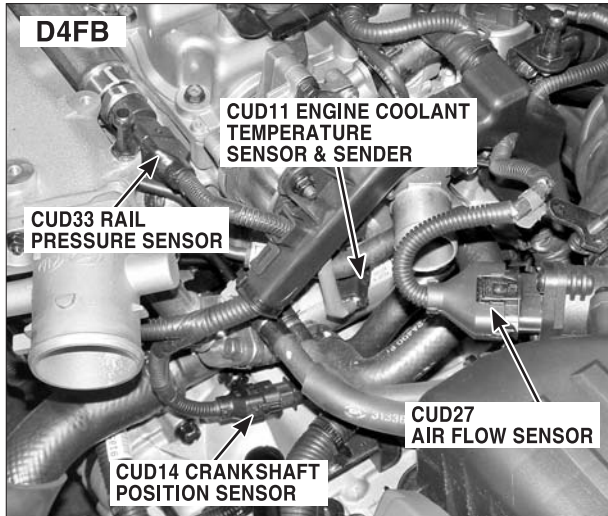

PHOTO.26

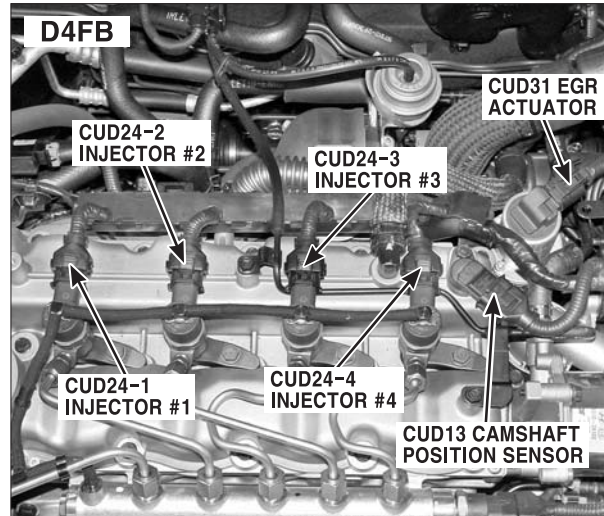

PHOTO.27

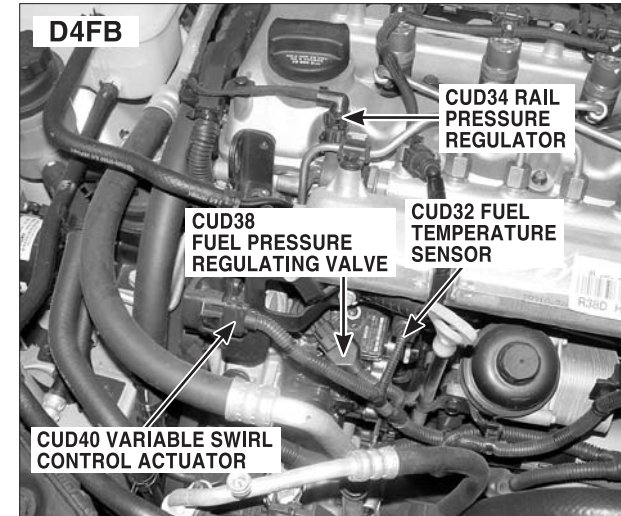

PHOTO.28

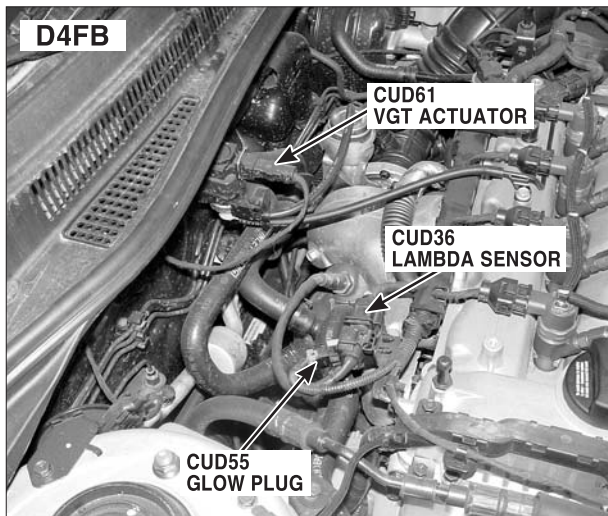

PHOTO.29

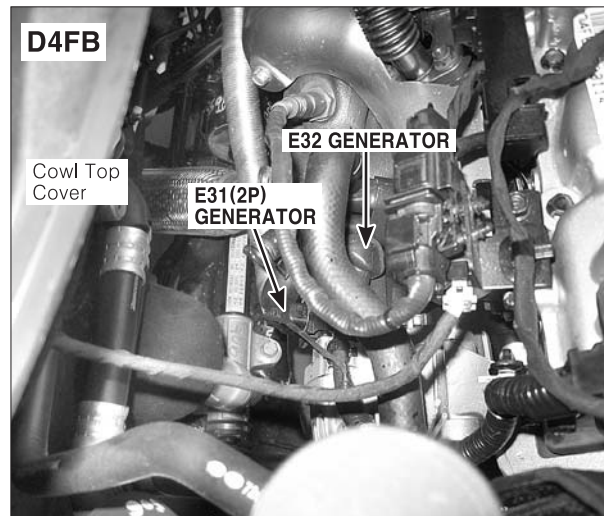
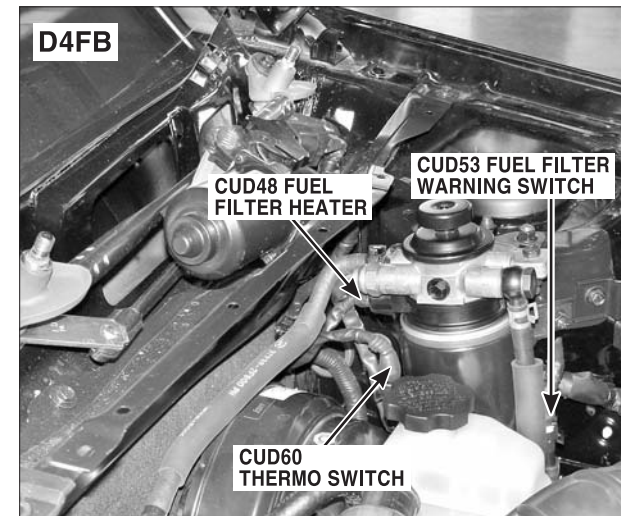

PHOTO.30





COMPONENT LOCATIONS

COMPONENT LOCATIONS(6)

CL-6

PHOTO.31

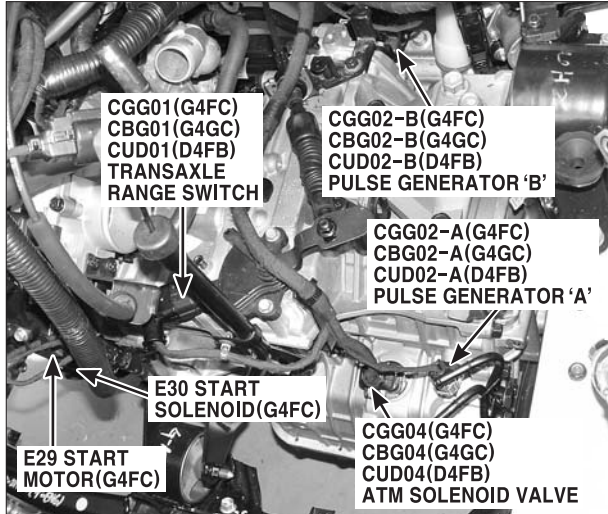

PHOTO.32

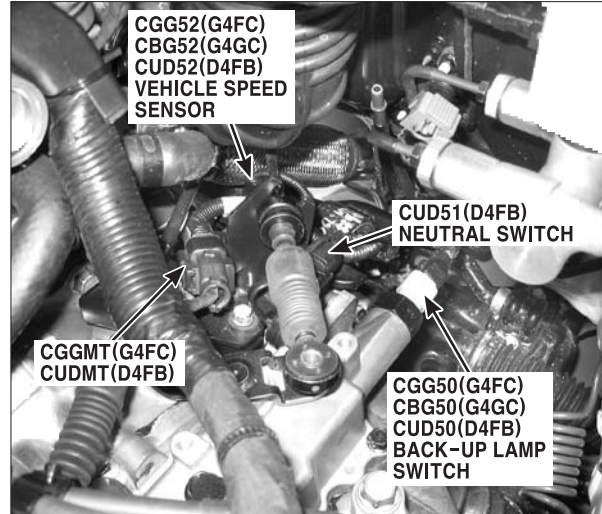

PHOTO.33

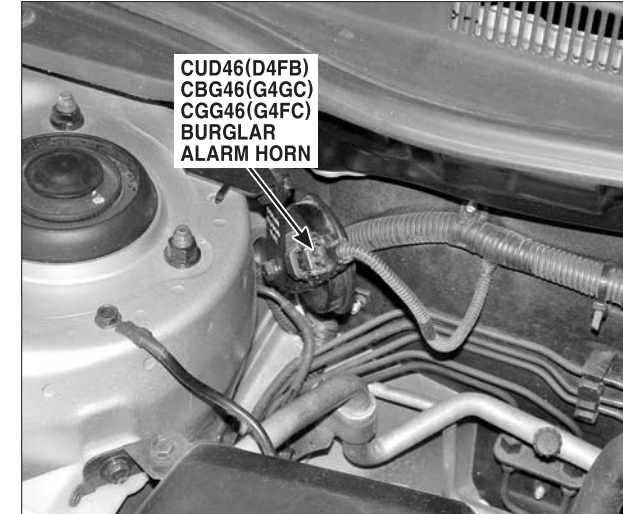

PHOTO.34

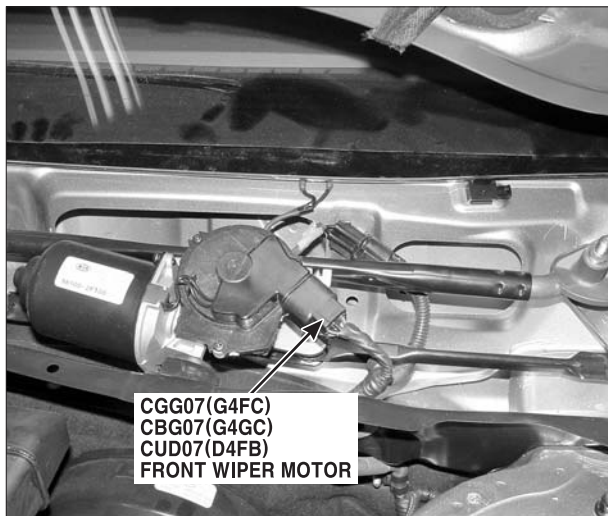

PHOTO.35

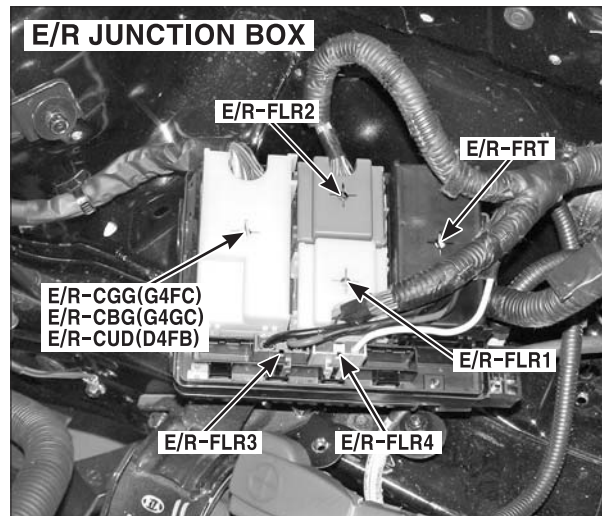
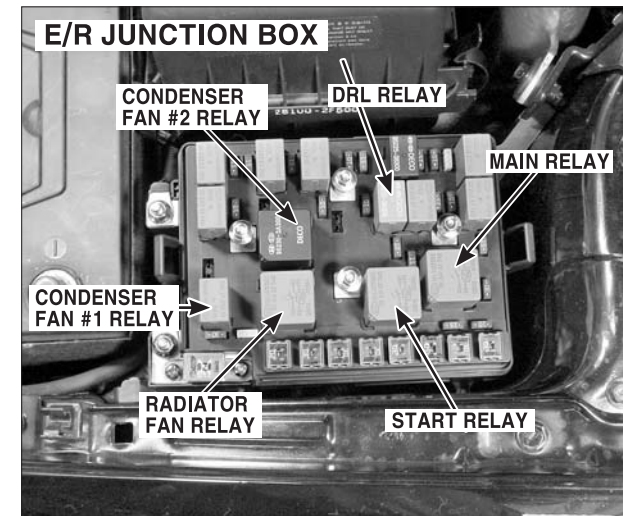

PHOTO.36



COMPONENT LOCATIONS

COMPONENT LOCATIONS(7)

CL-7

PHOTO.37

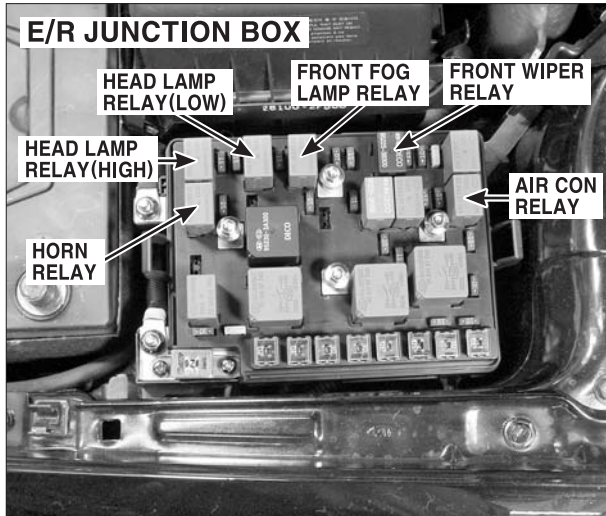

PHOTO.38

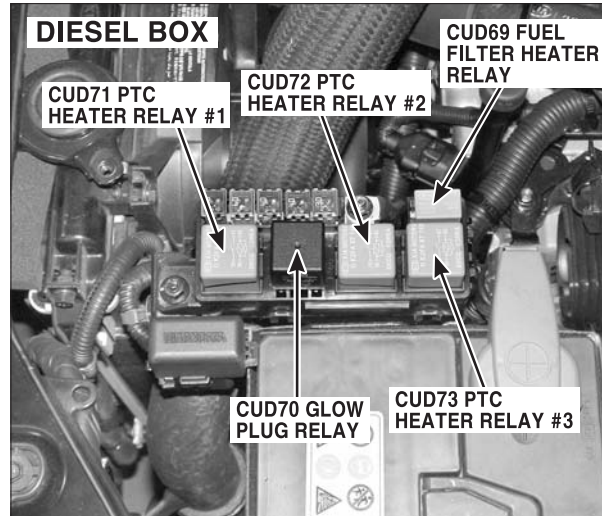

PHOTO.39

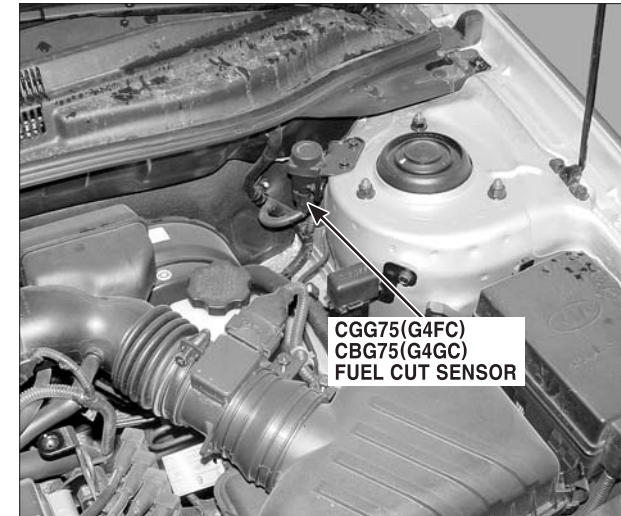

PHOTO.40

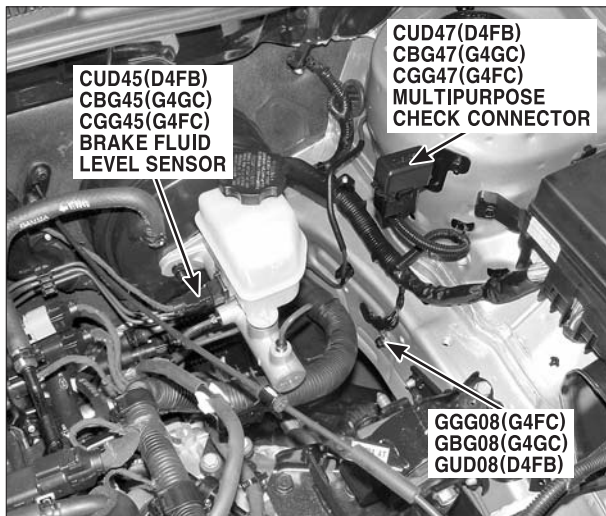

PHOTO.41

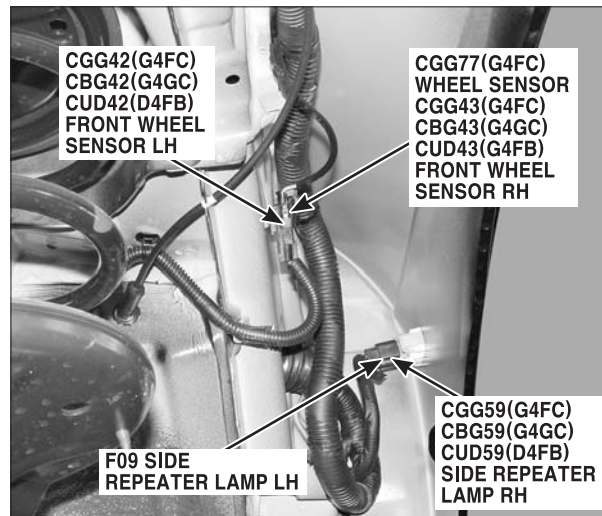
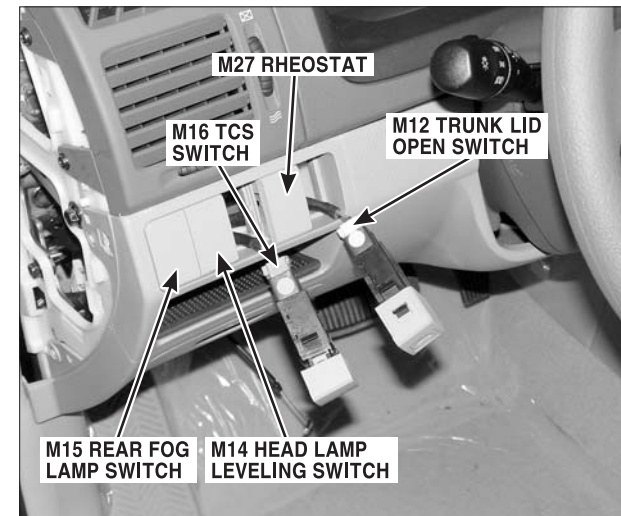

PHOTO.42





COMPONENT LOCATIONS

COMPONENT LOCATIONS(8)

CL-8

PHOTO.43



PHOTO.44



PHOTO.45

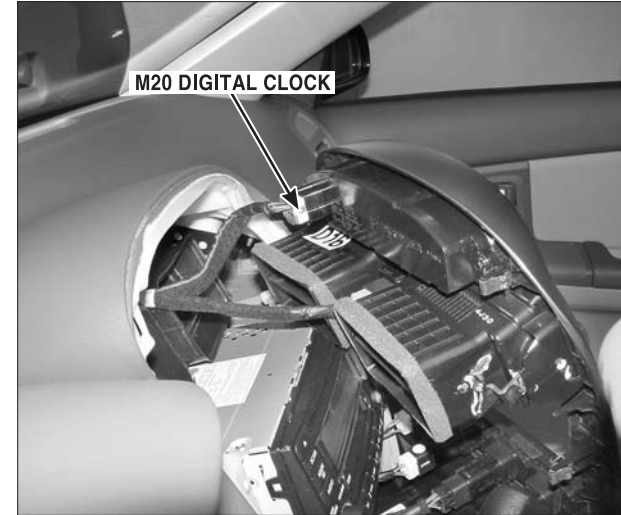

PHOTO.46

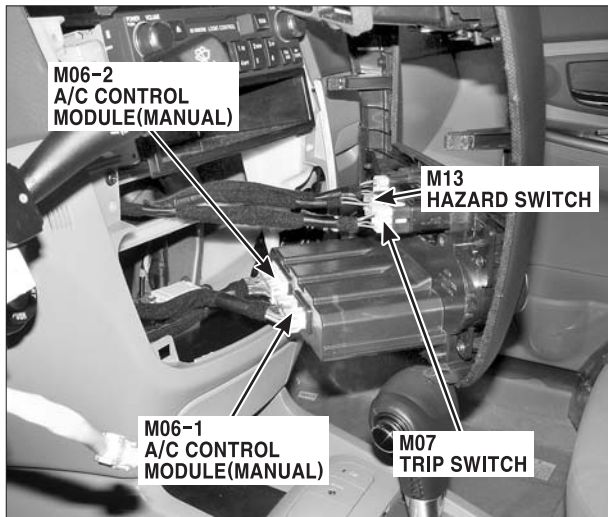

PHOTO.47

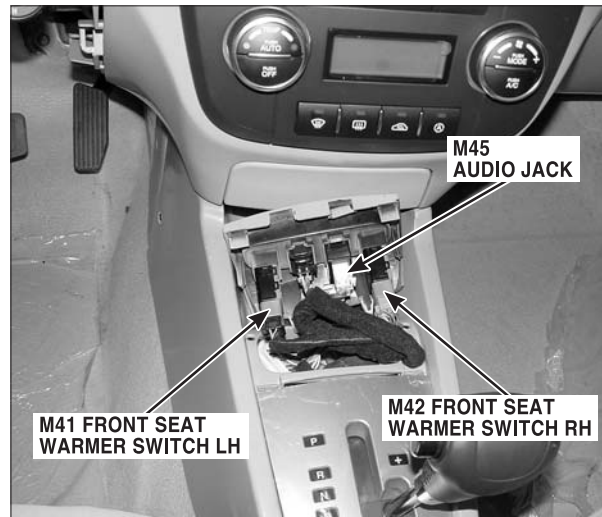
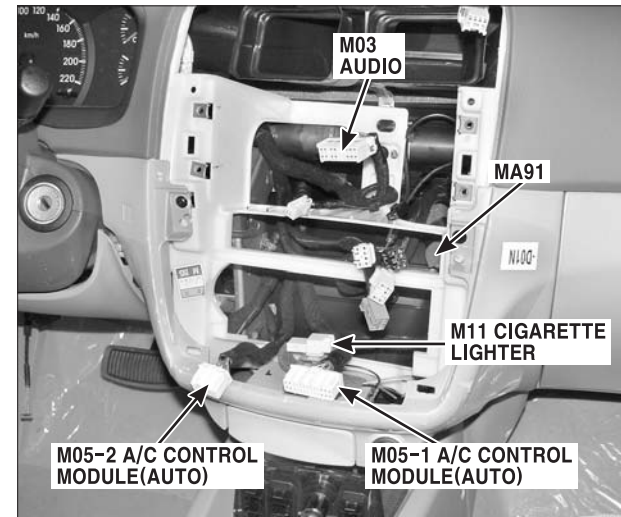

PHOTO.48



COMPONENT LOCATIONS

COMPONENT LOCATIONS(9)

CL-9

PHOTO.49



PHOTO.50

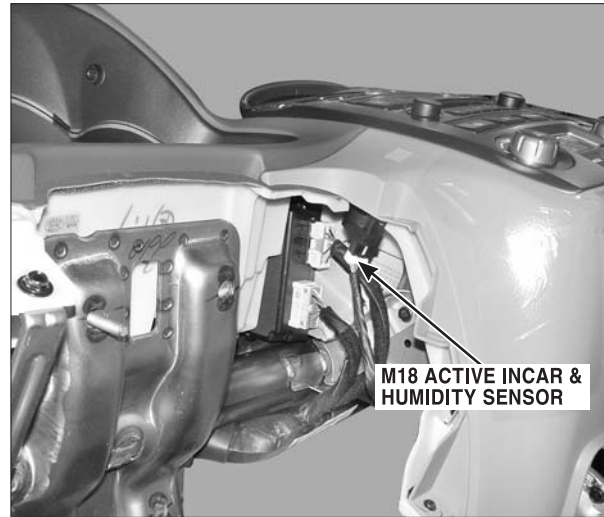

PHOTO.51



PHOTO.52

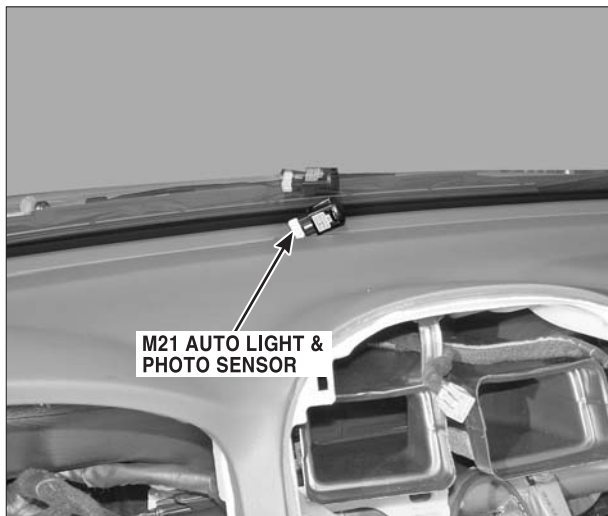

PHOTO.53

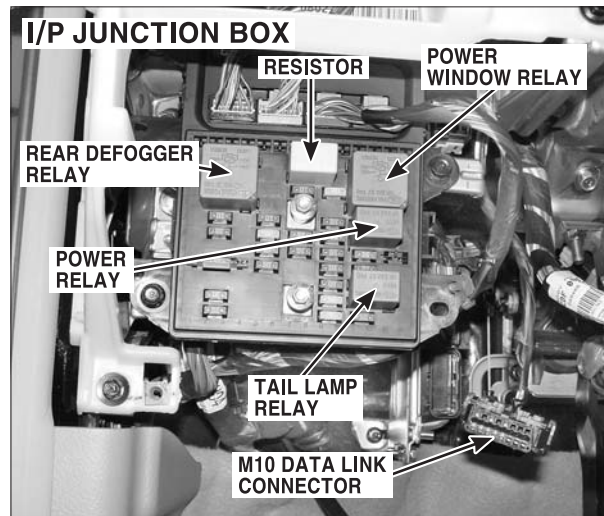
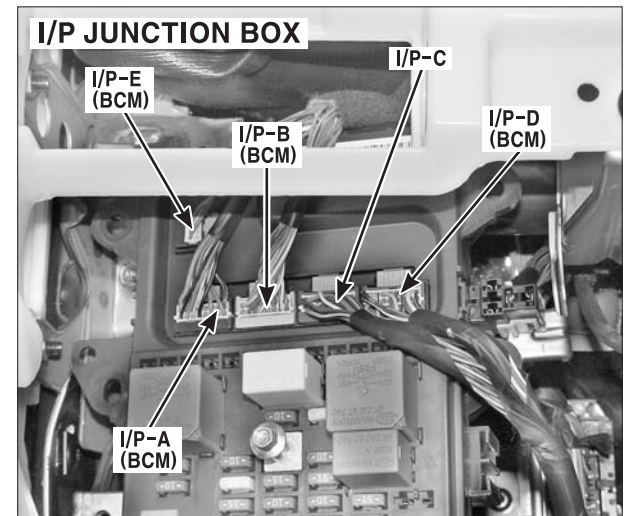

PHOTO.54





COMPONENT LOCATIONS

COMPONENT LOCATIONS(10)

CL-10

PHOTO.55

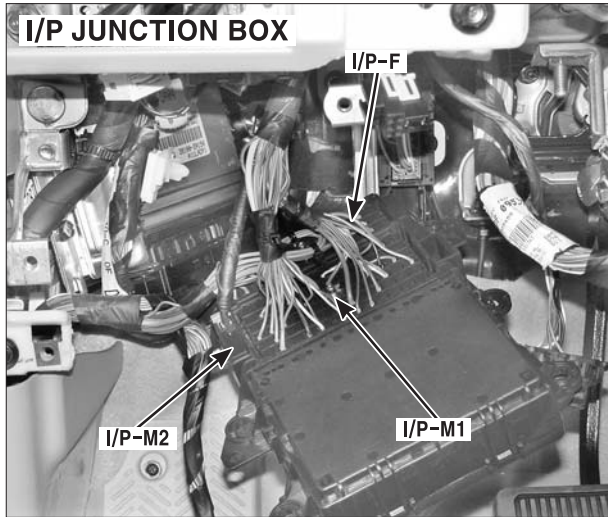

PHOTO.56

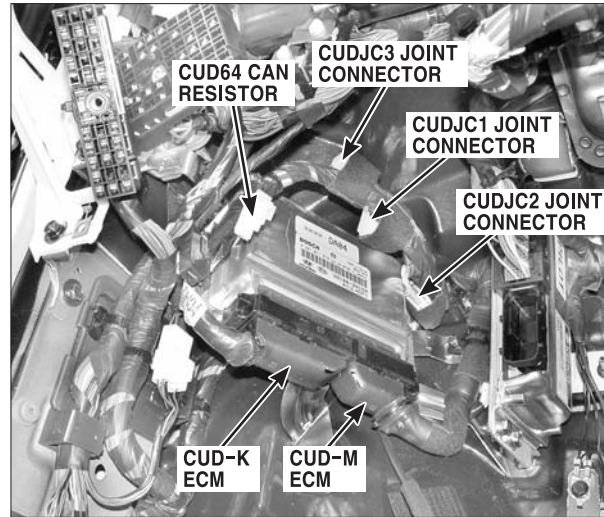

PHOTO.57

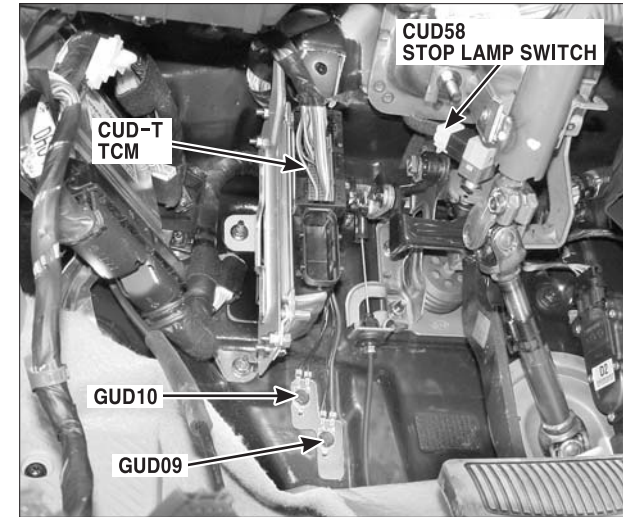

PHOTO.58

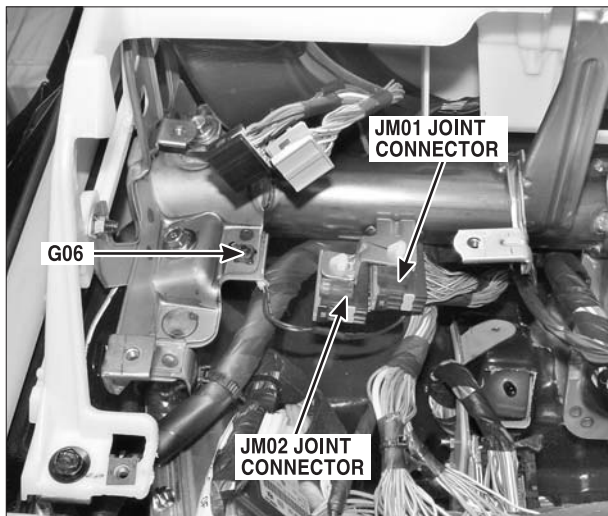

PHOTO.59

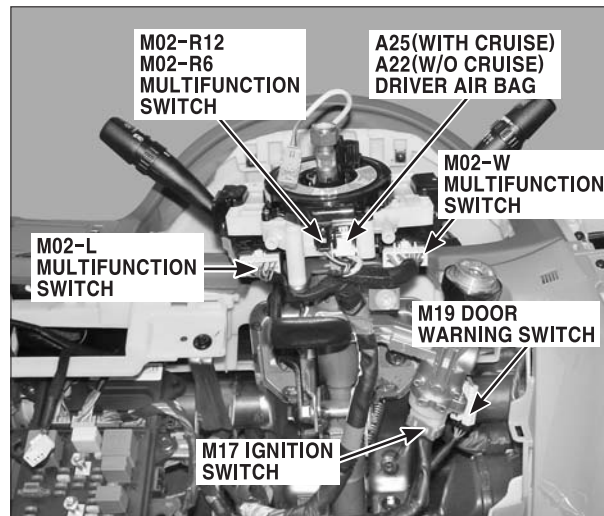

PHOTO.60



COMPONENT LOCATIONS

COMPONENT LOCATIONS(11)

CL-11

PHOTO.61

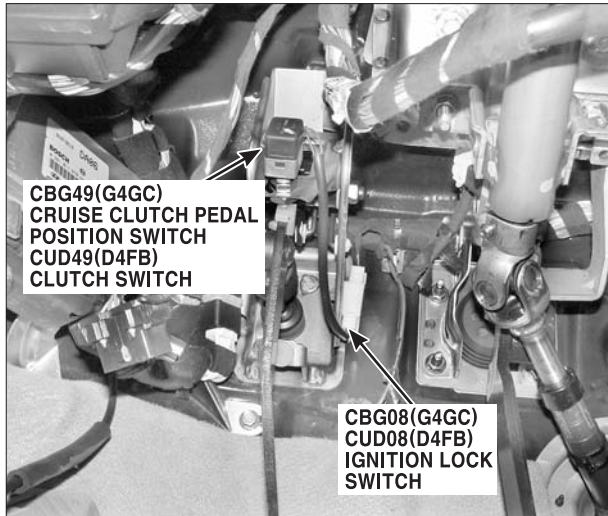

PHOTO.62

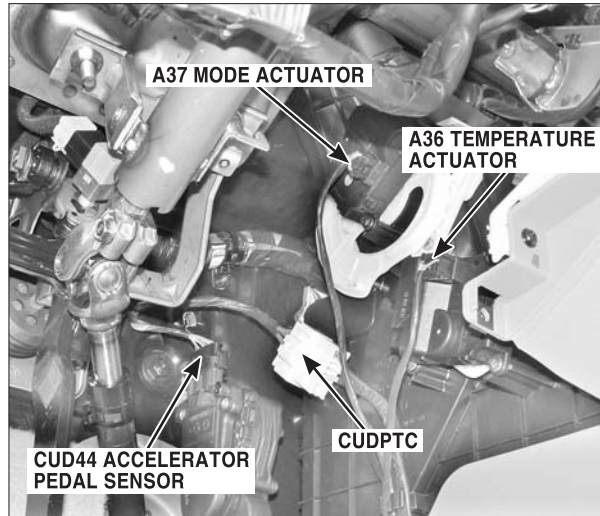

PHOTO.63

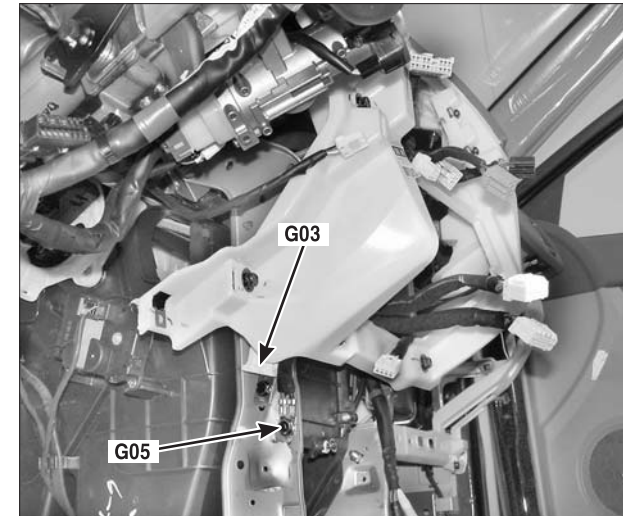

PHOTO.64

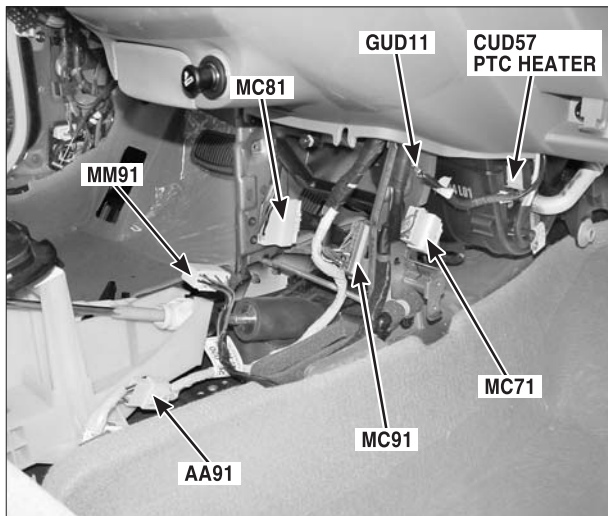

PHOTO.65

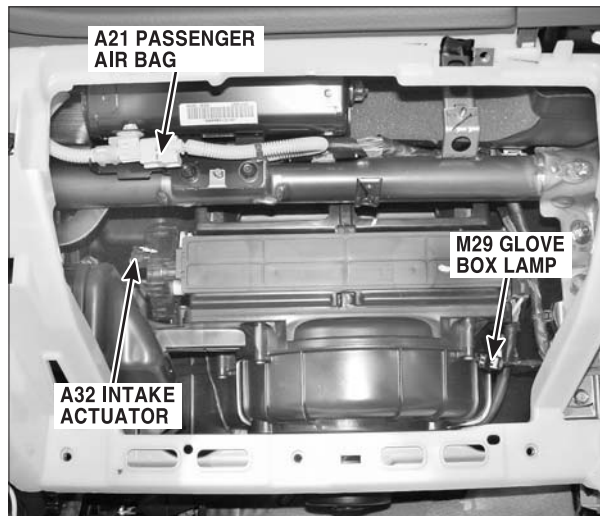
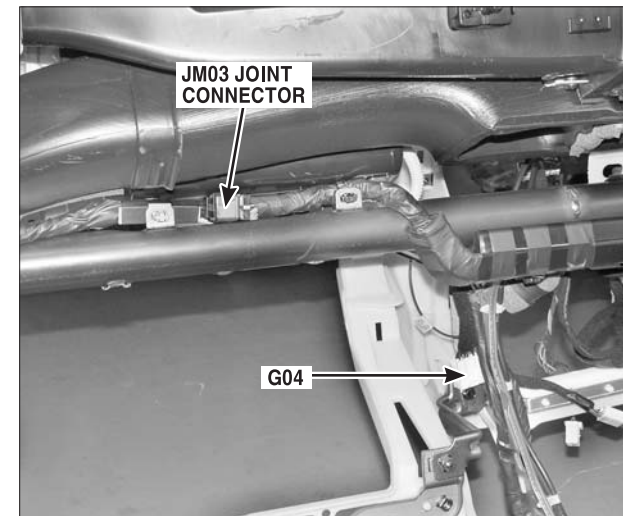

PHOTO.66





COMPONENT LOCATIONS

COMPONENT LOCATIONS(12)

CL-12

PHOTO.67

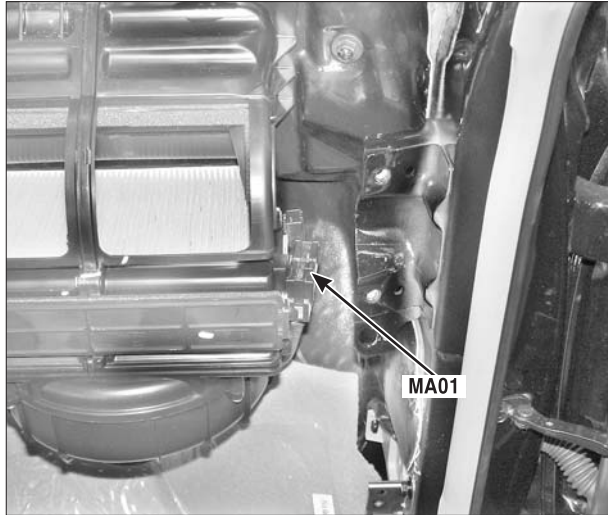

PHOTO.68

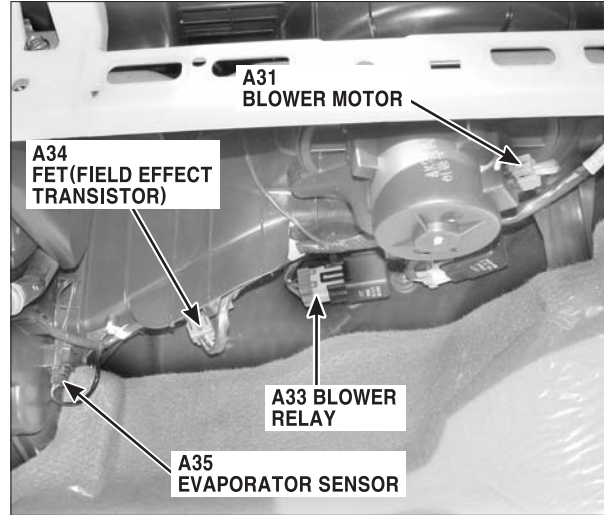

PHOTO.69

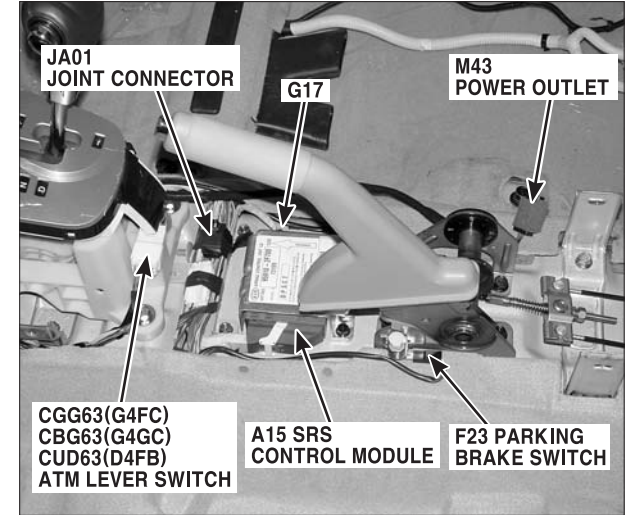

PHOTO.70

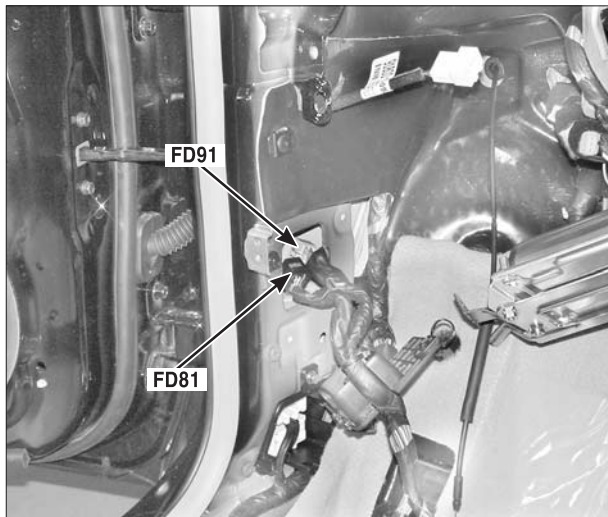

PHOTO.71

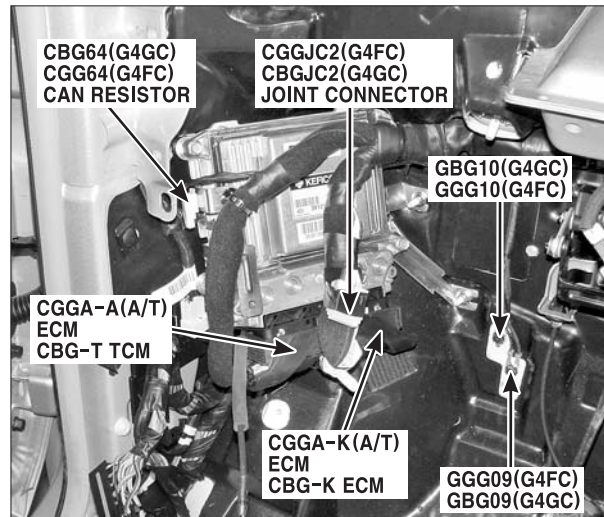
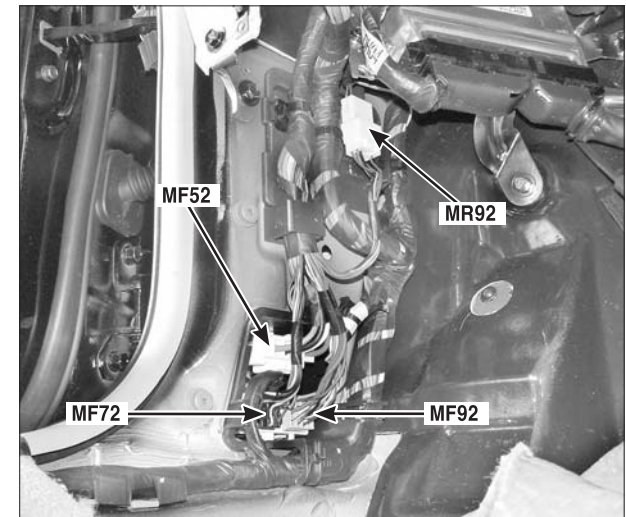

PHOTO.72



COMPONENT LOCATIONS

COMPONENT LOCATIONS(13)

CL-13

PHOTO.73

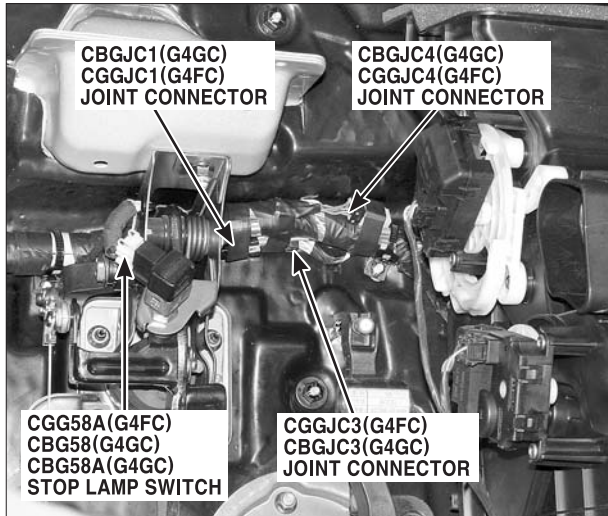

PHOTO.74

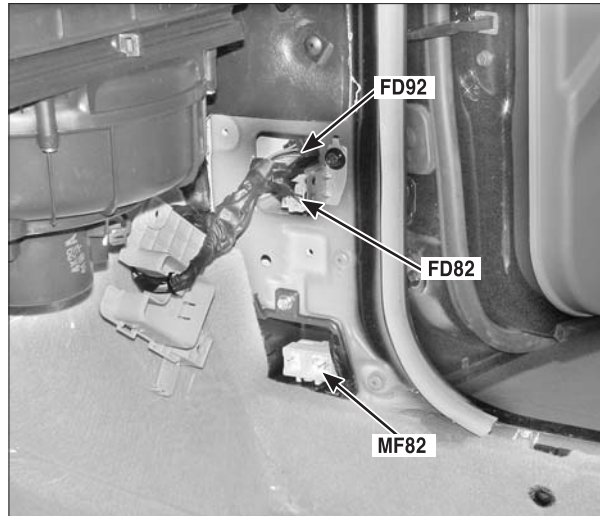

PHOTO.75

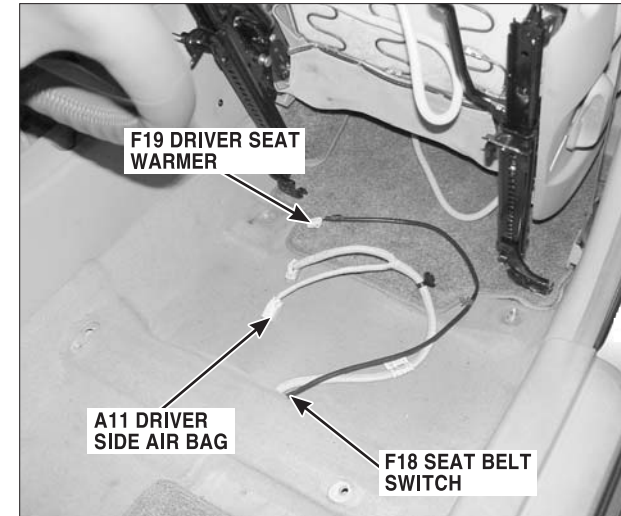

PHOTO.76

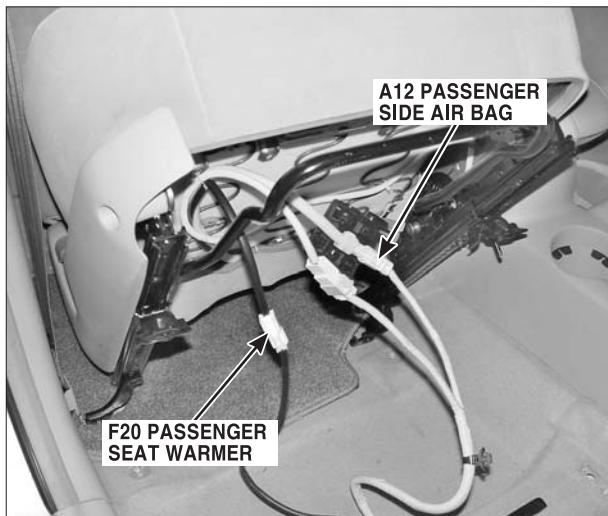

PHOTO.77

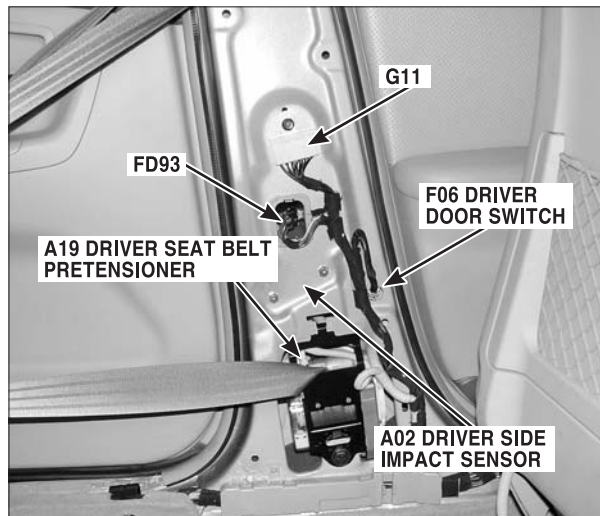
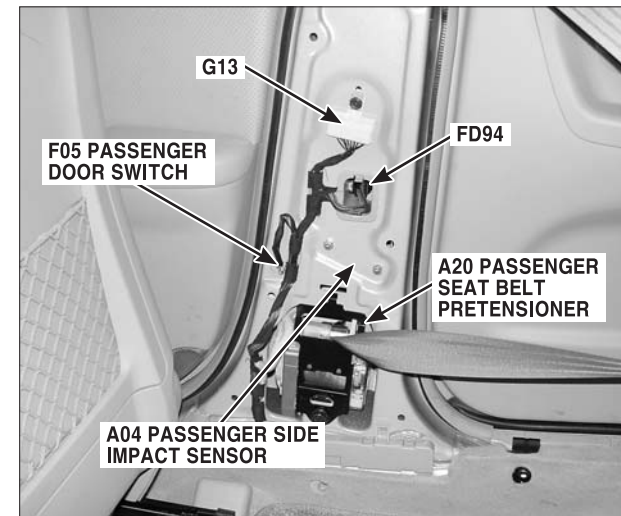

PHOTO.78





COMPONENT LOCATIONS

COMPONENT LOCATIONS(14)

CL-14

PHOTO.79

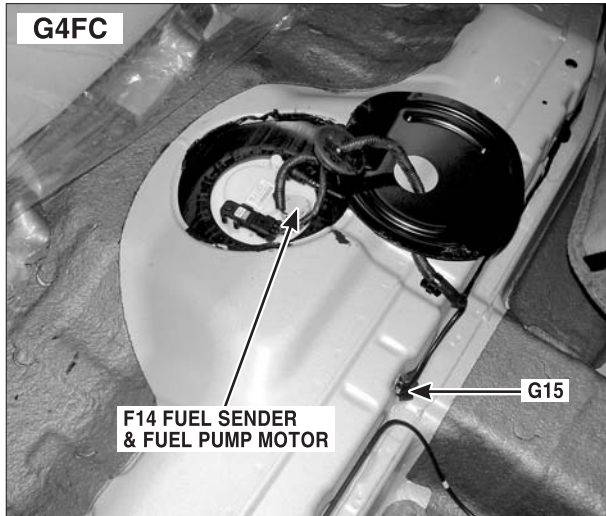

PHOTO.80

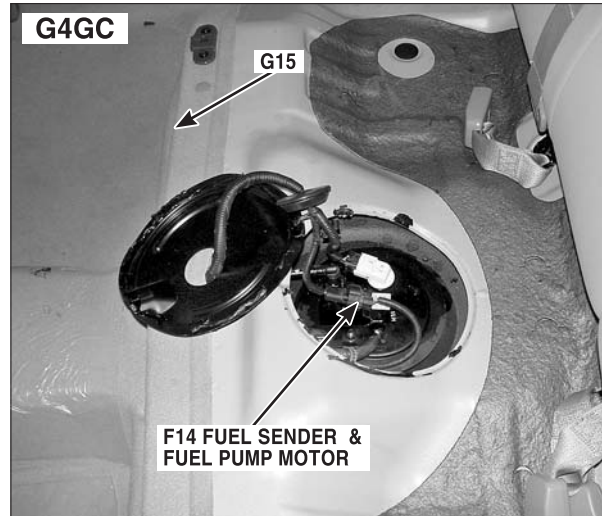

PHOTO.81

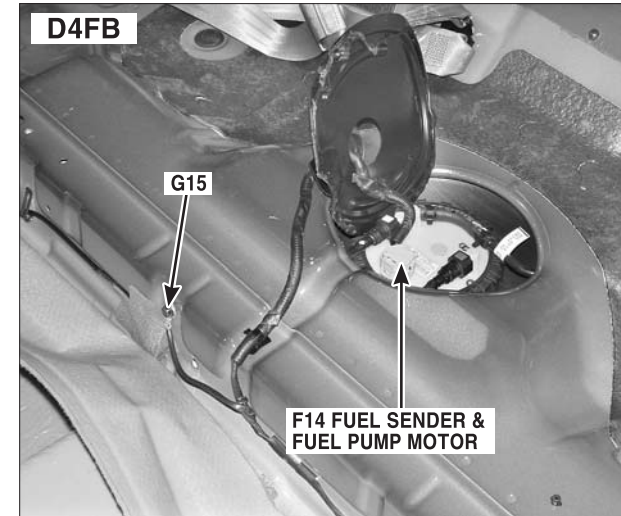

PHOTO.82

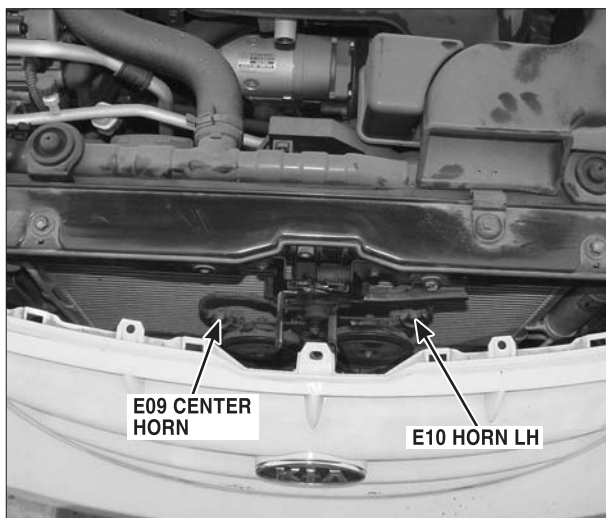

PHOTO.83

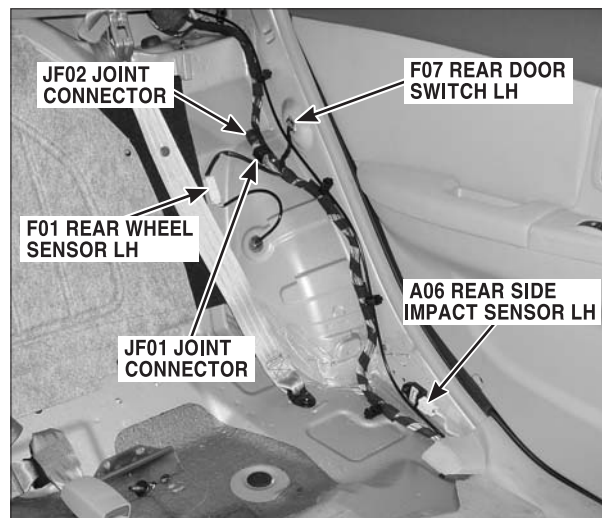
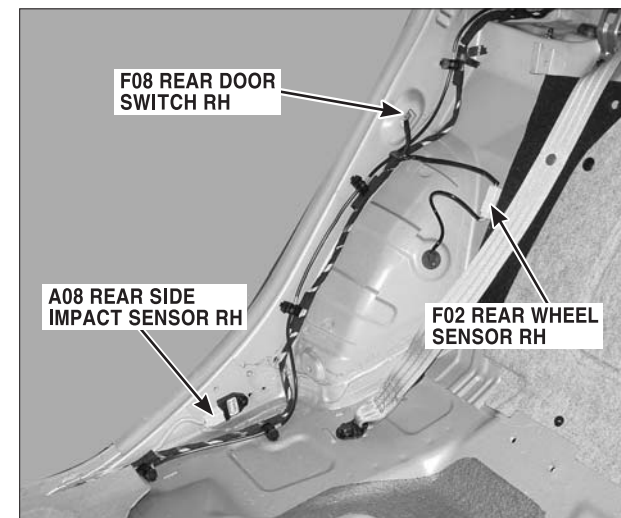

PHOTO.84



COMPONENT LOCATIONS

COMPONENT LOCATIONS(15)

CL-15

PHOTO.85

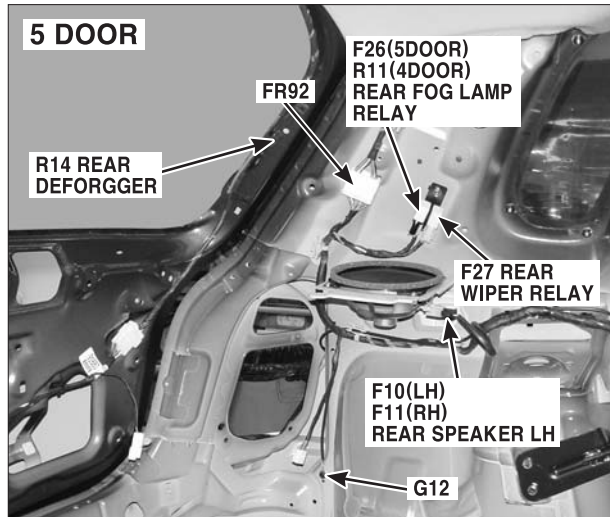

PHOTO.86

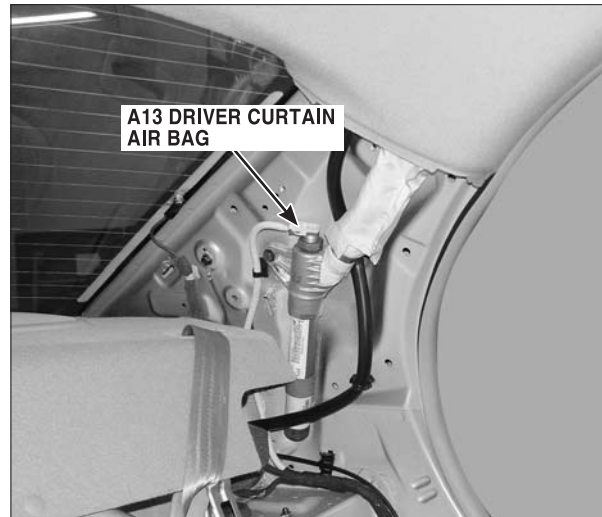

PHOTO.87



PHOTO.88

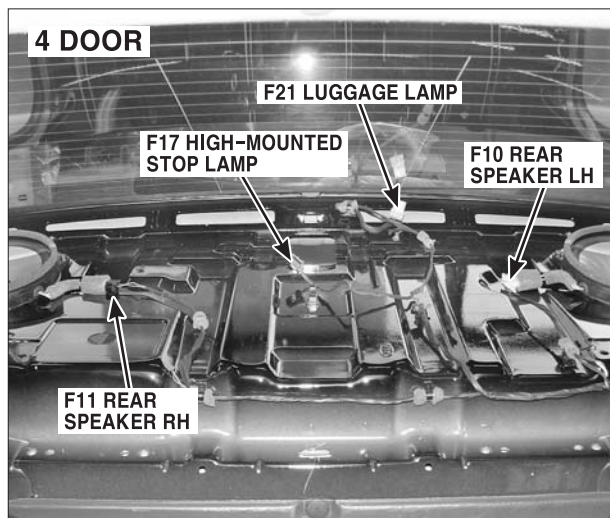

PHOTO.89

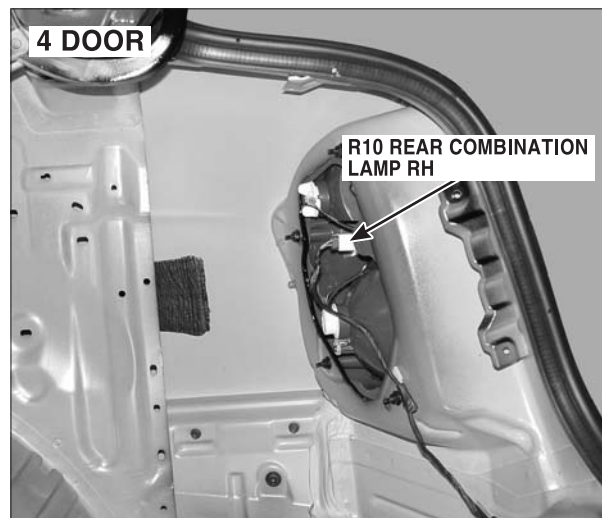
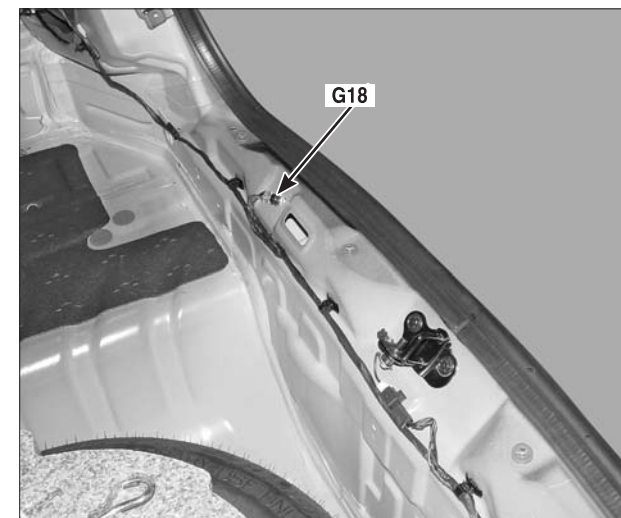

PHOTO.90





COMPONENT LOCATIONS

COMPONENT LOCATIONS(16)

CL-16

PHOTO.91

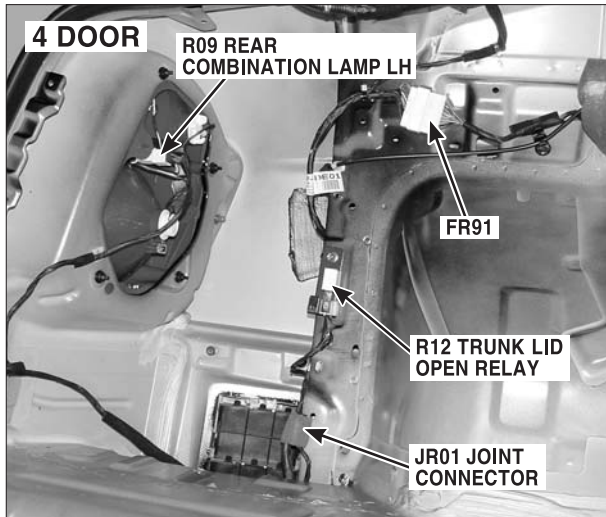

PHOTO.92



PHOTO.93

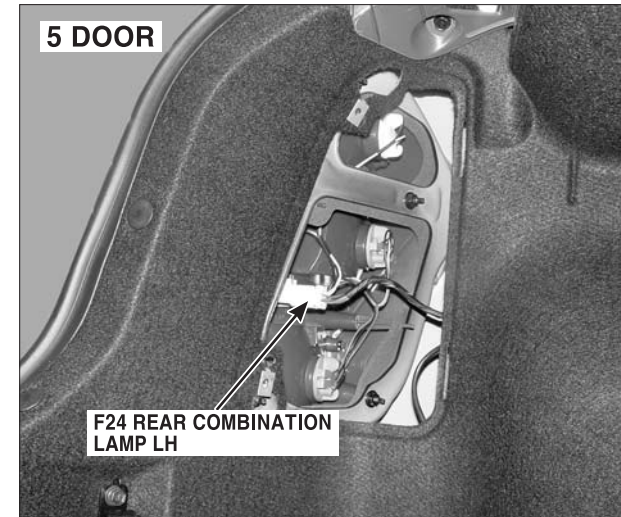

PHOTO.94

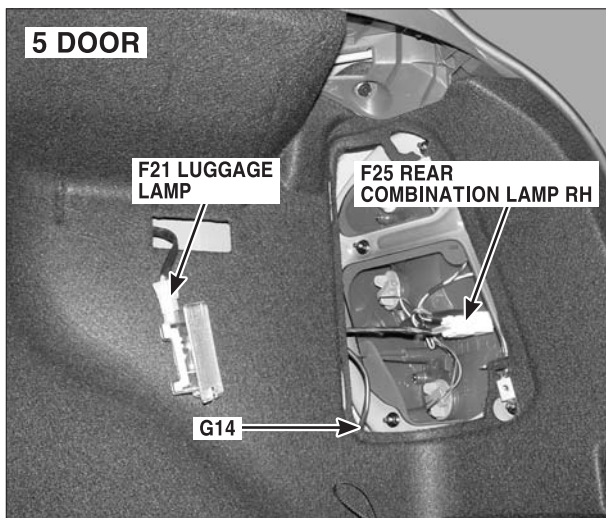

PHOTO.95

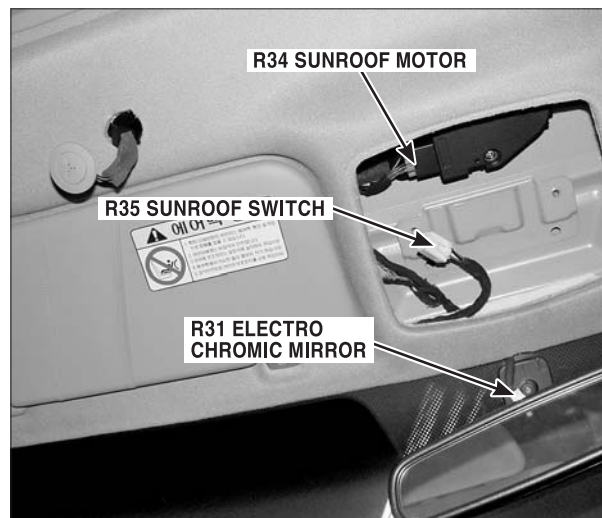

PHOTO.96



COMPONENT LOCATIONS

COMPONENT LOCATIONS(17)

CL-17

PHOTO.97



PHOTO.98

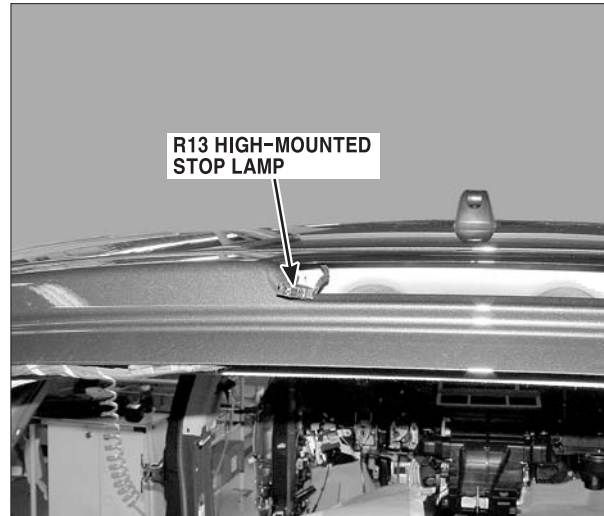

PHOTO.99

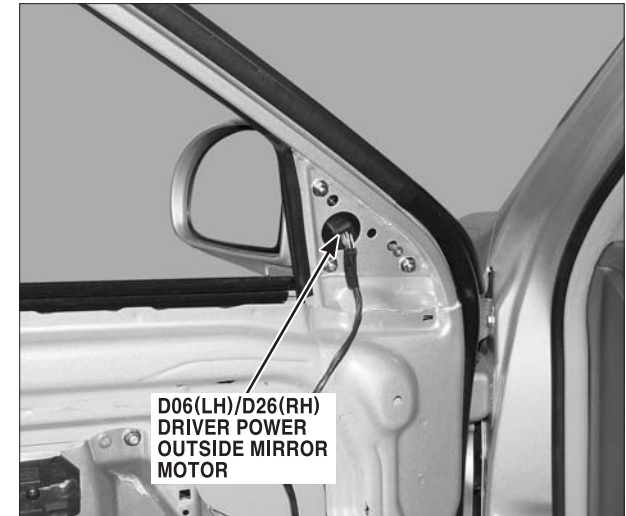

PHOTO.100

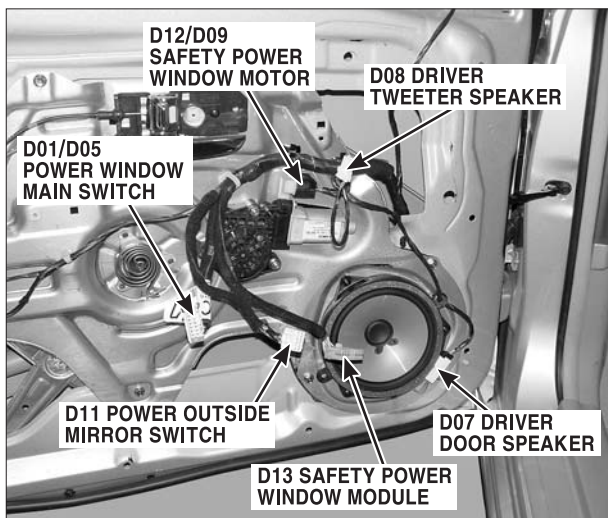

PHOTO.101

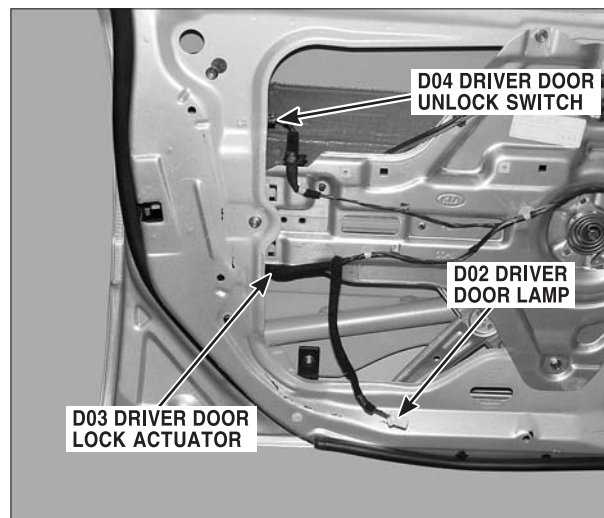
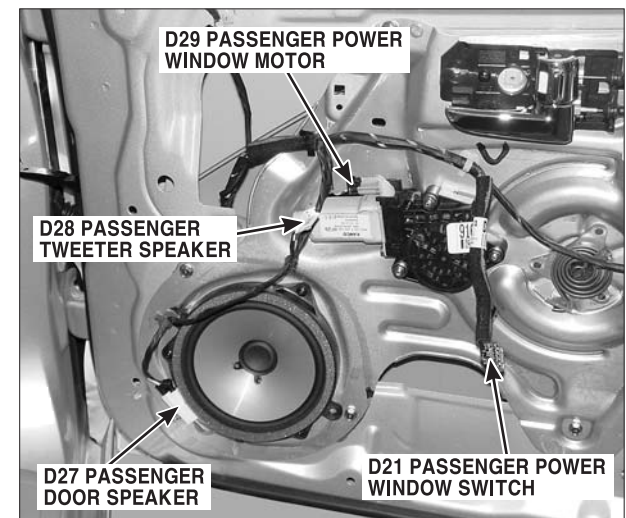

PHOTO.102





COMPONENT LOCATIONS

COMPONENT LOCATIONS(18)

CL-18

PHOTO.103

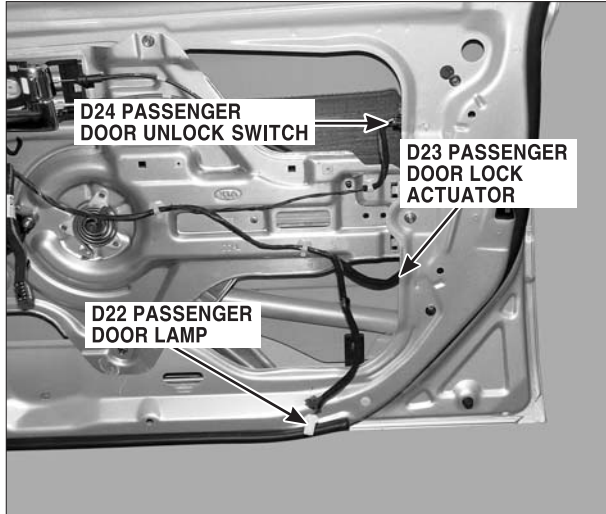

PHOTO.104

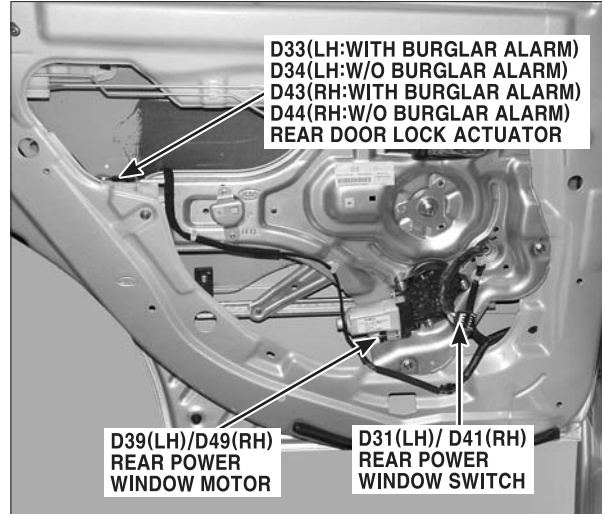

PHOTO.105

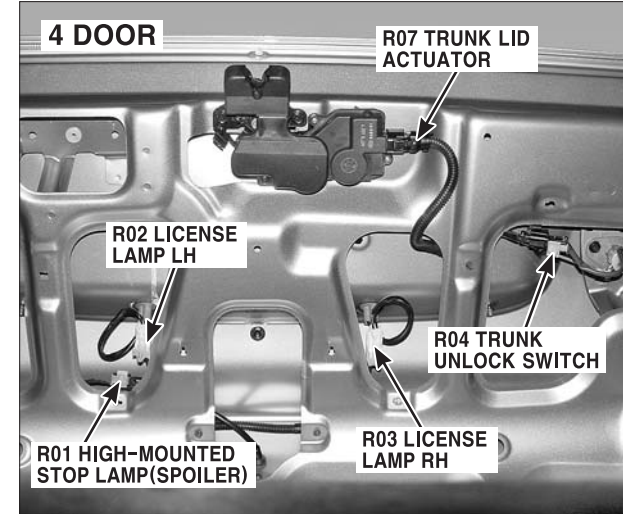

PHOTO.106

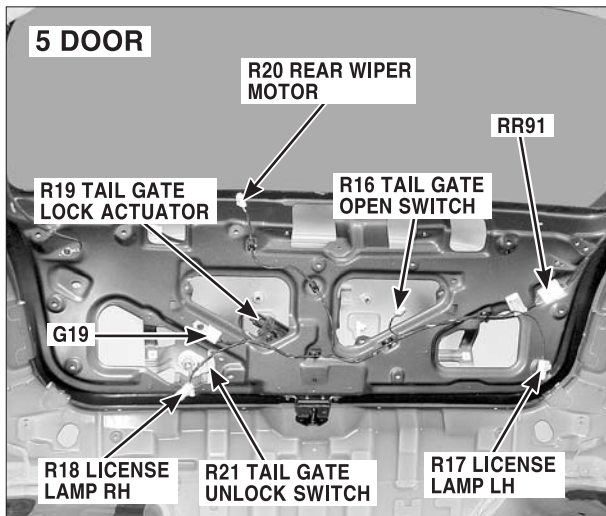

PHOTO.107

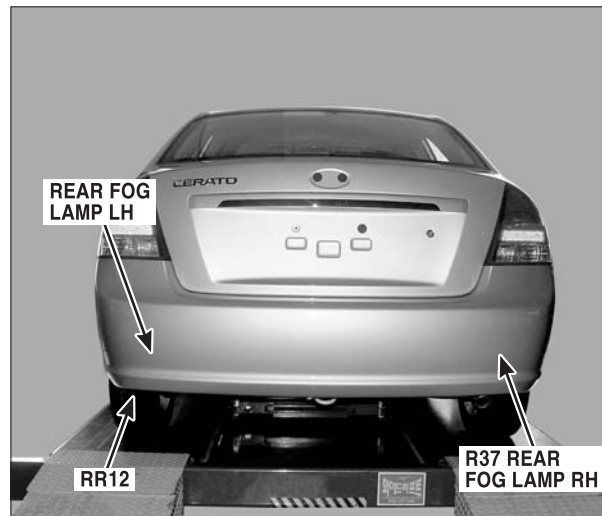
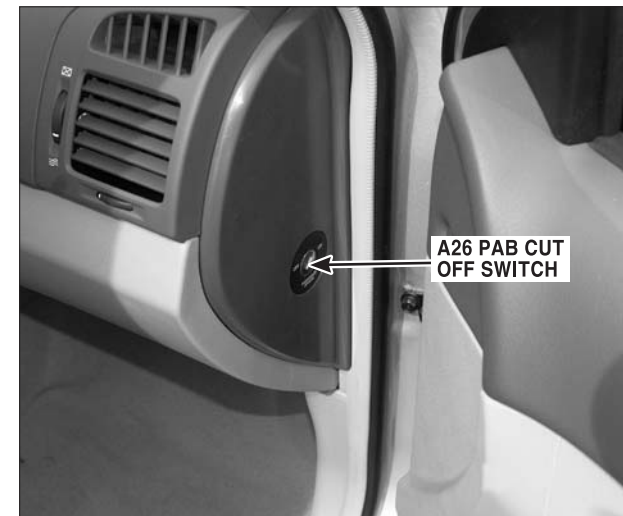
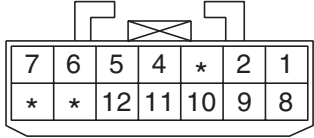
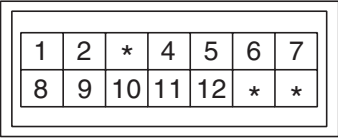

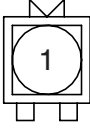
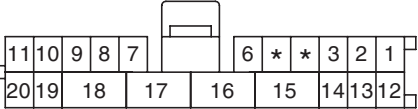
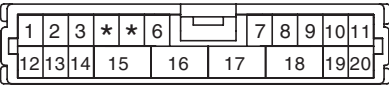

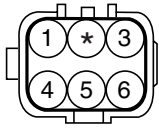
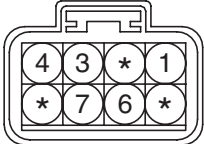
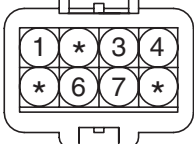
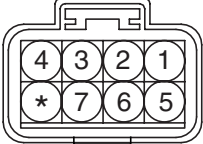
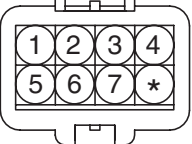
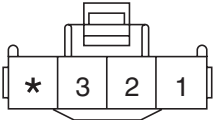
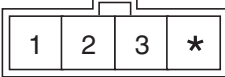

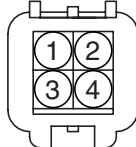
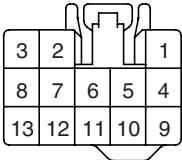
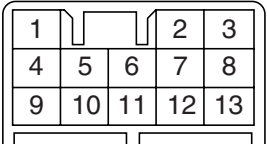
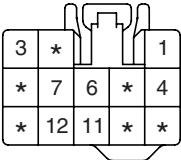
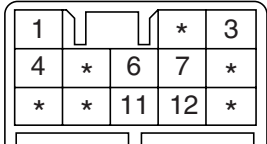

PHOTO.108



**HARNESS CONNECTORS**

EC814F14

HARNESS CONNECTORS (1)		CC-1
<p><b>AA91</b></p>  <p>AMP_MQS_14F</p>  <p>AMP_MQS_14M</p>	<p><b>CB11</b></p>  <p>KUM_NMWP_01F_B</p>  <p>KUM_NMWP_01M_B</p>	
<p><b>CF91</b></p>  <p>KET_2507_20F_W</p>  <p>KET_2507_20M_W</p>	<p><b>CGGIG</b></p>  <p>KUM_NMWP_06F_B</p>  <p>KUM_NMWP_06M_5</p>	
<p><b>CGGMT</b></p>  <p>KUM_NMWP_08F_B</p>  <p>KUM_NMWP_08M_B</p>	<p><b>CUDMT</b></p>  <p>KUM_NMWP_08F_B</p>  <p>KUM_NMWP_08M_B</p>	
<p><b>CUDPTC</b></p>  <p>KET_312II_04F</p>  <p>KET_MG_641928</p>	<p><b>EE11</b></p>  <p>KUM_NMWP_04F_B</p>  <p>KUM_NMWP_04M_B</p>	
<p><b>FD81</b></p>  <p>KET_090III_13F</p>  <p>KET_DOOR_13M_W_0509</p>	<p><b>FD82</b></p>  <p>KET_090III_13F</p>  <p>KET_DOOR_13M_W_0509</p>	



HARNESS CONNECTORS

HARNESS CONNECTORS (2)

CC-2

FD91

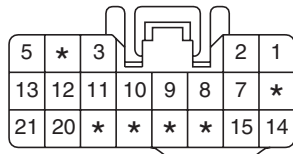

KET\_050\_21F\_B

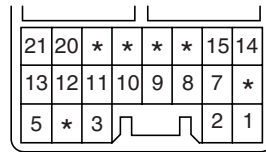

KET\_DOOR\_21M\_W\_0509

FD92

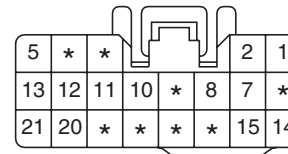

KET\_050\_21F\_B

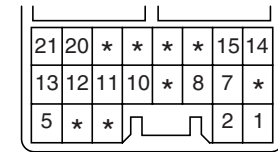

KET\_DOOR\_21M\_W\_0509

FD93

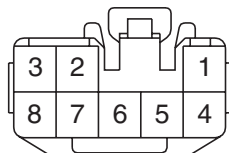

KET\_090II\_08F

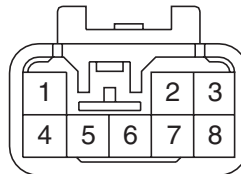

KET\_090II\_08M

FD94

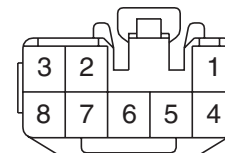

KET\_090II\_08F

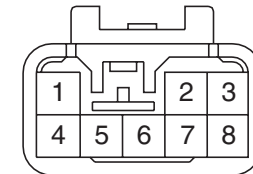

KET\_090II\_08M

FR91

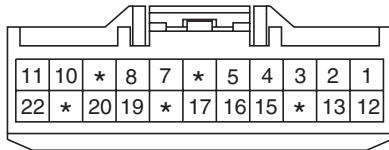

AMP\_090III\_22F\_W

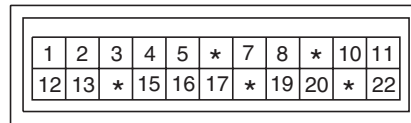

AMP\_090III\_22M\_W

FR92

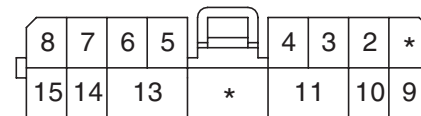

AMP\_070250\_15F

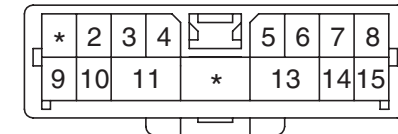

AMP\_070250\_15M

MA01

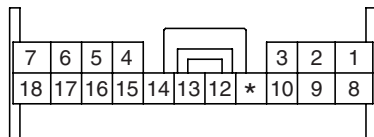

KUM\_2505\_18F\_B

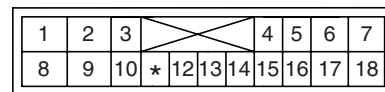

KUM\_HY031\_18027

MA91

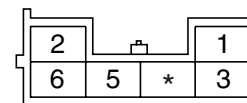

KET\_SDL\_06F

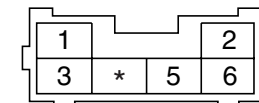

KET\_SDL\_06M

MC71

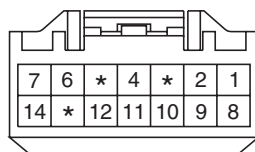

AMP\_090III\_14F\_W

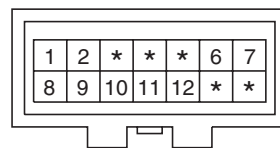

AMP\_090III\_14M\_W

MC81

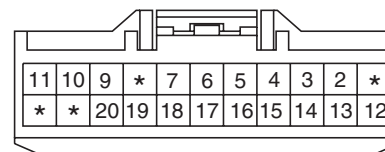

AMP\_090III\_22F\_W

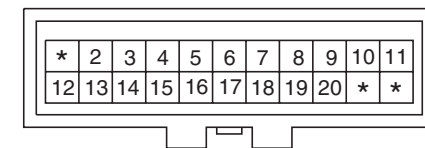

AMP\_090III\_22M\_W

HARNESS CONNECTORS

HARNESS CONNECTORS (3)

CC-3

MC91

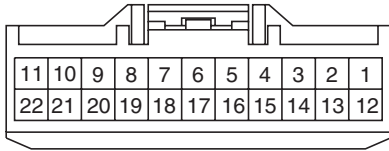

AMP\_090III\_22F\_L

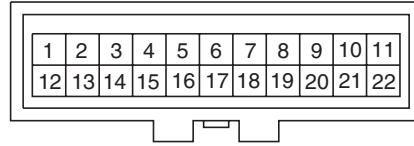

AMP\_090III\_22M\_L

MF52

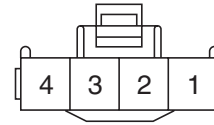

KET\_312II\_04F\_W

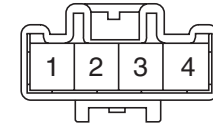

KET\_312II\_04M\_W

MF72

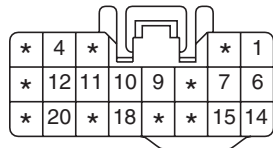

KET\_21F\_W

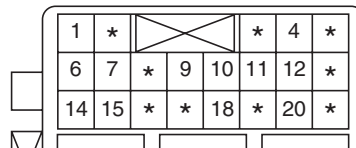

KET\_180905\_21M\_W

MF82

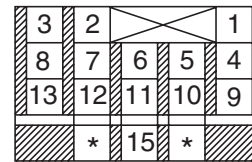

KET\_090II+187II

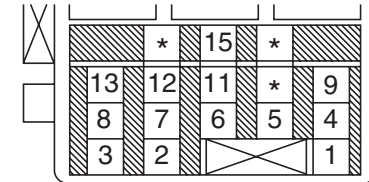

KET\_180905\_16M\_W

MF92

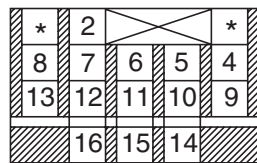

KET\_090II+187II

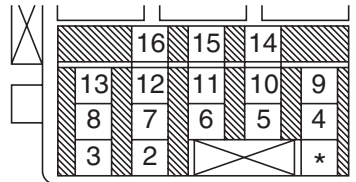

KET\_180905\_16M\_W

MM91

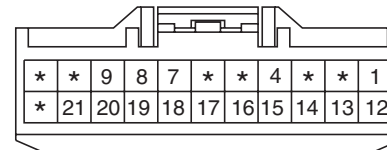

AMP\_090III\_22F\_N

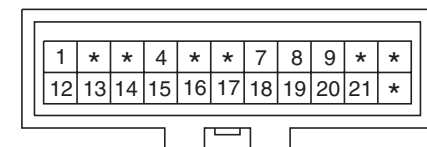

AMP\_090III\_22M\_W

MR92

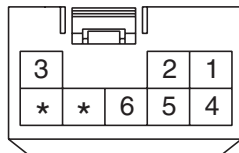

AMP\_090III\_08F\_W

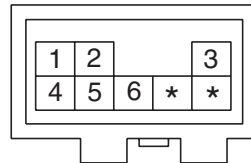

AMP\_090III\_08M\_W

RR12



KET\_090IWP\_3F\_B



CR03M024

RR91

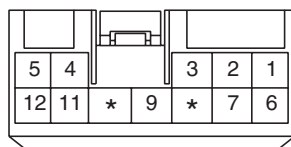

AMP\_090III\_12F

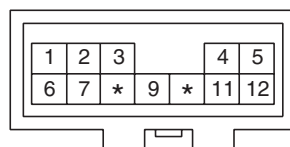

AMP\_090III\_14M

BLANK

ENGINE COMPARTMENT JUNCTION BOX E0EDD0CB

ENGINE COMPARTMENT JUNCTION BOX (1)

CC-4

E/R-CGG

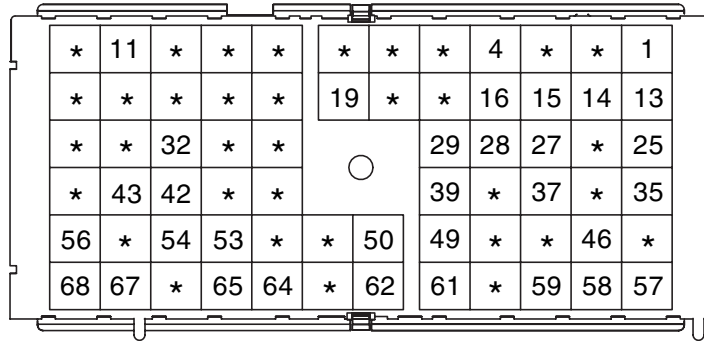

PKD\_280\_68F\_N\_104

E/R-CBG

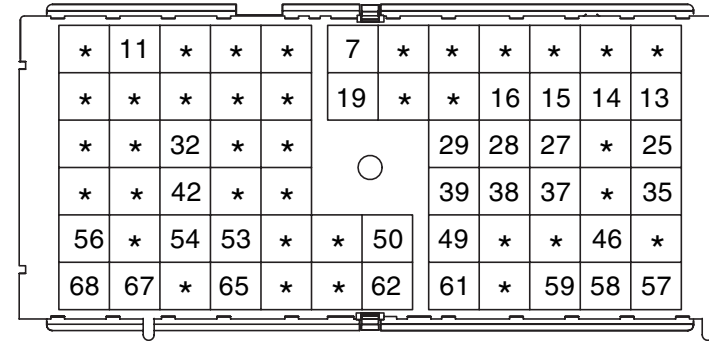

PKD\_280\_68F\_N\_104

E/R-CUD

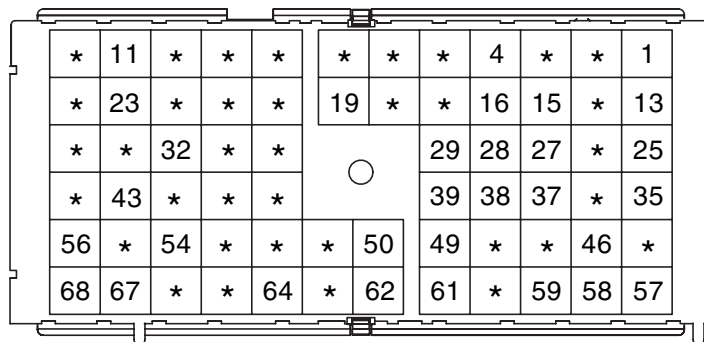

PKD\_280\_68F\_N\_104

E/R-FRT

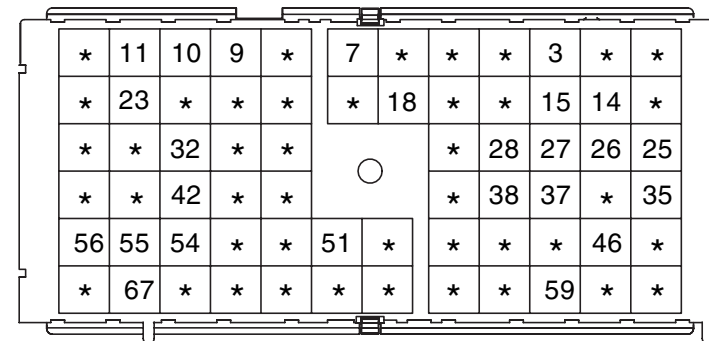

PKD\_280\_68F\_B\_102

ENGINE COMPARTMENT JUNCTION BOX

ENGINE COMPARTMENT JUNCTION BOX (2)

CC-5

E/R-FLR1

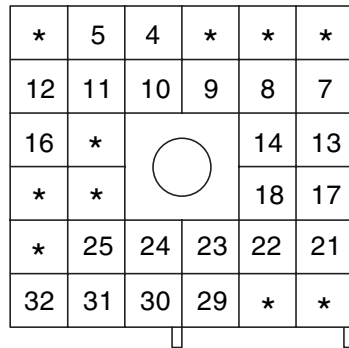

PKD\_280\_32W\_N\_101

E/R-FLR2

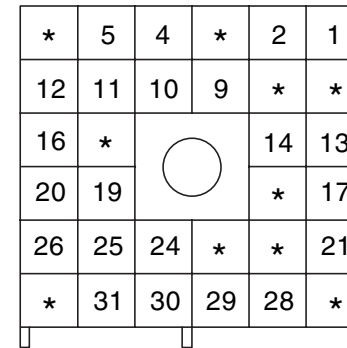

PKD\_280\_32W\_GR\_102

E/R-FLR3

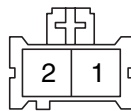

PKD\_280\_02F\_GR\_104

E/R-FLR4

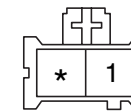

PKD\_280\_02F\_W\_102

PASSENGER COMPARTMENT JUNCTION BOX EAD2F04A

PASSENGER COMPARTMENT JUNCTION BOX (1)

CC-6

I/P-F

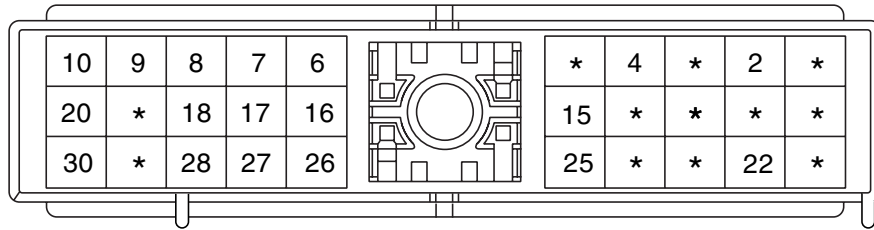

PKD\_280\_30F

I/P-M1

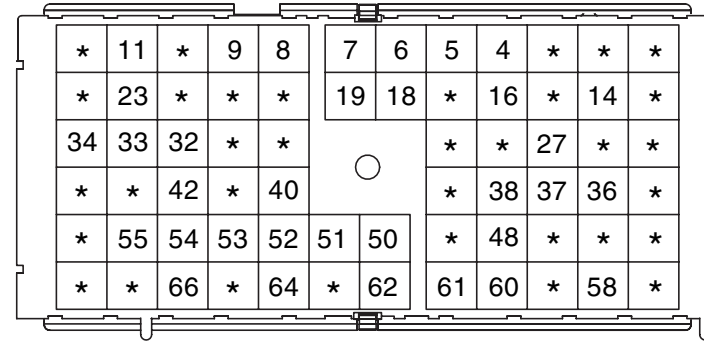

PKD\_280\_68F\_B\_102

I/P-M2

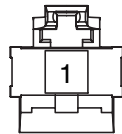

PKD\_800\_01F\_B\_BECEB

BLANK

JOINT CONNECTORS EBE6DCBF

CC-7

JOINT CONNECTORS (1)

CGGJC1

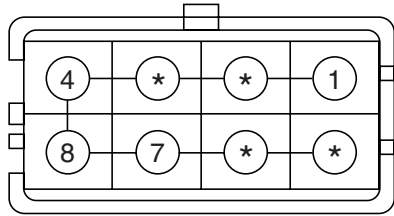

KET\_070\_8F\_B

CGGJC2

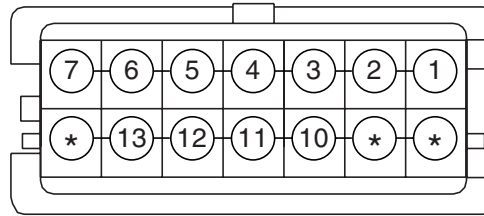

KET\_070\_14F\_Gr

CGGJC3

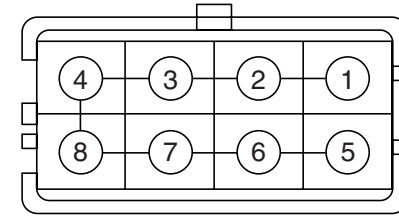

KET\_070\_8F\_B

CGGJC4

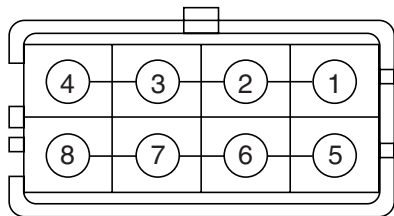

KET\_070\_8F\_B

CBGJC1

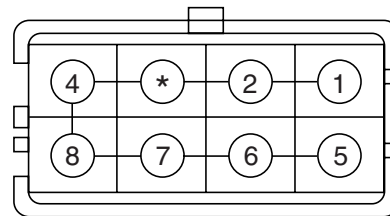

KET\_070\_8F\_B

CBGJC2

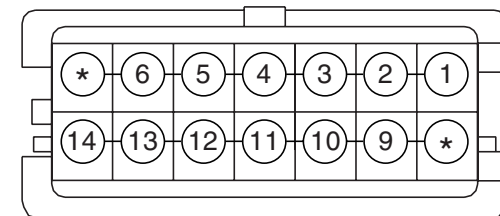

KET\_070\_14F\_W

CBGJC3

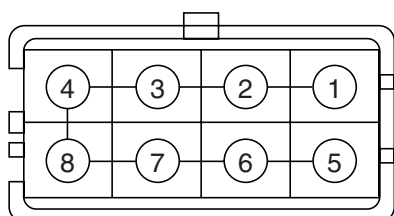

KET\_070\_8F\_B

CBGJC4

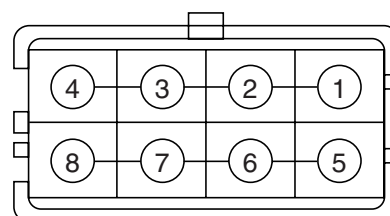

KET\_070\_8F\_B

CUDJC1

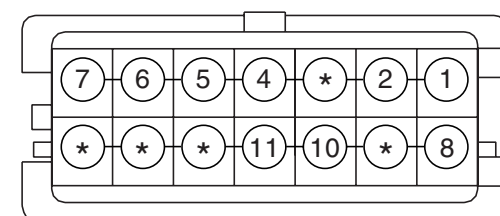

KET\_070\_14F\_W

CUDJC2

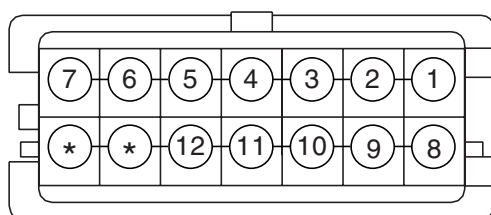

KET\_070\_14F\_Gr

CUDJC3

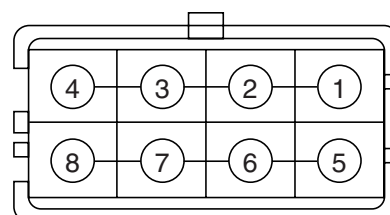

KET\_070\_8F\_B

JA01

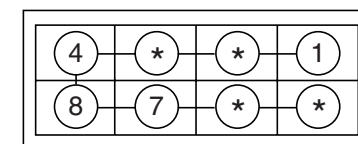

KET

JOINT CONNECTORS

JOINT CONNECTORS (2)

CC-8

JF01

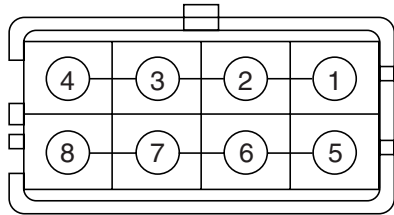

KET\_070\_08F\_JCH\_B

JF02

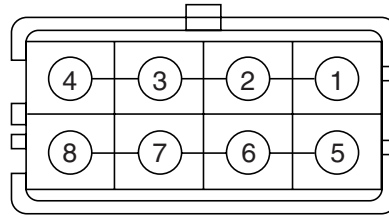

KET\_070\_08F\_JCH\_B

JM01

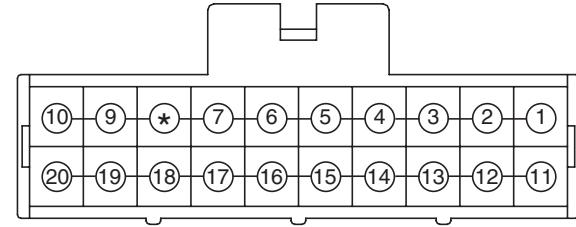

KET\_090II\_20F\_B\_JCH

JM02

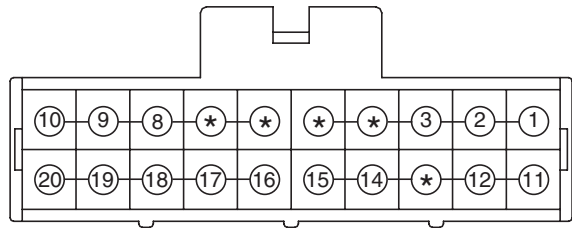

KET\_090II\_20F\_B\_JCH

JM03

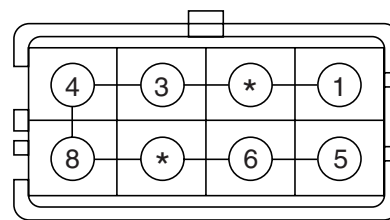

KET\_070\_08F\_B\_JCH

JR01

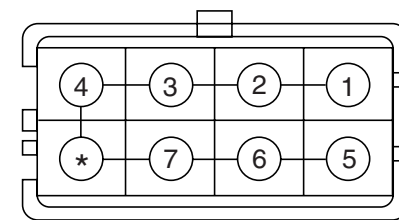

KET\_070\_08F\_JCH\_B

MAIN HARNESS ECA8146A

MAIN HARNESS (1)

HL-1

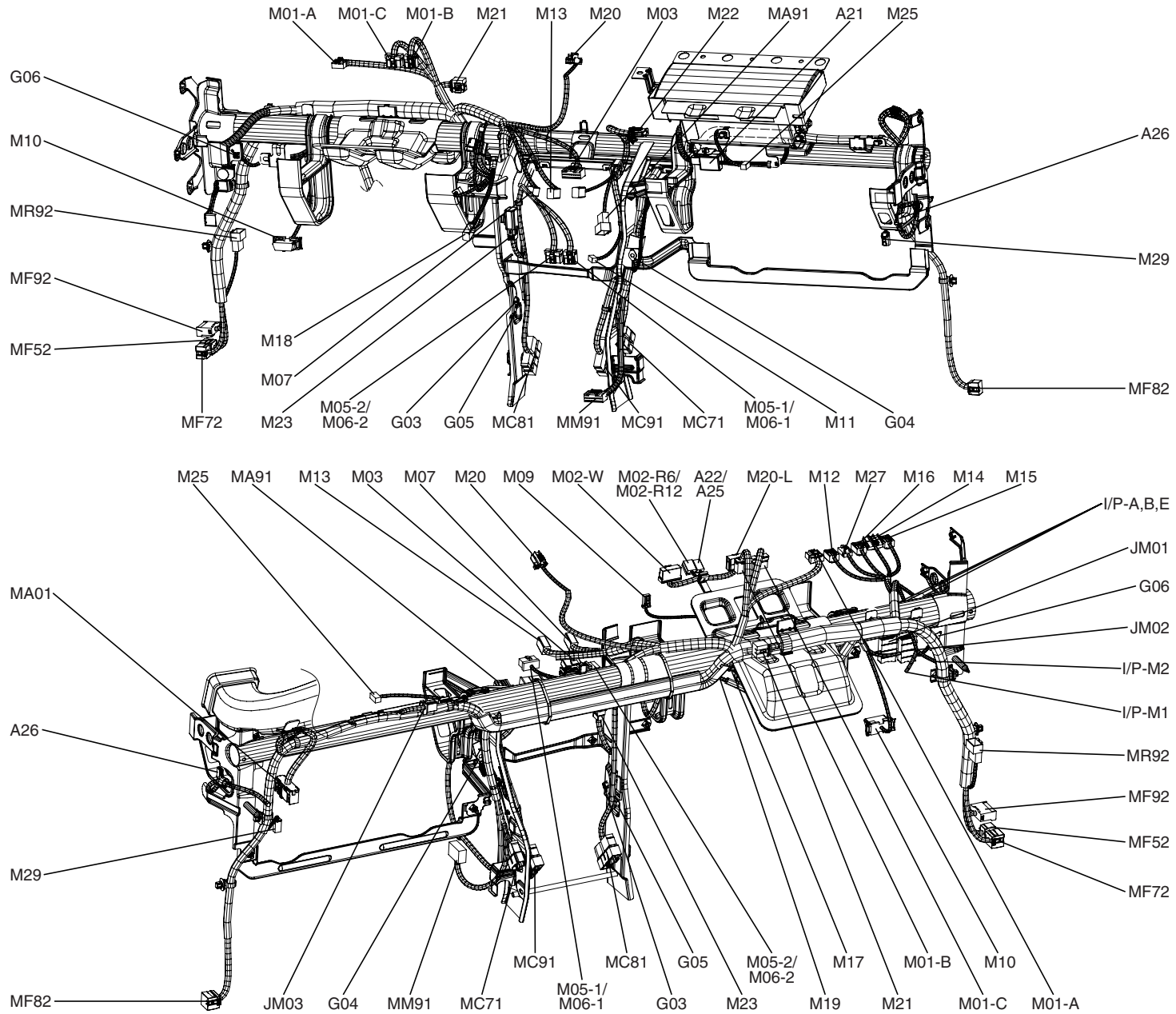



**MAIN HARNESS****MAIN HARNESS (2)****HL-2****MAIN HARNESS**

M01-A	Instrument cluster	I/P-M1	Connection with I/P JUNCTION BOX harness
M01-B	Instrument cluster	I/P-M2	Connection with I/P JUNCTION BOX harness
M01-C	Instrument cluster	MA01	Connection with A/C harness
M02-L	Multifunction switch	MA91	Connection with AIR BAG EXT. harness
M02-R6	Multifunction switch	MC71	Connection with CONTROL harness
M02-R12	Multifunction switch	MC81	Connection with CONTROL harness
M02-W	Multifunction switch	MC91	Connection with CONTROL harness
M03	Audio	MF52	Connection with FLOOR harness
M05-1	A/C control module(Auto)	MF72	Connection with FLOOR harness
M05-2	A/C control module(Auto)	MF82	Connection with FLOOR harness
M06-1	A/C control module(Manual)	MF92	Connection with FLOOR harness
M06-2	A/C control module(Manual)	MM91	Connection with CONSOLE EXT. harness
M07	Trip switch	MR92	Connection with ROOF harness
M09	Immobilizer control module	G03	Ground
M10	Data link connector	G04	Ground
M11	Cigarette lighter	G05	Ground
M12	Trunk lid open switch	G06	Ground
M13	Hazard switch		
M14	Head lamp leveling switch		
M15	Rear fog lamp switch		
M16	TCS switch		
M17	Ignition switch		
M18	Active incar & Humidity sensor		
M19	Door warning switch		
M20	Digital clock		
M21	Auto light & Photo sensor		
M23	Auto light control module		
M25	Keyless entry receiver		
M27	Rheostat		
M29	Glove box lamp		
JM01	Joint connector		
JM02	Joint connector		
JM03	Joint connector		
I/P-A	Connection with BCM harness		
I/P-B	Connection with BCM harness		
I/P-E	Connection with BCM harness		

**CONSOLE EXT. HARNESS**

M41	Front seat warmer switch LH
M42	Front seat warmer switch RH
M43	Power outlet
M45	Audio jack
MM91	Connection with MAIN harness

**REMOCON SWITCH HARNESS**

M46	Multifunction switch(With cruise)
M47	Multifunction switch(W/O cruise)

**AIR BAG EXT. HARNESS**

A21	Passenger air bag
A22	Driver air bag(W/O cruise)
A25	Driver air bag(With cruise)
A26	PAB cut off switch
AA91	Connection with AIR BAG harness
MA91	Connection with MAIN harness

FRONT HARNESS E40CA2AF

FRONT HARNESS (1)

HL-3

LH

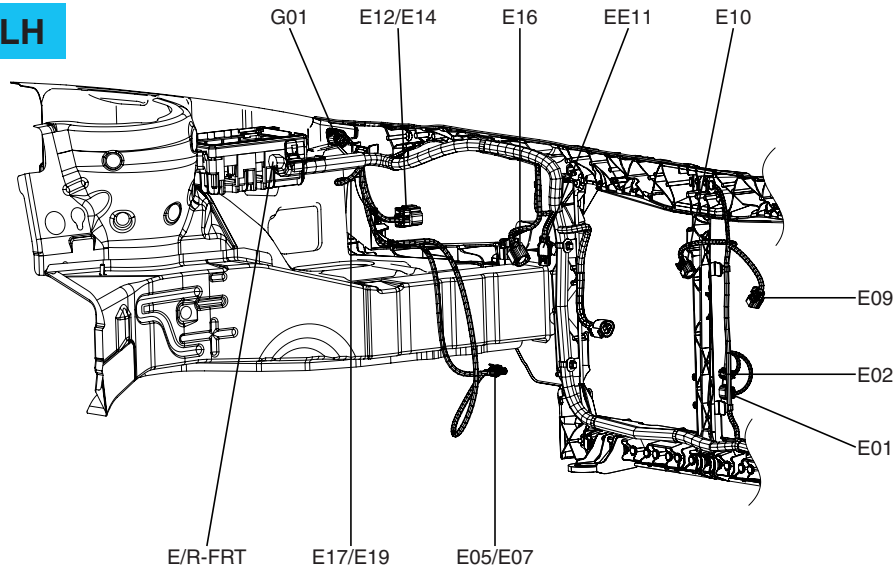

RH

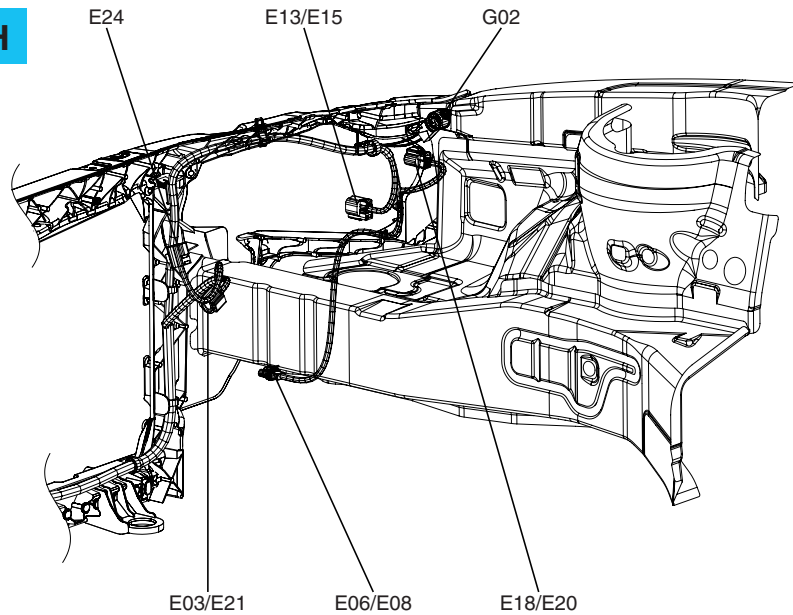

FRONT HARNESS

- E01 AQS sensor
- E02 Ambient sensor
- E03 Condenser fan motor(G4GC)
- E05 Front fog lamp LH(MFR)
- E06 Front fog lamp RH(MFR)
- E07 Front fog lamp LH(PRO)
- E08 Front fog lamp RH(PRO)
- E09 Center horn
- E10 Horn LH
- E12 Head lamp LH(W/O HLLD)
- E13 Head lamp RH(W/O HLLD)
- E14 Head lamp LH(With HLLD)
- E15 Head lamp RH(With HLLD)
- E16 Radiator fan motor(G4GC)
- E17 Front position lamp LH
- E18 Front position lamp RH
- E19 Front turn signal lamp LH
- E20 Front turn signal lamp RH
- E21 Cooling fan motor(G4FC/D4FB)
- E24 A/C pressure transducer(G4FC/D4FB)
- EE11 Connection with BATTERY harness
- E/R-FRT Connection with E/R JUNCTION BOX harness
- G01 Ground
- G02 Ground

**BATTERY HARNESS** E92EA7D4

**BATTERY HARNESS (1)**

**HL-4**

**G4FC**

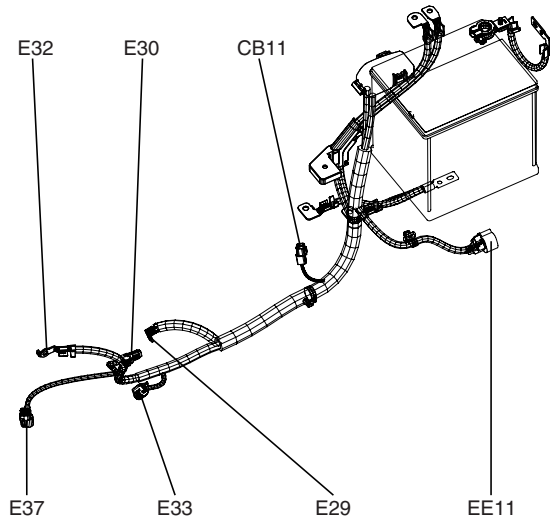

**G4GC**

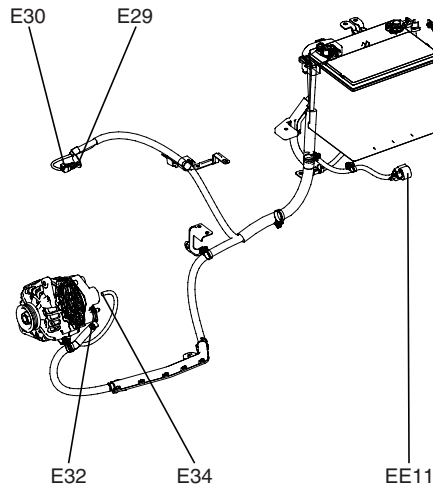

**D4FB**

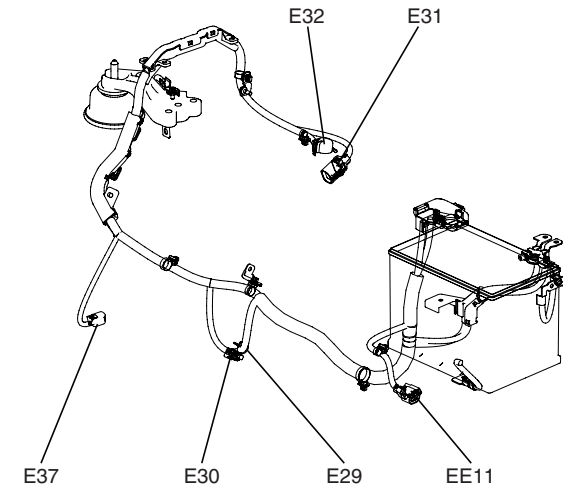

**BATTERY HARNESS(G4FC)**

- E29 Start motor
- E30 Start solenoid
- E32 Generator
- E33 Oil pressure switch
- E37 A/C compressor
- CB11 Connection with CONTROL harness
- EE11 Connection with FRONT harness

**BATTERY HARNESS(G4GC)**

- E29 Start motor
- E30 Start solenoid
- E32 Generator
- E34 Generator
- EE11 Connection with FRONT harness

**BATTERY HARNESS(D4FB)**

- E29 Start motor
- E30 Start solenoid
- E31 Generator
- E32 Generator
- E37 A/C compressor
- EE11 Connection with FRONT harness

FLOOR HARNESS (1)

HL-5

5DR LH

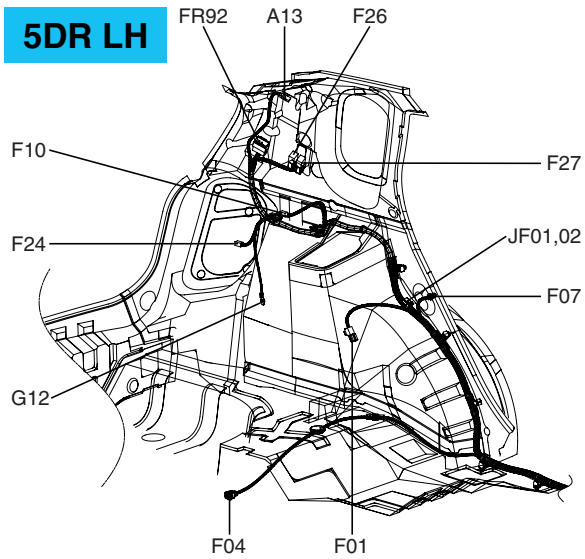

5DR RH

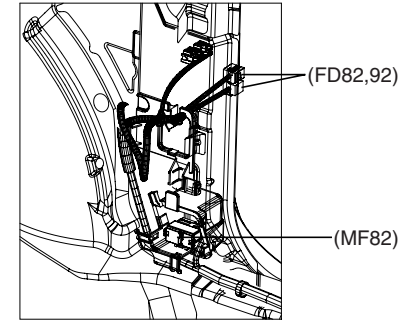
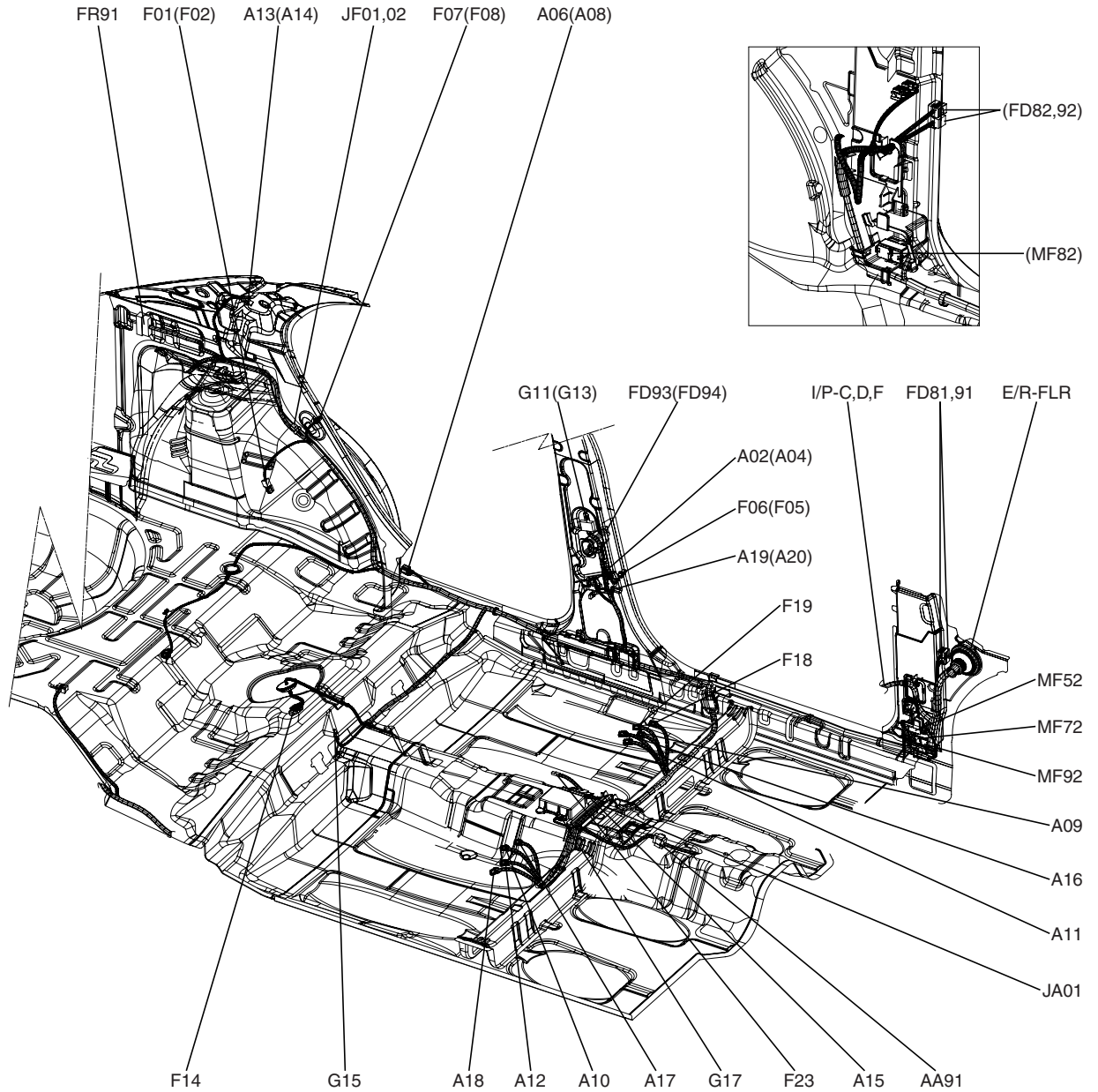
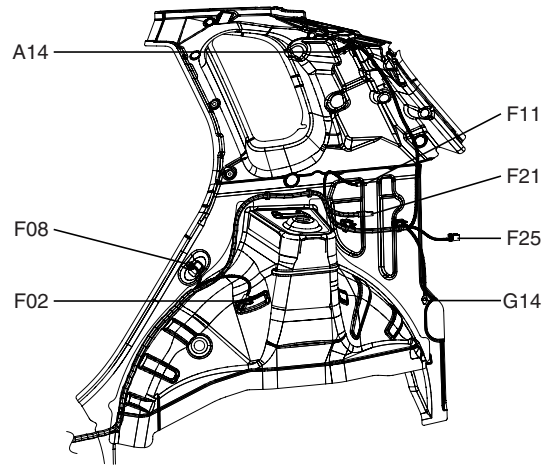

( ) : RIGHT



CONTROL HARNESS E3FB1954

CONTROL HARNESS (G4FC) (1)

HL-7

LH

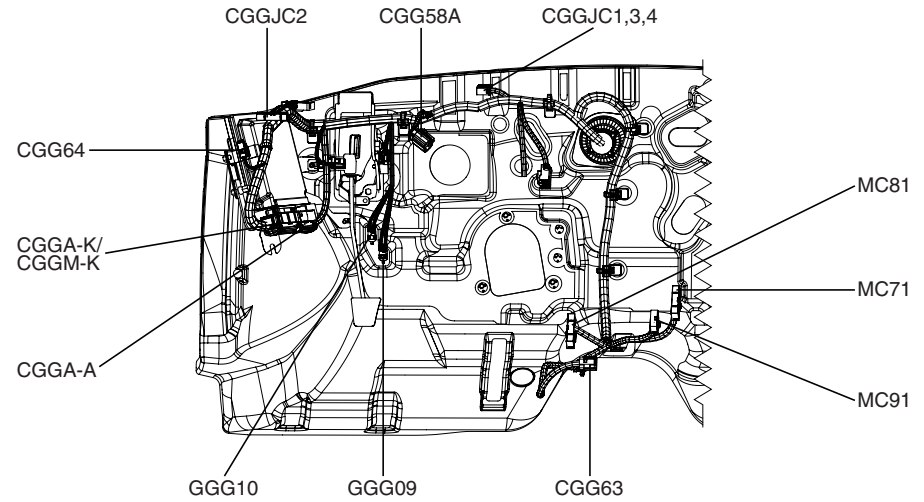
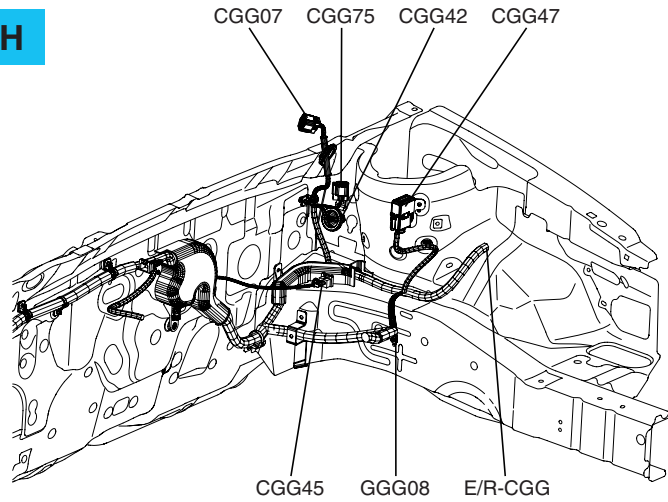

RH

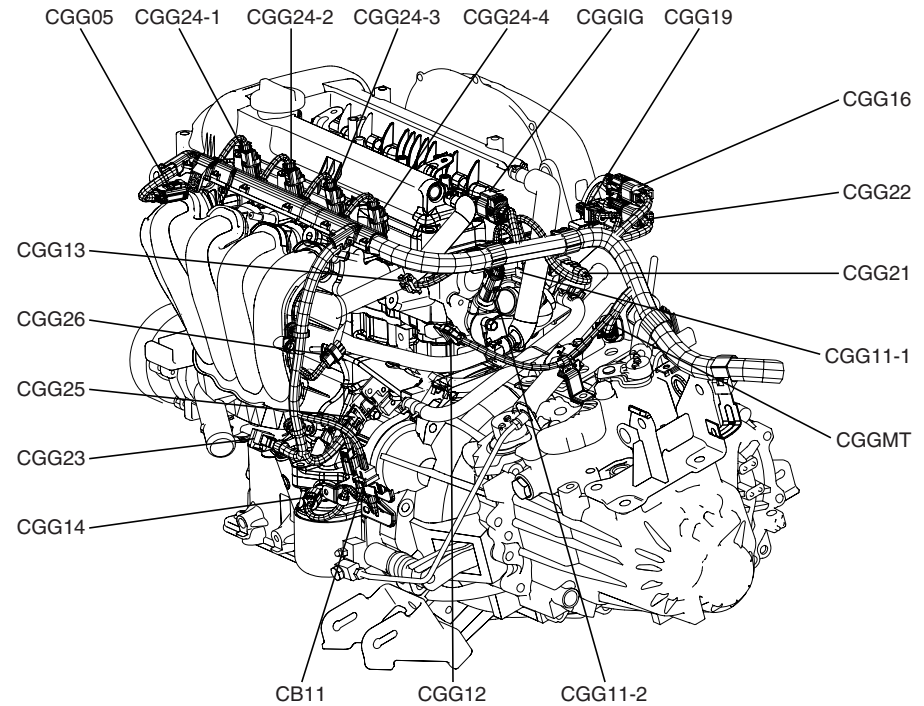
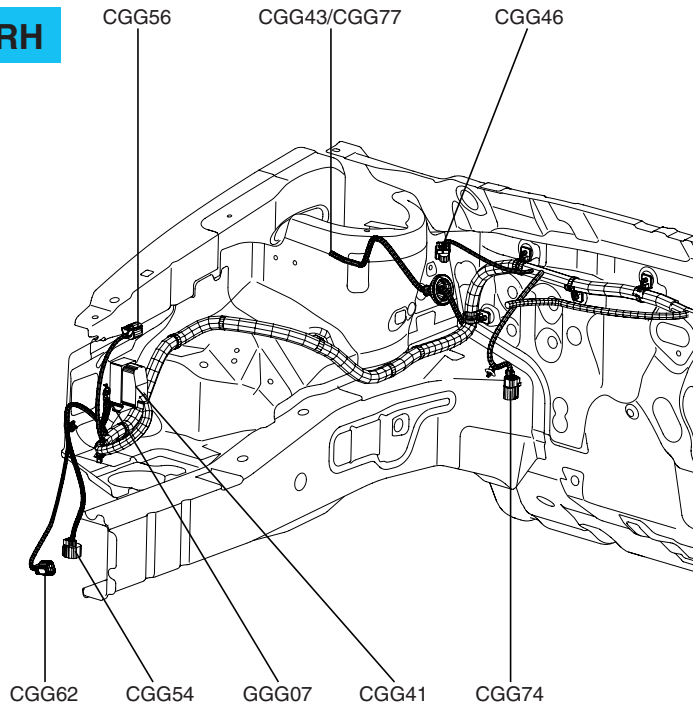



**CONTROL HARNESS****CONTROL HARNESS (G4FC) (2)****HL-8****CONTROL HARNESS**

CGGA-A	ECM(A/T)
CGGA-K	ECM(A/T)
CGGM-K	ECM(M/T)
CGG01	Transaxle range switch
CGG02-A	Pulse generator 'A'
CGG02-B	Pulse generator 'B'
CGG04	ATM solenoid valve
CGG05	Oil control valve
CGG06	Generator
CGG07	Front wiper motor
CGG11-1	Engine coolant temperature sensor
CGG11-2	Engine coolant temperature sender
CGG12	Throttle position sensor
CGG13	Camshaft position sensor
CGG14	Crankshaft position sensor
CGG16	Oxygen sensor(Up)
CGG19	Condenser
CGG21	Purge control solenoid valve
CGG22	Oxygen sensor(Down)(Euro III/IV)
CGG23	Knock sensor
CGG24-1	Injector #1
CGG24-2	Injector #2
CGG24-3	Injector #3
CGG24-4	Injector #4
CGG25	MAP sensor
CGG26	Idle speed actuator
CGG41	ABS control module
CGG42	Front wheel sensor LH
CGG43	Front wheel sensor RH
CGG45	Brake fluid Level sensor
CGG46	Burglar alarm horn
CGG47	Multipurpose check connector
CGG54	Front washer motor
CGG56	Hood switch
CGG58A	Stop lamp switch
CGG59	Side repeater lamp RH
CGG62	Washer level switch

CGG63	ATM lever switch
CGG64	CAN resistor
CGG74	Power steering switch
CGG75	Fuel cut sensor
CGG77	Wheel sensor(With EURO III/IV & W/O ABS/TCS)
CGGJC1	Joint connector
CGGJC2	Joint connector
CGGJC3	Joint connector
CGGJC4	Joint connector
CB11	Connection with BATTERY harness
CF91	Connection with FLOOR harness(RHD)
CGGIG	Connection with IGNITION COIL harness
CGGMT	Connection with MTM EXT. harness
E/R-CGG	Connection with E/R JUNCTION BOX harness
I/P-F	Connection with I/P JUNCTION BOX harness(RHD)
MC71	Connection with MAIN harness
MC81	Connection with MAIN harness
MC91	Connection with MAIN harness
GGG07	Ground
GGG08	Ground
GGG09	Ground
GGG10	Ground

**IGNITION COIL HARNESS**

CGG18-1	Ignition coil #1
CGG18-2	Ignition coil #2
CGG18-3	Ignition coil #3
CGG18-4	Ignition coil #4
CGGIG	Connection with CONTROL harness

**MTM EXT. HARNESS**

CGG50	Back-up lamp switch
CGG52	Vehicle speed sensor
CGGMT	Connection with CONTROL harness

# CONTROL HARNESS

## CONTROL HARNESS (G4GC) (3)

HL-9

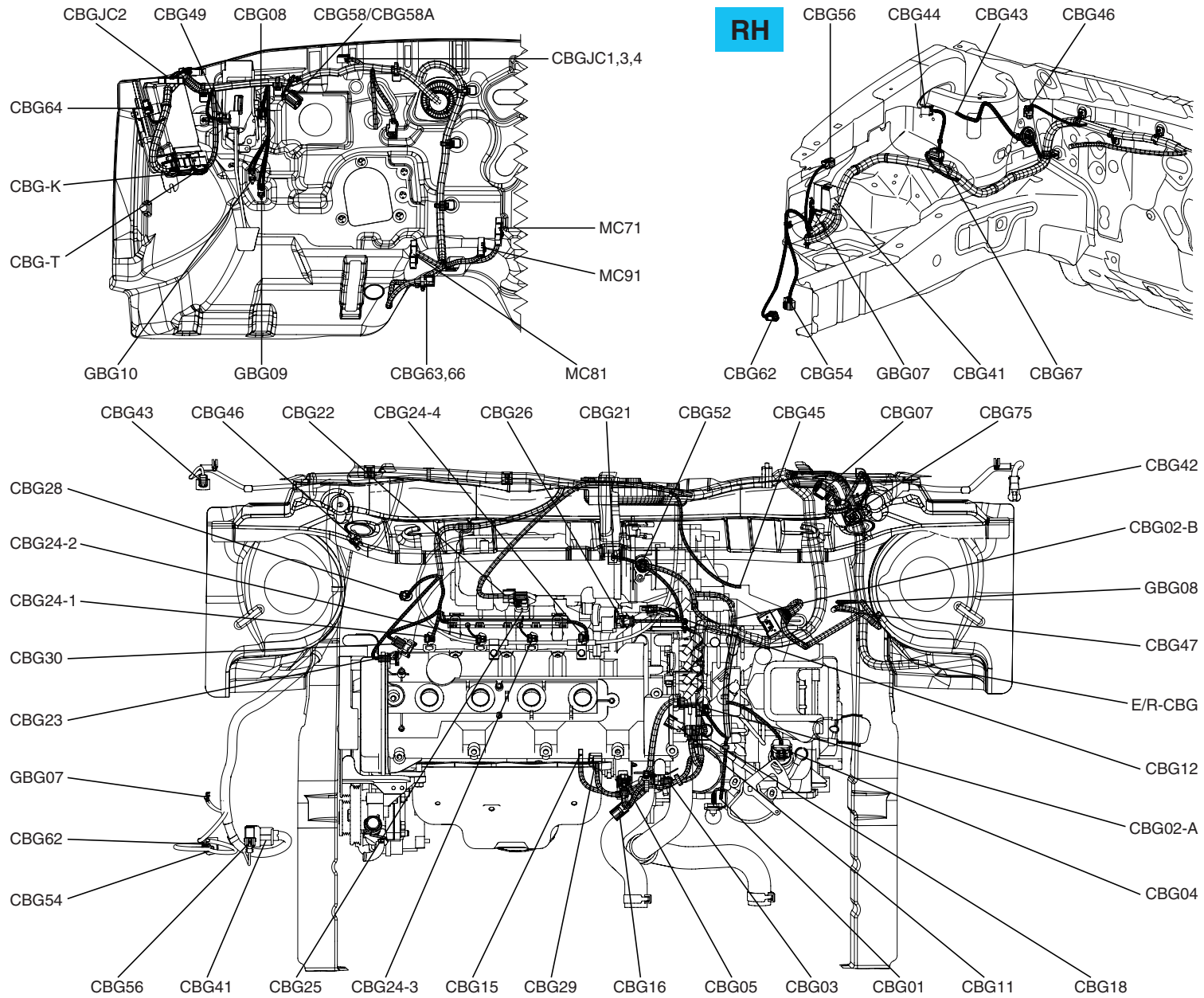



**CONTROL HARNESS****CONTROL HARNESS (G4GC) (4)****HL-10****CONTROL HARNESS**

CBG-K	ECM	CBG52	Vehicle speed sensor
CBG-T	TCM	CBG54	Front washer motor
CBG01	Transaxle range switch	CBG56	Hood switch
CBG02-A	Pulse generator 'A'	CBG58	Stop lamp switch(With cruise)
CBG02-B	Pulse generator 'B'	CBG58A	Stop lamp switch(W/O cruise)
CBG03	Oil temperature sensor	CBG59	Side repeater lamp RH
CBG04	ATM solenoid valve	CBG62	Washer level switch
CBG05	Oil control valve	CBG63	ATM lever switch
CBG07	Front wiper motor	CBG64	CAN resistor
CBG08	Ignition lock switch	CBG67	A/C pressure transducer
CBG11	Engine coolant temperature sensor & Sender	CBG75	Fuel cut sensor
CBG12	Throttle position sensor	CBGJC1	Joint connector
CBG15	Oil pressure switch	CBGJC2	Joint connector
CBG16	Oxygen sensor(Up)	CBGJC3	Joint connector
CBG18	Ignition coil	CBGJC4	Joint connector
CBG21	Purge control solenoid valve	CF91	Connection with FLOOR harness(RHD)
CBG22	Oxygen sensor(Down)	E/R-CBG	Connection with E/R JUNCTION BOX harness
CBG23	Knock sensor	I/P-F	Connection with I/P JUNCTION BOX harness(RHD)
CBG24-1	Injector #1	MC71	Connection with MAIN harness
CBG24-2	Injector #2	MC81	Connection with MAIN harness
CBG24-3	Injector #3	MC91	Connection with MAIN harness
CBG24-4	Injector #4	GBG07	Ground
CBG25	MAP sensor	GBG08	Ground
CBG26	Idle speed actuator	GBG09	Ground
CBG28	A/C compressor	GBG10	Ground
CBG29	Crankshaft position sensor		
CBG30	Camshaft position sensor		
CBG41	ABS control module		
CBG42	Front wheel sensor LH		
CBG43	Front wheel sensor RH		
CBG44	Cruise control module		
CBG45	Brake fluid level sensor		
CBG46	Burglar alarm horn		
CBG47	Multipurpose check connector		
CBG49	Cruise clutch pedal position switch		
CBG50	Back-up lamp switch		

# CONTROL HARNESS

## CONTROL HARNESS (D4FB) (5)

HL-11

LH

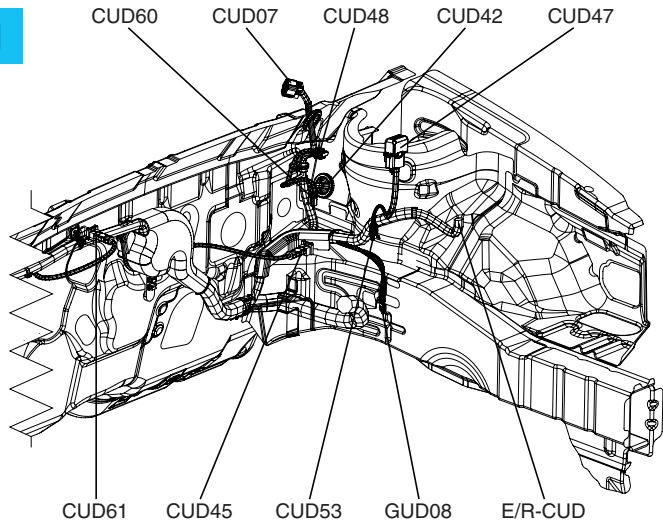

RH

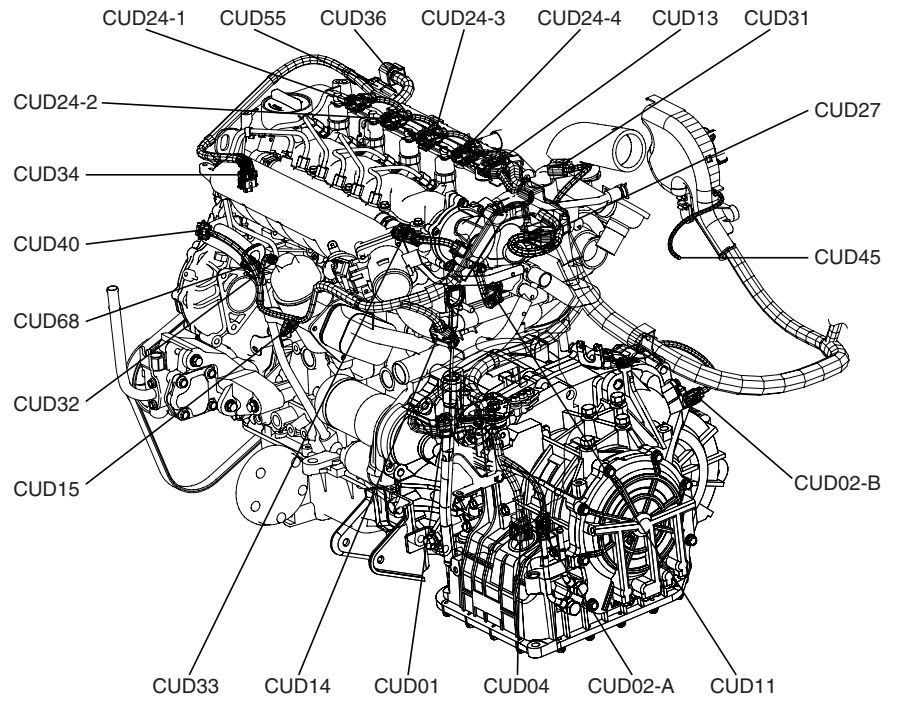
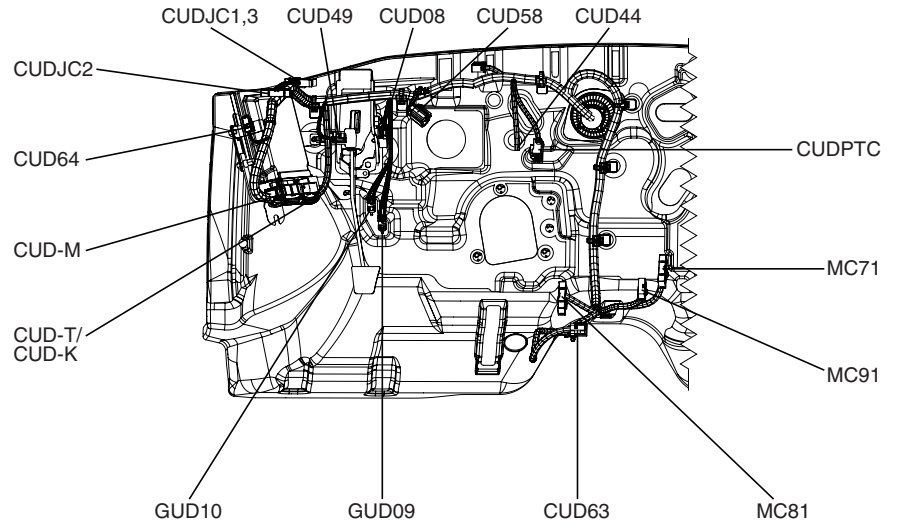
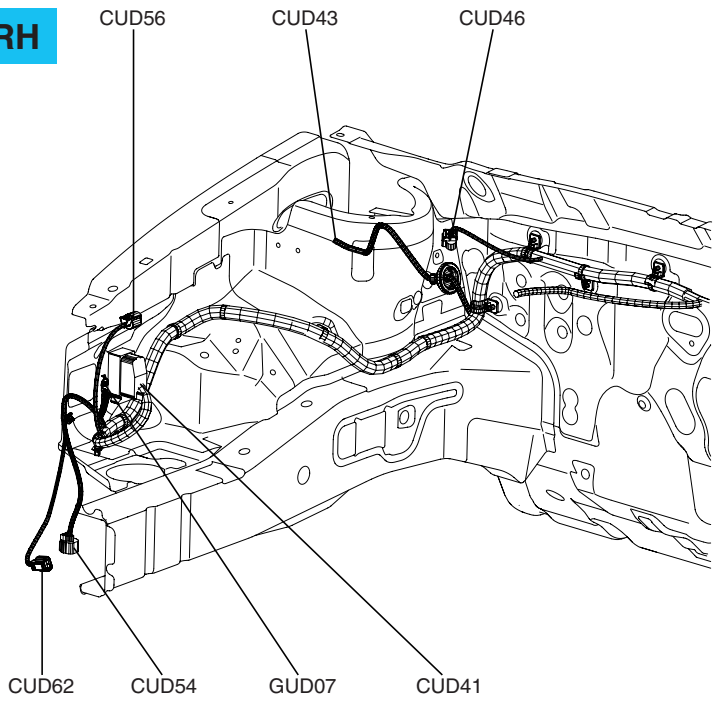

**CONTROL HARNESS****CONTROL HARNESS (D4FB) (6)****HL-12****CONTROL HARNESS**

CUD-K	ECM	CUD59	Side repeater lamp RH
CUD-M	ECM	CUD60	Thermo switch
CUD-T	TCM	CUD61	VGT actuator
CUD01	Transaxle range switch	CUD62	Washer level switch
CUD02-A	Pulse generator 'A'	CUD63	ATM lever switch
CUD02-B	Pulse generator 'B'	CUD64	CAN resistor
CUD04	ATM solenoid valve	CUD38	Fuel pressure regulating Valve
CUD07	Front wiper motor	CUD69	Fuel filter heater relay
CUD08	Ignition lock switch	CUD70	Glow plug relay
CUD11	Engine coolant temperature sensor & Sender	CUD71	PTC heater relay #1
CUD13	Camshaft position sensor	CUD72	PTC heater relay #2
CUD14	Crankshaft position sensor	CUD73	PTC heater relay #3
CUD15	Oil pressure switch	CUDJC1	Joint connector
CUD24-1	Injector #1	CUDJC2	Joint connector
CUD24-2	Injector #2	CUDJC3	Joint connector
CUD24-3	Injector #3	CF91	Connection with FLOOR harness(RHD)
CUD24-4	Injector #4	CUDMT	Connection with MTM EXT. harness
CUD27	Air flow sensor	CUDPTC	Connection with PTC HEATER harness
CUD31	EGR actuator	E/R-CUD	Connection with E/R JUNCTION BOX harness
CUD32	Fuel temperature sensor	I/P-F	Connection with I/P JUNCTION BOX harness(RHD)
CUD33	Rail pressure sensor	MC71	Connection with MAIN harness
CUD34	Rail pressure regulator	MC81	Connection with MAIN harness
CUD36	Lambda sensor	MC91	Connection with MAIN harness
CUD39	Boost pressure sensor	GUD07	Ground
CUD40	Variable swirl control actuator	GUD08	Ground
CUD41	ABS control module	GUD09	Ground
CUD42	Front wheel sensor LH	GUD10	Ground
CUD43	Front wheel sensor RH		
CUD44	Accelerator pedal sensor	<b>MTM EXT. HARNESS</b>	
CUD45	Brake fluid level sensor	CUD50	Back-up lamp switch
CUD46	Burglar alarm horn	CUD51	Neutral switch
CUD47	Multipurpose check connector	CUD52	Vehicle speed sensor
CUD48	Fuel filter heater	CUDMT	Connection with CONTROL harness
CUD49	Clutch switch		
CUD53	Fuel filter warning switch	<b>PTC HEATER HARNESS</b>	
CUD54	Front washer motor	CUD57	PTC heater
CUD55	Glow plug	CUDPTC	Connection with CONTROL harness
CUD56	Hood switch	GUD11	Ground
CUD58	Stop lamp switch		

**DOOR HARNESS** EDE013AD

**DOOR HARNESS (1)**

**HL-13**

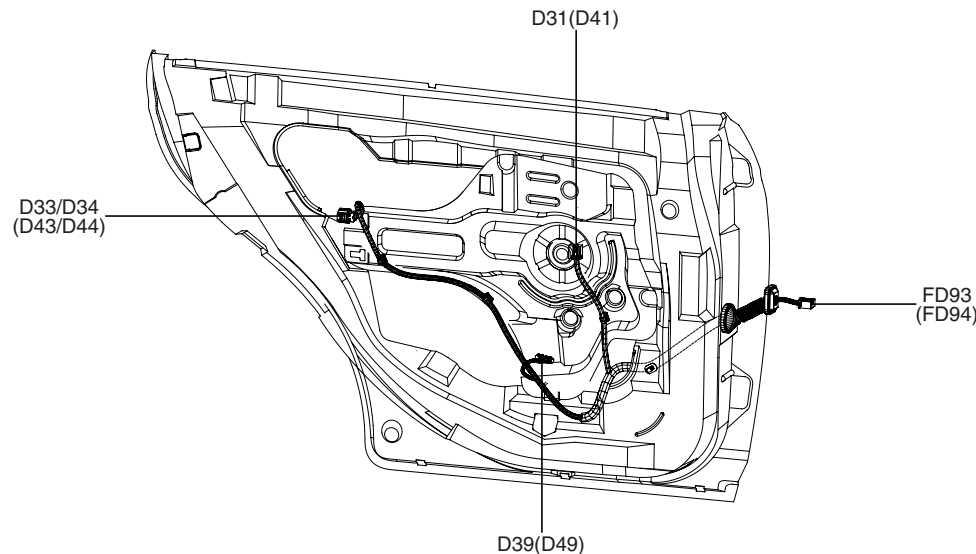
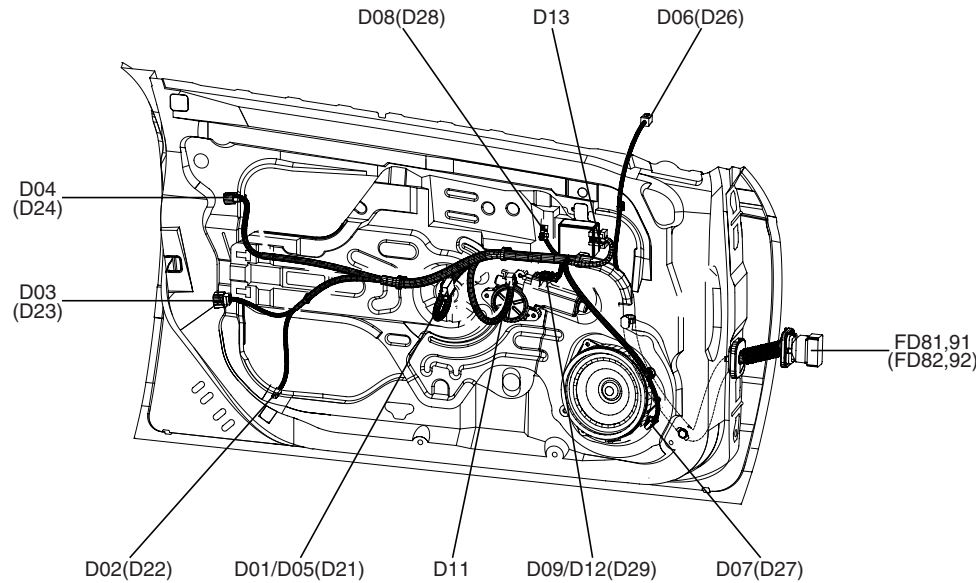

( ) : RIGHT

**DRIVER DOOR HARNESS**

- D01 Power window main switch
- D02 Driver door lamp
- D03 Driver door lock actuator
- D04 Driver door unlock switch
- D05 Safety power window switch
- D06 Driver power outside mirror motor
- D07 Driver door speaker
- D08 Driver tweeter speaker
- D09 Driver power window motor
- D11 Power outside mirror switch
- D12 Safety power window motor
- D13 Safety power window module
- FD81 Connection with FLOOR harness
- FD91 Connection with FLOOR harness

**PASSENGER DOOR HARNESS**

- D21 Passenger power window switch
- D22 Passenger door lamp
- D23 Passenger door lock actuator
- D24 Passenger door unlock switch
- D26 Passenger power outside mirror motor
- D27 Passenger door speaker
- D28 Passenger tweeter speaker
- D29 Passenger power window motor
- FD82 Connection with FLOOR harness
- FD92 Connection with FLOOR harness

**REAR DOOR LH HARNESS**

- D31 Rear power window switch LH
- D33 Rear door lock actuator LH(With burglar alarm)
- D34 Rear door lock actuator LH(W/O burglar alarm)
- D39 Rear power window motor LH
- FD93 Connection with FLOOR harness

**REAR DOOR RH HARNESS**

- D41 Rear power window switch RH
- D43 Rear door lock actuator RH(With burglar alarm)
- D44 Rear door lock actuator RH(W/O burglar alarm)
- D49 Rear power window motor RH
- FD94 Connection with FLOOR harness

TRUNK LID HARNESS E3E0DF4

TRUNK LID HARNESS (1)

HL-14

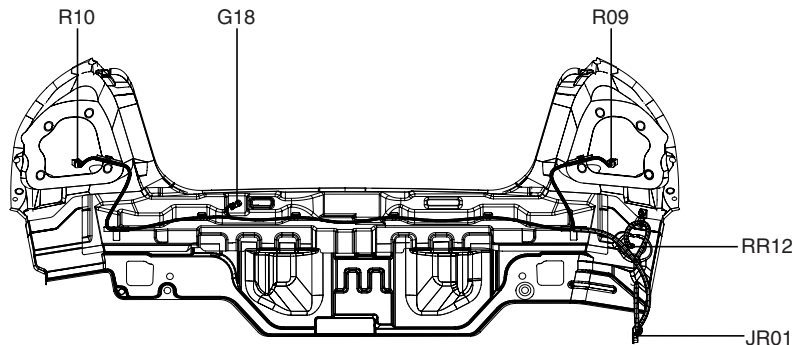
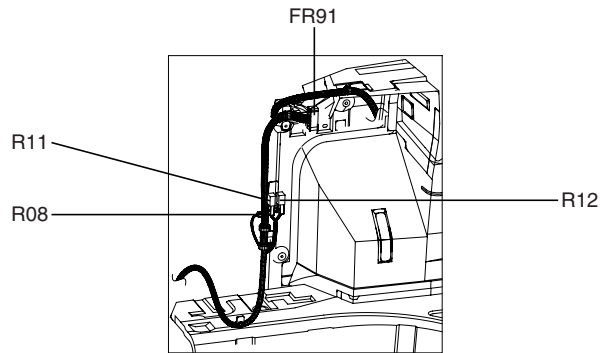
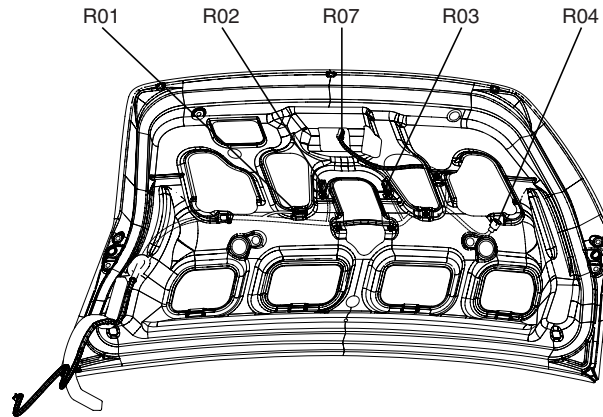

TRUNK LID HARNESS

- R01 High-mounted stop lamp(Spoiler)
- R02 License lamp LH
- R03 License lamp RH
- R04 Trunk unlock switch
- R07 Trunk lid actuator
- R08 Power antenna
- R09 Rear combination lamp LH(4DR)
- R10 Rear combination lamp RH(4DR)
- R11 Rear fog lamp relay(4DR)
- R12 Trunk lid open relay
- JR01 Joint connector
- FR91 Connection with FLOOR harness
- RR12 Connection with REAR FOG LAMP EXT. harness
- G18 Ground

REAR FOG LAMP EXT. HARNESS

- R37 Rear fog lamp RH
- RR12 Connection with TRUNK LID harness

TAIL GATE HARNESS E7BFBF9

TAIL GATE HARNESS (1)

HL-15

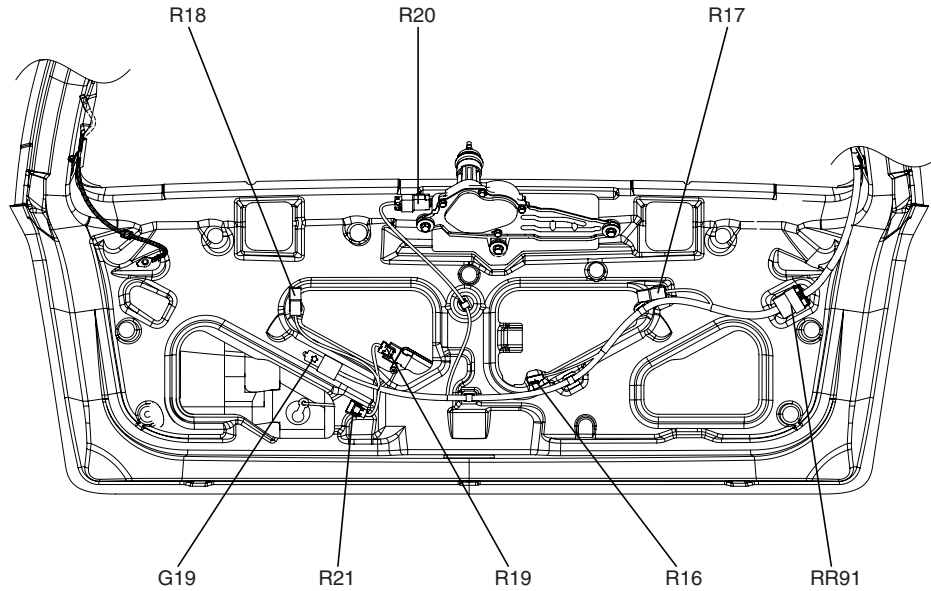

TAIL GATE HARNESS

- R16 Tail gate open switch
- R17 License lamp LH
- R18 License lamp RH
- R19 Tail gate lock actuator
- R20 Rear wiper motor
- R21 Tail gate unlock switch
- RR91 Connection with TAIL GATE EXT. harness
- G19 Ground

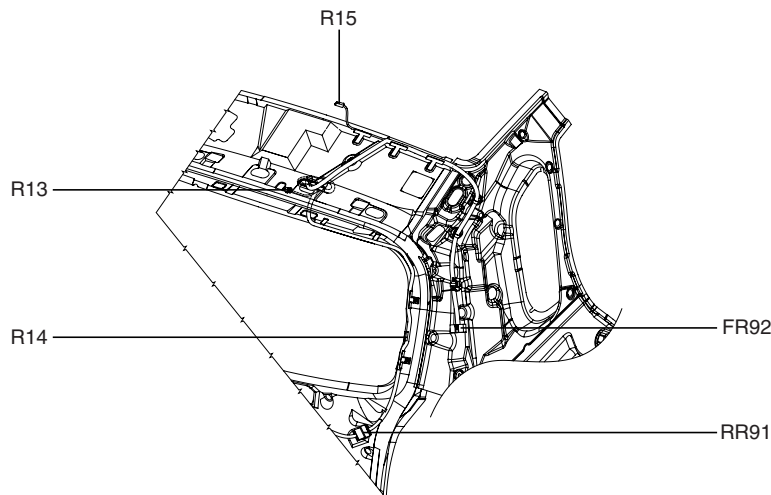

TAIL GATE EXT. HARNESS

- R13 High-mounted stop lamp
- R14 Rear defogger(5DR)
- R15 Roof antenna
- FR92 Connection with FLOOR harness
- RR91 Connection with TAIL GATE harness



ROOF HARNESS EA2794E9

ROOF HARNESS (1)

HL-16

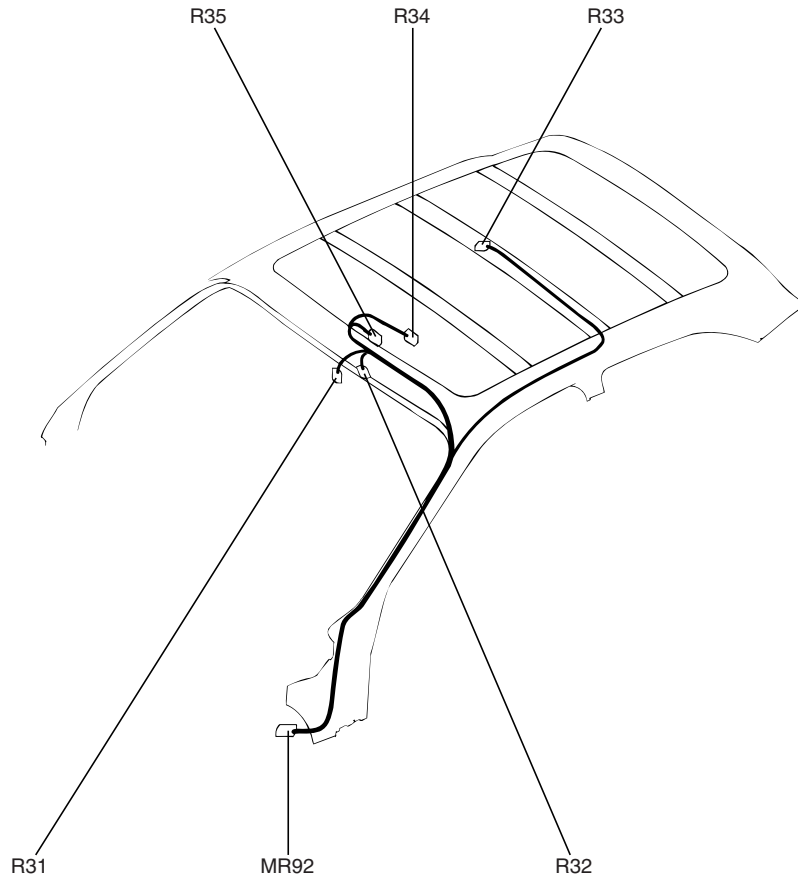

ROOF HARNESS

- R31 Electro chromic mirror
- R32 Map lamp(W/O overhead console)
- R33 Room lamp
- R34 Sunroof motor(With overhead console)
- R35 Sunroof switch(With overhead console)
- MR92 Connection with MAIN harness

A/C HARNESS EBA86E9E

A/C HARNESS (1)

HL-17

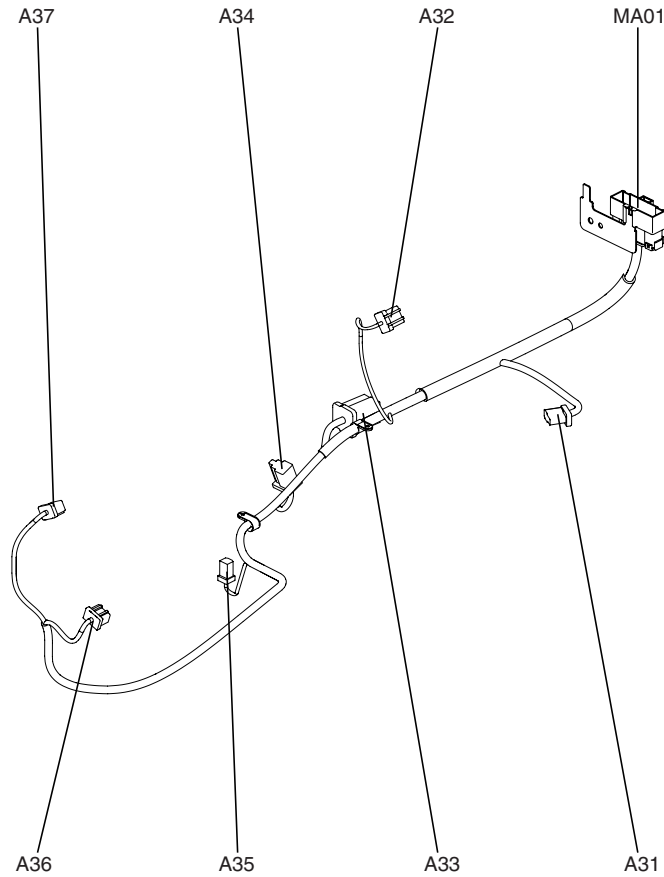

A/C HARNESS

- A31 Blower motor
- A32 Intake actuator
- A33 Blower relay
- A34 FET(Field-effect transistor)
- A35 Evaporator sensor
- A36 Temperature actuator
- A37 Mode actuator
- MA01 Connection with MAIN harness