

Technical Training of BESTURN B50

Automotive Technology Outline &
Diagnostic Apparatus Operation

Suitable Post: CTO

Curriculum Goals

- Familiar with the Configuration of BESTURN B50
- Know about the Automotive Technology & Configuration
- Be skilled in the Operation of the Diagnostic Apparatus

Contents



1. About B50

2. New Automatic Technology

3. Diagnostic Apparatus Operation

1.1 BESTURN Family Tree

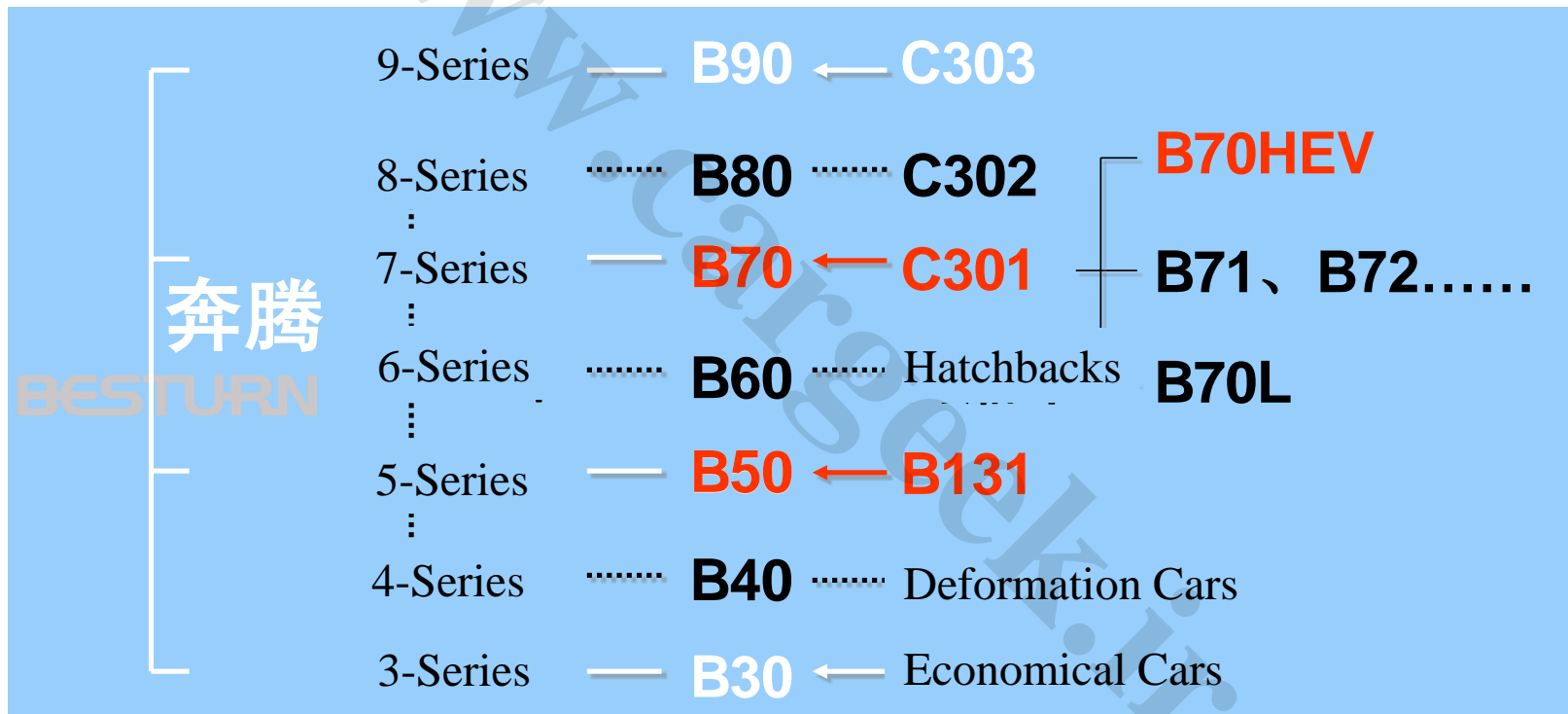

1.2.1 Appearance Design——New Honorable & Masculine



Powerful Beauty, Chinese-featured Beauty & Modern Beauty

1.2.2 Interior Style-New Refined Luxury



New Plain View.....Highlight the Noble & Elegant From Simplicity

1.3 Body Dimensions

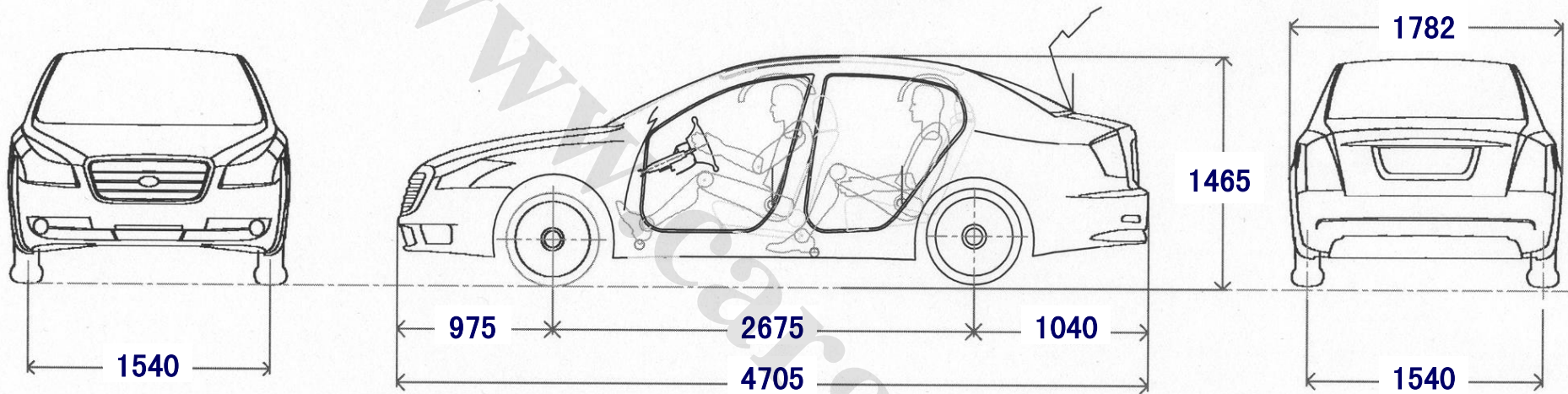

Compared Models	Length	Width	Height	Wheel Base
BESTURN B50	4600	1785	1435	2675

1.4.1 The Position of Vehicle Identification Number (VIN)

The Position of Vehicle Identification Number (VIN):

- On the inner left of front windshield ;
- Under the floor of passenger's side seat



1.4.2 The Meaning of Vehicle Identification Number (VIN)

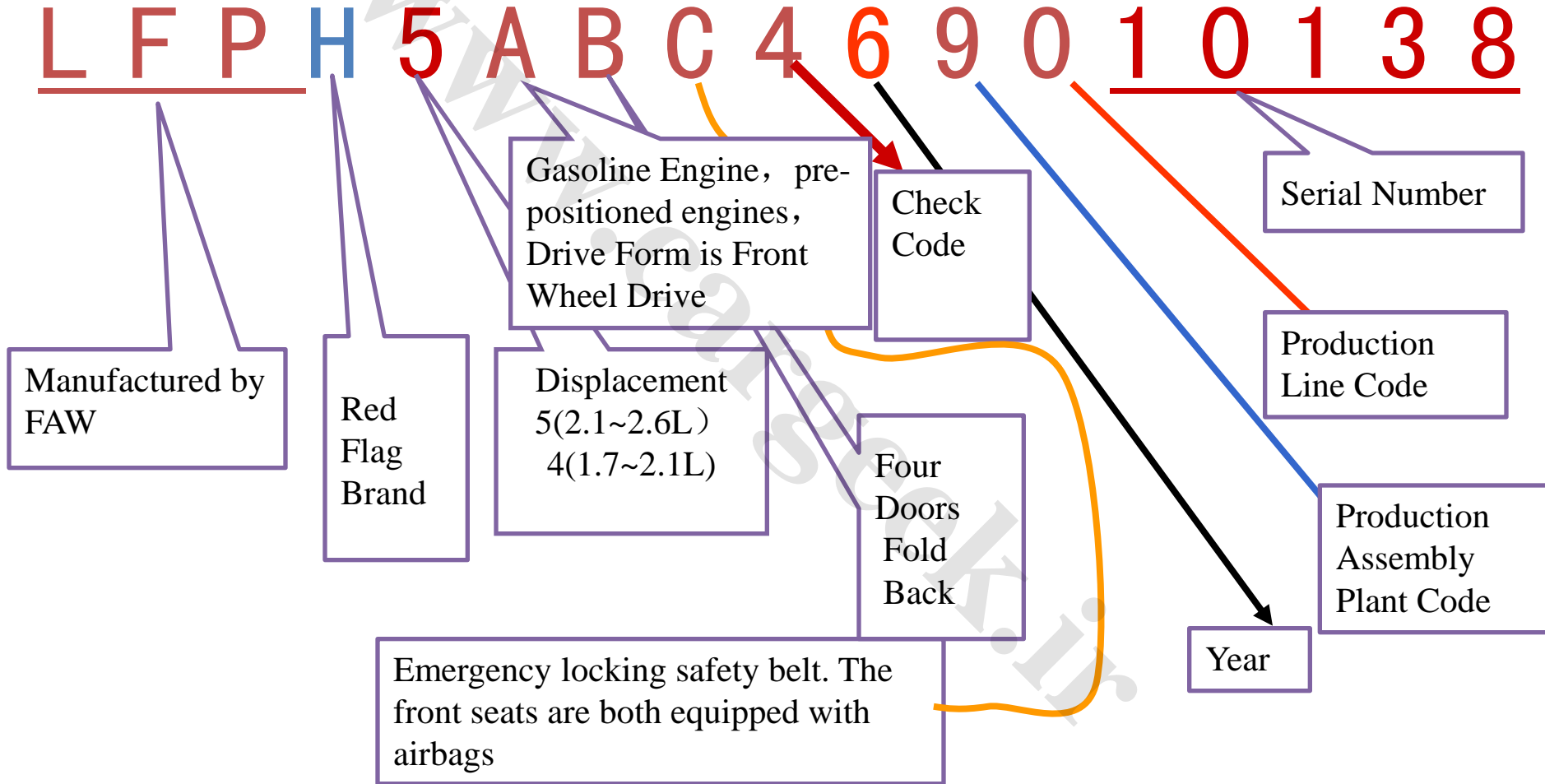

1.5 Basic Configuration of B50

The Parameters Table of the Equipment of BESTURN B50 of Year 2011

	DLX MT	DLX AT	VTI-S MT	VTI-S AT	3G AT
Dimension Parameters					
Length/Width/Height (mm)	4600/1785/1435				
Wheel Base (mm)	2675				
Fluid Tank Volume (L)	58				
Car Trunk Volume (L)	450				
Engine					
Maximum Engine Power (kW/rpm)	76/5600				
Maximum Engine Torque (N.m/rpm)	145/3800				
Gearbox					
Gearbox	5MT	6AT	5MT	6AT	6AT
Chassis System					
Front Suspension Form	Double wishbone independent front suspension with a stabilizer bar				
Rear Suspension Form	E-type multi-link independent rear suspension with a stabilizer bar				
Steering System	Speed sensing rack and pinion steering gear				
Braking System	Front and rear wheel disc brake				
Emission Standard	National IV				
Wheels	195/65R15				

1.6 Vehicle Lifting Point

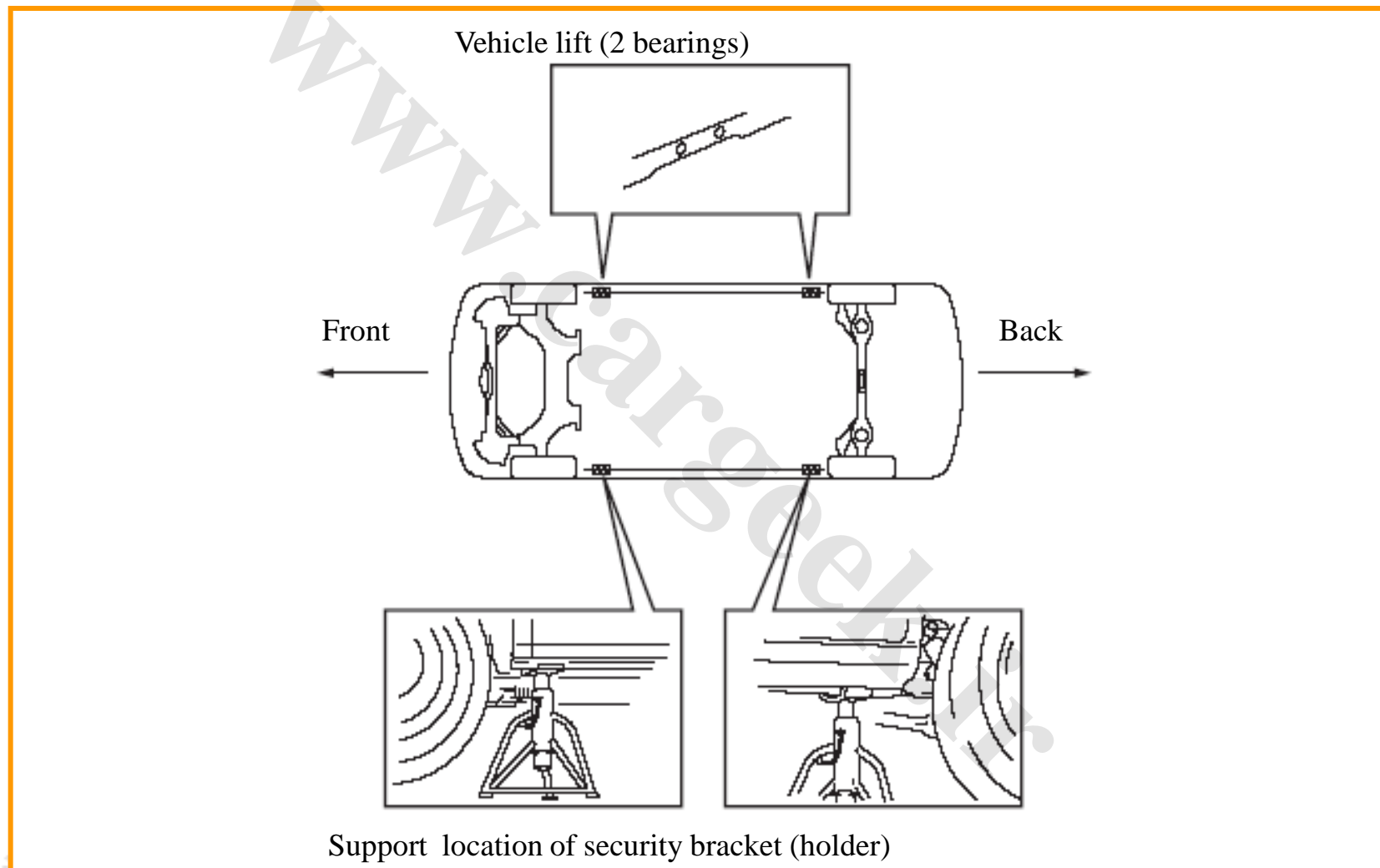

1.7 Maintenance

Maintenance Interval	The Earlier Arriver Between the Month & the Kilo																
	Month	6	12	18	24	30	36	42	48	54	60	66	72	78	84	90	96
	×1,000KM	10	20	30	40	50	60	70	80	90	100	110	120	130	140	150	160
Engines																	
Valve Clearance of Engines		Check audible voices every 120,000 km, if there is a noise, please change															
Engine Oil*1		Change every 5,000km or 6 months															
Oil Filter*1		Change every 5,000km or 6 months															
Transmission Belt*2		I	I	I	I	I	I	I	I	I	I	I	I	I	I	I	I
Cooling System																	
Cooling System		I		I		I		I		I		I		I		I	
Engine Coolant	FL22*4										R						
	Other types	Change every 2 years															
Fuel System																	
Fuel Filter		Change every 10,000km or 12months															
Air Filter Original*3			C		R		C		R		C		R		C		R
Fuel Pipelines & Hoses			I		I		I		I		I		I		I		I
Ignition System																	
Spark Plug		Change every 100,000km															
Emission Control System																	

Continued Table

www.CarGeek.ir

The Earlier Arriver Between the Month & the Kilo

Maintenance Interval	The Earlier Arriver Between the Month & the Kilo																
	Month	6	12	18	24	30	36	42	48	54	60	66	72	78	84	90	96
	× 1,000 km	10	20	30	40	50	60	70	80	90	100	110	120	130	140	150	160
Evaporation System (if equipped)		1			1		1		1		1		1		1		1
Electrical System																	
Storage Battery Electrolyte Position & Proportion		1			1		1		1		1		1		1		1
All The Electronic Systems*6		1			1		1		1		1		1		1		1
Chassis & Body																	
Brake Lines, Hoses & Connection		1			1		1		1		1		1		1		1
Braking Fluid*5	1	1	1	R	1	1	1	R	1	1	1	R	1	1	1	1	R
Parking Brake	1	1	1	1	1	1	1	1	1	1	1	1	1	1	1	1	1
Power braking device& Hoses		1			1		1		1		1		1		1		1
Disc Brake	1	1	1	1	1	1	1	1	1	1	1	1	1	1	1	1	1
Power Steering Fluid, Pipelines & Connection	1	1	1	1	1	1	1	1	1	1	1	1	1	1	1	1	1
Steering Operation & Connection		1			1		1		1		1		1		1		1
manual transmission drive axle oil	Change every 60,000km or 2 years																
The Oil Level in Automatic Gearbox		1			1		1		1		1		1		1		1
Front Suspension, Back Suspension & Ball Joint					1				1				1				1
Dust Cover Of Transmission Shaft					1				1				1				1
Chassis & Bolt and Nut on the Body		T			T		T		T		T		T		T		T
Exhaust System & Heat Insulation	Change every 80,000km																
Body Status (rusting, Corrosion & Perforation)	Please check annually																
Tyres (including Spare Tyres with the Adjustment of Tyre Pressure)		1			1		1		1		1		1		1		1
Air Conditioning System (if equipped)																	
Air Filter (if equipped)		R			R		R		R		R		R		R		R

www.cargeek.ir

2.1 B50 Mature Power-Economically Affordable



BWH 1.6L Engine Technical Highlights

- German Siemens Electric Control System
- Variable Induction System
- Heating Function of Cool Air
- Secondary Air Pump
- The Reverse Arrangement of Intake and Exhaust
- Engine Hydraulic Floating Valve Support

2.2 Automatic Gearbox

B50 intelligent 6-Speed Auto/Manual Integrated Automatic Gearbox



Torque Volume	200 N.m	
Overall Length	349.5 mm	
Gross Weight	83.5kg (including gear oil)	
Maximum Input Speed	6500 rpm	
Minimum Idling Speed	700rpm (D Grade)	
Speed Ratio (200N.m spec)	1-Grade	4. 148
	2-Grade	2. 370
	3-Grade	1. 556
	4-Grade	1. 155
	5-Grade	0. 859
	6-Grade	0. 686
	Reverse Gear	3. 394

2.3 Chassis System

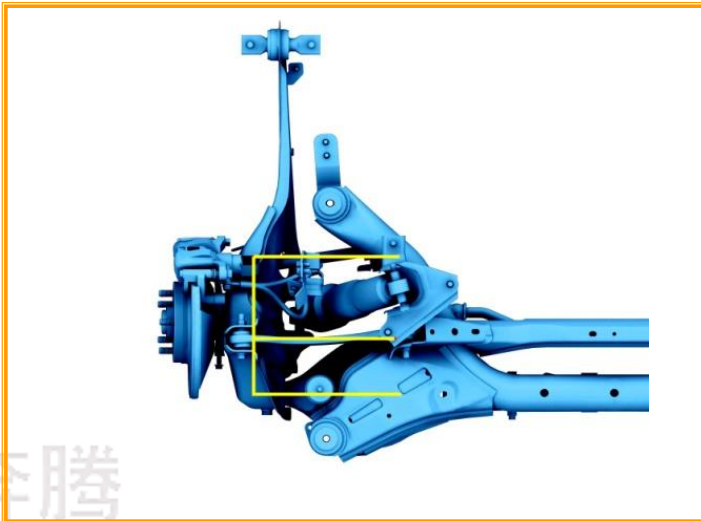

- Speed Sensing Rack & Pinion Steering Gear
- Angle & Height Adjustable Steering Column
- E-type Multi-link Rear Suspension, Rear Wheel Toe-in, Extraversion Adjustable
- 205/55R16 91V Standard Aluminum alloy tyres
- ABS+EBD+TCS+EBA
- Using Dynamic Stability Control (DSC)

2.4 Body System



- Six Airbags at the Front Seats
Main airbag + Seat side + Side curtain airbags
- Front and rear passenger seats are equipped with three-point seat belts with the functions of ELR(Emergency Locking Seat Belt Retractor; Emergency Locking Mechanism), pre-tension device seat belts and load limiters.

2. New Automatic Technology

www.CarGeek.ir

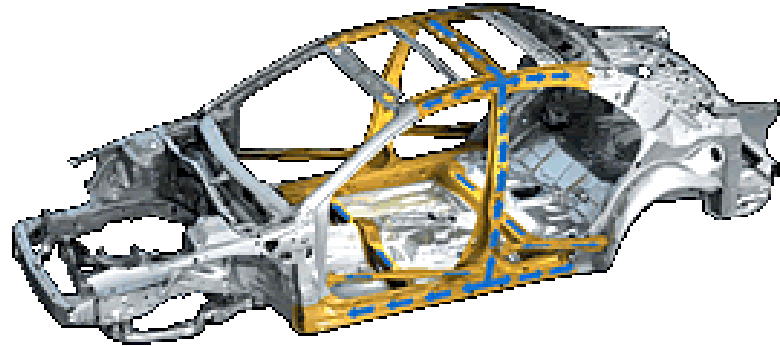

Body Systems

- Triple H body structure
- Xenon headlamps (with light adjustment, headlight washer device)
- All-electric outside rearview mirrors (with power folding and electric heating)



奔腾 BESTURN

www.cargeek.ir

2. New Automatic Technology

www.CarGeek.ir



Body Systems

- Automatic constant temperature air conditioning with exterior temperature display
- Eight-direction power adjustable driver seat (with memory function)
- Intelligent inside rearview mirror (electronic anti-dazzling, compass and reversing radar display)



奔腾 BESTURN

www.cargeek.ir

2. New Automatic Technology

www.CarGeek.ir



Body Systems

- Electric door lock system and advanced remote keyless entry system
- Built-in PCM passive anti-theft system, PATS
- Advanced CAN network system
- Many humanity designs

奔腾 BESTURN

www.cargeek.ir

2.5 CAN Network Control of the Entire Car

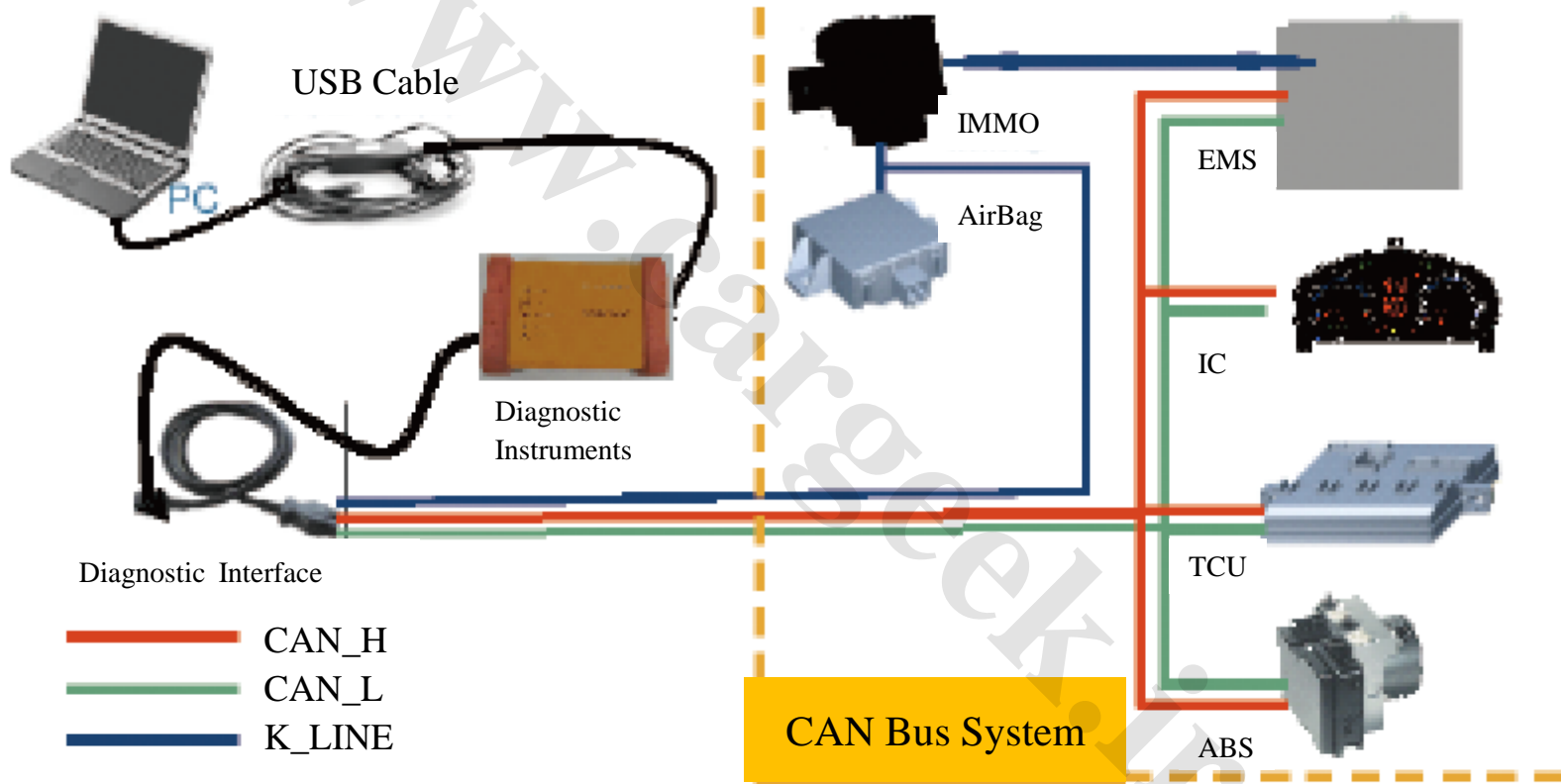

2.6 Automatic Tire Pressure Warning System



Automatic Tire Pressure Warning System

The tire pressure warning retains the combined instrumental warning lights. The inside rearview mirror gives a warning signal through comparing received temperature and pressure information with the set standard parameter information. Timely alarms can improve driving safety.

2.7 A Variety of Network Life

A Variety of Network Life



3G

AUTO LIFE

The third generation of automotive digital multimedia system

(3G AUTO LIFE)

GPS satellite navigation: covering the latest map data of almost all locations, and especially customized 4S shop landmarks for national service of FAW Pentium users to provide you with a convenient navigation service full-time all-round;

GPRS communication subsystem: standard 2.75G and compatible with a generic module in 2.5G market to achieve the interconnection of mobile network information. It can even connect to 3G era step by step according to the advance of 3G technology market and network coverage;

Gigabyte entertainment devices with mass storage: In addition to mass storage of audio and video files, BESTURN B50 Digital Multimedia Subsystem also has functions of radio, mobile TV, MP3/MP4 multi-format compatible player, electronic albums and books, etc., also compatible with streaming media, so that Internet becomes a program library, allowing you to enjoy the entertainment on board.

Updated, faster, more audio-visual enjoyment and high-speed interactive information gives you unprecedented convenience, fully mobile space, and an ideal for intelligent control of the world.

3. Diagnosis Instrument Operation

3.1 Integrated -Type (Laptop) Diagnostic Apparatus

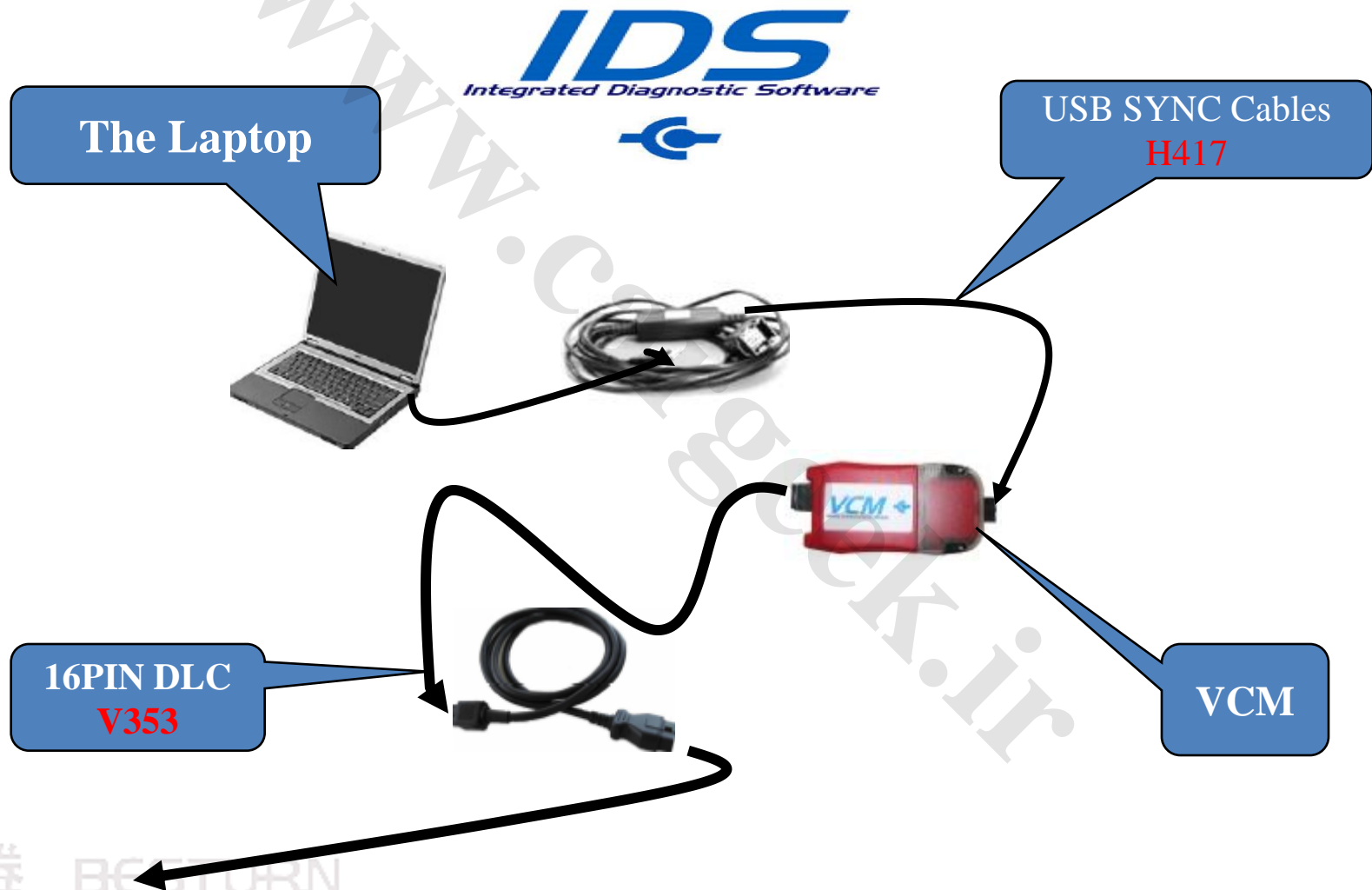

The Laptop

USB SYNC Cables
H417

16PIN DLC
V353

VCM

3. Diagnosis Instrument Operation

3.2 The Connection & Set up of IDS

- Install IDS software in a notebook
- Turn off the ignition switch
- Select the cables and connect them as the previous page has shown. *You can only use the H417 cable, the use of H352 cable prohibited.*
- Turn on the ignition switch
- After VCM self-test, if the 1st, 3rd, 5th LED indicator lights are on and the 2nd LED is flashing, the communication is normal, if not, you have to reconnect them, if the 1st light is off, then check the cable V353, and if the 5th light is off, check the cable H417.

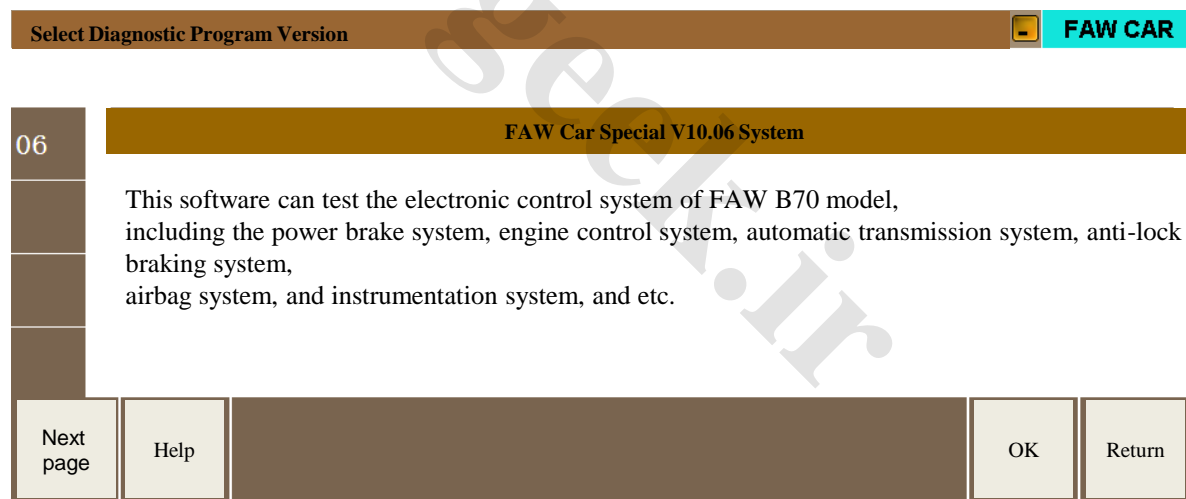

3. Diagnosis Instrument Operation

3.3.1 Network Testing

Network Testing: Check the entire vehicle to see which ECUs are equipped and how they respond.

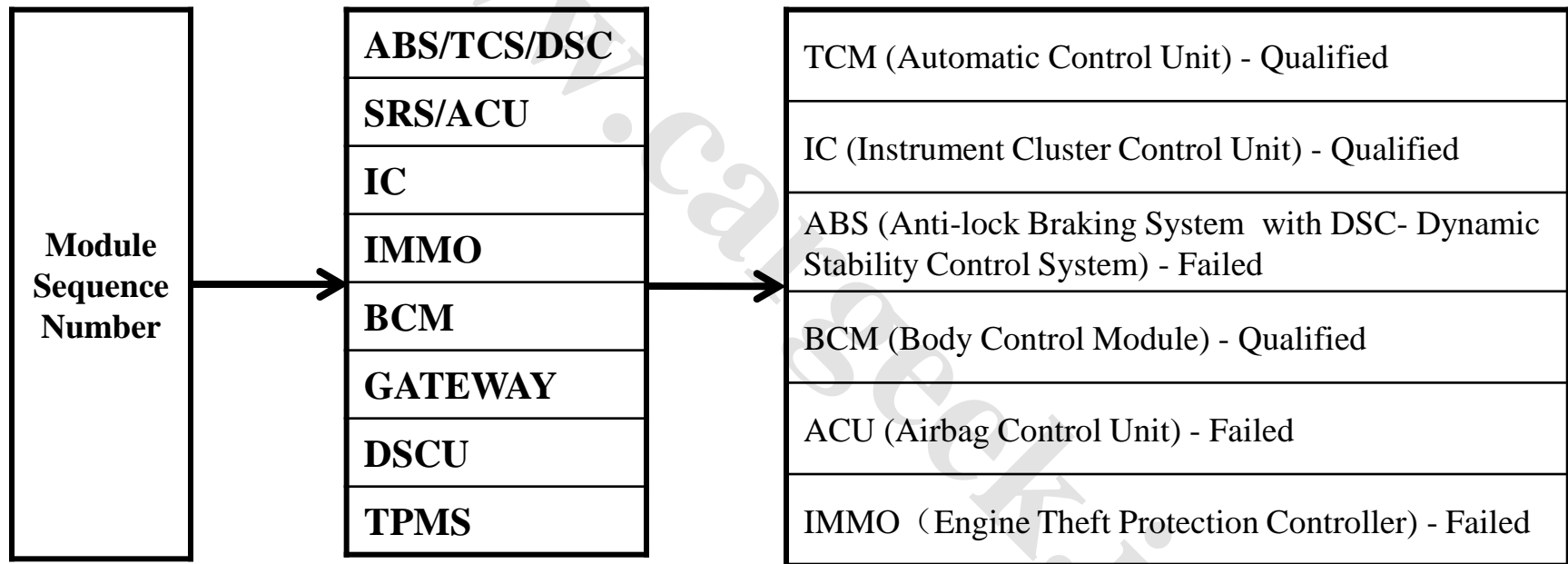

3. Diagnosis Instrument Operation

3.3.2 Self-testing: Check and Clear the Fault Code of Each Module

F-ADS	Self-testing
	PCM (Engine Control Unit)
	TCM (Automatic Gearbox Control Unit)
	ABS (Anti-lock Braking System with DSC- Dynamic Stability Control System)
	ACU (Airbag Control Unit)
	IC (Instrument Cluster Control Unit)
	BCM (Body Control Module)
	GATEWAY (Gateway Control Unit)
	IMMO (Engine Theft Protection Controller)
	DSCU (Seat Memory Control Unit)
	TPMS (Tire Pressure Monitoring System)
	All of the CMDTCs



- Self-test
- Data Logger
- Active Testing
- Module Programming
- Network Testing
- Module Serial Number
- Body - Safety
- Chassis
- Powertrain
- Vehicle Health Check

3. Diagnosis Instrument Operation

3.3.3 Data Logger

Data Logger : Read the Data Streams of Various Modules

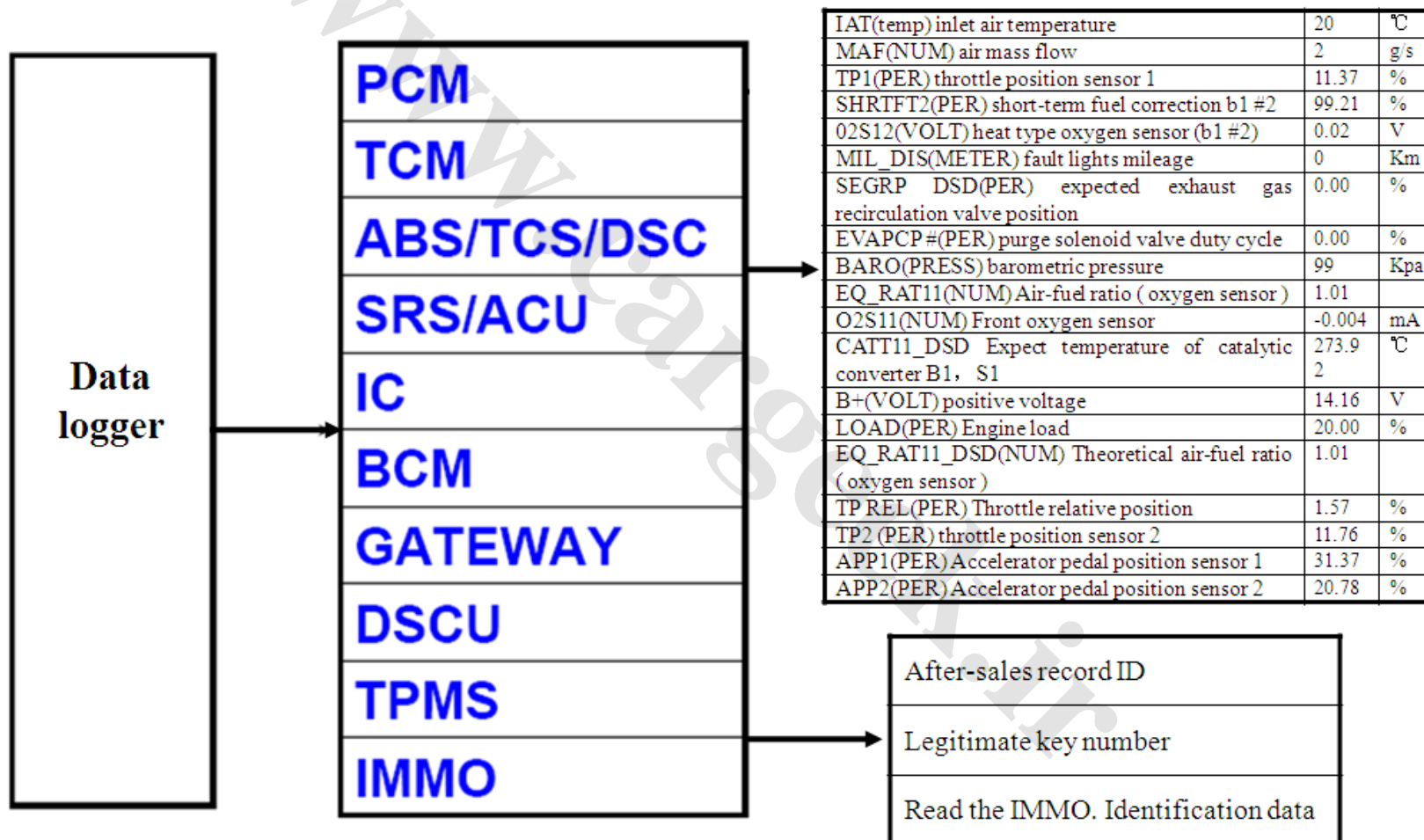

3. Diagnosis Instrument Operation

3.3.4 Active Testing

Active Testing : Make diagnostic apparatus send out instructions artificially, activating the actuator.

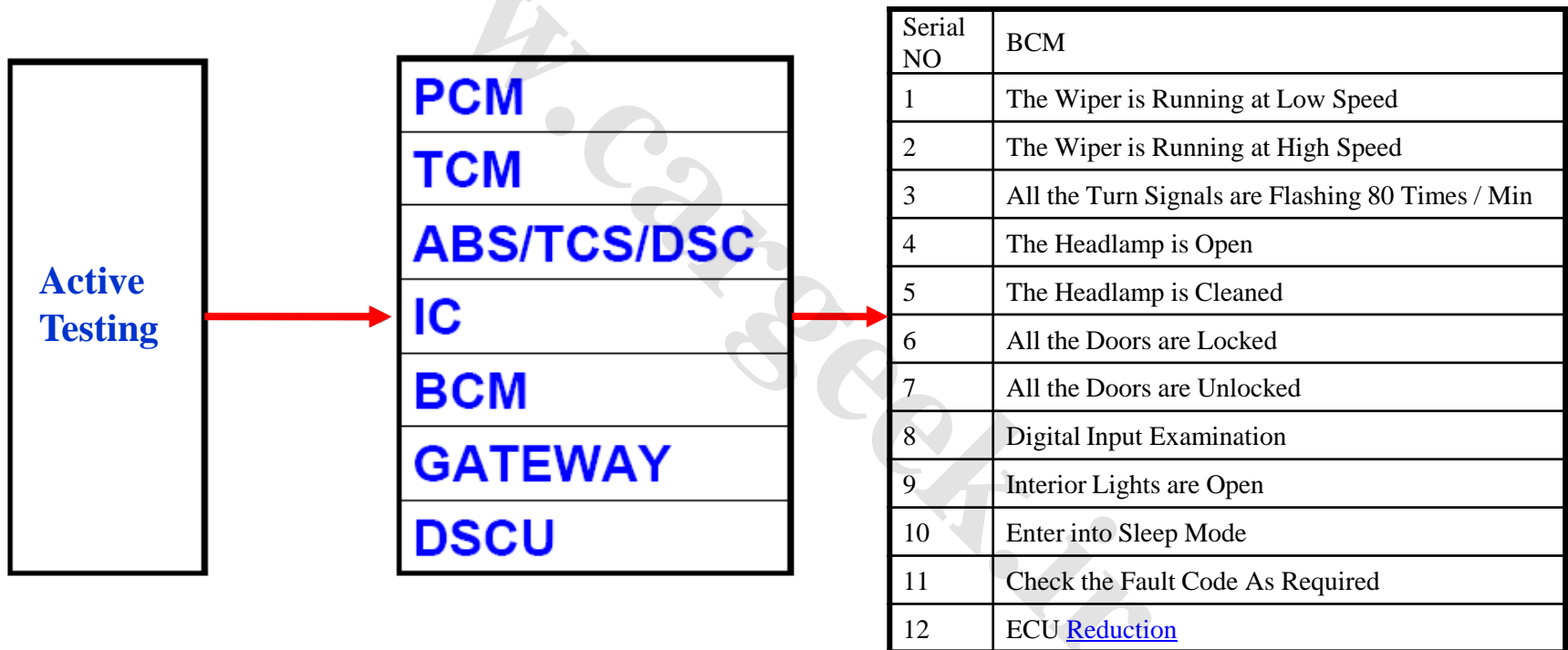

3.3.5 Module Programming

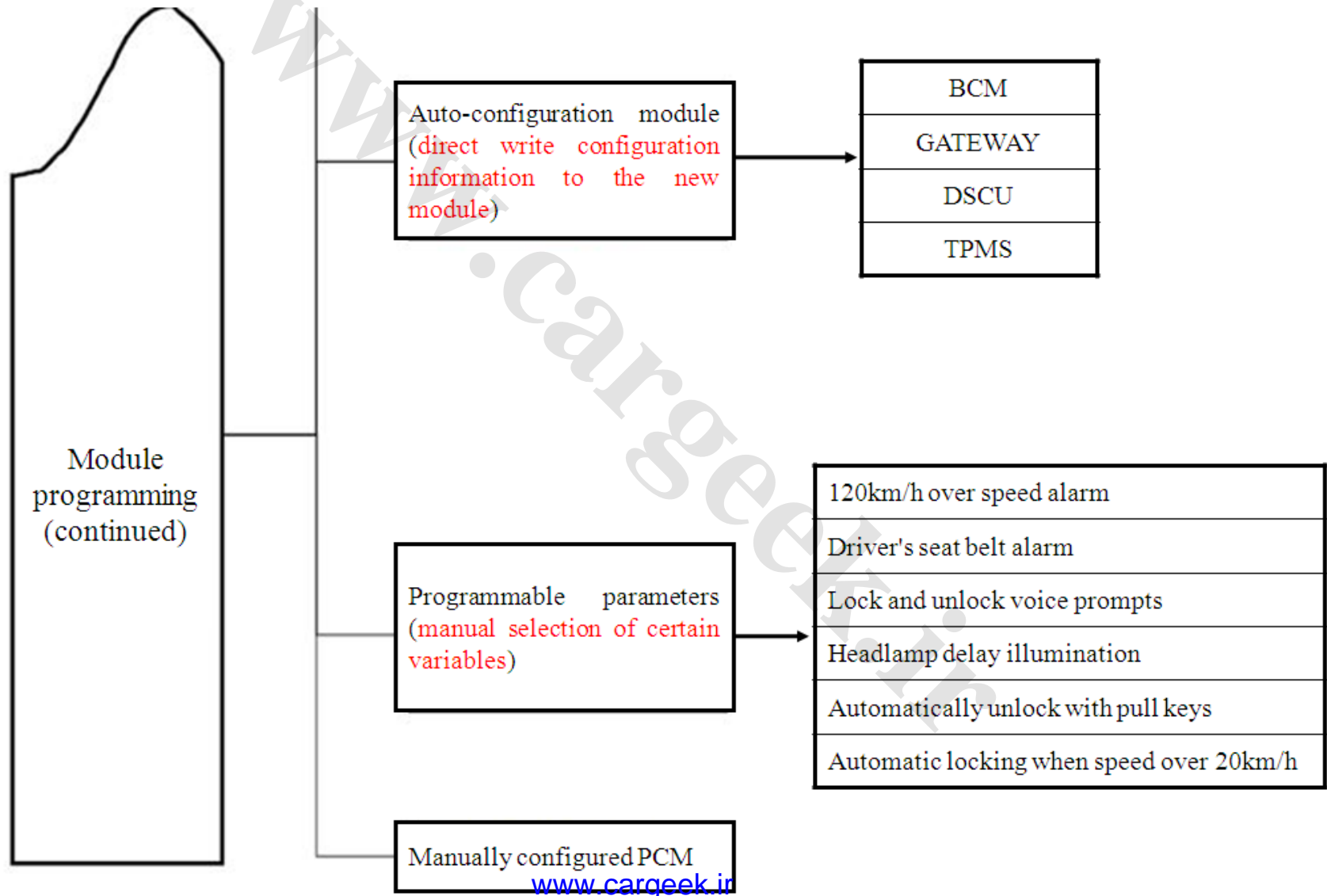

www.cargeek.ir
Thank you!

奔腾 BESTURN

Technical Training of BESTURN B50

— Mechanical Part of Engine

Curriculum Goals

- Comprehend 1.6 Engine BWH performance
- Master the basic adjustment of the engine
- Comprehend the structure of the engine
- Be Familiar with the basic data and methods of maintenance

Contents



1.Outline of the engine

2.Timing Marks and Installation of the Engine

3.Cylinder Head of the Engine

4.Cylinder Block of the Engine

5.Lubricating System of the Engine

6.Cooling System of the Engine

1.1 Morphological Structure of the Engine



Engine BWH

1.2 Location of the Engine's Number

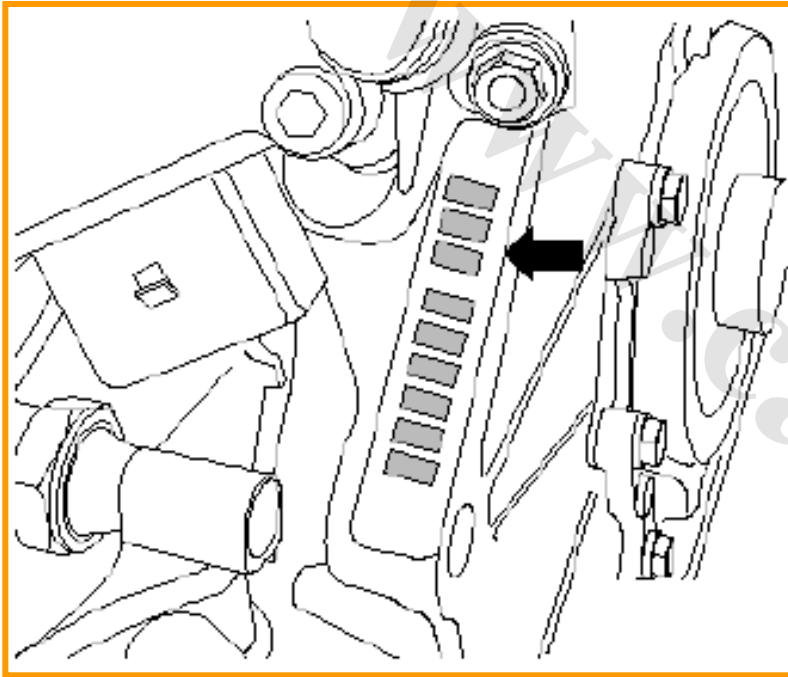

Engine BWH

1.3 Engine Performance Curve



1.6 Engine BWH

1.4 Technical Parameters of Engine BWH

Labelled letter	BWH
Emission standard	EU4
Displacement	1.595
Power	74/6000
Twisting moment	145/3800
Cylinder bore	81
Stroke	77.4
Compression ratio	10.3-10.5
Number of valves per cylinder	2
ROZ	Lead-free No.95\93
EGR	N
Gas switch	Y
Secondary air system	Y
Electronic throttle valve	Y

1.5 Transmission Band of the Engine

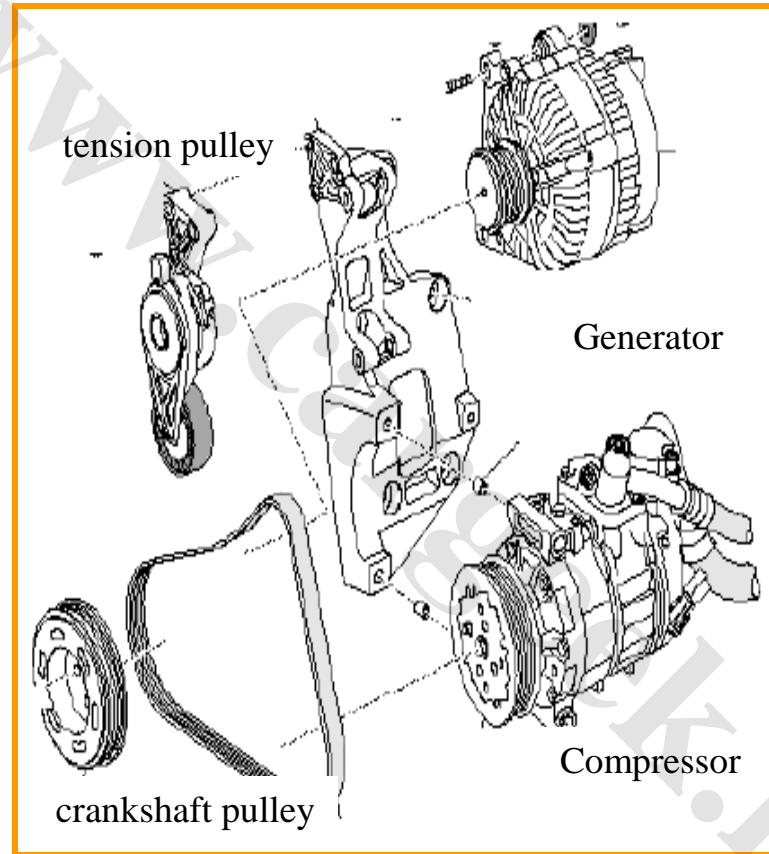

BWH

2.Fitting Marks of Timing Chain BWH

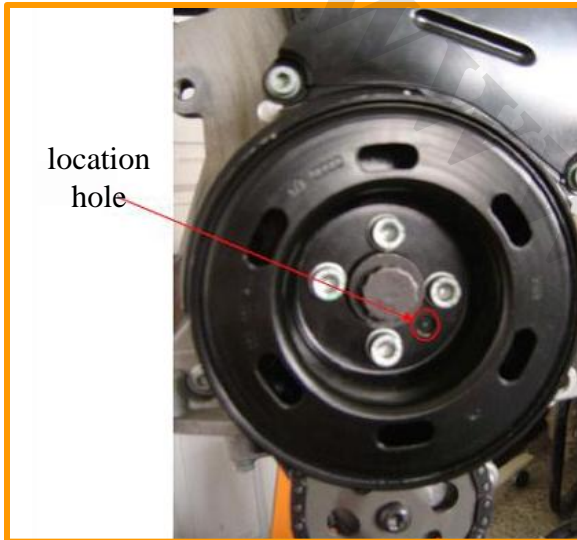

- Locate the positioning holes on the crankshaft pulley.
- Set the crankshaft of the damper at the locking position of Cylinder 1.
- It must be aligned with-arrow-.
- Fix the timing gear of the camshaft on the crankshaft to the TDC of Cylinder 1.
- The timing gear mark of the camshaft must be aligned with the arrow of the toothed belt guard.

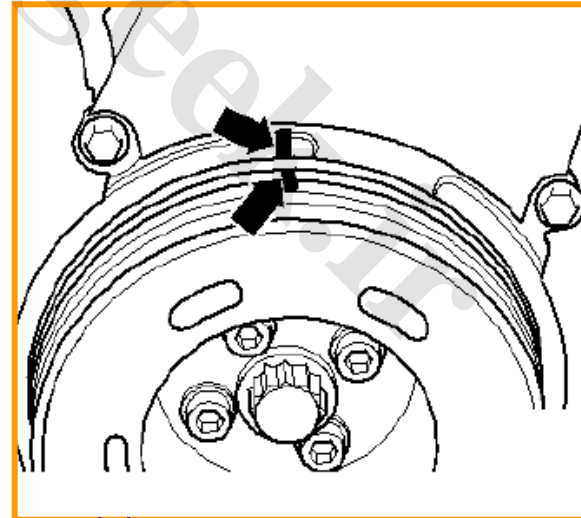
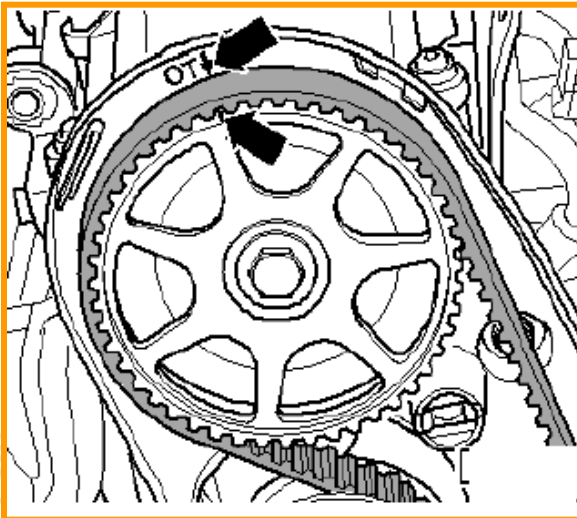

3.1 Structure and Maintenance of Cylinder Head BWH

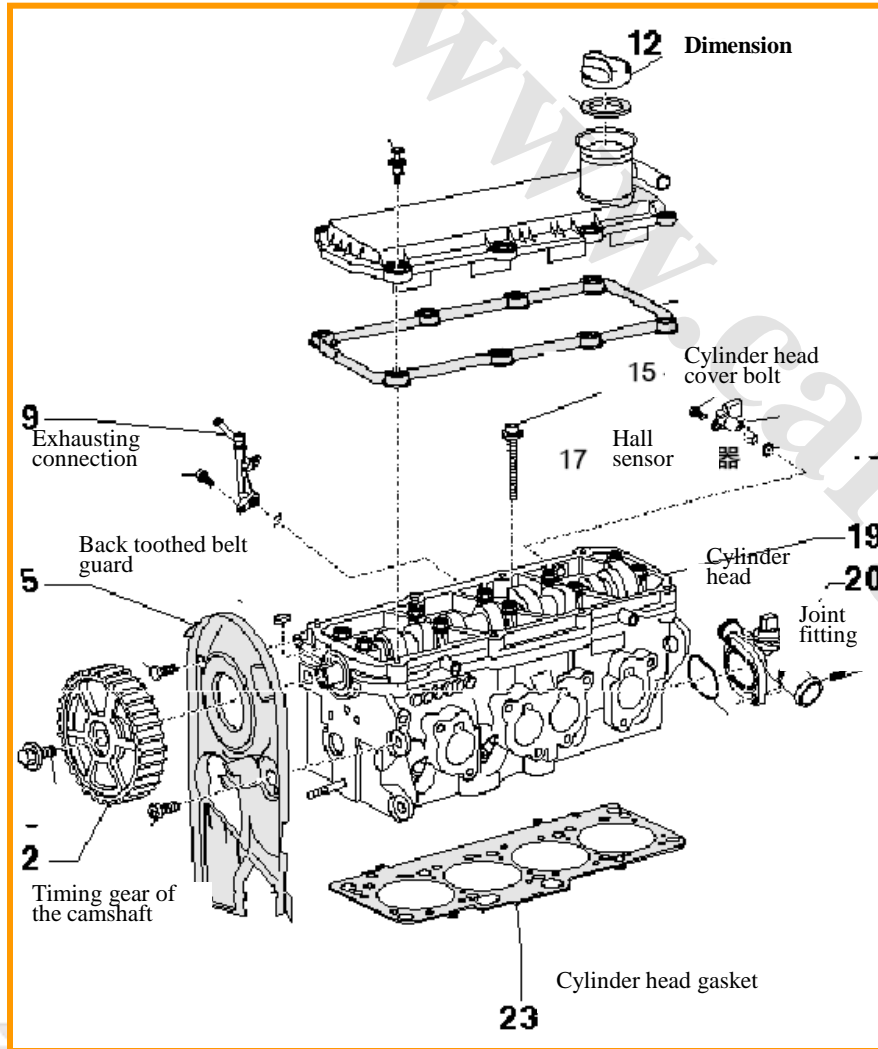

- 2 – Timing gear of the camshaft
- 5 – Back toothed belt guard
- 6 – Flat key
- 9 - Exhausting connection
- 12 – engine oil fill cap
- 13 - Cylinder head cover
- 14 – Seal of the cylinder head cover
- 15 – Cylinder head cover bolt
- 17 - Hall sensor -G40-
- 19 – Cylinder head
- 20 – Joint fitting
- 23 - Cylinder head gasket

3. Cylinder Head of the Engine

3.2 Inspect the Deformation of the Cylinder Head

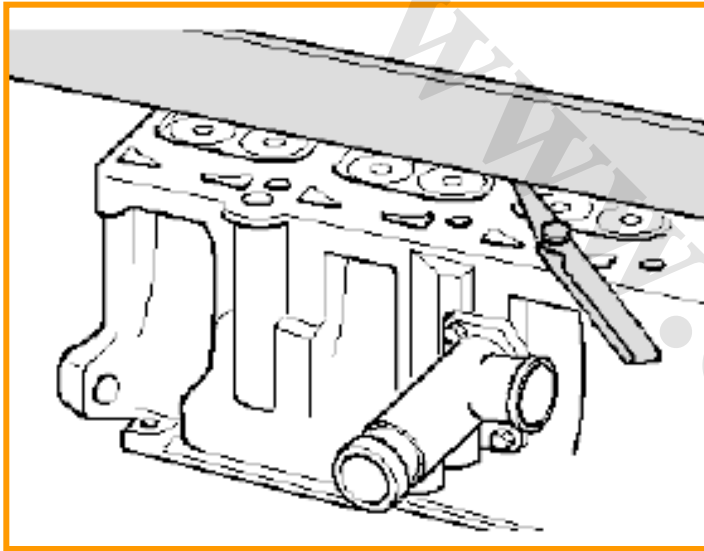

The engine is allowed up to the hand warm temperature when tightening the cylinder head, or the cylinder head will be distorted.

The maximum deformation allowed: 0.05 mm

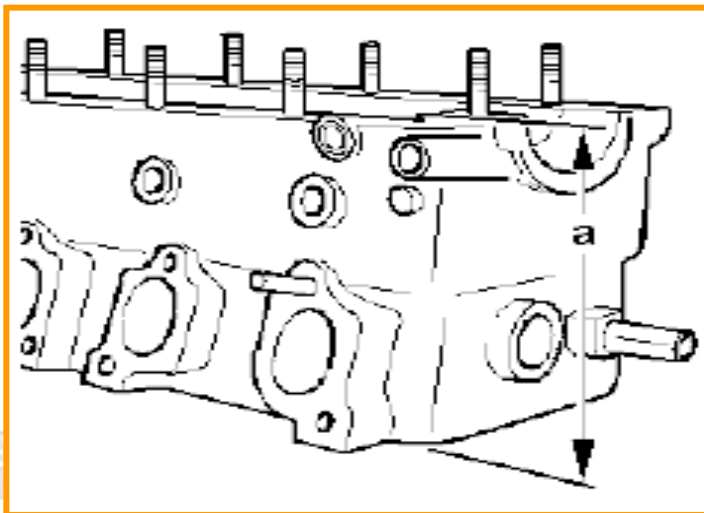

The maintenance of the cylinder head sealing surface

Trimming size of the cylinder head:

$a =$ at least 132.9 mm

3.3 Installment of the Cylinder Head

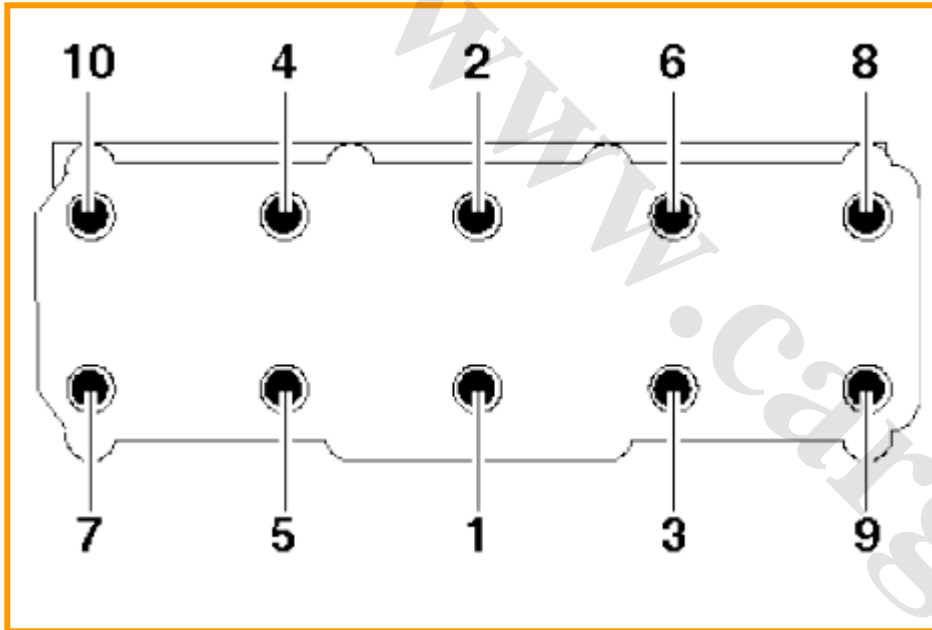

Tighten the cylinder head bolt in the order of the following picture shown:

Steps of the way of tightening

1 – Tighten the bolts to 40 Nm with wrench.

2 – Continue with a fixed wrench rotated 90° (1/4 turn).

3 – Continue with a fixed wrench rotated 90° (1/4 turn).

tips

- ◆ Oil or coolant is not allowed to appear in the blank holes of the cylinder head bolts
- ◆ New cylinder head seals should not be taken directly until being installed.
- ◆ Be careful in dealing with new seals. Leakage will be lead by damage.
- ◆ Displace the cylinder head bolts.

3.4 Structure of the Camshaft

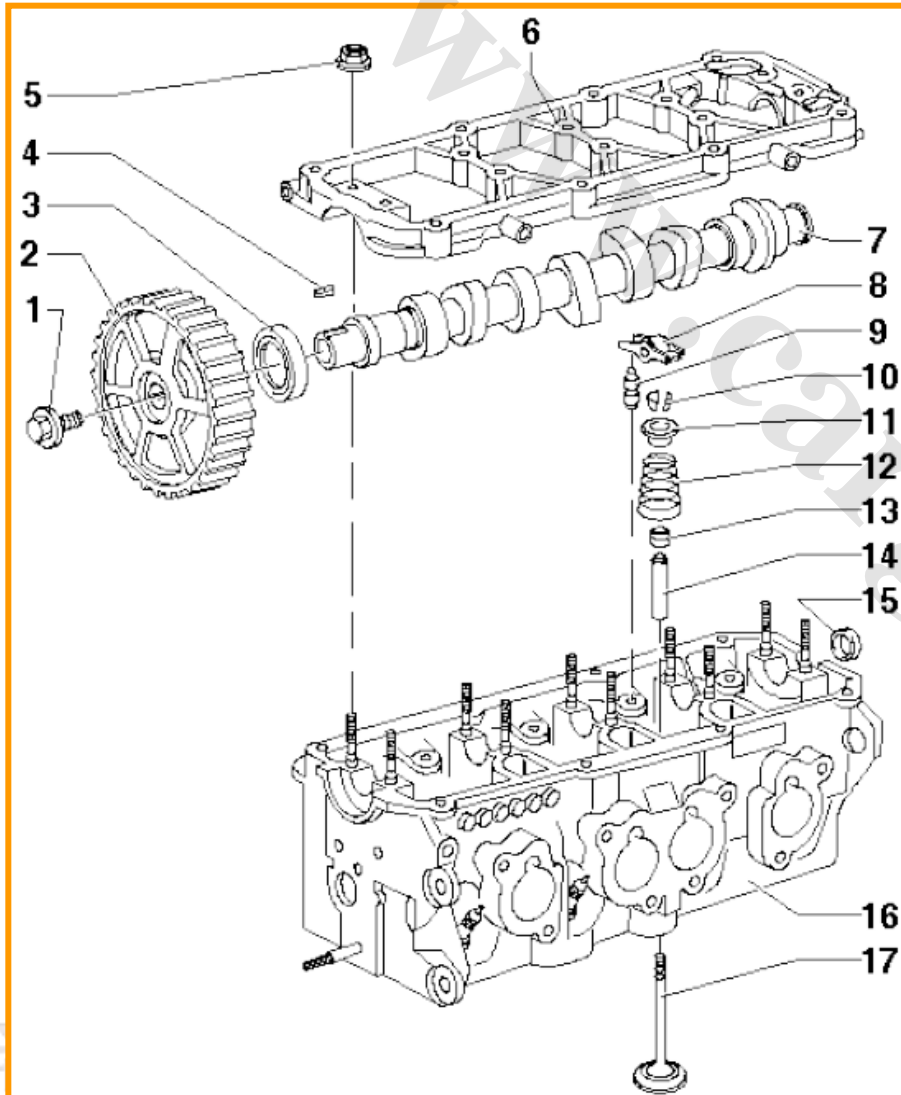

- 1 - 100 Nm
- 2 - Timing gear of the camshaft
- 3 - Sealing ring
- 4 - Flat key
- 5 - 23 Nm
- 6 - Integral bearing cap
- 7 - Camshaft
- 8 - Rocker arm with roller
- 9 - Supporting elements
- 10 - Valve lock split
- 11 - Valve spring seat
- 12 - Valve spring
- 13 - Valve stem seal
- 14 - Valve guide
- 15 - End cap
- 16 - Cylinder head
- 17 - Valve

3.5 Inspection of the valve and the valve guide

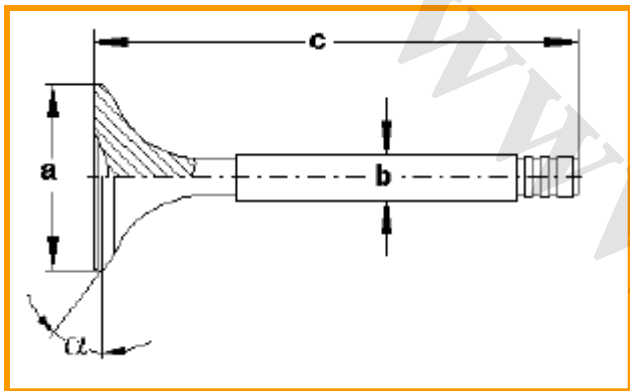

The valve is not allowed to be trimmed, but grinded.

Dimension		Intake valve	Exhaust valve
$\varnothing a$	mm	$39,50 \pm 0,15$	$32,90 \pm 0,15$
$\varnothing b$	mm	$5,980 \pm 0,007$	$5,965 \pm 0,007$
c	mm	93,85	93,85
α	$^{\circ}$	45	45

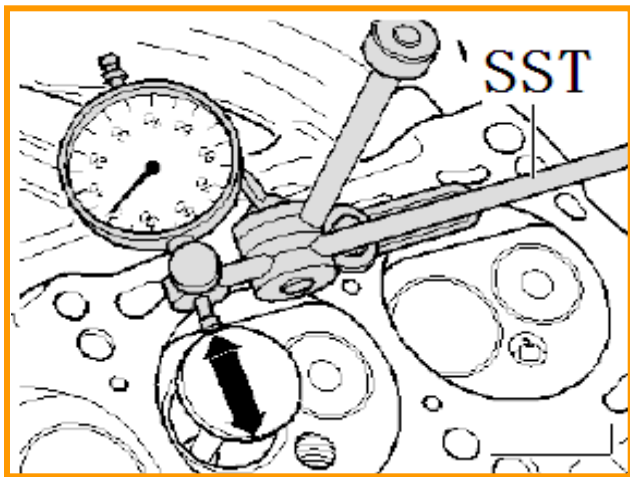

- Insert the new valve into the valve guide. The end of the valve stem should cling to the valve guide. Intake valve can be only used in the intake valve guide, and exhaust valve can be only used in the exhaust valve guide as the diameter of the stems are different.
- Determine swinging gap.
Wear limit: 0.6 mm
If it exceeds swinging gap:
- Replace the cylinder head.

4. Cylinder Block of the Engine

4.1 Cylinder Block BWH

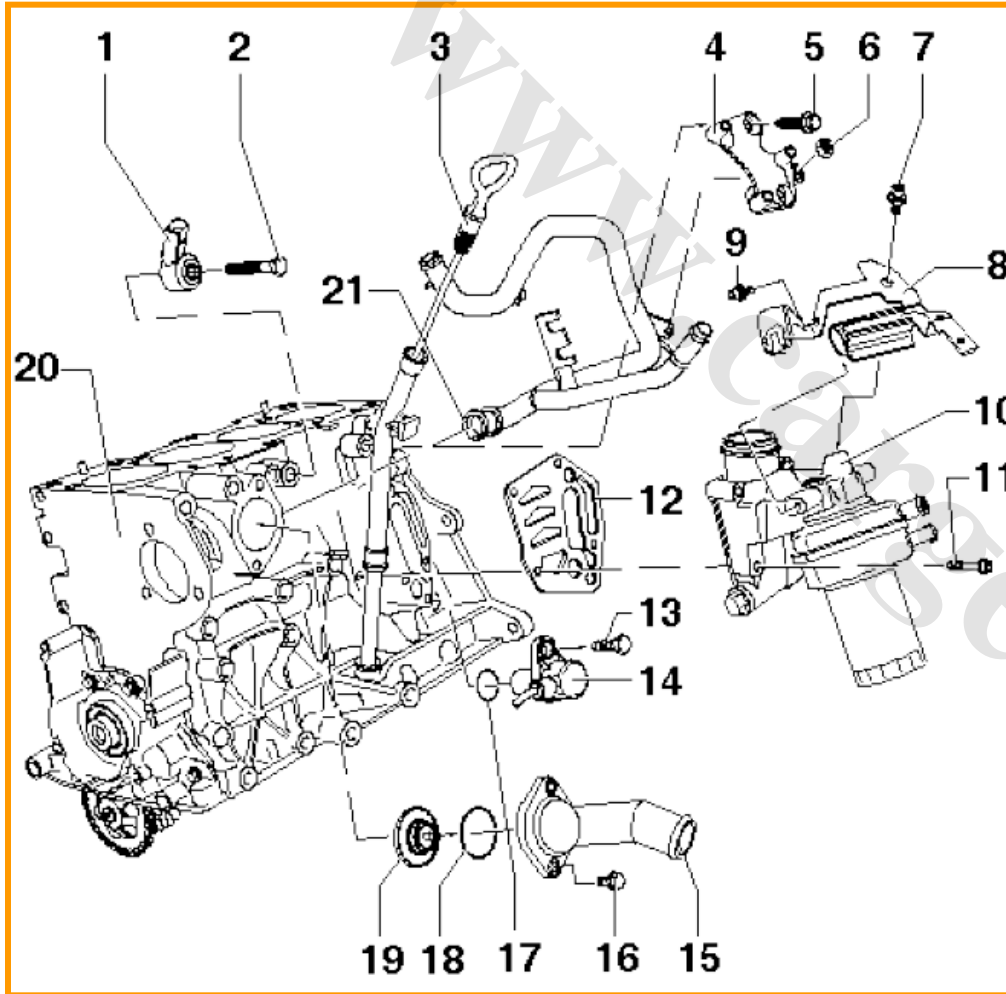

- 1 - Knock sensor
- 2 - 20 Nm
- 3 - Oil Dipstick
- 4 - Support
- 5 - 10 Nm
- 6 - 10 Nm
- 7 - 10 Nm
- 8 - Support
- 9 - 6 Nm
- 10 - Oil filter support with bolt-on kit
- 11 - 15 Nm +90°
- 12 - Seal
- 13 - 10 Nm
- 14 - Speed sensor of the engine
- 15 - Connector
- 16 - 15 Nm
- 17 - O-ring
- 18 - Sealing ring
- 19 - Thermostat
- 20 - Cylinder block
- 21 - Sealing ring for coolant tube

4.2 Cylinder Block BWH

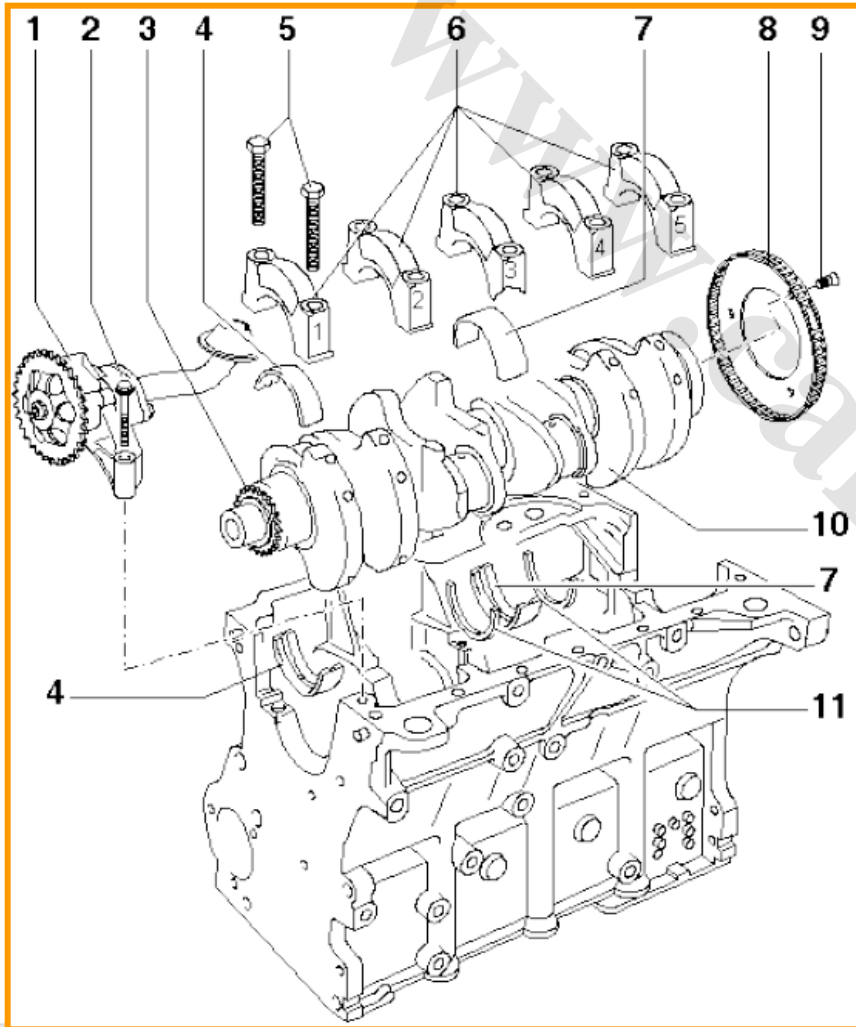

- 1 - Oil pump
- 2 - 15 Nm
- 3 - Chain wheel
- 4 - Bearing bush1&2&3&4&5
- 5 - 40 Nm +90° (1/4 turn) continue to rotate
tighten with the torsion of 40 Nm
- 6 - Bearing cap
- 7 - Bearing bush3
- 8 - Speed sensor for the engine of
Pulse signal wheel
- 9 - 10 Nm +90° (1/4 turn) continue to rotate
- 10 - Crankshaft
- 11 - Thrust washers

4.3 Mark and Size of the Upper Crankshaft Bearing

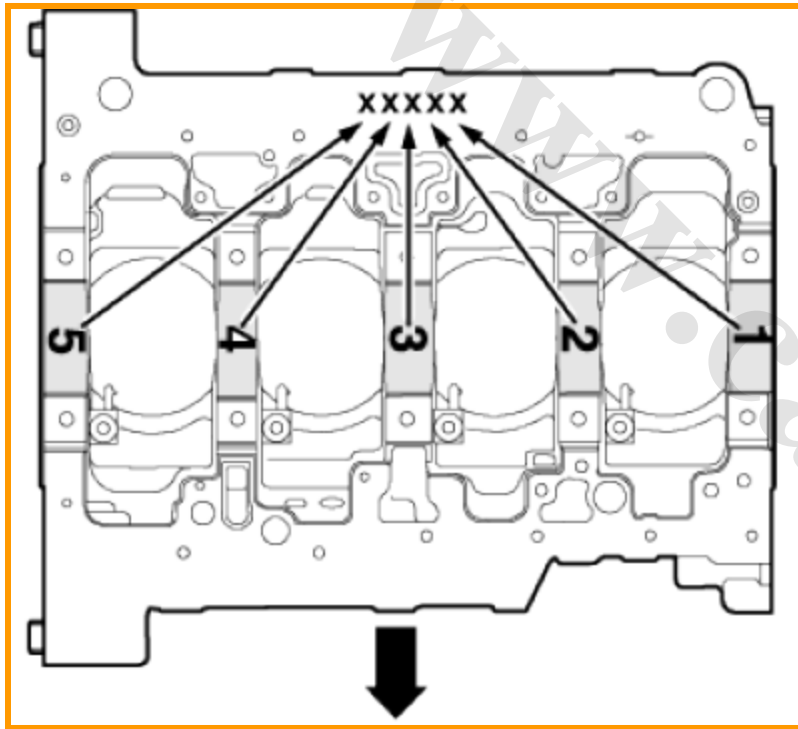

R = Red
 G = Yellow
 B = Blue
 W = White

Label on the bottom sealing surface with letters about how thick the bearing should be installed and the installment location.

Top bush has been factory- installed in the cylinder block according to the right thickness.

Colorful points are used to record the bush thickness.

Size of the crankshaft

(Dimensions in the unit of mm)

Grinding dimension	Crankshaft bearing journal		Crankshaft bearing journal	
	Basic dimension	-0.017 -0.037	42.00	-0.022 -0.042
Rank I	47.75	-0.017 -0.037	41.75	-0.022 -0.042
Rank II	47.50	-0.017 -0.037	41.50	-0.022 -0.042
Rank III	47.25	-0.017 -0.037	41.25	-0.022 -0.042

4.4 Piston and Connecting Rod

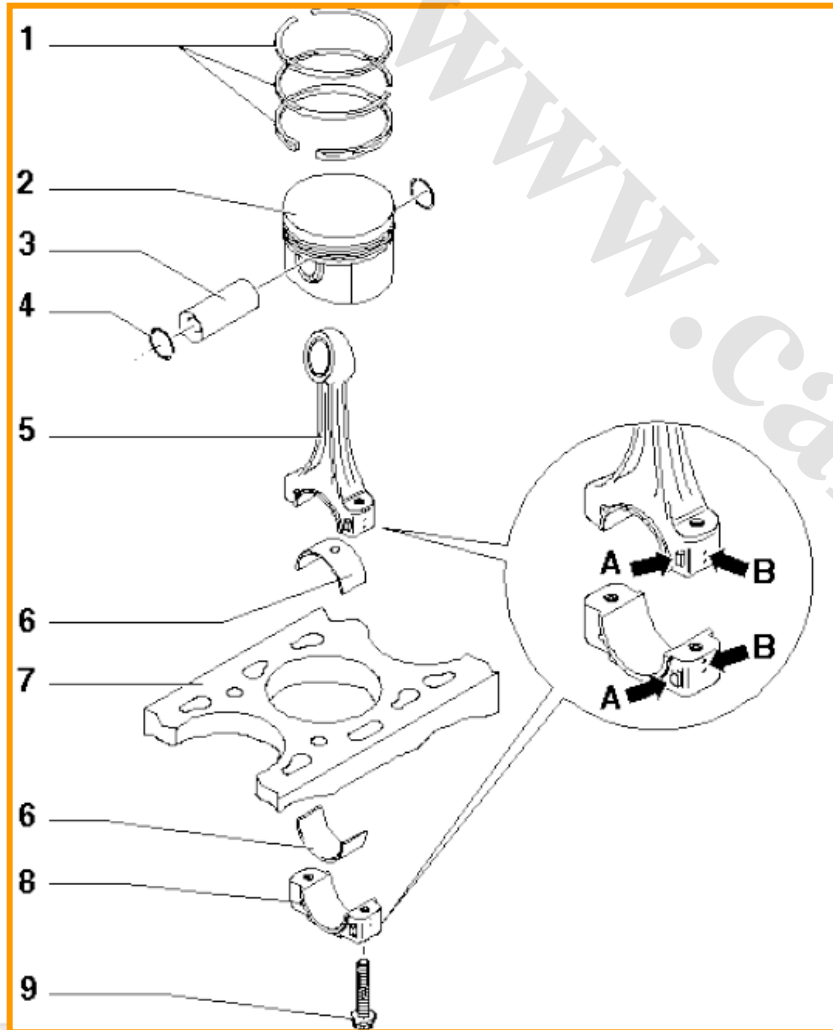

- 1 – Piston ring
- 2 – Piston
- 3 – Piston pin
- 4 – Clasp
- 5 – Connecting rod, disassembled in the method of breaking (fracture) can only be replaced as a set. Mark the cylinder belongs to -B-, Installation location: mark -A- Point to the pulley side
- 6 – Bush
- 7 – Cylinder block
- 8 – Connecting rod cap
- 9 – Connecting rod bolt, 30 Nm + 90° (1/4 turn) continue to rotate

4. Cylinder Block of the Engine

4.5 Measurement of Piston & Piston Ring

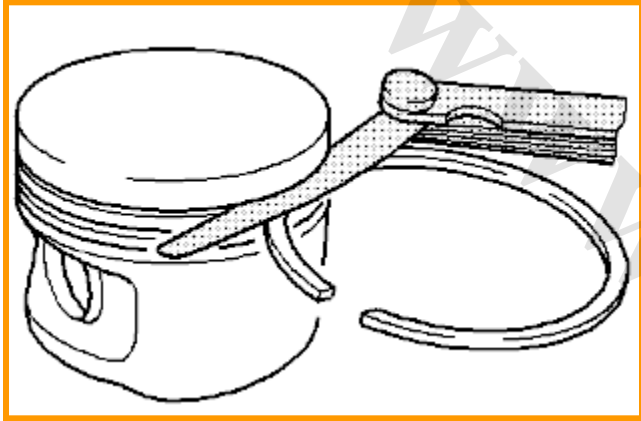

Piston ring		Interval of height	
		New	Wear limit
Compression ring	mm	0,06...0,09	0,20
Slinger	mm	0,03...0,06	0.15

Measure the position 10mm under the lower edge, staggering 90° with the axis of the piston pin.

Relative deviation to the nominal size: maximum 0.04 mm

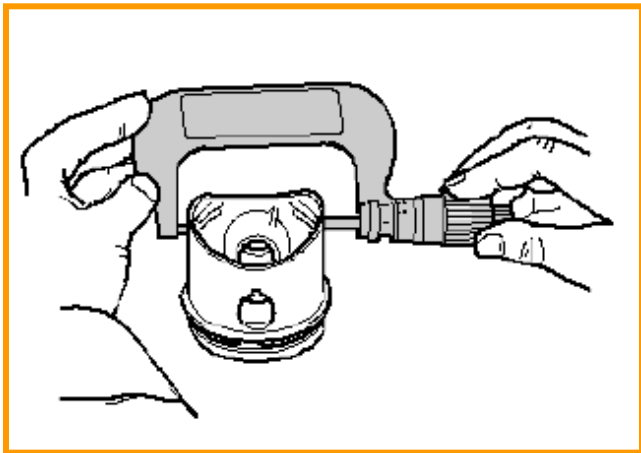

Dimension of piston & cylinder

Grinding dimension		Piston	Cylinder bore
Basic dimension	mm	80,965 ³⁾	81.01

Dimension without graphite layer (thickness of 0.02mm). Graphite layer has been worn.

4.6 Cylinder Bore

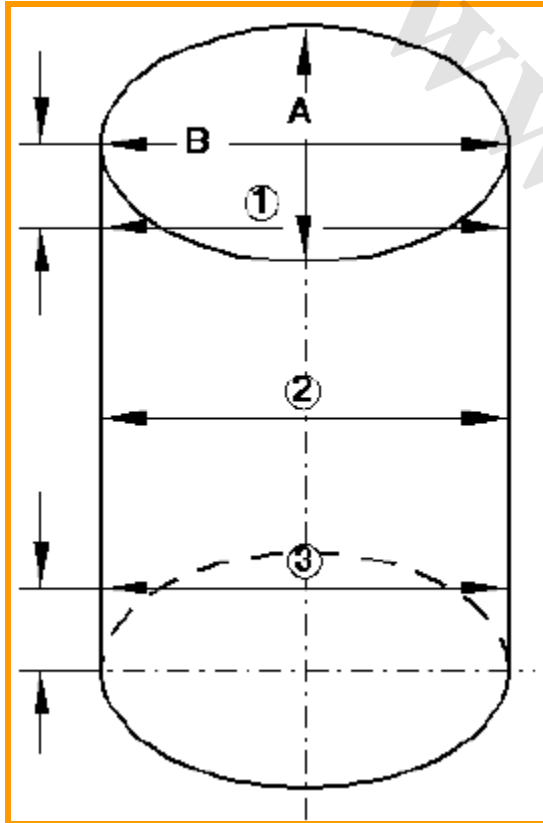

Measure the cylinder bore on the Location 3 in the cross-way along the transverse-A-and vertical-B-.

Relative deviation to the nominal size: maximum 0.08 mm.

Dimension of piston & cylinder

Grinding dimension		Piston	Cylinder bore
Basic dimension	mm	80,965 ³⁾	81.01

Dimension without graphite layer(thickness of 0.02mm).Graphite layer has been worn.

5. Lubricating System of the Engine

5.1 Lubricating System BWH

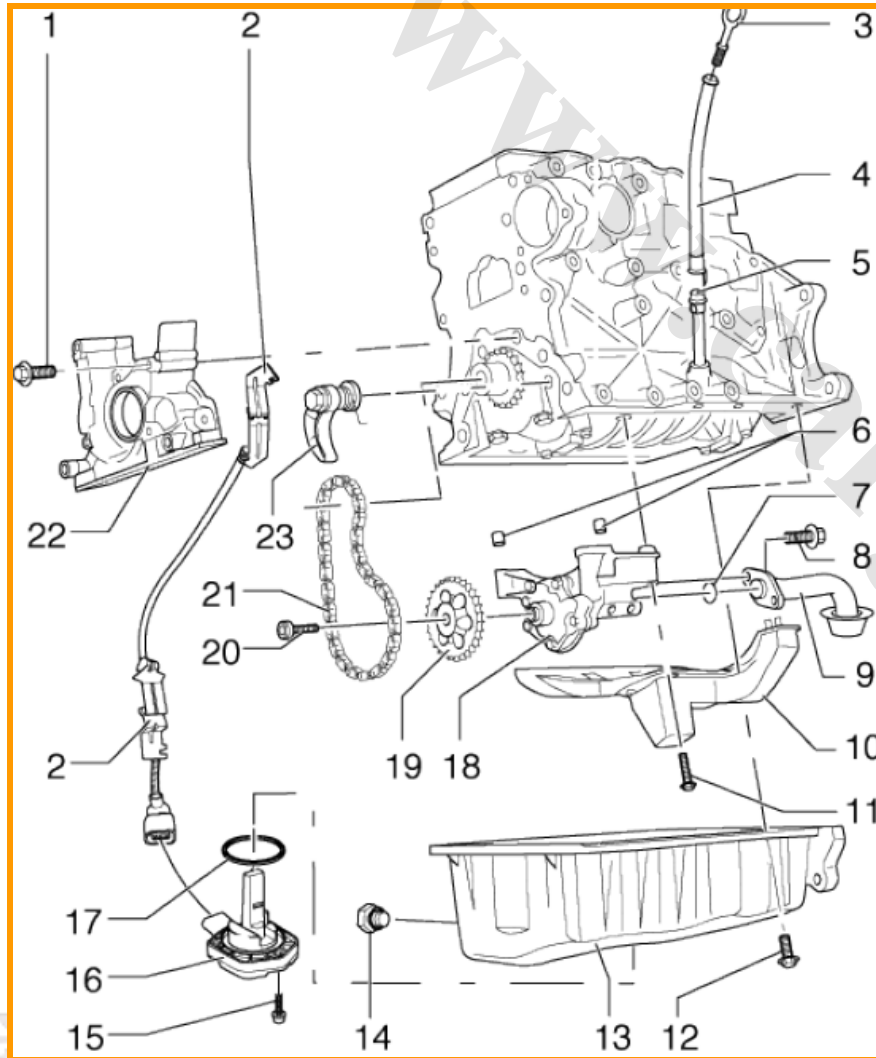

- 1 - 15 Nm
- 2 - support
- 3 - Oil Dipstick
- 4 - Guide thimble
- 5 - Guide pipe
- 6 - Fitting set
- 7 - O-ring
- 8 - 15 Nm
- 9 - Oil intake tube
- 10 - Oil baffle
- 11 - 15 Nm
- 12 - 15 Nm
- 13 - Oil sump
- 14 - Oil drain plug , 30 Nm
- 15 - 10 Nm
- 16 - Oil level and oil temperature sensor
- 17 - Sealing ring
- 18 - Oil pump
- 19 - Chain wheel
- 20 - 20 Nm +90° (1/4 turn) continue to rotate
- 21 - Chain
- 22 - Sealing flange
- 23 - Chain tensioners and tensioning rail

5.2 Oil Filter Support

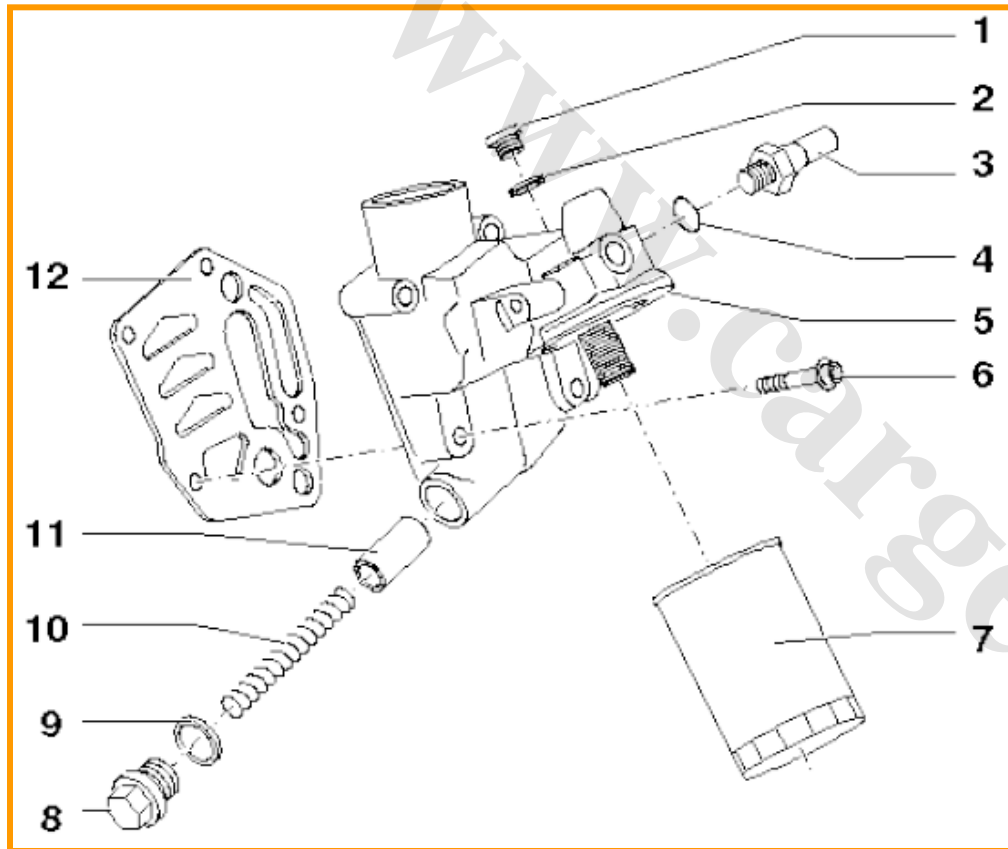

- 1 - Screw plug, 15 Nm
- 2 - Sealing ring
- 3 - 1.4 bar Oil pressure switch-F1- ,
- 4 - Sealing ring
- 5 - Oil filter support
- 6 - 15 Nm +90° (1/4 turn) continue to rotate
- 7 - Oil filter
- 8 - Screw plug , 40 Nm
- 9 - Sealing ring
- 10 - Spring
- 11 - Piston
- 12 - Sealing strip

6. Cooling System of the Engine

6.1 Components of Cooling System BWH

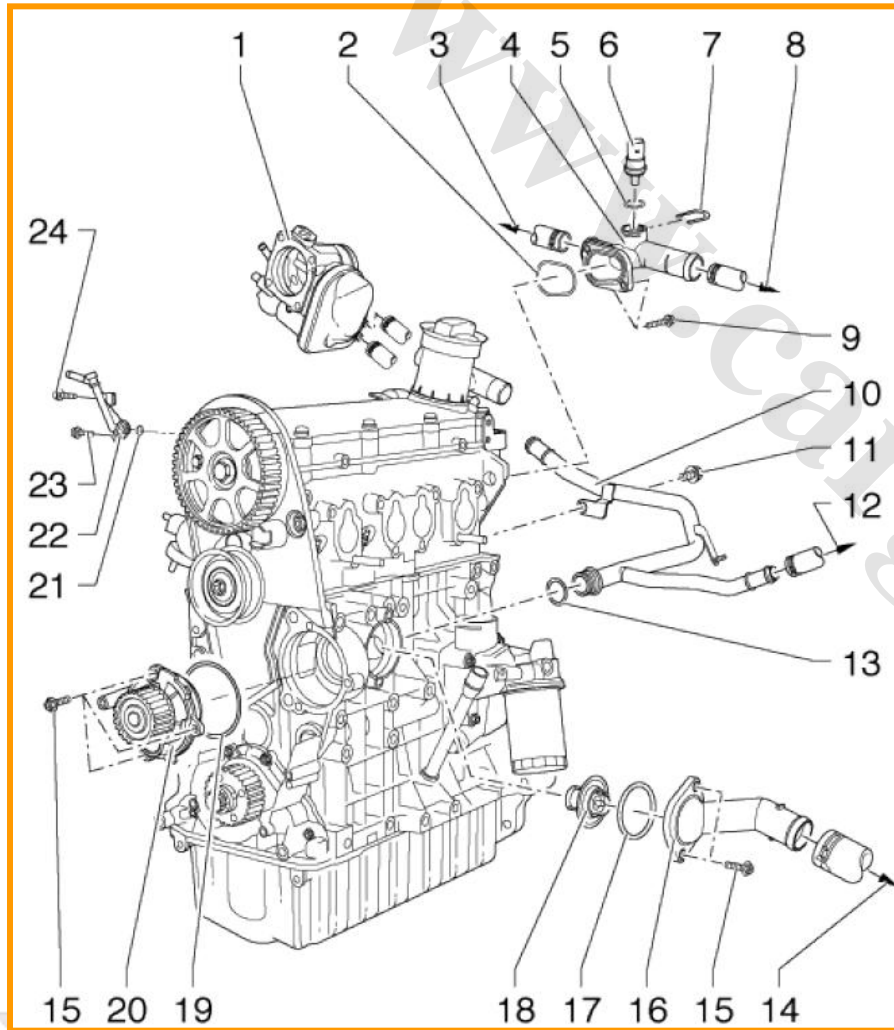

- 1 - Throttle control unit
- 2 - Sealing ring
- 3 - Heat exchanger for the heater device
- 4 - Cooling fluid dispenser shell
- 5 - O-ring
- 6 - Coolant Temperature Sensor
- 7 - Clip
- 8 - To upper radiator
- 9 - 10 Nm
- 10 - Cooling fluid tube line
- 11 - 40 Nm
- 12 - To the hose of compensation tank
- 13 - To the hose on the lower part of the radiator
- 14 - To the hose on the lower part of the radiator
- 15 - 15 Nm
- 16 - Joint fitting
- 17 - O-ring
- 18 - Thermostat
- 19 - Coolant pump
- 20 - Coolant pump
- 21 - Exhaust piping
- 22 - Exhaust piping
- 23 - Exhaust piping
- 24 - Throttle control unit

6.2 Coolant Hose Connection Diagram

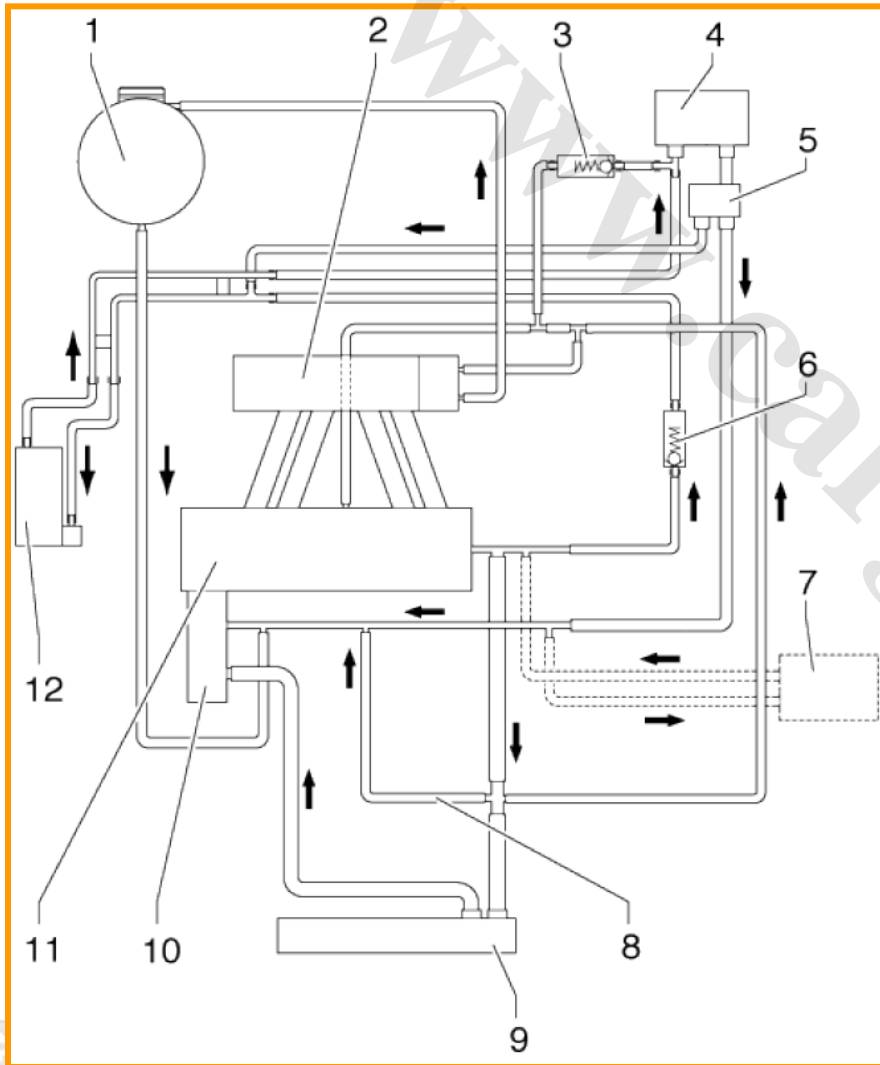

- 1 - Compensation tank
- 2 - Intake manifold with heating throttle casing pipe
- 3 - Heat exchanger with heater
- 4 - Oil cooler of the transmission
- 5 - Coolant hose
- 6 - Radiator
- 7 - Coolant pump and thermostat
- 8 - Cylinder head / Cylinder block

www.cargeek.ir
Thank you!

奔腾 BESTURN

Technical Training of BESTURN B50

Intake & Exhaust Control System

奔腾 BESTURN

Suitable Post: CTO

Internal data, please do not disclose it externally

Curriculum Goals

- Familiar with the Basic Structure of Intake System
- Grasp the New Technique of Intake System
- Grasp the Overhaul Method of Intake System
- Familiar with the Control Principle of Exhaust Emission & Overhaul

Contents

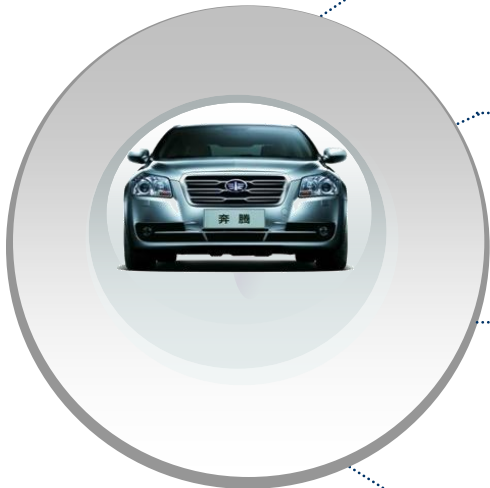

1. Basic Structure of Intake System

2. Variable Intake Control

3. Secondary Air Injection System

4. Discharge System Control

1.1 The Structure Diagram of Intake System [BWH]

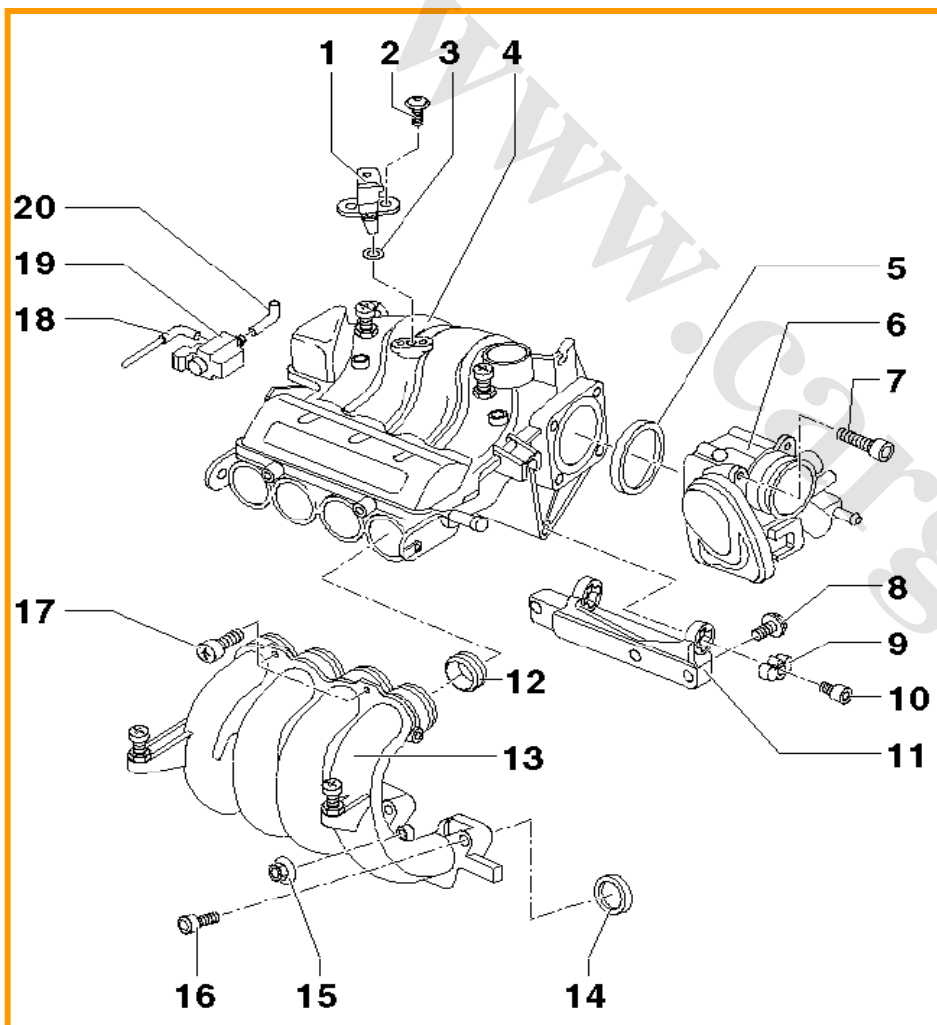

- 1 - Oil-taking Pressure Sensor - intake temperature sensor
- 2 - 3 Nm
- 3 - O-ring
- 4 - The Parts up the Air Inlet Pipe (with Intake Manifold Conversion)
- 5 - Seal Ring
- 6 - Throttle Control Unit
- 7 - 8 Nm
- 8 - 15 Nm
- 9 - Rubber Support
- 10 - 8 Nm
- 11 - Studdle
- 12 - Seal Ring
- 13 - The Parts under the Air Inlet Pipe
- 14 - Seal Ring
- 15 - 25 Nm
- 16 - 25 Nm
- 17 - 3 Nm
- 18 - Vacuum Hose to the Overvoltage Adjustment Element
- 19 - Intake Manifold Switch Valve
- 20 - Vacuum Hose to the Overpressure Storage Container in the Air Inlet Pipe

2.1 B50 Intake Stroke / Cross Sectional Area Variable Control [BWH]

ECU, according to the engine rotate speed, changes the intake stroke by changing the position of the plate-turnover.

Rotate Speed is lower than 4000rpm-long distance

Rotate Speed is higher than 4000rpm-short distance

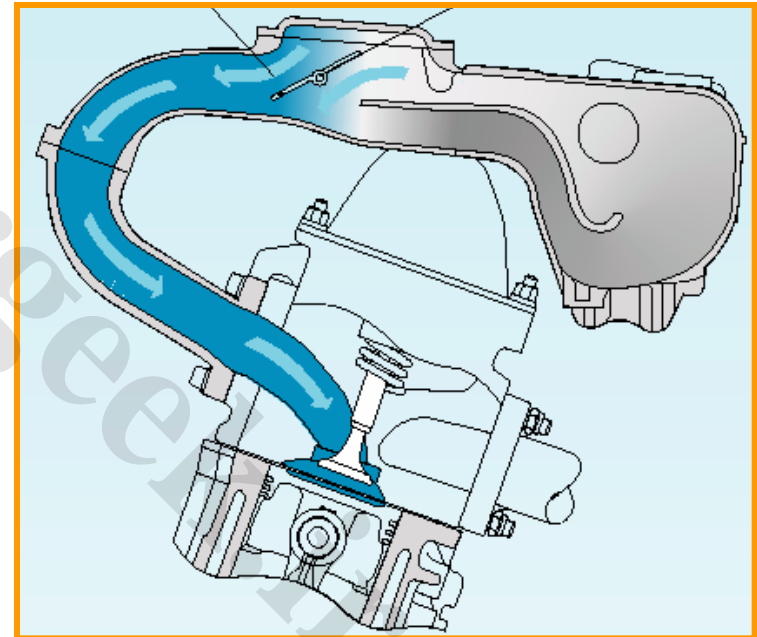
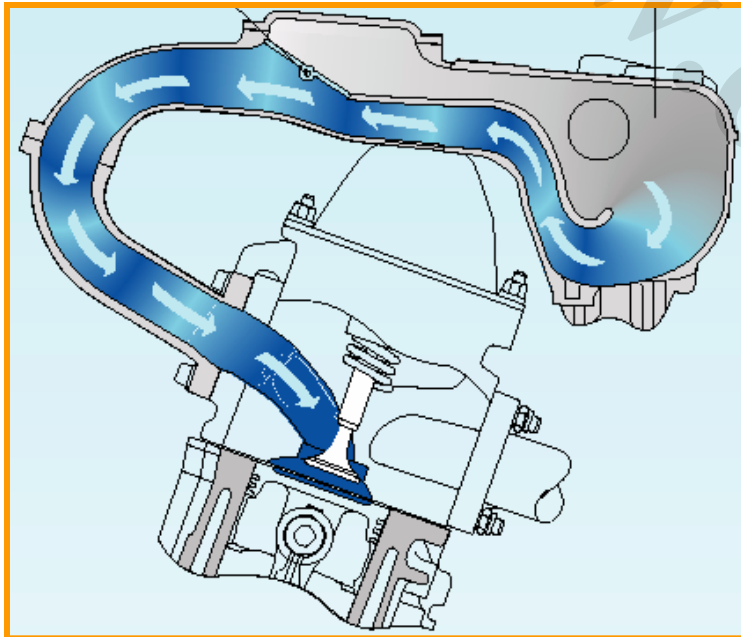

2.2 The Operating Principle of Air Inlet Pipe Adjustment:

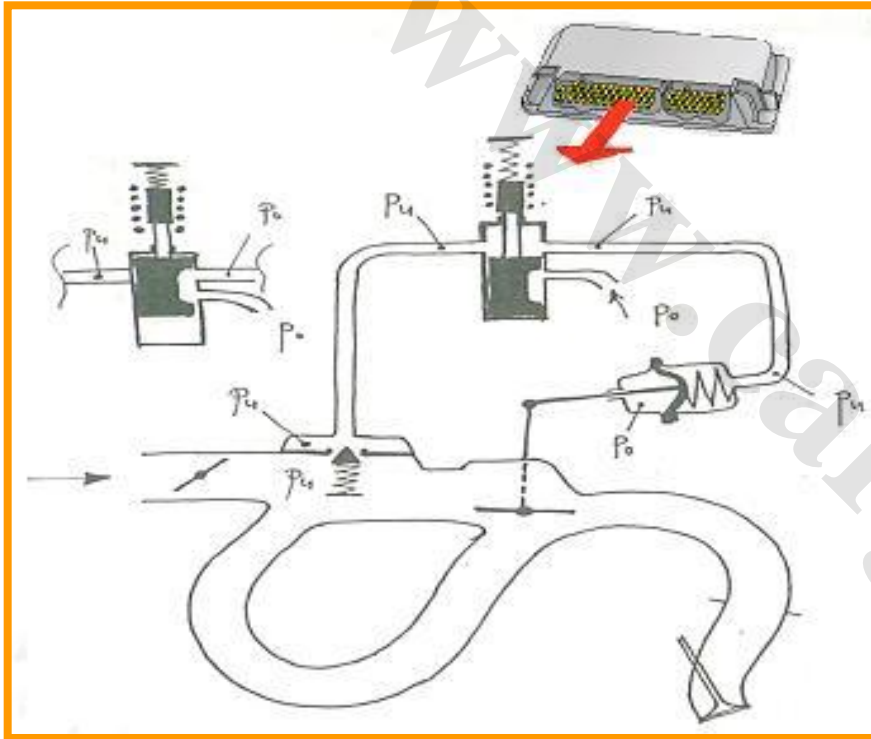

- When the rotate speed of the engine is lower than 4000r/min (for example), the active valve of the variable intake manifold will be closed. Air enters into the cylinder through a longer path and the inlet flow in the tube has a large inertia, playing the role of the inertia supercharger to obtain a larger torque;
- When the engine speed exceeds 4000r/min, the ECU, according to the load, temperature and other signals to ground the solenoid valve, to open the solenoid valve, and force the diaphragm to move to the right, ensuring it sufficient to drive the valve rotation by the connecting rod. At that time the air flows through the shorter trajectory into the cylinder to reduce the resistance of the delaying, so that the engine can get higher power when speeding.

3. Secondary Air Injection System

3.1 The Structure of B50 Secondary Air Injection System [BWH]

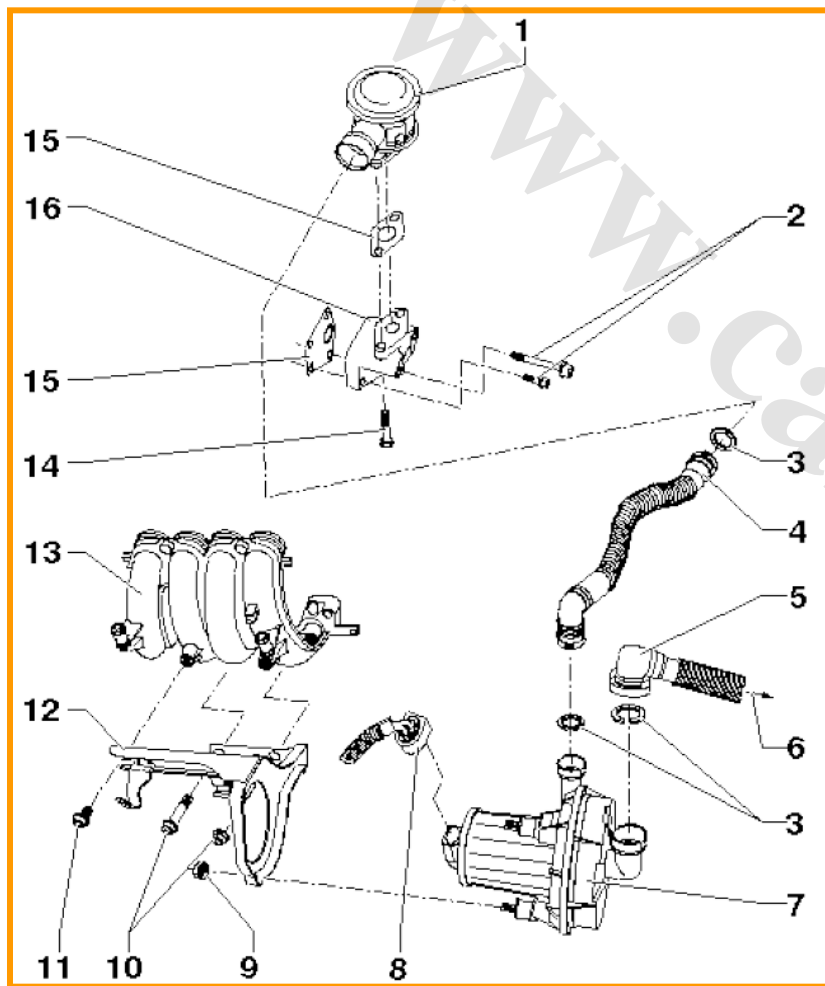

1 - Combination Valve

2 - 10 Nm

3 - O-Ring

4 - Pressure Hose

5 - Intake Hose

6 - Air Filter

7 - Secondary Air Pump Motor

8 - Connecting Plug

9 - 10 Nm

10 - 25 Nm

11 - 8 Nm

12 - Holder

13 - The Parts under the Air Inlet Pipe

14 - 10 Nm

15 - Sealing Strips

16 - Joint Fitting \for Combination Valves

3.2 The Operating Principle B50 Secondary Air Injection System [BWH]

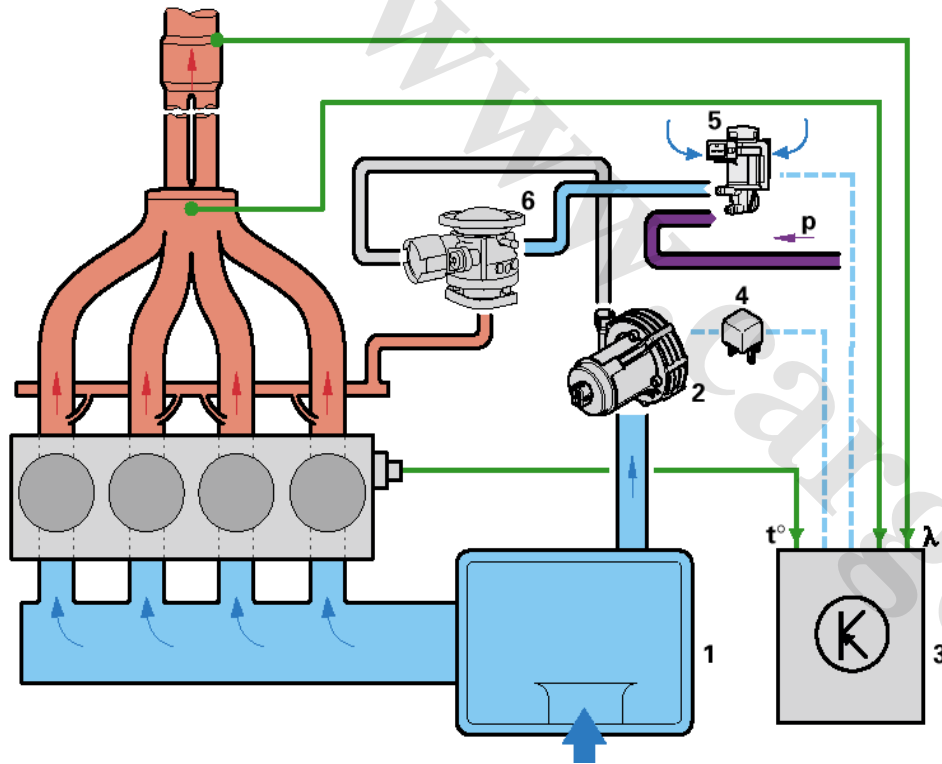

- Secondary Air Injection System is one of the outside purification device to reduce the exhaust emission.
- It blows extra air (secondary air) into the exhaust gas to increase the oxygen content, enabling the unburned harmful substances: carbon monoxide (CO) and hydrocarbon(HC) to burn again in the high temperature environment.

1. air filter
2. Secondary air pump
3. Engine control module
4. Secondary air relay
5. Secondary air control valve
6. Secondary air combination valves

3. Secondary Air Injection System

Continued

- The engine computer activates the secondary air system to work. The engine computer controls the secondary air inlet valve and drive the combination valves to work under pressure P. After starting the engine, the air going through the air filter is directly blown into the exhaust valve by the secondary air pump, whose power is get from the relay. The secondary air pump's function is to press the air into the exhaust gas behind the exhaust valve in a very short time. When it does not work, the hot exhaust gas will stay at the outside combination valve, but not enter the secondary air pump.
- In the control process, the self-diagnostic system is testing at the same time . Due to the increasing oxygen content in the exhaust gas, the oxygen sensor voltage is reduced, so the oxygen sensor must be in the working condition. When the secondary air system works normally, the oxygen sensor will detect a very dilute gas mixture.

Status	Coolant Temperature	Operation Hours
After the Cold start	+ 5 °C ~33 °C	100 seconds
Idle Speed after the Hot Start	Until the Maximum 96 °C	10 seconds

3.3 B50 Secondary Air Injection System Combination Valves [BWH]

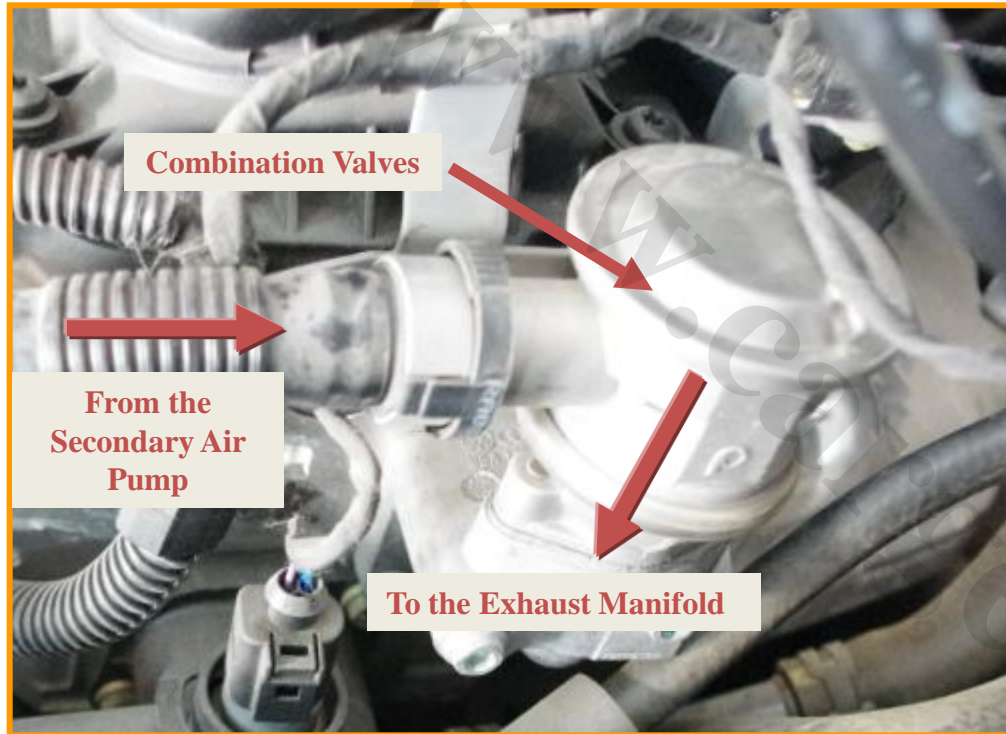

- The system starts to work a period after the engine cold or hot starting.
- Working Time: 100 seconds or 10 seconds
- Function- To make the unburned CO and HC to burn again; The catalytic converter reaches its operating temperature quickly.
- We can see if the system is working (high oxygen content) from the oxygen sensor data analysis with the use of diagnostic equipment.

4.1 Fuel Evaporative Emissions (EVAP) Control System Chart

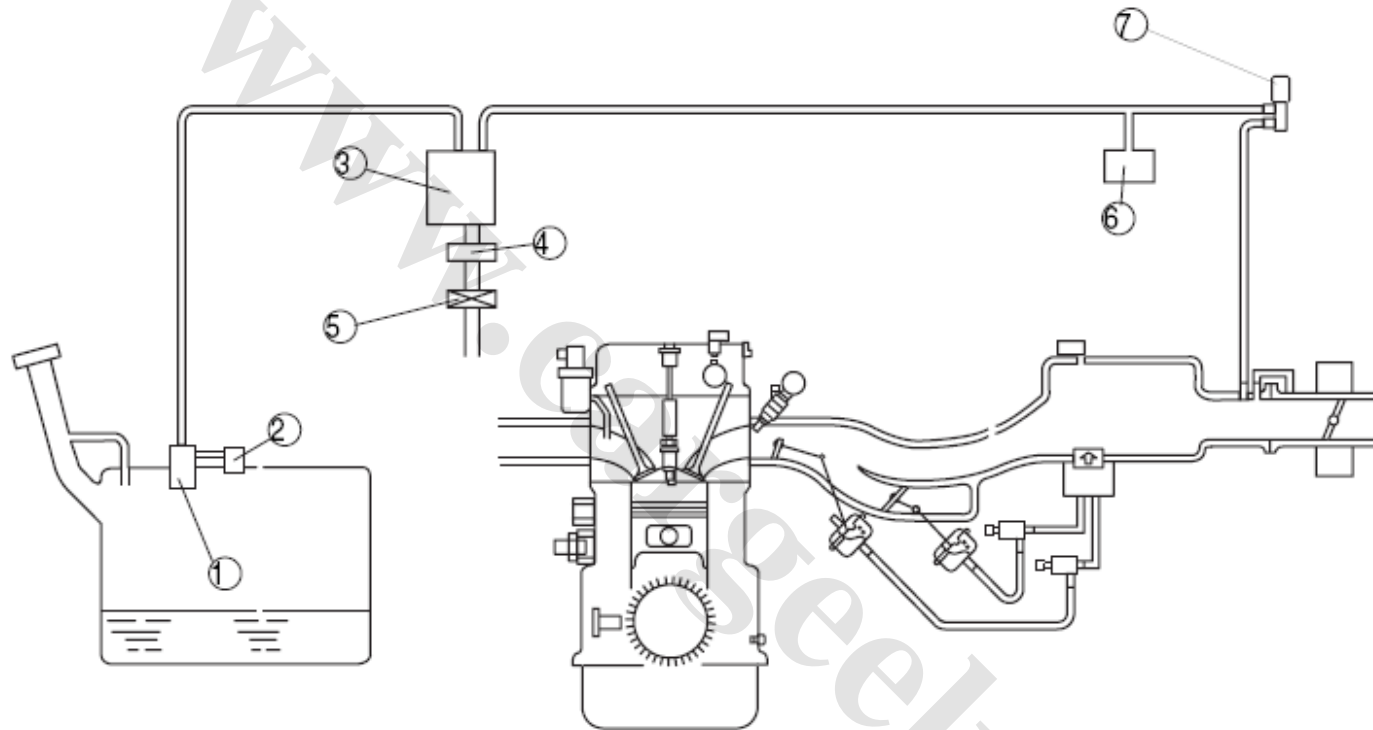

1. Fuel Oil Closing Valve

2. Rollover Valve

3. Charcoal Canister

4. EVAP System Leakage Detection Pump

5. Air Filter

6. Air Collector

7. Purge Solenoid Valve

4.2 Structure /Operation of Carbon Canister Electromagnetic Valve

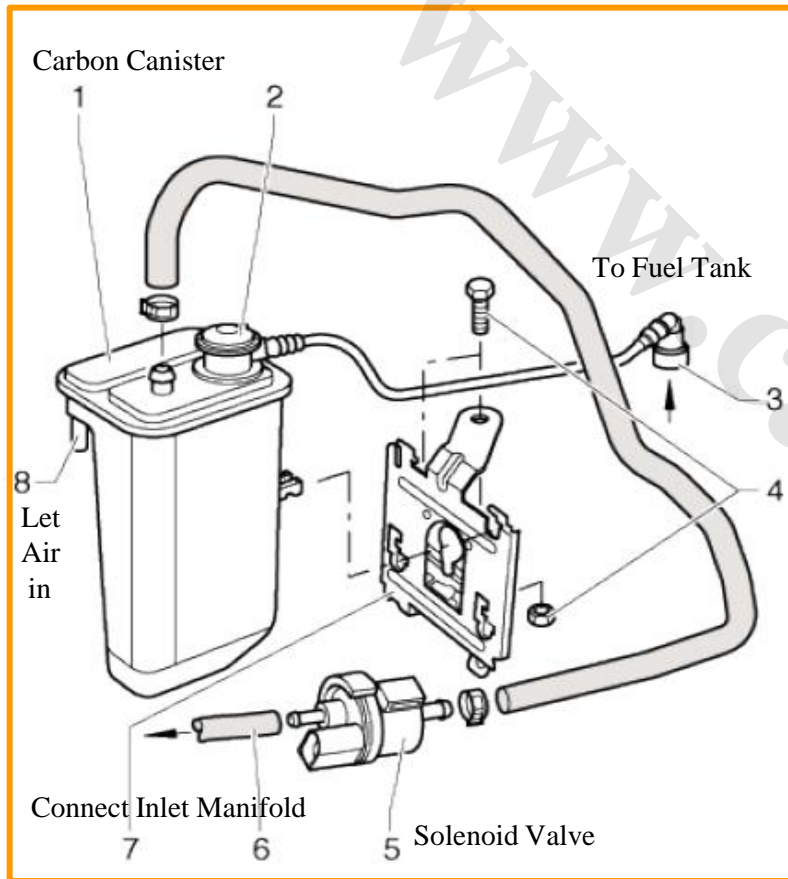

When the engine stops, the pressure will increase, then the vapors in the tank will flow out and be absorbed by the carbon canister.

When the engine is running, the vapors absorbed by the charcoal canister will flow through the solenoid valve together with the imported air from the opening, and will be supplied to the engine according to the operation condition of the engine.

If the pressure in the fuel tank drops, the air will be absorbed by the roll-over safety valve through the carbon canister opening. If the carbon canister opening is blocked, the negative pressure valve at the filler cap is to be opened, then air is introduced to the tank, preventing the vacuum degree in the tank from increasing, thereby increases the fuel tank load.

Signals sent out from PCM energize and magnetize the coil, which then pulls the plunger, which when pulled will enable the path between the valve ports to open. The evaporation gas is thus imported to the intake system according to the vacuum degree in the intake manifold.

4.3 Catalytic Converter System [BWH]

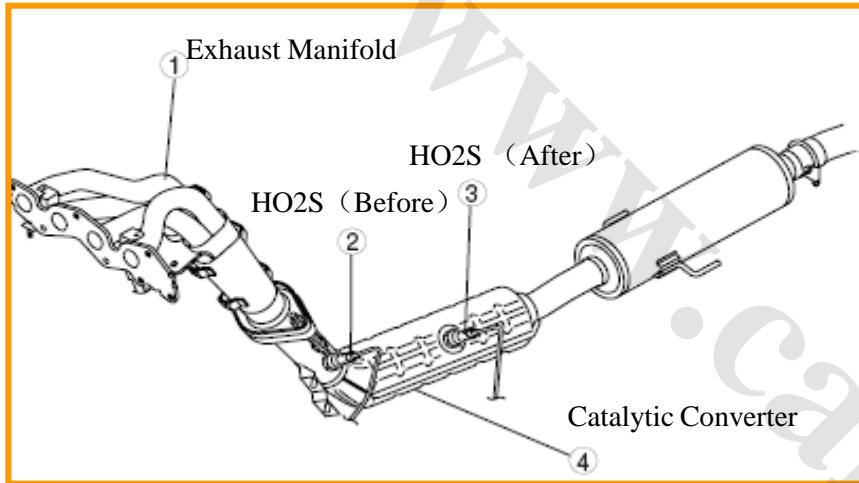

Use the oxidation reduction reactions of the exhaust when getting through the catalytic converter to purify exhaust pollutants (HC, CO, NOX).

- Oxidation process

Harmful HC (hydrocarbon) and CO (carbon monoxide) combine with oxygen to produce harmless carbon dioxide and water.

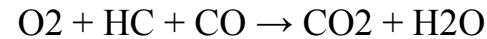

- Reduction process

Harmful NOX (nitrogen oxides) converts into harmless nitrogen and oxygen. Part of the oxygen is generated in this process for the oxidation process.

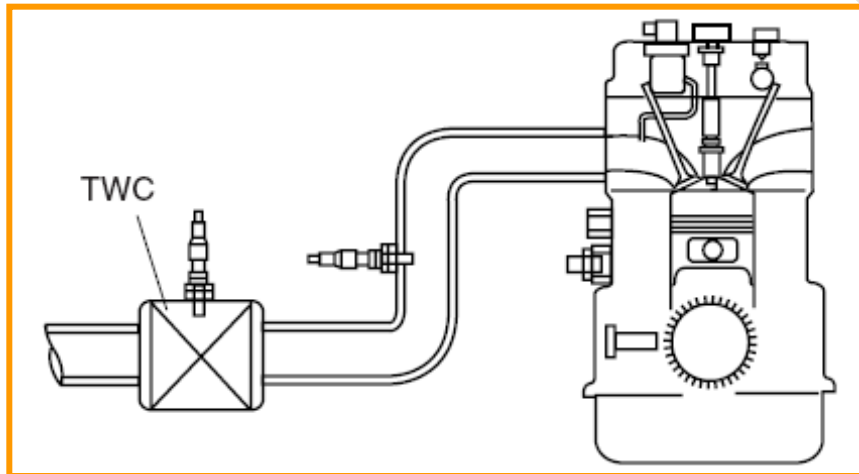

4.4 Basic Principle & Strategy of Engine Control

Converter with Good Capacity of Oxygen Storage (High OSC)

When the converter has enough oxygen storage capacity, the output of the downstream oxygen sensor is almost a straight line.

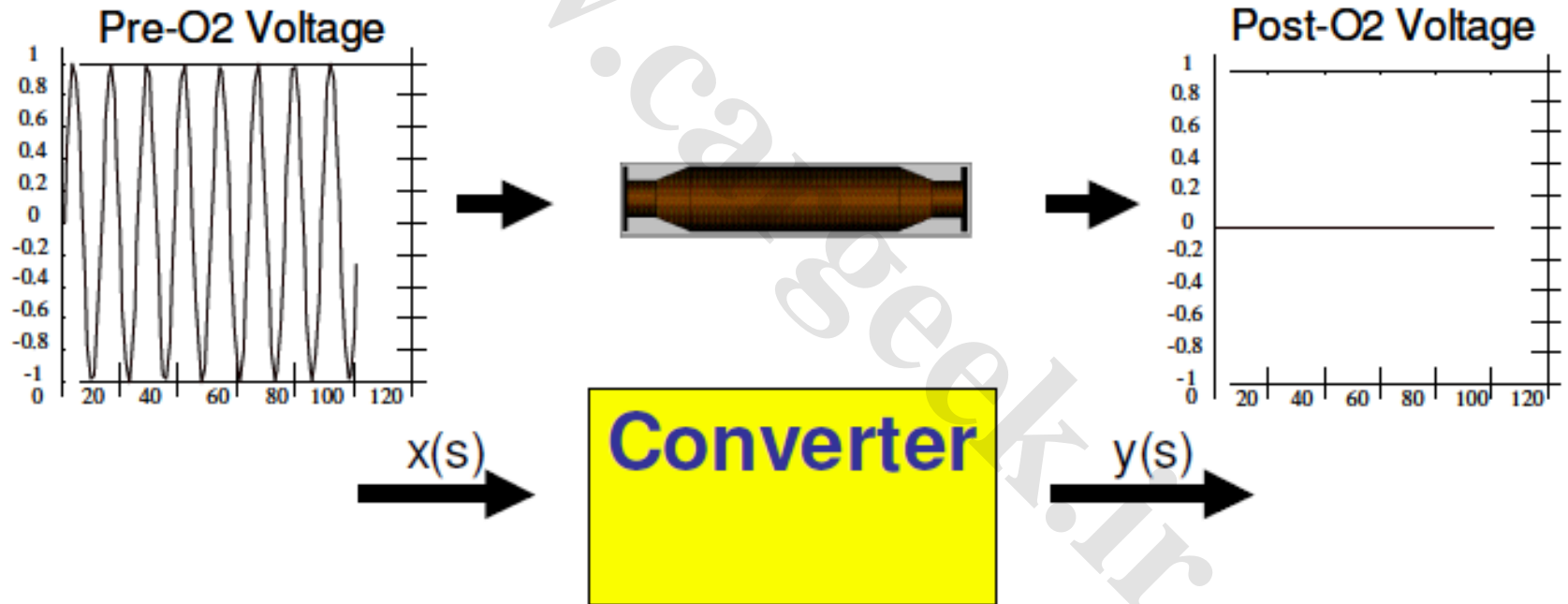

Continued

The converter which has lost its oxygen storage capacity (Low OSC)

When the converter loses its oxygen storage capacity, the output of the downstream oxygen sensor will be similar to the output of the upstream oxygen sensor.

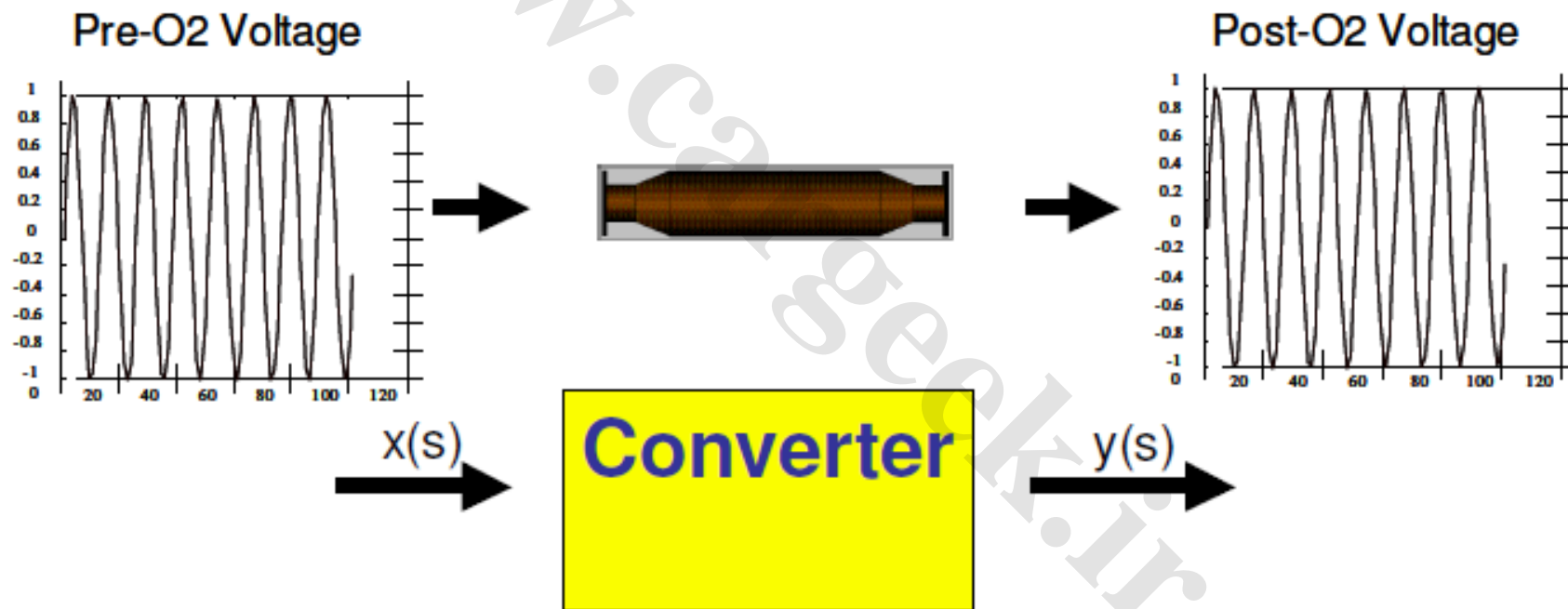

www.cargeek.ir
Thank you!

奔腾 BESTURN

Technical Training of BESTURN B50

Engine Input Sensor Control

奔腾 BESTURN

Suitable post: CTO

Internal data, please do not disclose it externally

Curriculum Goals

- Comprehend the basic principle of the sensor
- Master the measurement inspection methods of the sensor
- Familiar with the data analysis of the diagnostic instrument sensor
- Comprehend the function of the sensor to the PCM



1. Crank Position Sensor (BWH)

2. Camshaft Position Sensor (CMP)

3. Accelerator Pedal Position Sensor

4. Throttle Position Sensor

5. Engine Coolant Temperature (ECT) Sensor

6. Temperature-Manifold Absolute Pressure Sensor

7. Oxygen Sensor (HO2S)

8. Knock Sensor

1.1 Location & Function of Component

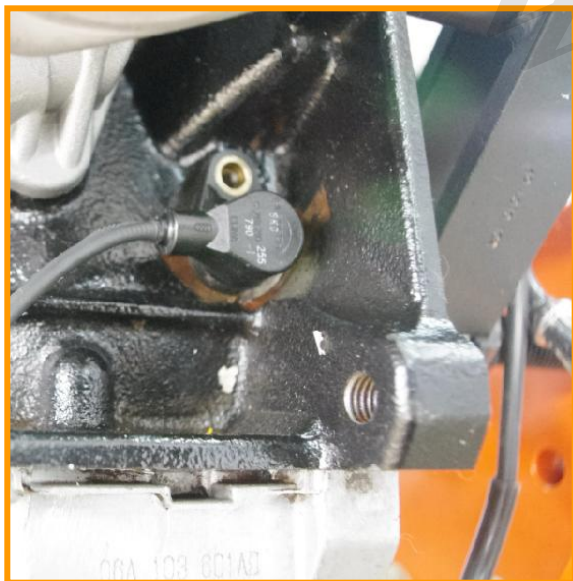

- **Location:** Sensor CKP is installed in the front of the transmission housing, which is aligned with the flywheel cylindrical.
- **Function:** Detect the rotary position and the speed of the engine crankshaft, ECM makes sure of the rotary position and the speed of the crankshaft with the signal.
- **Composition:** Flux sensor mainly consists of signal rotor, sensing coil, permanent magnet and magnetic yoke.

1. Crank Position Sensor (BWH)

1.2 Principles & Detections of Components

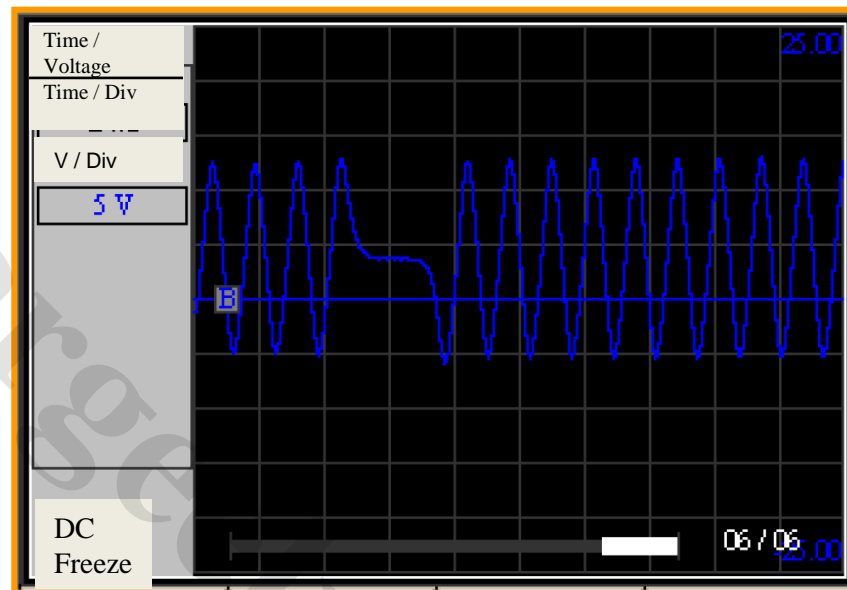
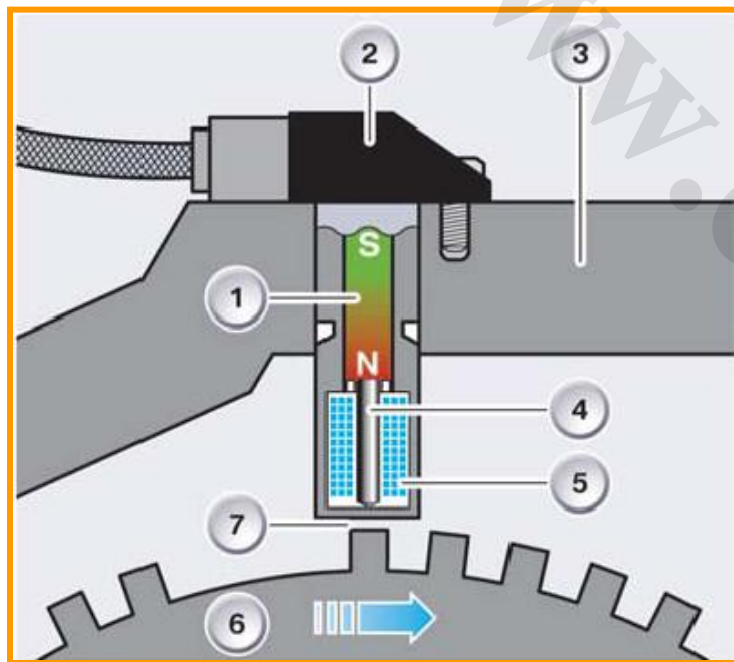

1. Crank Position Sensor (BWH)

1.3 Schematic Circuit of Crank Position Sensor (CKP)

Plug of Crank Position Sensor:

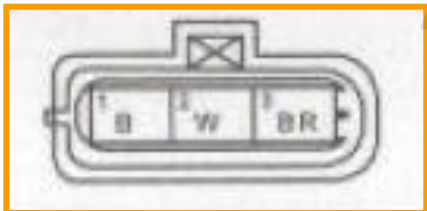

Interval with the ring gear	Coil resistance	Coil inductance
0.3-1.5mm	616- 504Ω	240mH ± 15%

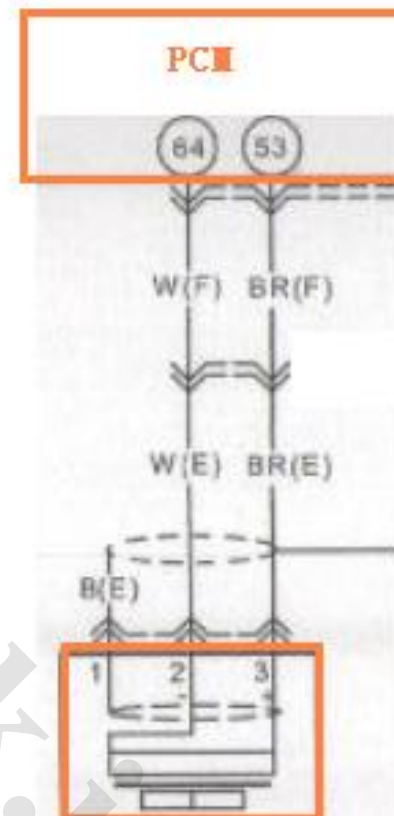

Crank Position Sensor

2.1 Location & Function of Component

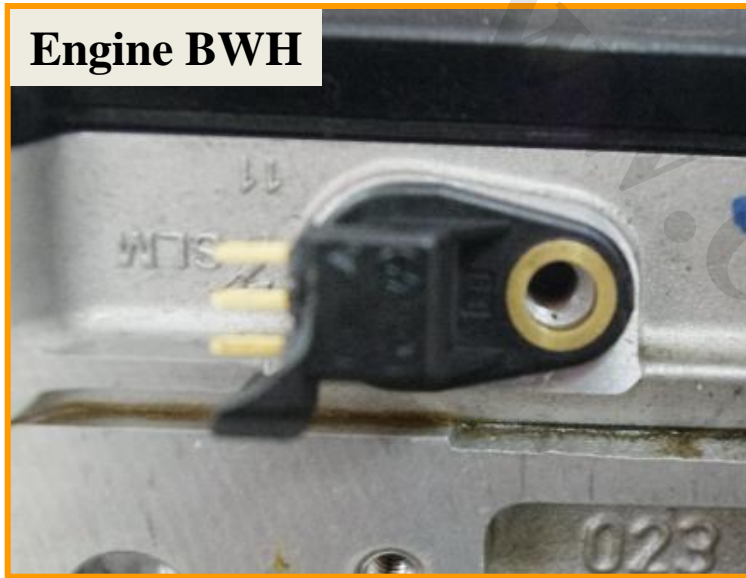

- **Location:** At the back of the valve cover, Signal round is installed at the back of the camshaft, and operate synchronously with it.
- **Function:** Offer the phase information of camshaft to ECM, determine which cycle trip of the engine works in.
- **Performance:**

Operating Voltage	Operating Interval
4. 5-13V	0. 3-2mm

2.2 Component Principle

With the principle of Hall element

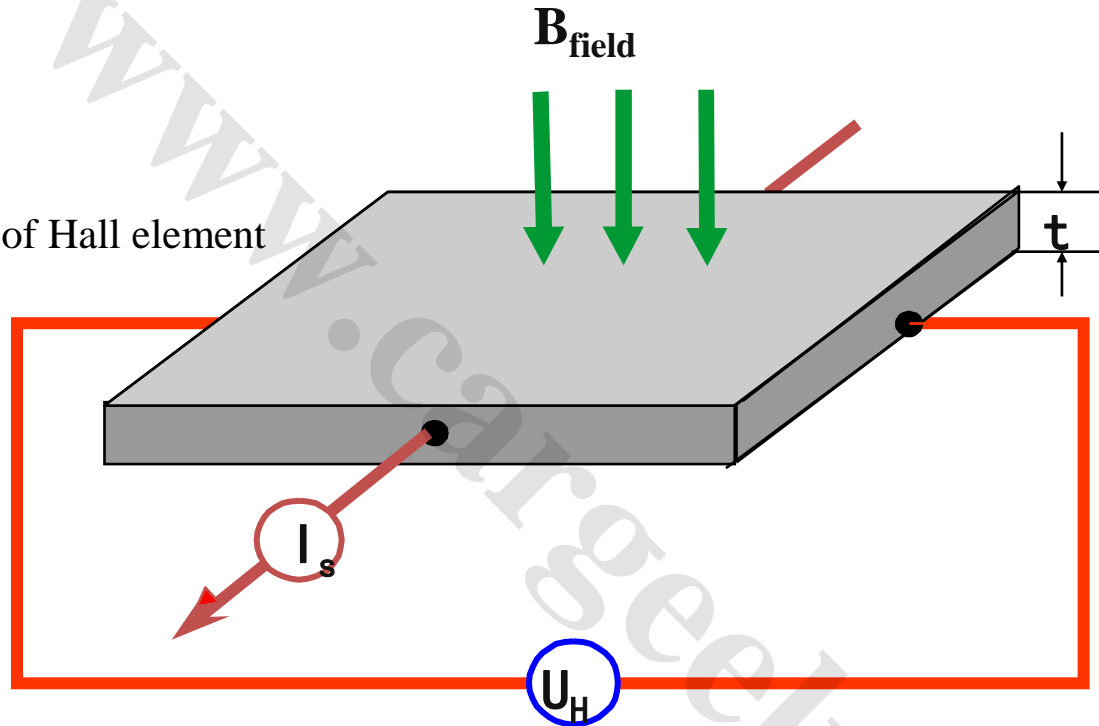

U_H = Hall voltage
 R_H = Hall coefficient
 I_S = Current flowing through the Hall element
 B_{field} = Magnetic field intensity
 T = Thickness of the Hall element

$$U_H = R_H * \frac{I_S * B_{field}}{t}$$

2.3 Component Principle

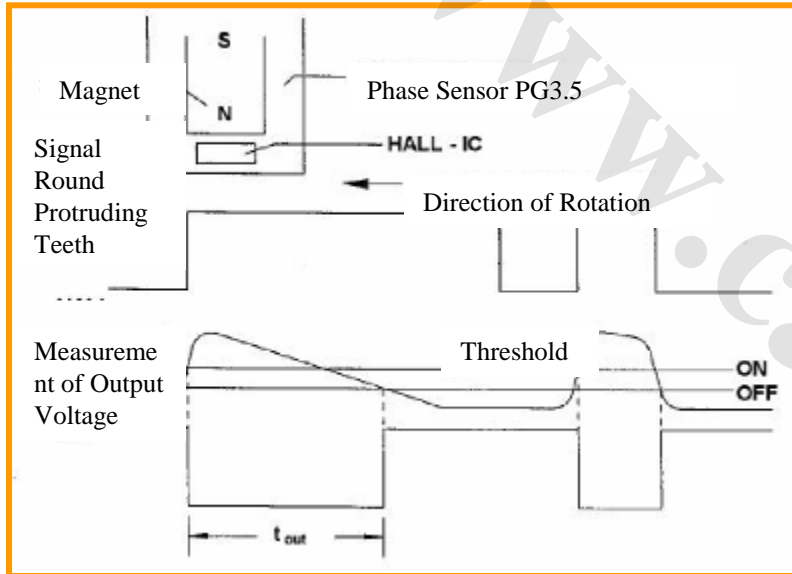

- Principle of the curve shown on the left
- With the Hall principle, IC is located in front of one pole of the Permanent magnet, when signal round is rotated by the camshaft, the strength of the magnetic field lines and the Output voltage signal are varied from the variation of tooth.

2. Camshaft Position Sensor (CMP)

www.CarGeek.ir



2.4 Component Detection

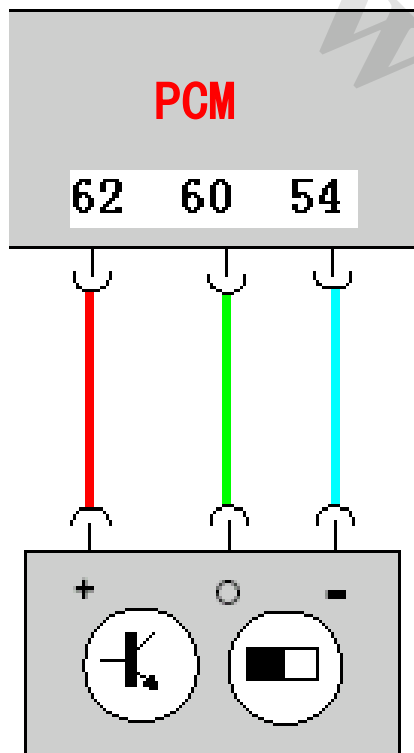

Schematic of Camshaft Position Sensor

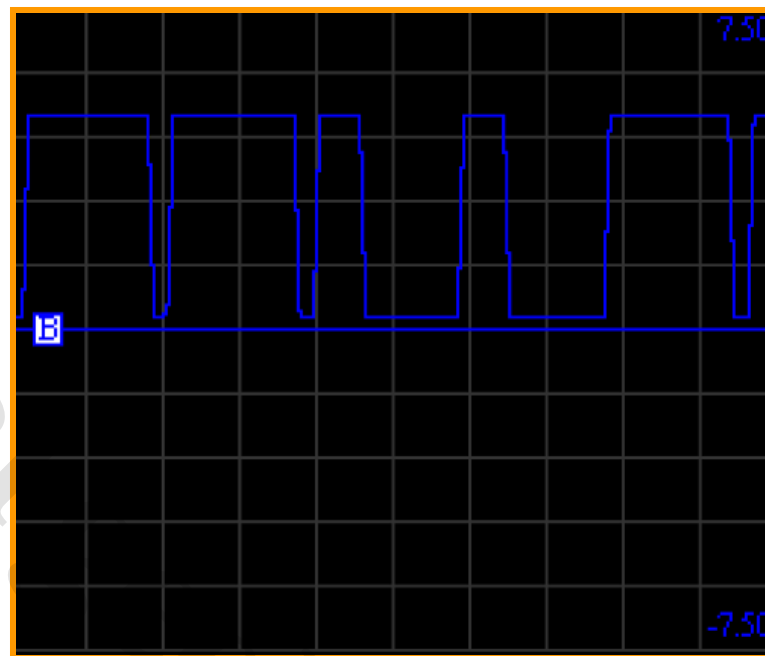

Detected with oscilloscope

3.1 Location & Function of Component



- **Location:** Under the instrument of driver, above the pedal accelerator.
- **Function:** Reflect the location of the pedal accelerator in the way of electronic signal to ECM, ECM controls the action of electronic throttle valve by calculation.

3. Accelerator Pedal Position Sensor

3.2 Throttle System of Engine

Electronic Throttle Control System:

- Accelerator pedal module with accelerator pedal position sensor
- Throttle control module
- Engine control unit
- Fault-indicating lamp of electronic throttle control system
- Brake lamp switch
- Brake pedal switch
- Clutch pedal switch and others

Close-loop Control

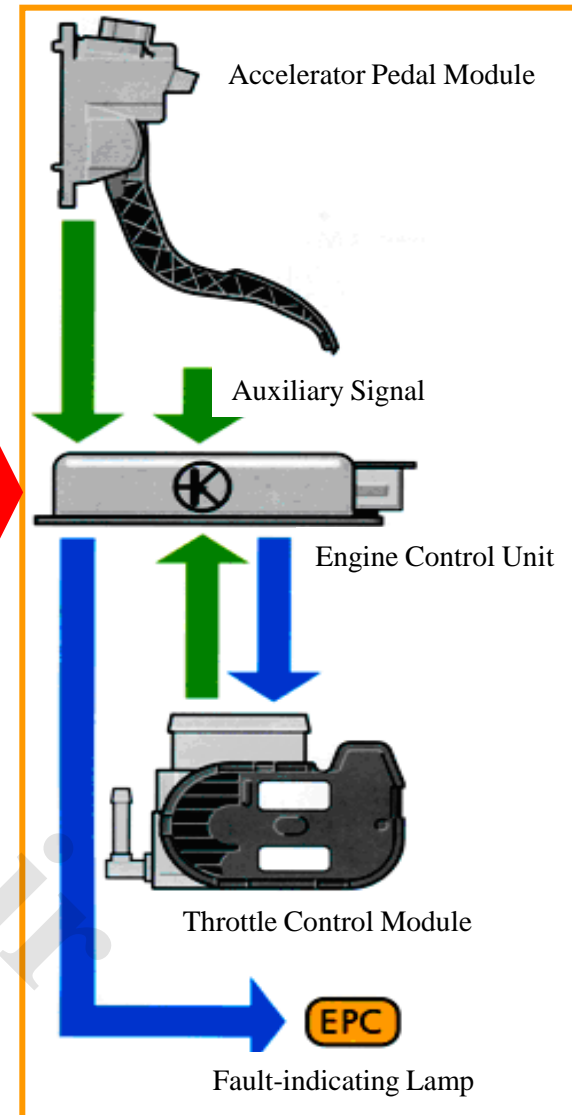

3.3 Detection of Accelerator Pedal Position Sensor

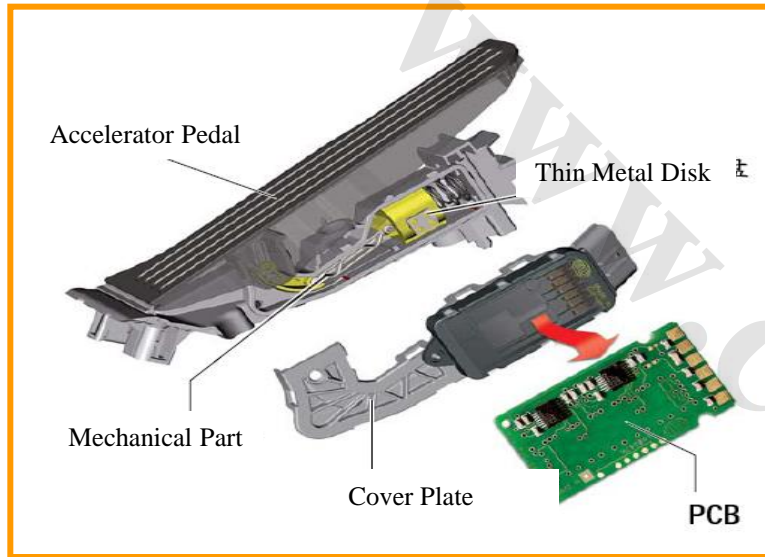

➤ Structure:

Pedal Mechanism

Wiper

Pedal Position Sensor- 1

Pedal Position Sensor- 2

➤ Interruption of Sensor Signal:

- When a sensor signal is distorted or interrupted, if another sensor is in the idle position, then the engine will be in the idling condition; if it is in the loading condition, then the engine speed will increase slowly.
- If two sensors break down simultaneously, then the engine operates in the high idle(1500r/min).

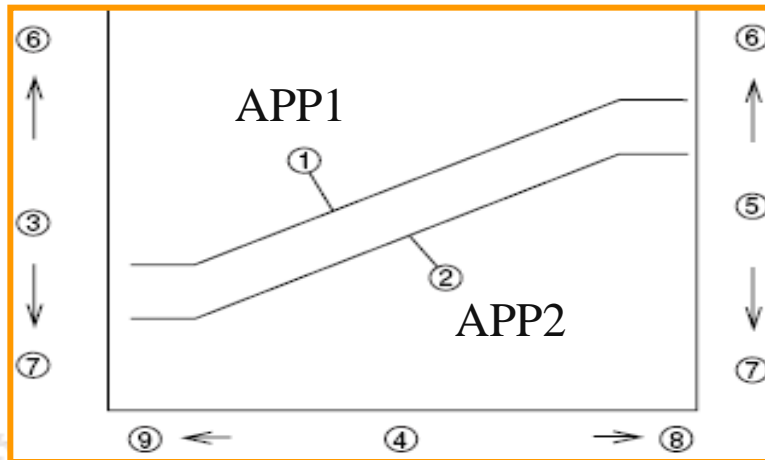

3. Accelerator Pedal Position Sensor

Continued the Picture Above

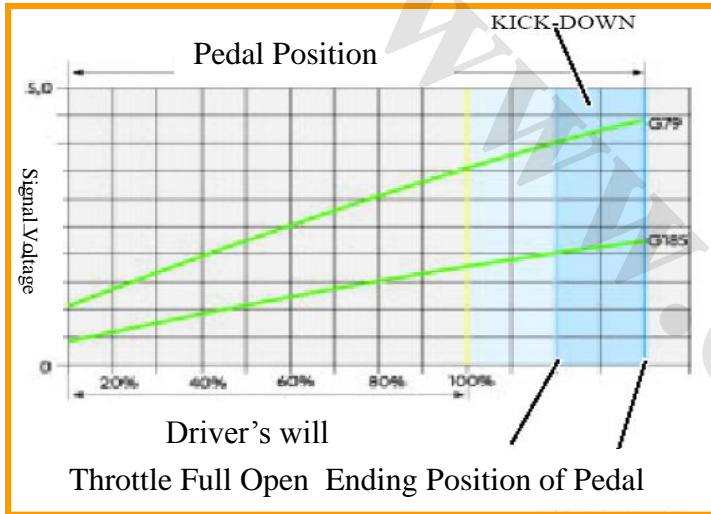

➤ Simple Detecting Methods:

- Turn up the ignition switch, not start, not step on the accelerator pedal, the output voltage signals of sensor APP1/APP2 as follows:
APP1: 2.18 V; APP2: 0.21V
- Turn on the ignition switch, not start, step on the accelerator pedal to the end, the output voltage signals of sensor APP1/APP2 as follows:

APP1: 4.71V ; APP2: 0.84V

The data above is measured by the diagnostic equipment when the engine is in the common state, for the reference.

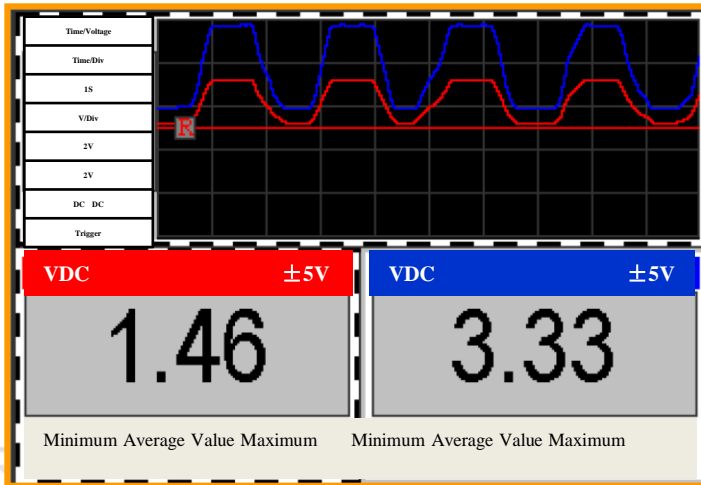

3. Accelerator Pedal Position Sensor

Continued the Picture Above

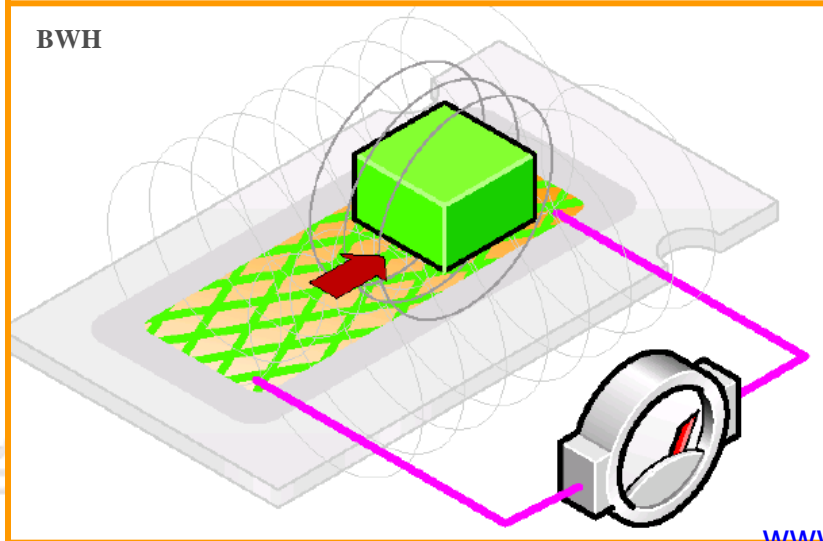
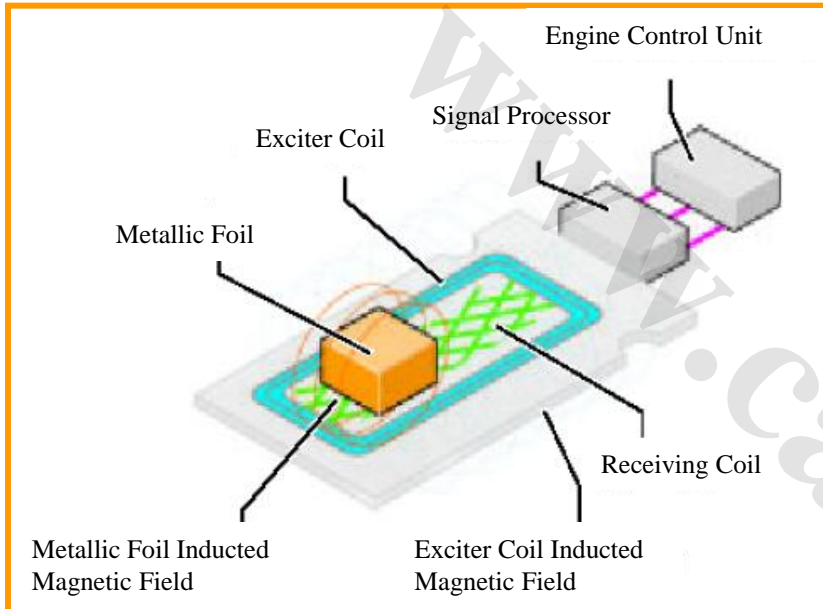

➤ Advantage:

No friction in the process of moving sensor, enduring, forced low profile is not required as the basic setting in the integral sensor.

➤ Impact of Failure :

- One or two are invalid, the memory will be stored in the system, the MIL of the instrument will be lighted up.
- There are some convenient functions in the vehicles, such as constant speed cruising system or auxiliary control function of engine braking will be invalid.
- A sensor signal is distorted or interrupted, if another sensor is in the idle position, then the engine will be in the idling condition; if the sensor is in the loading condition, the engine speed will increase slowly.
- If the two sensors are invalid simultaneously, then the high idle(1500r/min)/fast idling.

3. Accelerator Pedal Position Sensor

3.4 Schematic of Accelerator Pedal Position Sensor

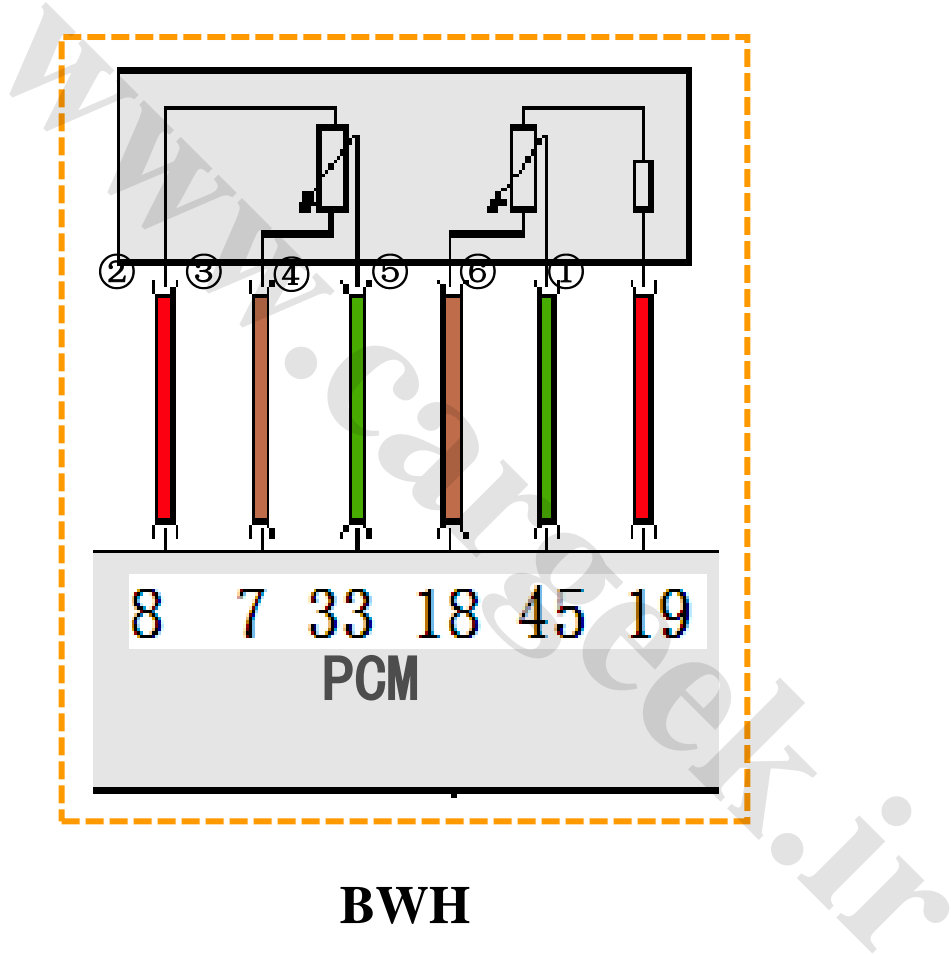

4.1 Location & Function of Component

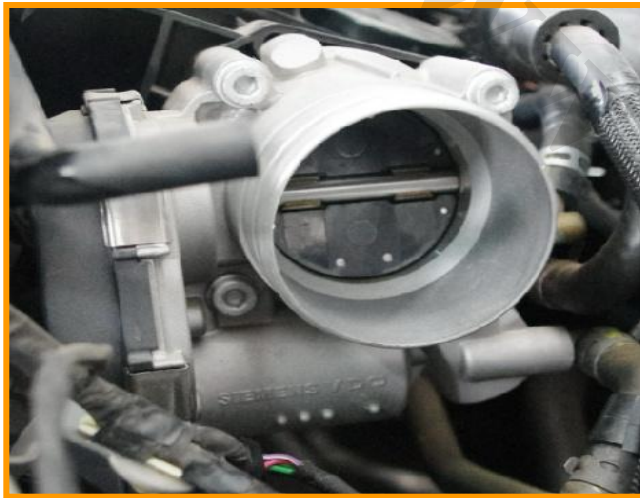

- **Location:** Throttle position sensor is located on the electronic throttle.
- **Function:** Throttle position sensor is used to detect the position of throttle and actuating motor.
- **Component Performance**
- **Main Constructions:**
 - Throttle Body
 - Driving Motor
 - Throttle Position Sensor
- Wipers of two potentiometers are combined directly with throttle valve shaft. One of the potentiometers shows positive signal, and the other one shows negative signal.

4.2 Throttle Position Sensor BWH

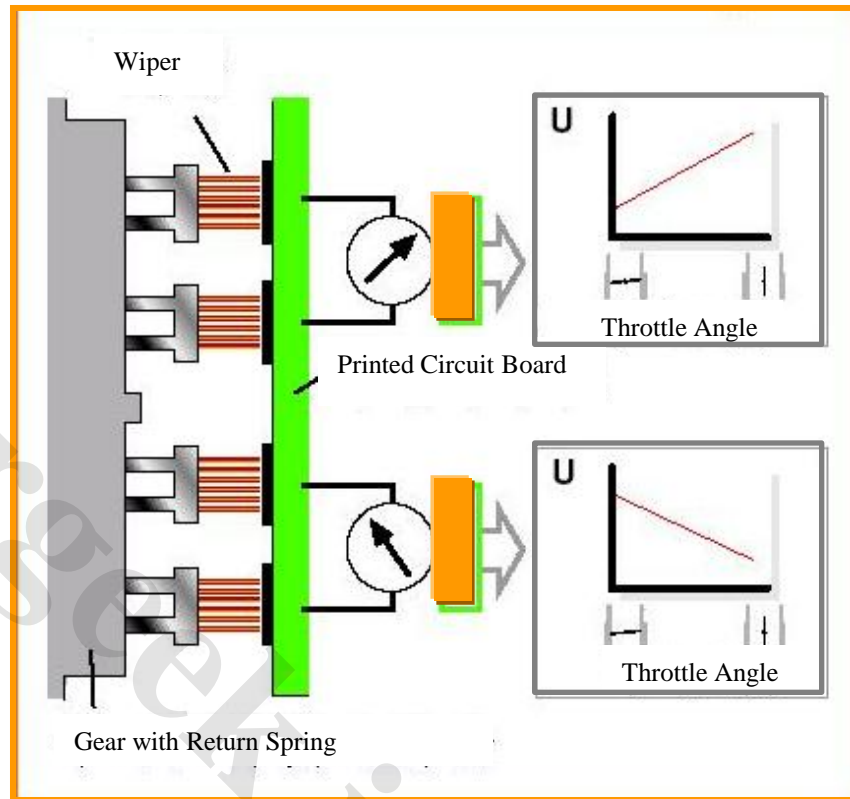
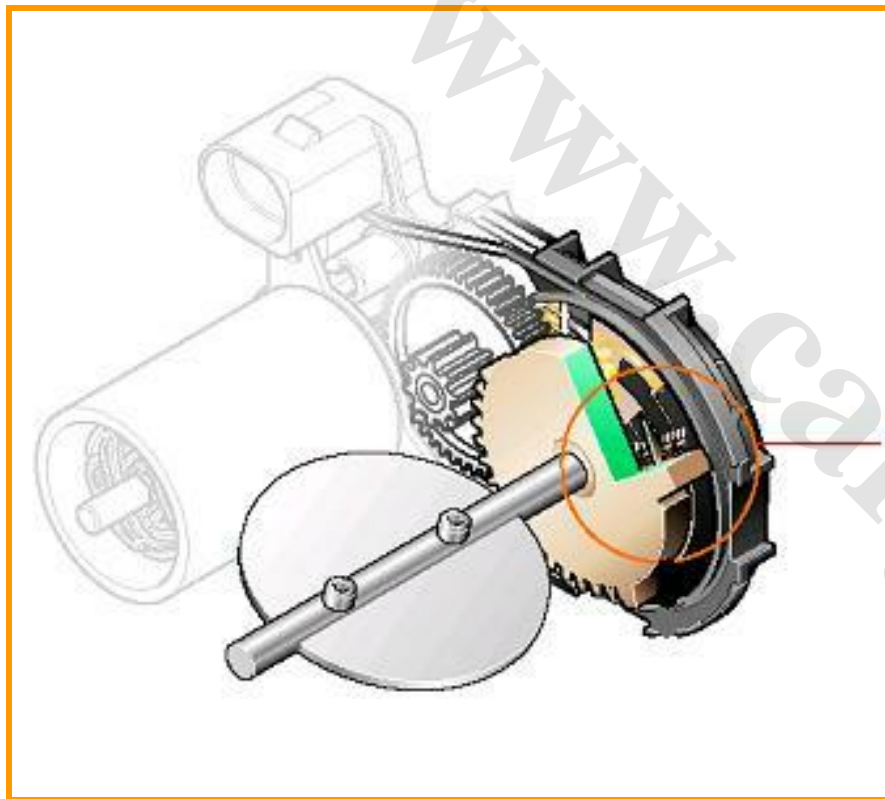

BWH

4.3 Circuit Structure & Detection of Throttle BWH

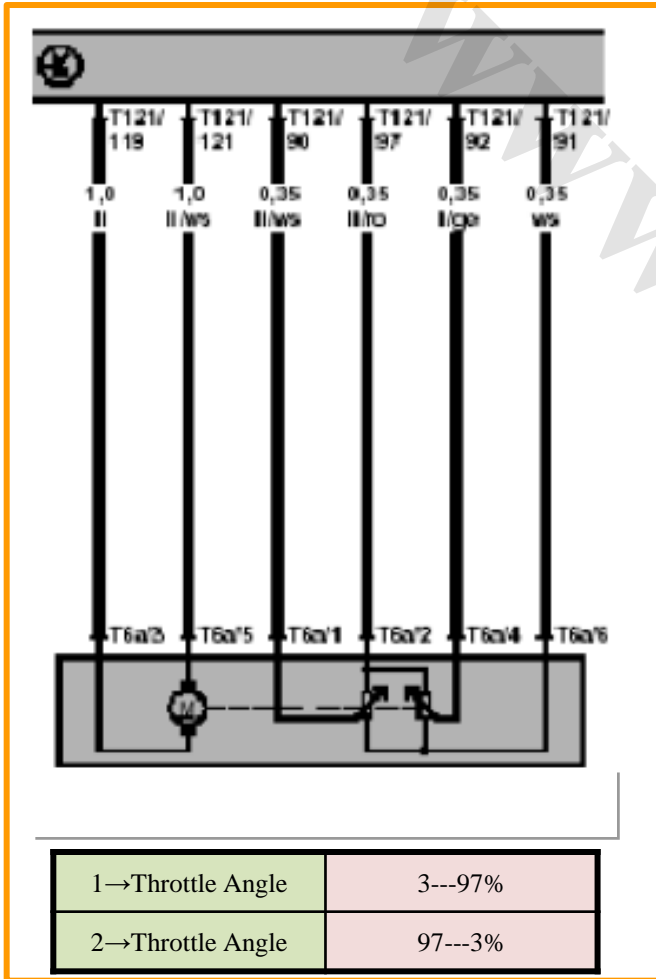

- Connecting Tester
- Step the accelerator pedal to the end slowly, observe the percentage of display space 1&2
- The percentage of display space 1 should be increased stably, the tolerance range 3---97% is not used completely.
- The percentage of display space 2 should be declined stably, the tolerance range 97---3% is not used completely.
- The displayed value in display space 1 increases, but the displayed value in display space 2 declines, as potentiometer of throttle control unit can be reversed.
- In other words: the signal voltage of sensor 1 is close to 5V(the wider the throttle opens, the higher the voltage will be) .
- The signal voltage of sensor 2 is close from 5V to 0V(the wider the throttle opens, the lower the voltage will be) .

Continued From Previous Page

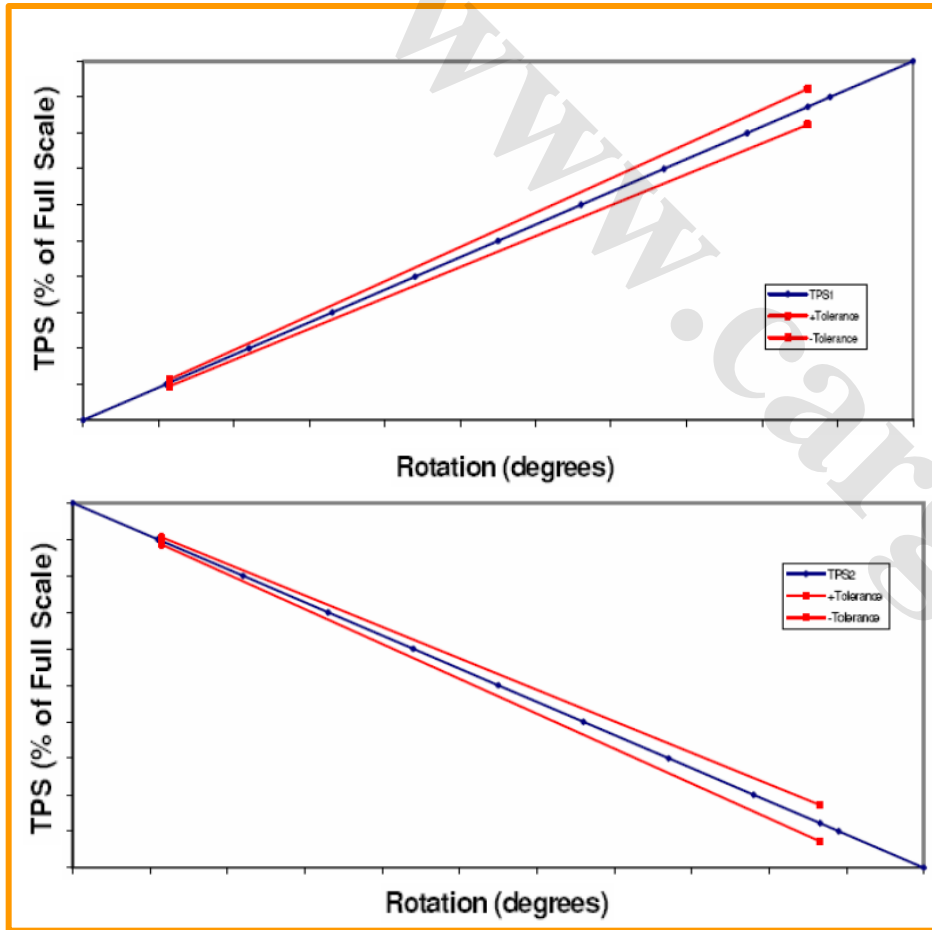

The sensor potential increases as the aperture varies.



The sensor potential declines as the aperture increases.

4.4 Failure Mode of Throttle Position Sensor

- A sensor is invalid (error/no signal)
 - Memorize fault, and light up the fault indicating lamp
 - Turn off the subsystem that has influence on torque
 - The remained signal detects load
 - Pedal responses normally
- Two sensors are invalid (error/no signal)
 - Memorize fault, and light up the fault indicating lamp
 - Turn off the actuating device
 - Fast idling, the pedal is invalid

5. Engine Coolant Temperature (ECT) Sensor

5.1 Location & Function of Component



BWH

- **Location:** At the water outlet back of the engine cylinder block, and the up-outlet-pipe out of the thermostat.

5. Engine Coolant Temperature (ECT) Sensor

5.2 Component Principle

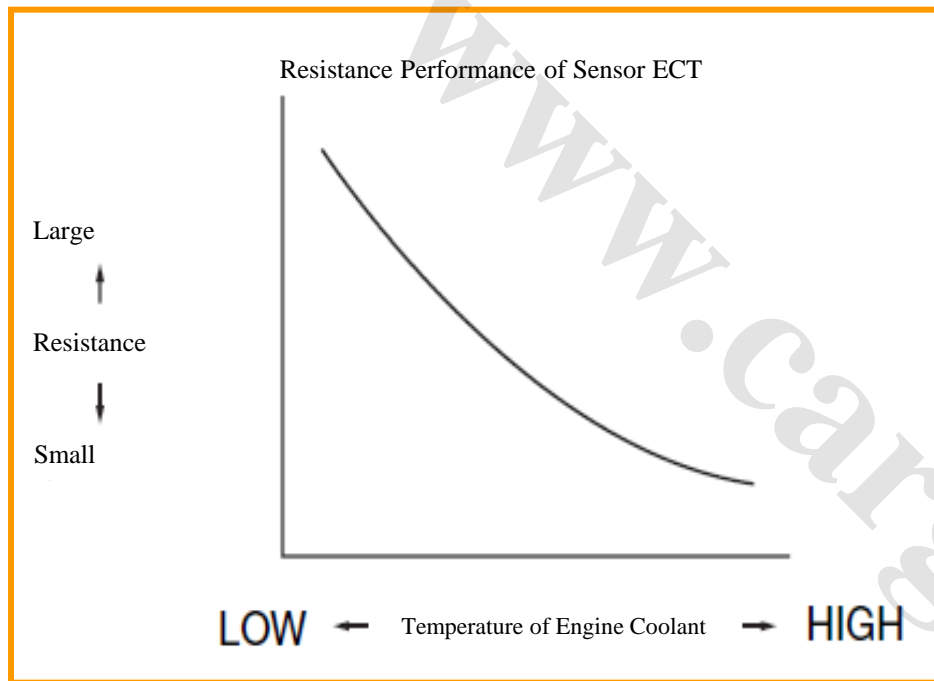

- Negative Temperature Coefficient (NTC) type thermistor.
- Resistance value declines as the temperature of coolant increases, but they are not with the linear relationship.

5. Engine Coolant Temperature (ECT) Sensor

5.3 Component Detection

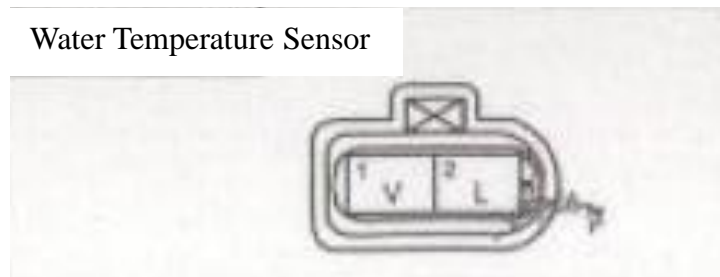
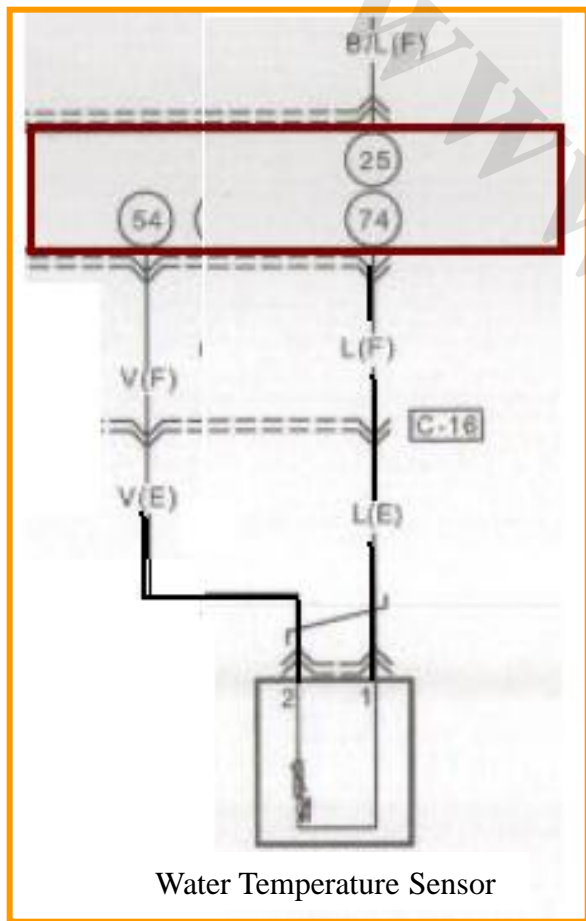

Multimeter Detection

Disconnect the connector, turning the digital multimeter to the ohm shift, two pens are connected with sensor pins 1&2, the nominal resistance in 20°C is $2.5k\Omega \pm 5\%$.

5. Engine Coolant Temperature (ECT) Sensor

www.CarGeek.ir



5.4 System Fault Lead By the Components

If the failure occurs, here are the following symptoms:

- Cold Start Problem
- Hot Start Problem
- Poor Driving Performance
- If the circuit from sensor to main power is short-circuit, then the engine will operate in default value
- Thermometer readings is too high
- Thermometer readings is too low
- Continue operating cooling fans in fast mode
- When the temperature is indicated low, high-temperature warning light will flash



6. Temperature-Manifold Absolute Pressure Sensor

6.1 Location & Function of Component



➤ **Location:** On the manifold assembly

➤ **Performance**

Operating Voltage	Operating Current	Output Voltage	Output Impedance
5V	Maximum 12mA	: -100- 100mV	<10Ω

6. Temperature-Manifold Absolute Pressure Sensor

6.2 Operating Principle

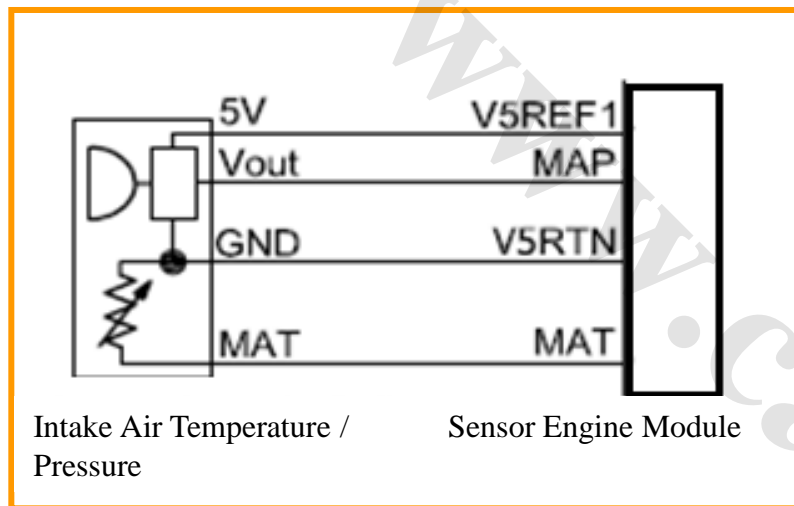

There is a sealing flexible diaphragm in the absolute pressure sensor MAP of the intake manifold, when the pressure changes, there will be an output signal occurred that is in direct ratio with the input voltage, and it is also of proportion with the reference voltage.

6. Temperature-Manifold Absolute Pressure Sensor

6.3 Simple Measuring Methods

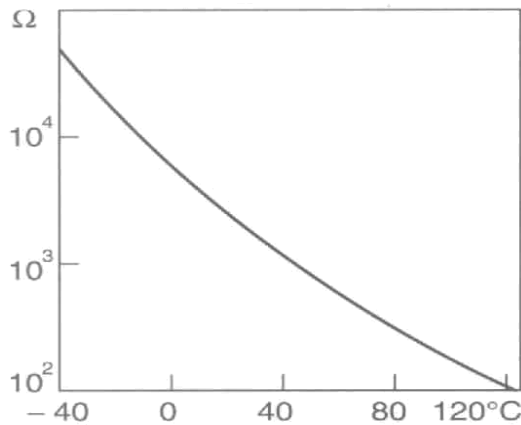
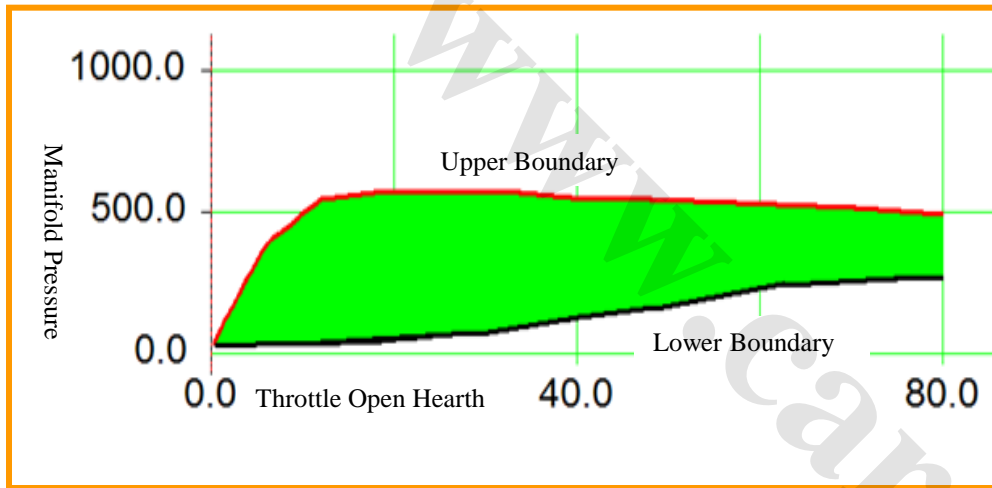

- Pressure Sensor Part: The voltage of the idling operation signal pin with the voltage shift of multimeter is about 1.3V the no-load condition, open the throttle slowly, the change in voltage of pin 4 is little; open the throttle quickly, the voltage of pin 4 can arrive at 4V at once, then declines to about 1.5V.
- Temperature Sensor Part: Measure the resistance between GND and temperature signal pin with the ohm shift of multimeter, it should be $2.5k\Omega \pm 5\%$ in 20°C , other corresponding resistance values can be measured from the characteristic curve .

6. Temperature-Manifold Absolute Pressure Sensor

6.4 Sensor Waveform

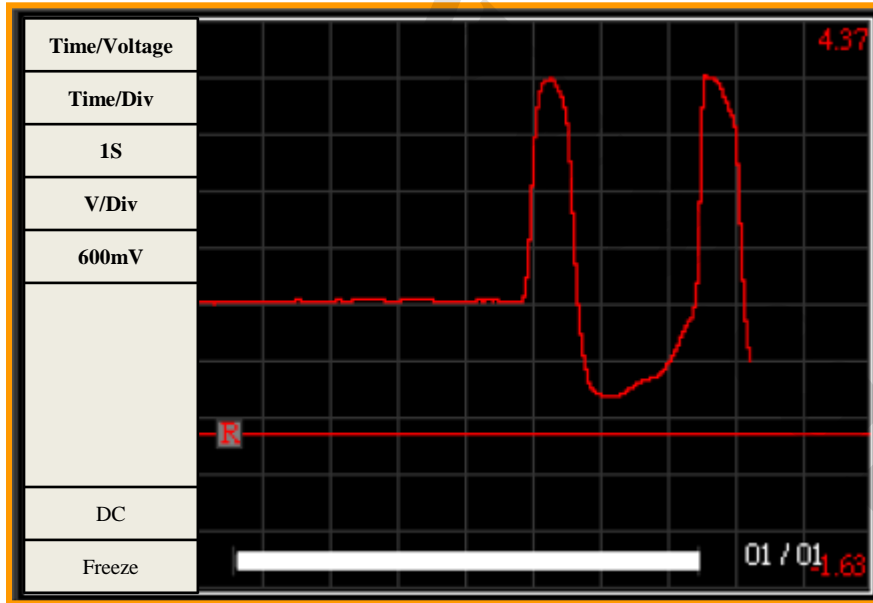

Emergency Refueling
Condition MAP

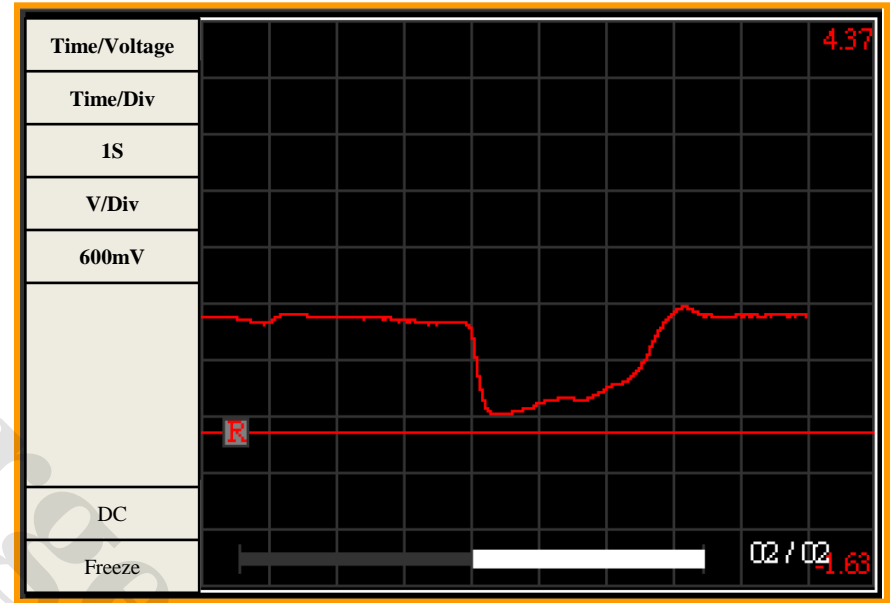

Deceleration Condition MAP

6. Temperature-Manifold Absolute Pressure Sensor

www.CarGeek.ir



6.5 Constructional Drawing of Circuitous Philosophy

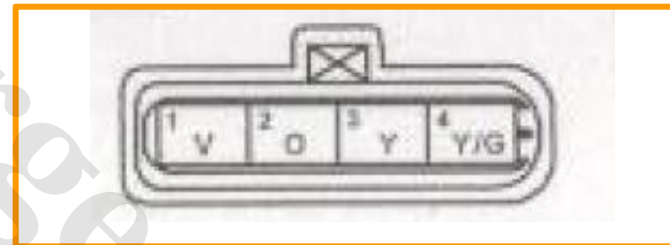
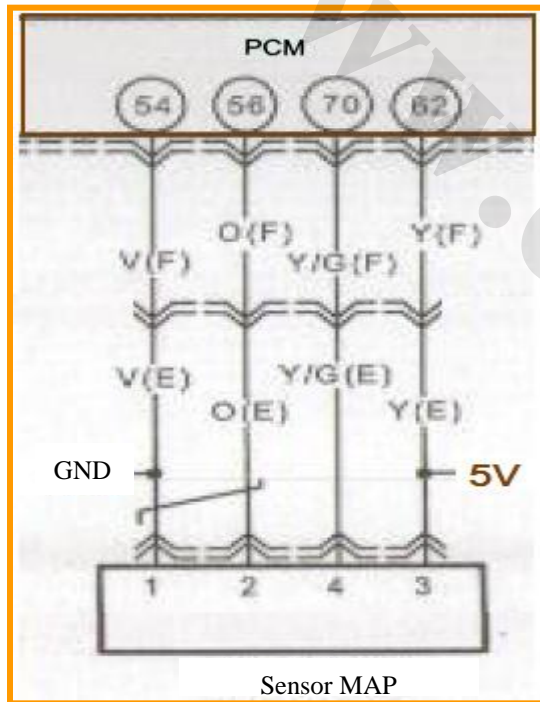

7.1 Location & Function of Components



➤ **Location:** There is a front oxygen sensor and a back oxygen sensor in the model BWH, the front oxygen sensor is located on the exhaust manifold; the back oxygen sensor is located behind the three way catalytic converter(TWC).

➤ **Function:** feedback the air mixture signal controlled by the closed loop

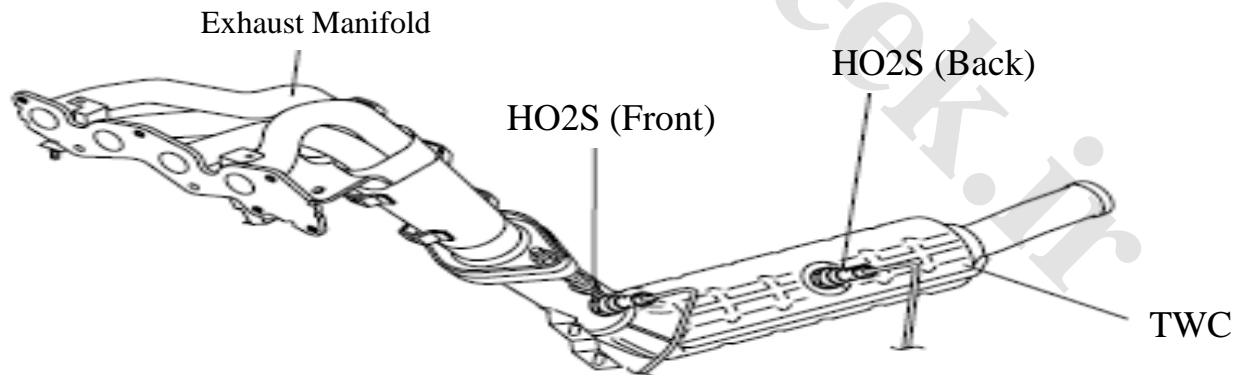

7.2 Component Performances

Temperature	260°C	450°C	595°C
Concentrated Output Voltage (mv)	>800	>800	>750
Diluted Output Voltage (mv)	<200	<200	<150
Dilute until the concentration response time(ms)	<75	<75	<50
Concentrate until the diluting response time (ms)	<150	<125	<90
Internal Resistance (Ω)	<100K		

7.3.1 Structure & Principle of Components

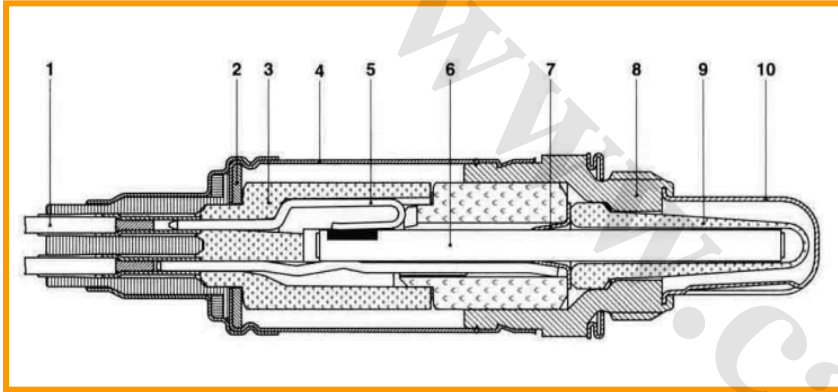

1. Cable
2. Cupped Washer
3. Insulating Bush
4. Protective Case
5. Clamp Coupling of Heating Component
6. Heating Rod
7. Contact Pad
8. Pickup Seat
9. Ceramic Probe
10. Protection Tube



7.3.2 Operating Principle of Oxygen Sensor

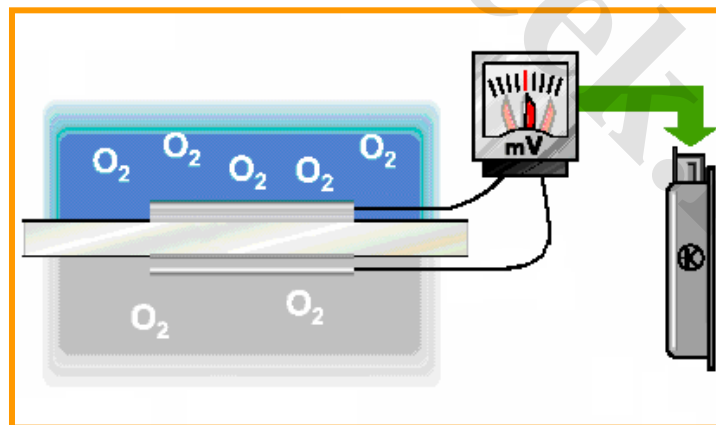
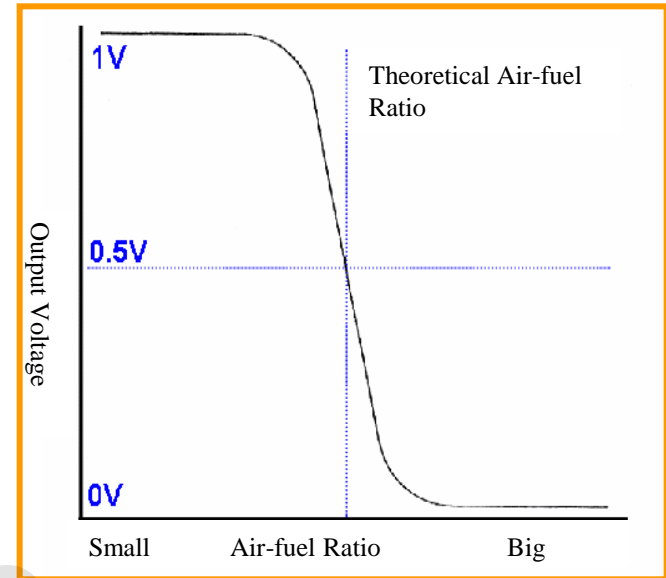
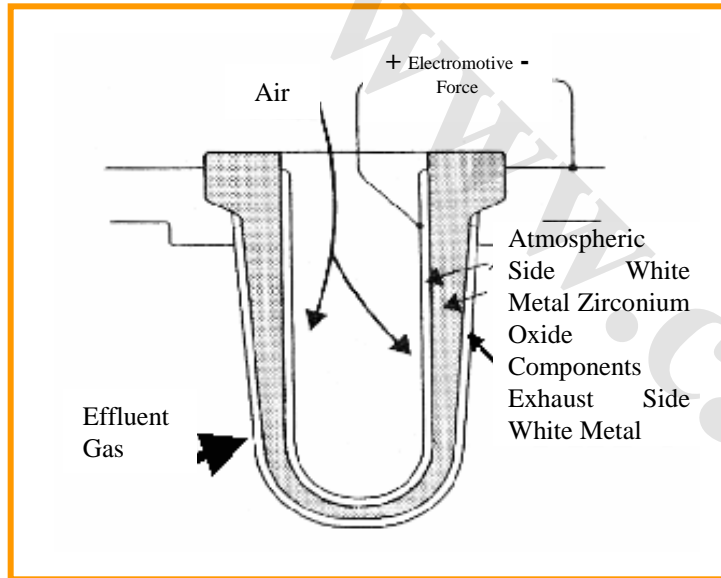

7.3.3 Operating Principle of Components

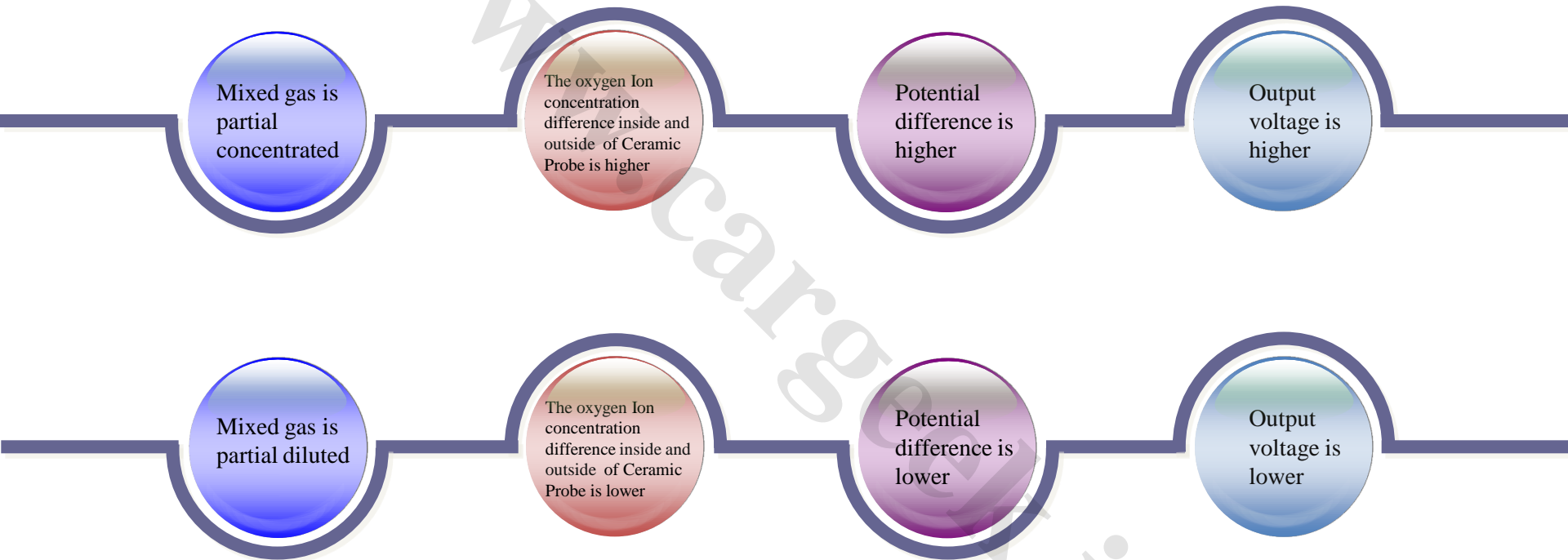

7.4 Component Detection

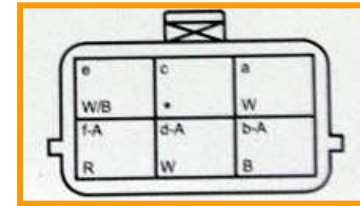
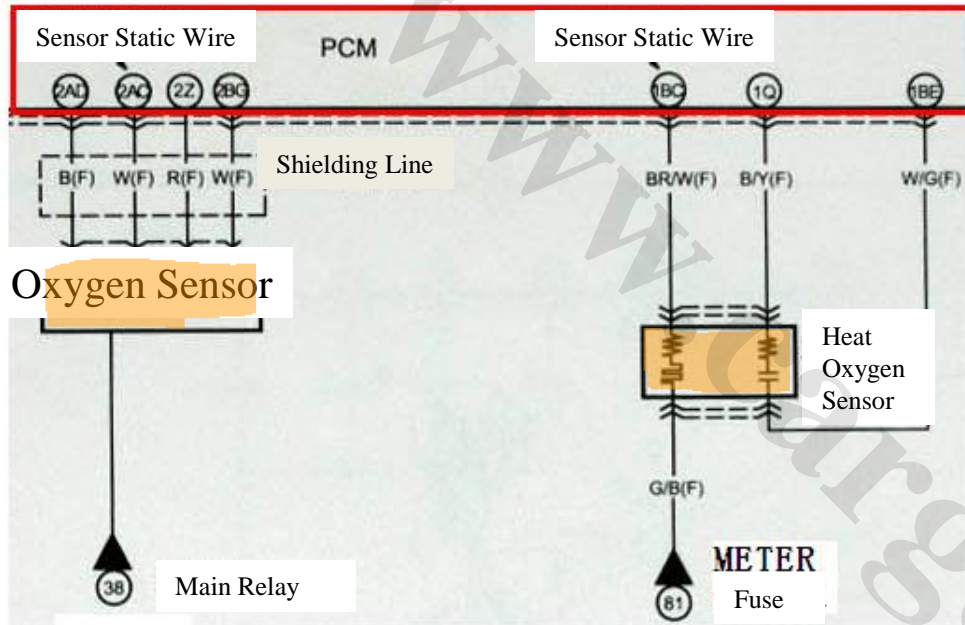

Front Oxygen Sensor

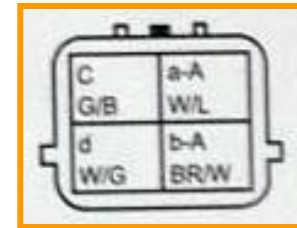

Sub -Oxygen Sensor

Disconnect the connector, turn the digital multimeter to the ohm shift, two pens of the instrument are connected with pins B & C of sensor (such as sub-oxygen sensor), then heat the resistance, the resistance value in the normal temperature is 8.2Ω (measured value).Connect the connector, in the idling condition, when the oxygen sensor reaches the operating temperature of 350°C , turn the digital multimeter to the direct-current voltage shift, two pens of the instrument are connected with pins A & D of sensor , the voltage should quickly vary in the range of 0.1-0.9V.

Component Waveform (Idle Speed)

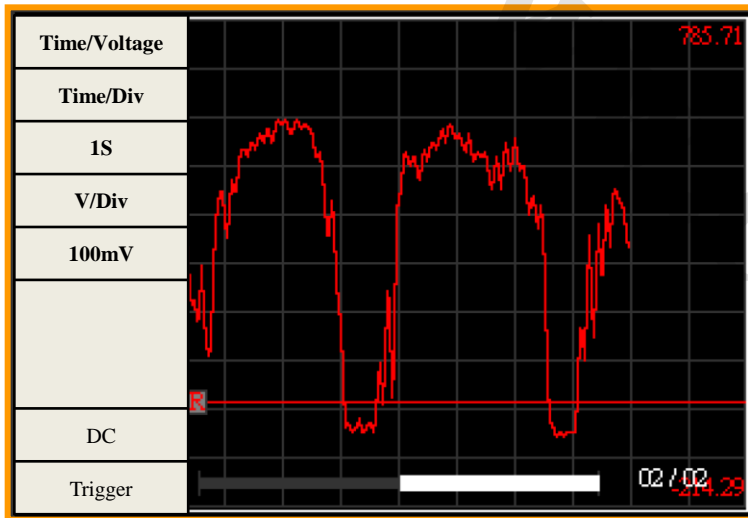

Component Waveform - Emergency Refueling

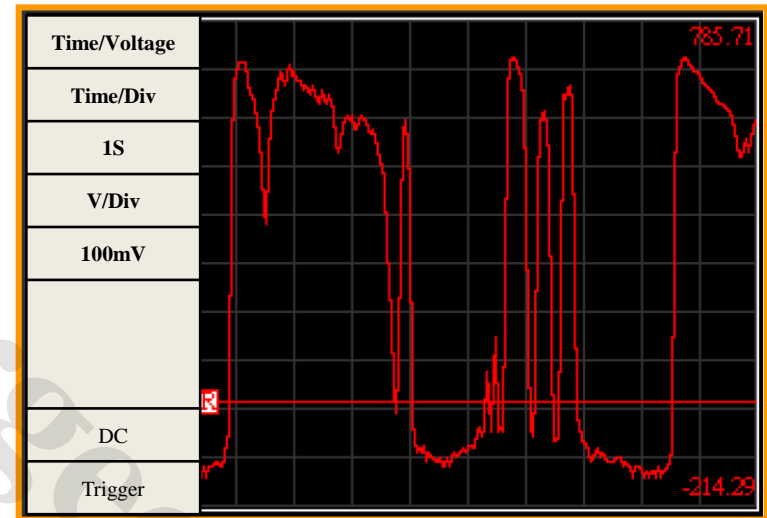

7.5 Oxygen Sensor Detection

- Deterioration diagnosis of oxygen sensor is only for Upstream O2S. The output will become slow when the oxygen sensor is poisoning or in performance degradation. The malfunction indicator lamp should be lighted up and the diagnostic trouble codes should be reported when emission led by the degraded oxygen sensor beyond the OBD limits.

- Diagnostic Method of Oxygen Sensor :

Through viewing the output waveform of the oxygen sensor:

Conversions of the oxygen sensor output between the concentration and dilution in the certain time, if the average time is too long, or the conversions are too little, then the oxygen sensor has been degraded.

7.6 Function of Sub-Oxygen Sensor

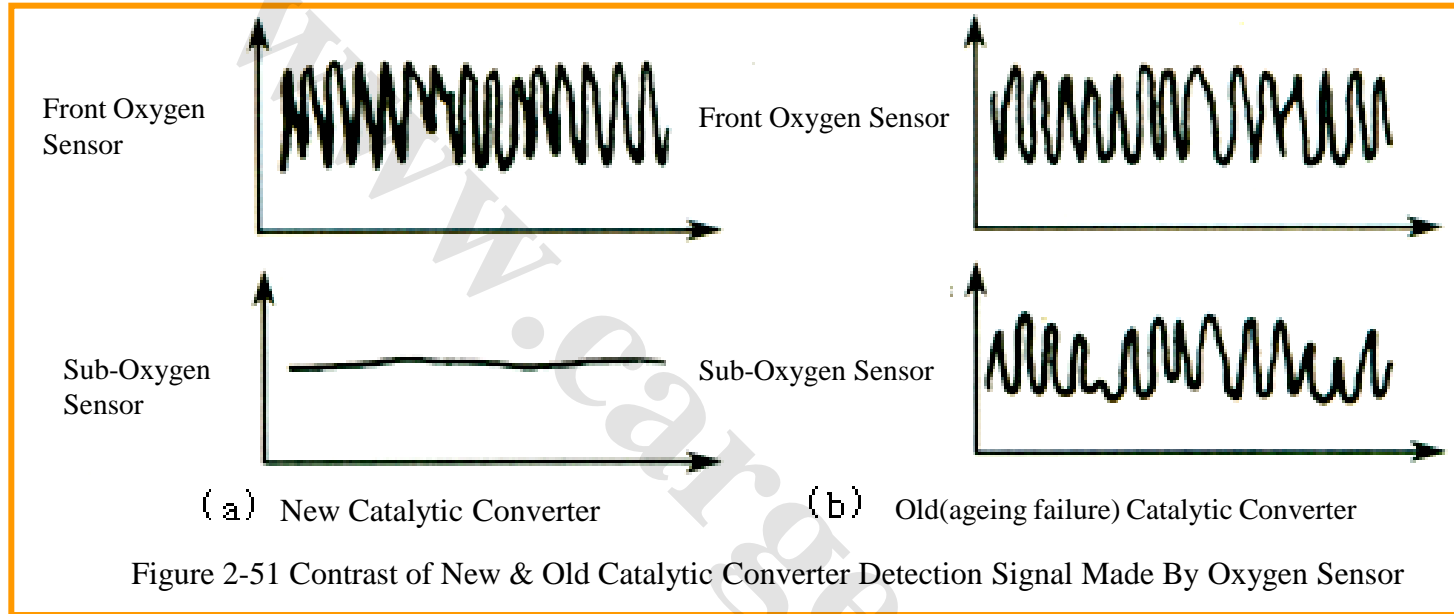

In order to detect the conversion efficiency of three-way catalytic converter, two oxygen sensors should be set.

When ECU is in the specific condition, the function of catalytic converters can be judged by comparing two signal fluctuation values of the two sensors. Generally, Catalytic converter is invalid when the signal waveform of sub-oxygen sensor is close to the front one.

8.1 Location & Function of Component



- **Location:** Underside of Intake Manifold.
- **Function:** Detect whether there is a knocking tendency in the air mixture of the engine combustion chamber, offer the knocking signal to ECM, in order to better control the spark advance angle
- **Performance**

Frequency Range	Resistance	Capacitance
3—18KHz	Larger than 1MΩ	1480—2220pf

8.2 Component Principle

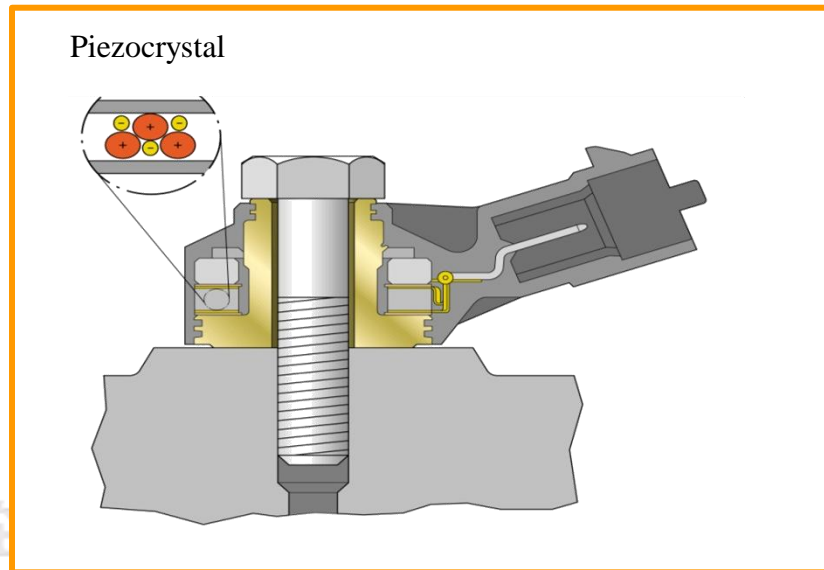
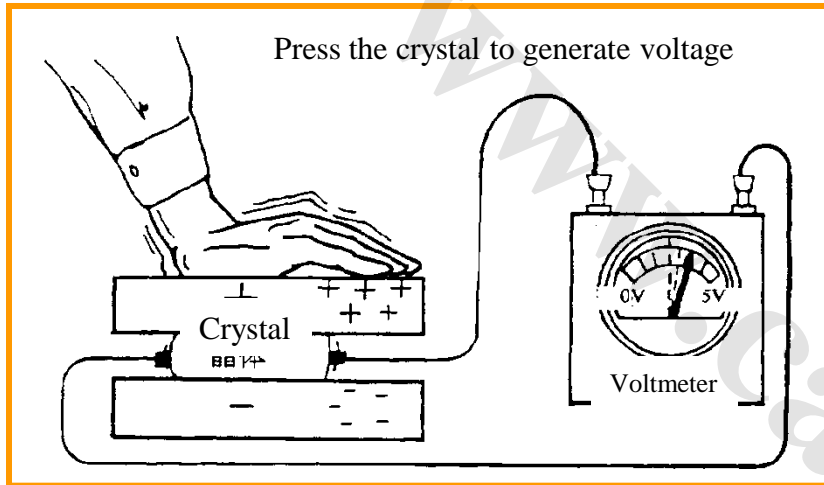

Knock sensor is a kind of acceleration type vibration sensor, it produces an output voltage corresponding with the engine mechanical vibration. The sensor involves a ceramic piezocrystal, which can produce voltage signals when vibrating. In the process of engine knocking, the vibration of crystal increases, so that it can change the signals output to ECM.

8.3 Component Detection

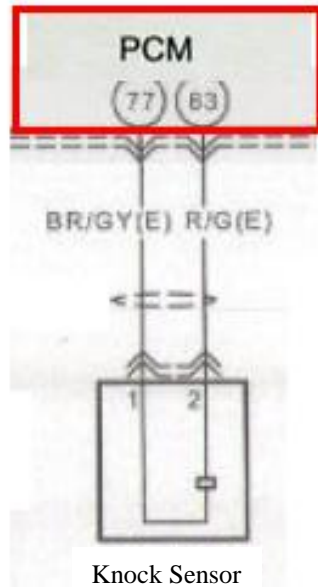

BWH

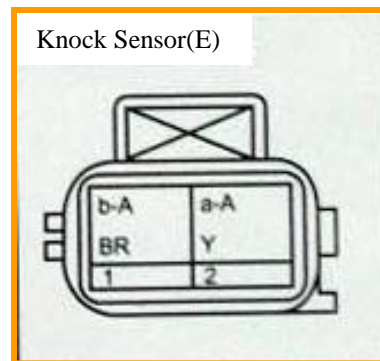

- Disconnect the connector, turn the digital multimeter to the ohm shift, two pens of instrument are connected to pins 1&2 of sensor, the resistance value should be larger than $1M\Omega$ in the normal temperature. Each connector is not allowed to be conducted.
- Turn the multimeter to the mv shift, knocking the engine cylinder block by the rubber hammer, then sensor voltage should be output, or knocking the sensor slightly (attention not to damage the sensor), then sensor voltage should be output.

www.cargeek.ir

Thank you!

奔腾 BESTURN

Technical Training of BESTURN B50

— Engine output system control

奔腾 BESTURN

Suitable post: Technical Director

Curriculum Goals

- Understand structure and principle of the engine module control output
- Master measurement and inspection method of the ignition part
- Master measurement and inspection method of the throttle and idle speed
- Master measurement and inspection method of the fuel system with injection.

Contents

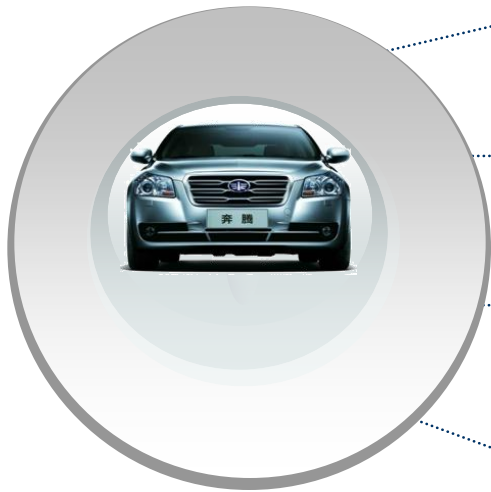

1、 Engine BWH control output strategy

2、 Ignition control

3、 Throttle and idle speed control

4、 Fuel supply and injection

1.1. Composition of engine management system

System input component

- 1 Oxygen sensor(HO2S)
- 2 Engine coolant temperature sensor (ECT)
- 3 Camshaft position sensor (CMP)
- 4 Crankshaft position sensor (CKP)
- 5 Brake pedal position sensor
- 6 Engine anti-theft module
- 7 A/C high, medium and low pressure switch
- 8 Throttle position sensor (TPS)
- 9 Accelerator pedal position sensor (APP)
- 10 Vehicle speed sensor (VSS)
- 11 Knock sensor (KS)
- 12.Manifold air pressure sensor (MAP)
- 13.Manifold air temperature sensor (MAT)

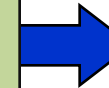
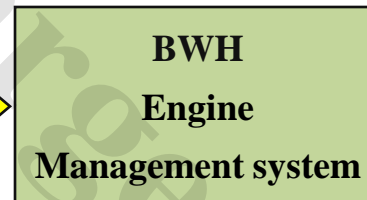
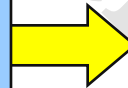

System output component

1. Oxygen sensor heating
2. Ignition coil
3. Electromagnetic fuel injector
4. Electronic throttle drive motor
5. Carbon canister control valve
6. Electric fuel pump
7. Air conditioning clutch
8. Cooling fan

1.2 Features of the engine management system

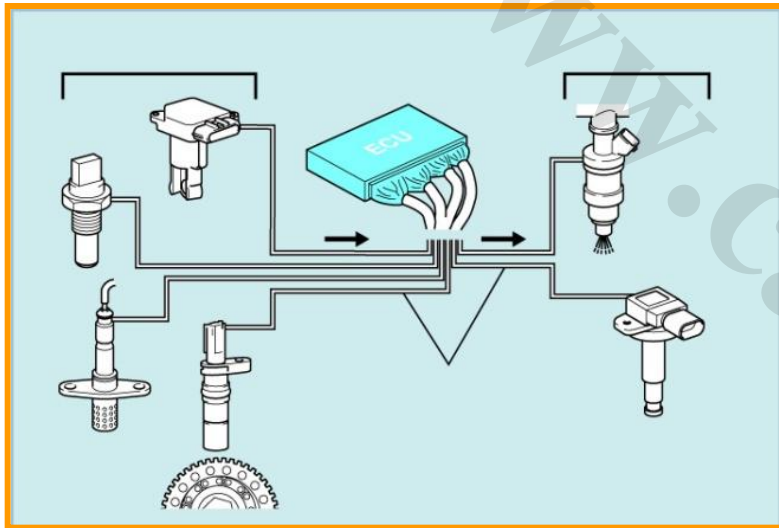

- Engine Thermodynamic air flow and temperature calculation
- Engine torque output control mode
- Vehicle main power relay control
- Closed loop control of multi - point sequential fuel injection
- Non-fuel return supply mode
- Fuel pump operation control
- PCM ignition driver module, no distributor grouping direct ignition
- Knock Control
- Electronic throttle control
- Air-conditioning control
- Cooling radiator fan control
- Canister solenoid valve control
- System self- diagnostic function
- PCM Antitheft Control

1.3 Fuel injection pulse width calculation

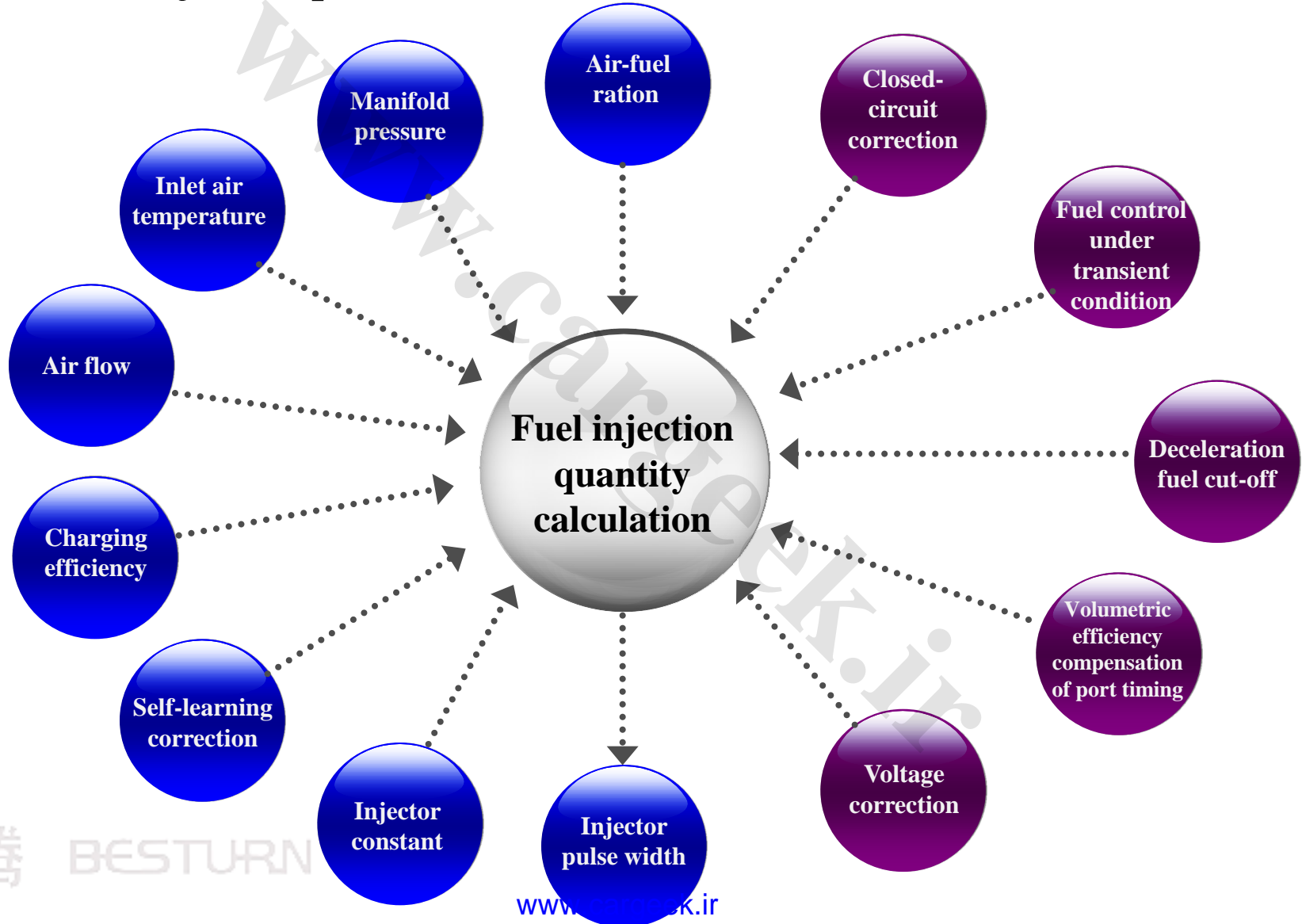

Continued

Air amount calculation

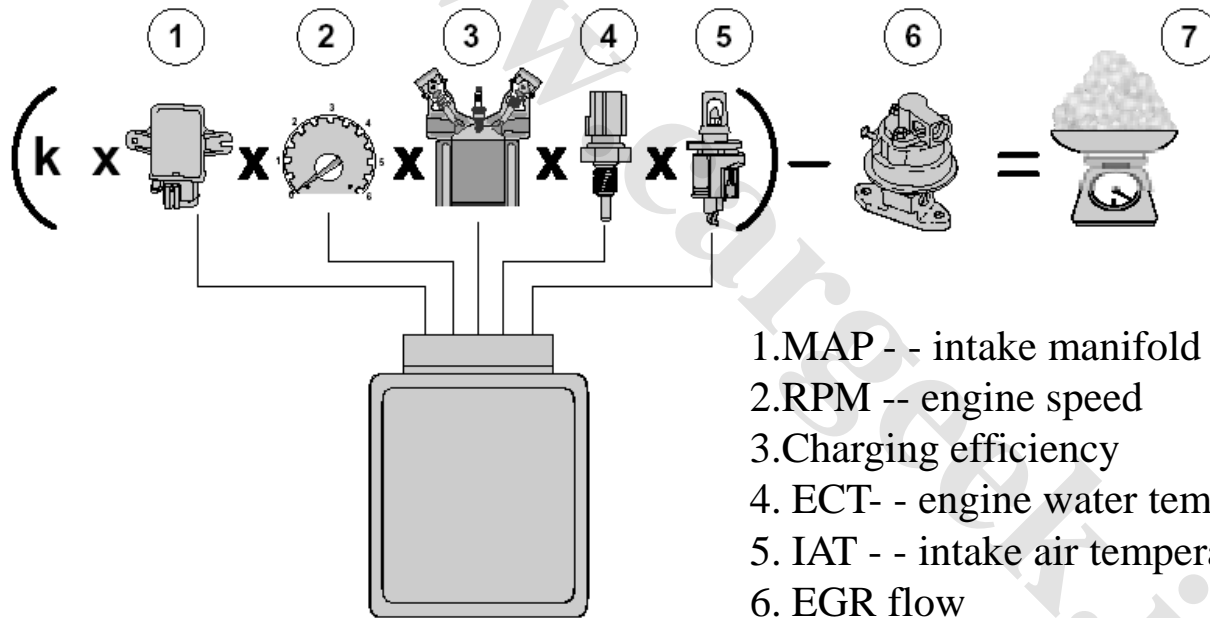

- 1.MAP - - intake manifold absolute pressure
- 2.RPM -- engine speed
- 3.Charging efficiency
4. ECT- - engine water temperature
5. IAT - - intake air temperature
6. EGR flow
- 7.Air intake flow

1.4 Pump control logic

Fuel Pump open logic:

Turn on the ignition switch and the pump will run for two seconds, if there is no effective 58X signal detected, the pump stops running, the engine began to turn, once the PCM detect the 58X signal then the pump will run.

Pump close logic:

The pump will stop running when lost speed signal for 0.6 seconds or requested by antitheft device.

1.5 Ignition advance angle calculation

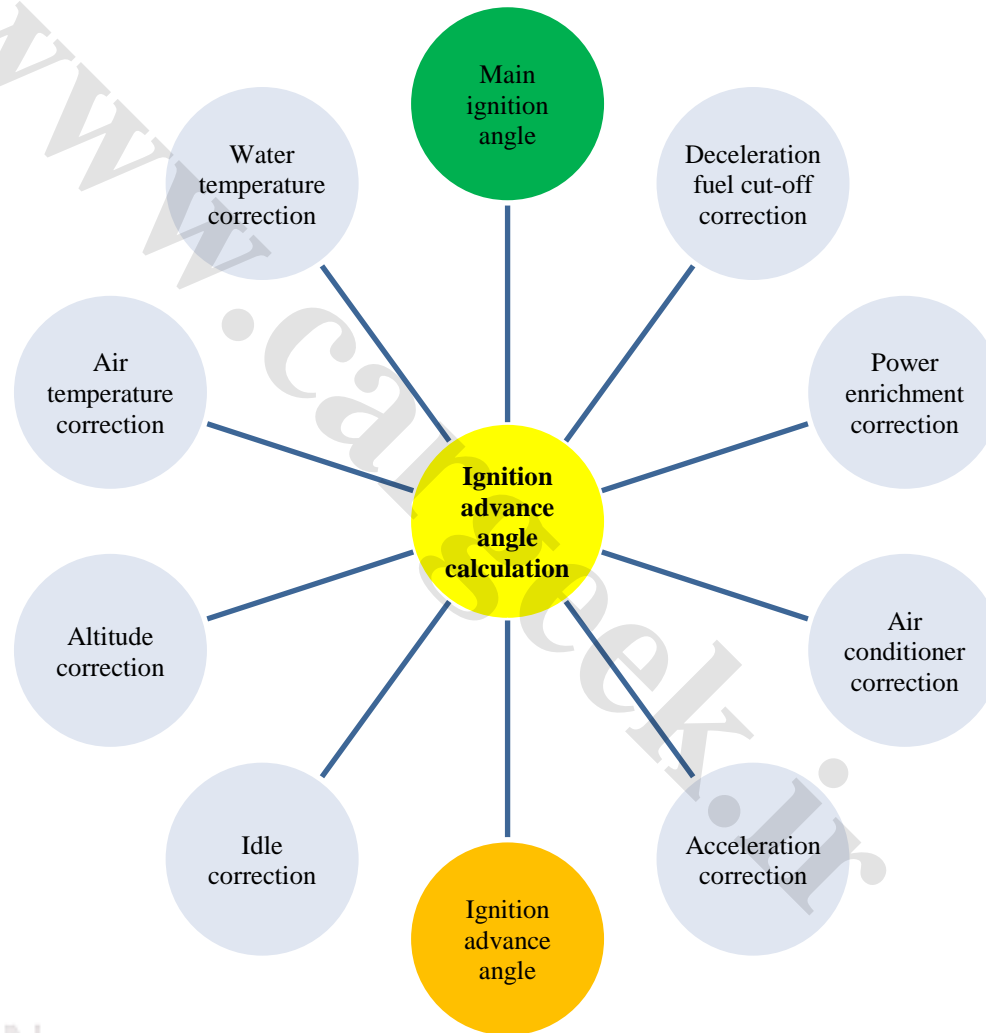

**Ignition advance angle
correction**



- Water temperature correction
- Air intake correction
- Altitude compensation correction
- Idle speed correction
- Accelerated correction
- Power enriched correction
- Deceleration fuel cut-off correction
- Air-conditioning control correction

Main ignition angle is the minimum ignition angle or knock the critical point (KBL) of optimal torque point (MBT) ,

1.6 Knock control logic

Working conditions of knock control

- Vehicle is equipped with knock sensor and start the knock control function
- The engine running time exceeds more than 2 seconds
- The engine water temperature is higher than 70 degrees
- Engine speed is greater than 800rpm

When system detect the knock condition, it will delay ignition advance angle of 3-5 degrees according to the different engine speed, and in the follow-up within 2-3 seconds to restore to the normal control.



1.7 Engine Idle and speed control

PCM adopts two idle speed control manners:

- Electronic throttle control (coarse adjustment))
- Ignition timing adjustment (fine adjustment)

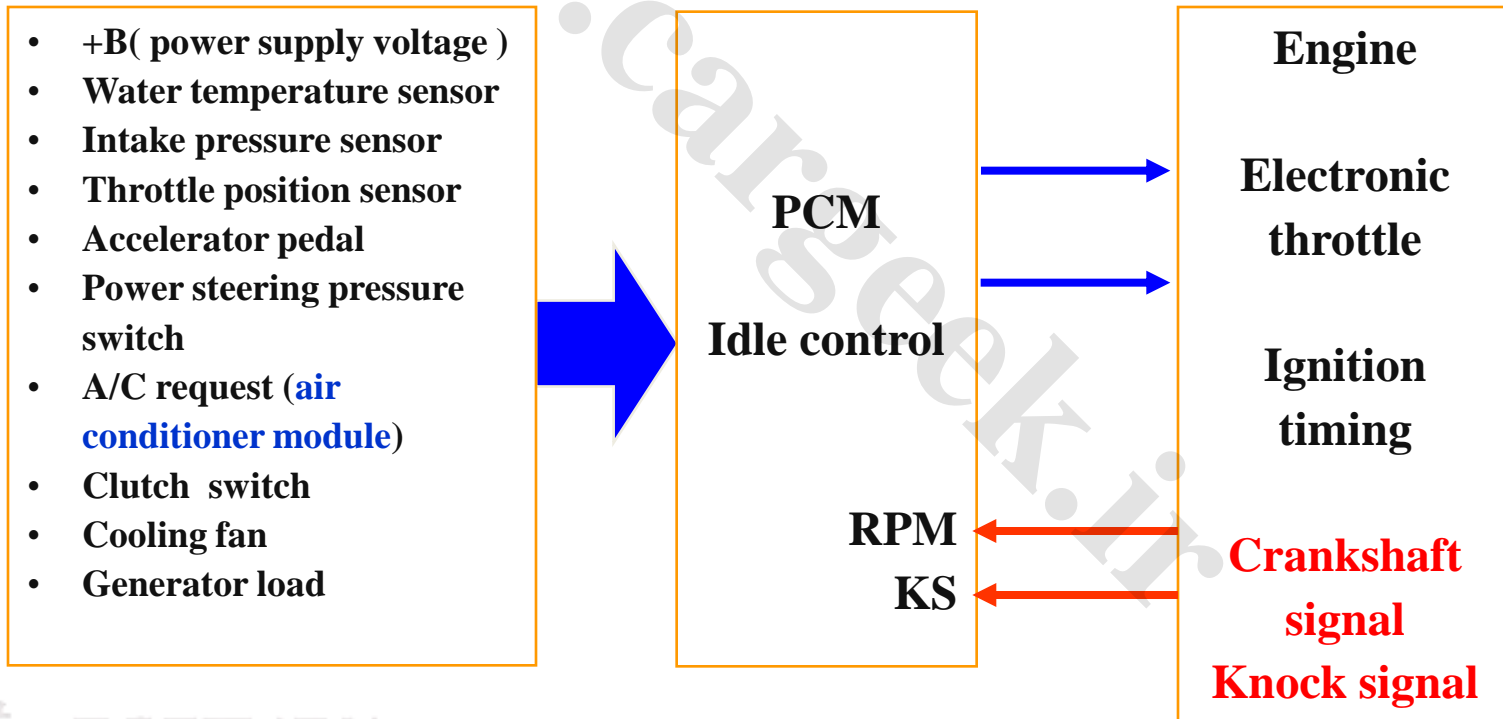

Target idle speed calculation

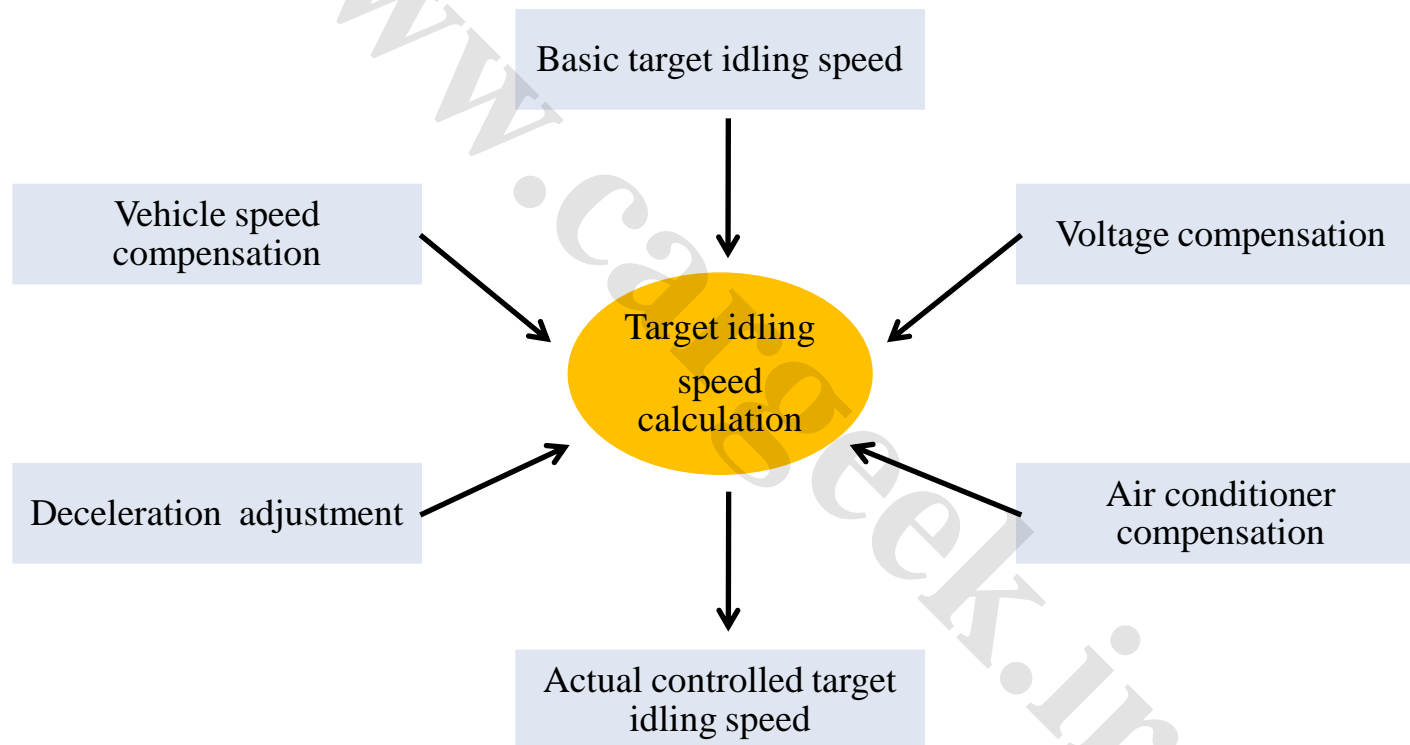

1.8 Throttle control

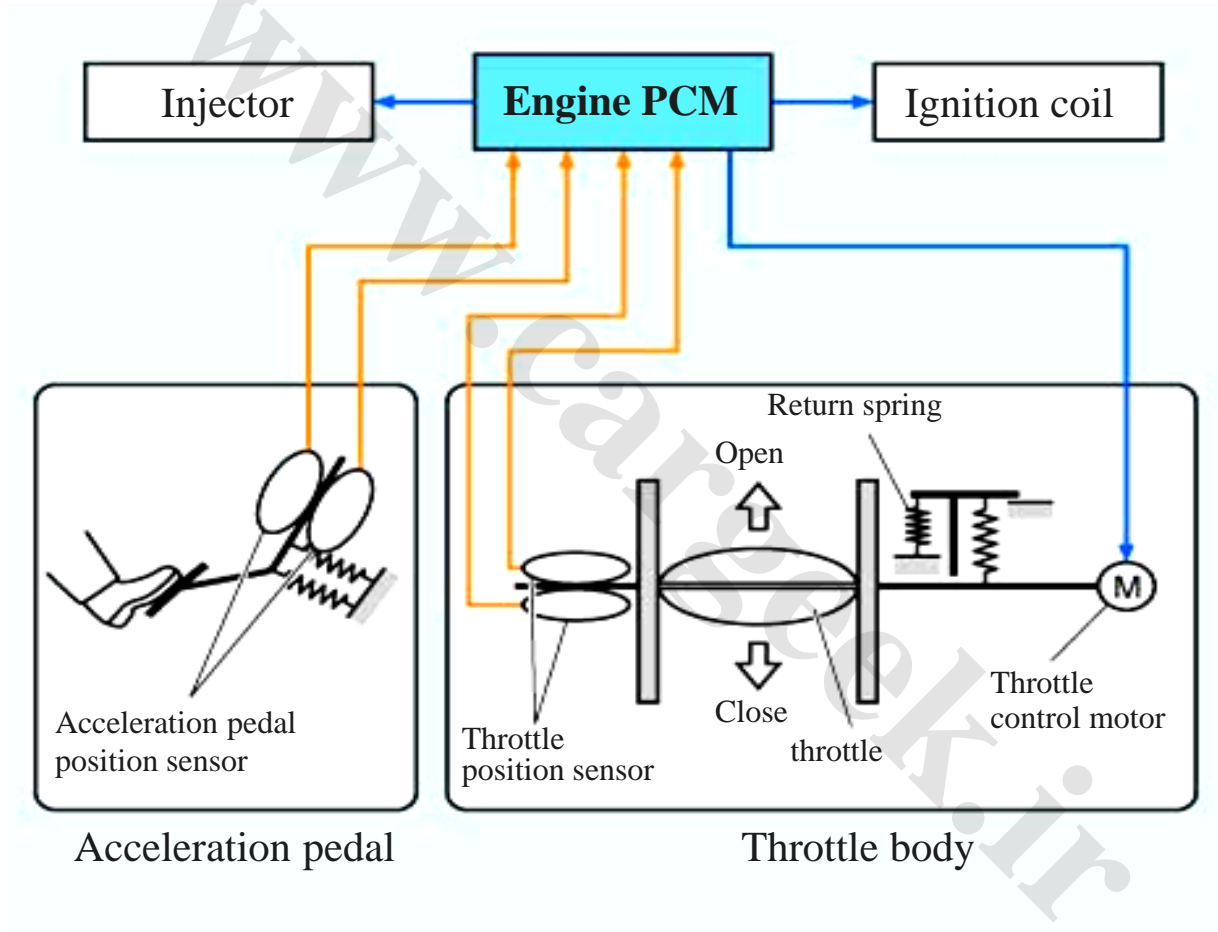

1.9 Air conditioner control

Air conditioner working condition

Air conditioning system will start under conditions below:

- Engine is running and the running time should exceed than 7 seconds
- Air-conditioning switch connected
- All air-conditioning mode cut-off does not work

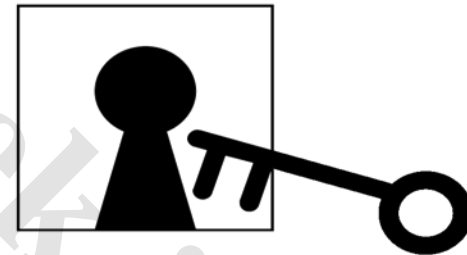

Air conditioner cut-off mode

High engine speed air conditioner cut-off mode: protect air conditioner system

A/C off , only when engine speed is less than 4900rpm to allow the compressor to start

A/C work , when engine speed is higher than 4900rpm to cut-off the compressor

High coolant temperature air conditioner cut-off mode: protect air conditioner system

A/C off , only when coolant temperature is less than 106°C to allow the compressor to start

A/C work , when coolant temperature is higher than 108°C to cut-off the compressor

Low air conditioning evaporator temperature air conditioning cut-off mode: protect air-conditioning system.

Vehicles will enter the high ambient temperatures start air conditioning cut-off mode when any of the following conditions are met:

The air conditioning evaporator temperature sensor failure

The air conditioning evaporator temperature is less than 3 °C



When the following two conditions are met, the vehicle will exit low air conditioning evaporator temperature cut-off mode: □

The air conditioning evaporator temperature sensor is normal

The air conditioning evaporator temperature is greater than 4 °

1.10 Canister solenoid valve control logic

Canister solenoid valve to open must meet the following conditions:

- The system pressure is lower than 18V , greater than 8V
- Engine water temperature higher than 0 ° C
- The engine intake air temperature higher than 0°C
- No relative system failure



- Fuel system failure
- Pump failure
- High / low idle speed failure
- Engine fire failure
- Front oxygen sensor heating failure
- Rear oxygen sensor heating failure
- Crankshaft position sensor failure
- Ignition coil failure
- fuel injector failure
- Canister solenoid valve output fault

Canister solenoid valve opening is determined by PCM according to duty ratio (PWM) signal which is determined by engine status.

1.11 Fan control logic

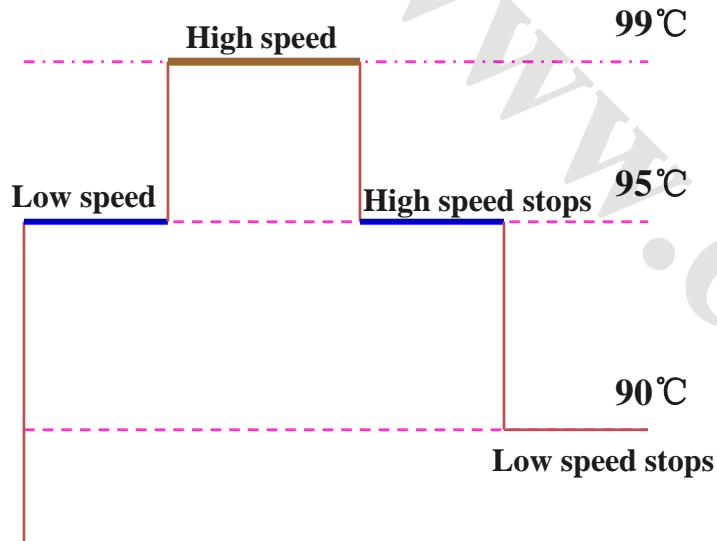

Fan work style and condition

- ◆ When the water temperature is higher than 95 °C , low-speed fan will start running
- ◆ When the water temperature is higher than 99 °C , high-speed fan will start running
- ◆ When the water temperature is lower than 95 °C , high-speed fan will stop running
- ◆ When the water temperature is lower than 90 °C , low-speed fan will stop running
- ◆ Air conditioning fan will start to run when air conditioner is turned on

2.1 Component location and function

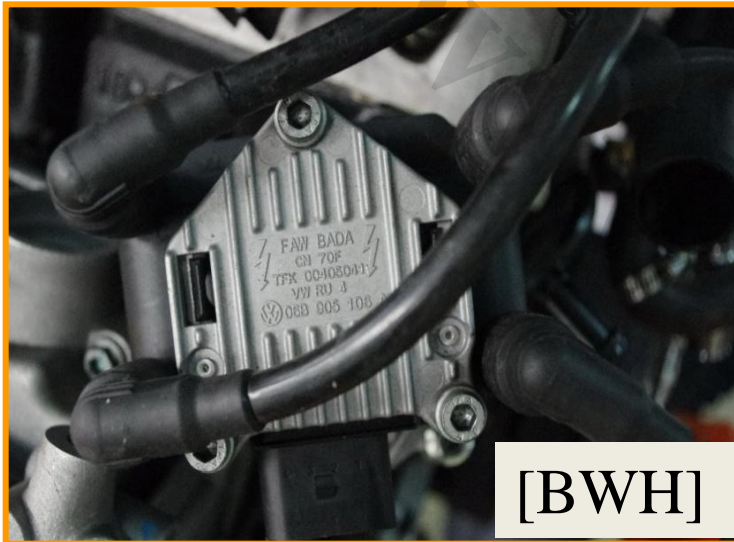

➤ Ignition (acting) order:

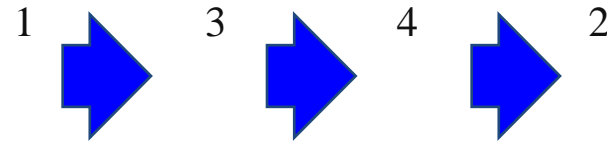

➤ **Location:** The ignition coil is located at upper cylinder head side (transmission side) of the engine

➤ Ignition coil transfers the low voltage power of primary winding into high-voltage power of secondary winding, discharge through the spark plug to produce spark to detonate the fuel air mixture in the cylinder

2.2 Ignition coil [BWH]

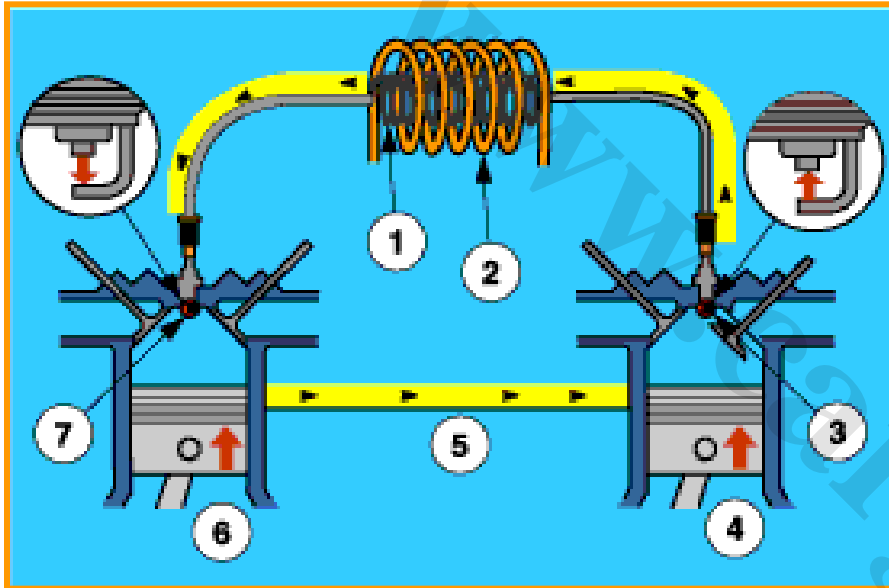

- Ignition coil consists of two primary windings, two secondary windings and iron core, shell and other components. When a ground channel connected to a primary winding, the primary winding will charge. Once the PCM primary winding resistance circuit cut-off, then charge termination, at the same time high voltage induced in the secondary winding, so that the spark plug discharge. Different with ignition coil with distributor, ignition coil secondary winding connect to a spark plug at each end, then the two spark plugs ignition at the same time. The two primary windings alternately to power up and power down. Corresponding to the two secondary windings alternately discharge

2. Ignition control

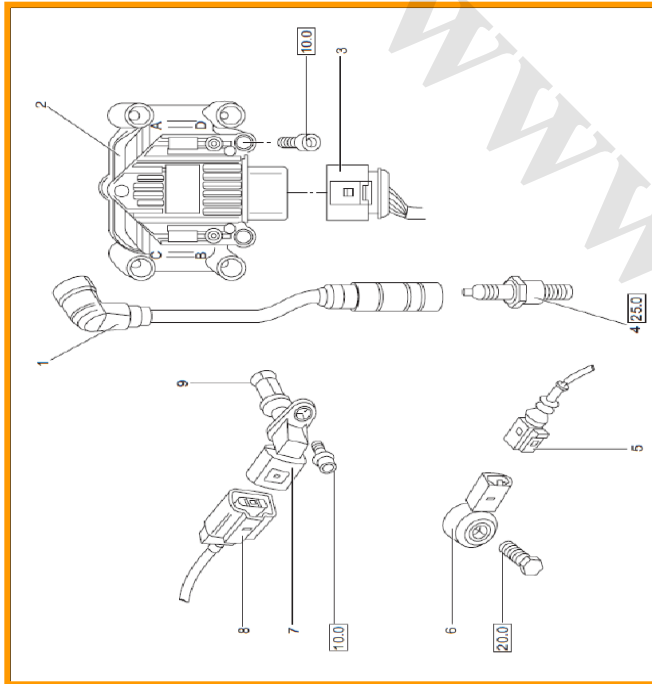

- Unplug high-voltage wire of the 1,4 -cylinder and measure the resistance value between the high-voltage connectors of Ignition coil, the resistance value between the two connectors is the resistance of the secondary coil , secondary coil resistance should be between 4 - 6KΩ

When installing the ignition wire , it should be installed correctly to Ignition coil:

A: cylinder 1 C: cylinder 3
B: cylinder 2 D: cylinder 4

High-voltage wire measurement:
4~8 KΩ

2.Ignition control

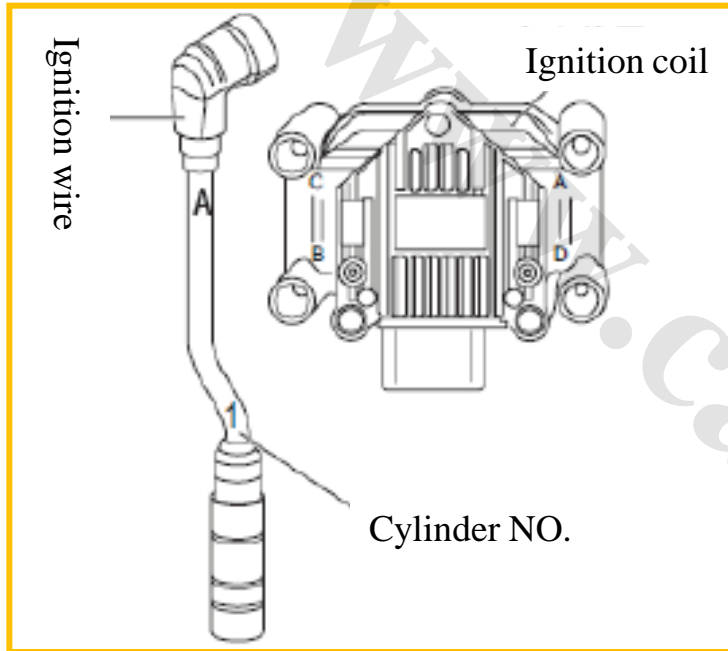

- A: Shield grounding wire
- B: 12V power supply
- C:PCM E17#
- D:PCM E01#

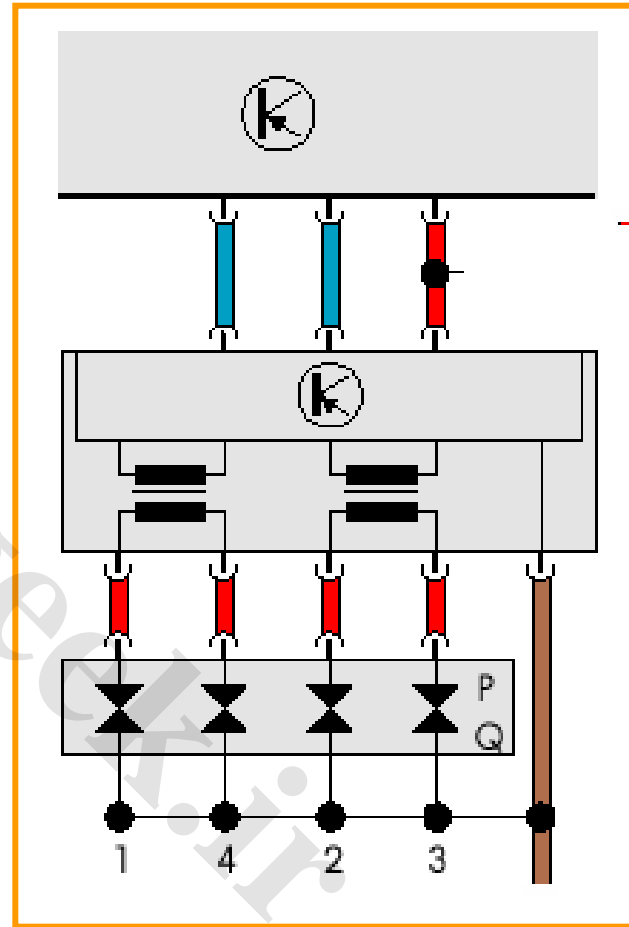

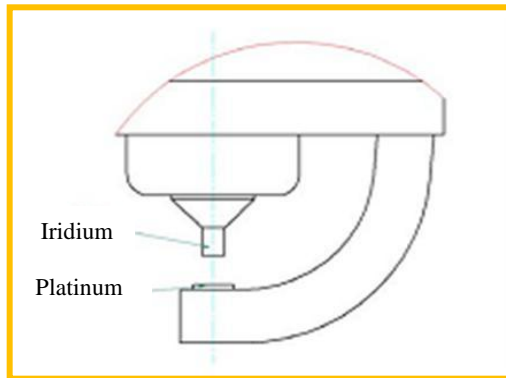

➤ Spark plug [BWH]

- Model: BKUR 6 ET -10
- Spark plug should be resistance type to reduce the ignition radio interference waves and protect the Ignition coil;
- Spark plug adjust clearance: 0.9 ~ 1.1mm ;
- Heating value : 6
- In order to ensure consistency of each cylinder ignition energy , spark plug opening clearance of each cylinder should be same.

3. Throttle and idle speed control

3.1 System overview

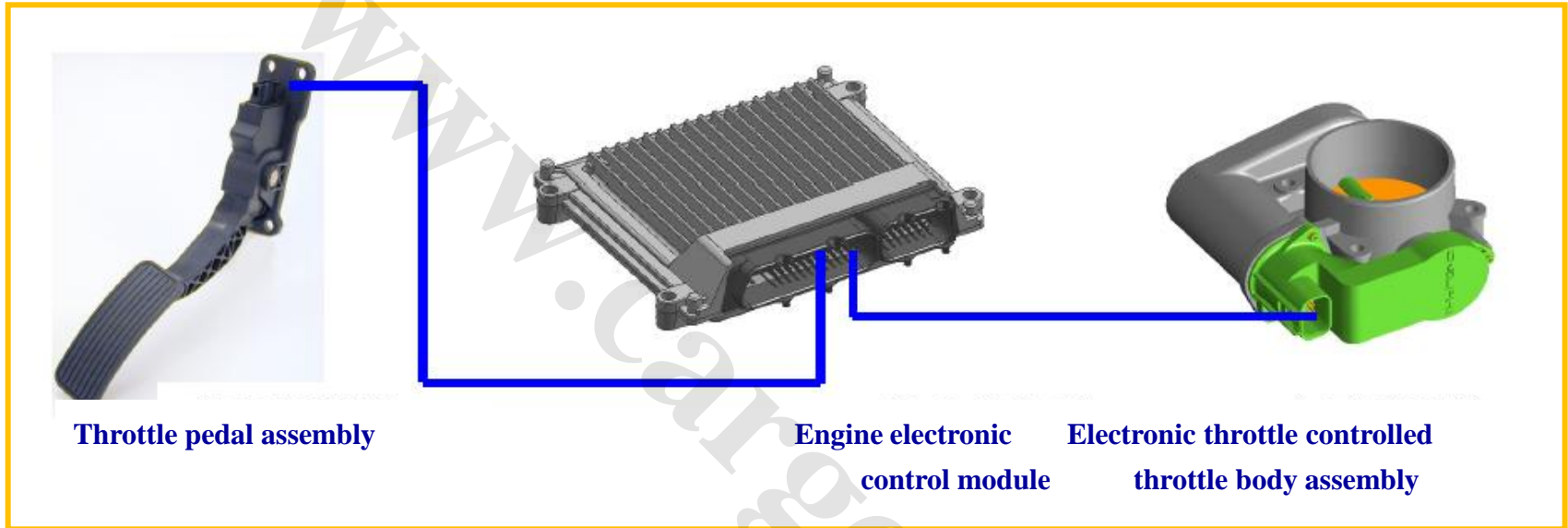

- Function: Electronic throttle can automatically open or close the throttle according to the wishes for drivers to tread the accelerator pedal, thus the engine can work in the corresponding conditions

3.2 Throttle body working principle

- **The electronic throttle is consisting of throttle body, drive motor and throttle position sensor, engine PCM instructions can make the drive motor action through drive mechanism, thus ensure the required throttle open angle for engine work.**
- Throttle position sensor (non-contact).
- Throttle drive motor is a miniature DC motor.
- The motor drives a set of special gear reduction mechanism and a two-way spring, when the system is powered down state, this mechanism can maintain opening of the throttle valves is greater than idle position, but don't exceed a secure location which ensure that vehicles continue to have the driving ability, if the engine electronic control system enters the fault mode, the electronic throttle valve plate will no longer action when steps acceleration pedal.
- Sum of the two signal pressure is equal to 5V.

3.3 Throttle drive motor structure description

Throttle drive motor is a miniature DC motor.

The motor drives a set of special gear reduction mechanism and a two-way spring, when the system is powered down state, this mechanism can maintain opening of the throttle valves is greater than idle position, but don't exceed a secure location which ensure that vehicles continue to have the driving ability, if the engine electronic control system enters the fault mode, the electronic throttle valve plate will no longer action when steps acceleration pedal.

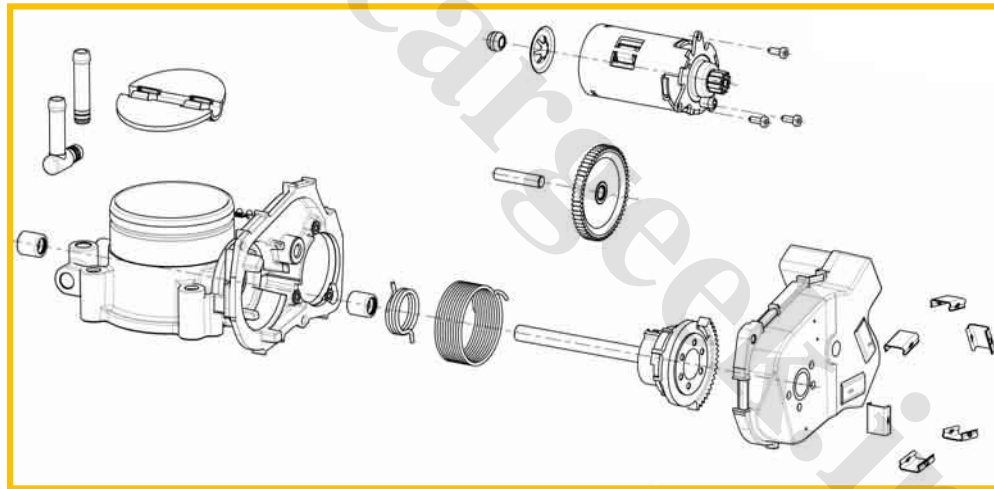

Disconnect connector of the electronic throttle, measure resistance value between terminal c and b with a multimeter, and the throttle drive motor properly . The measured resistance value is about 0.6Ω

3. Throttle and idle speed control

3.4 Throttle control motor [BWH]

Throttle control module consists of two throttle angle position sensor G187, G188 and throttle positioning motor G186 and other components, it supply necessary air for engine running.

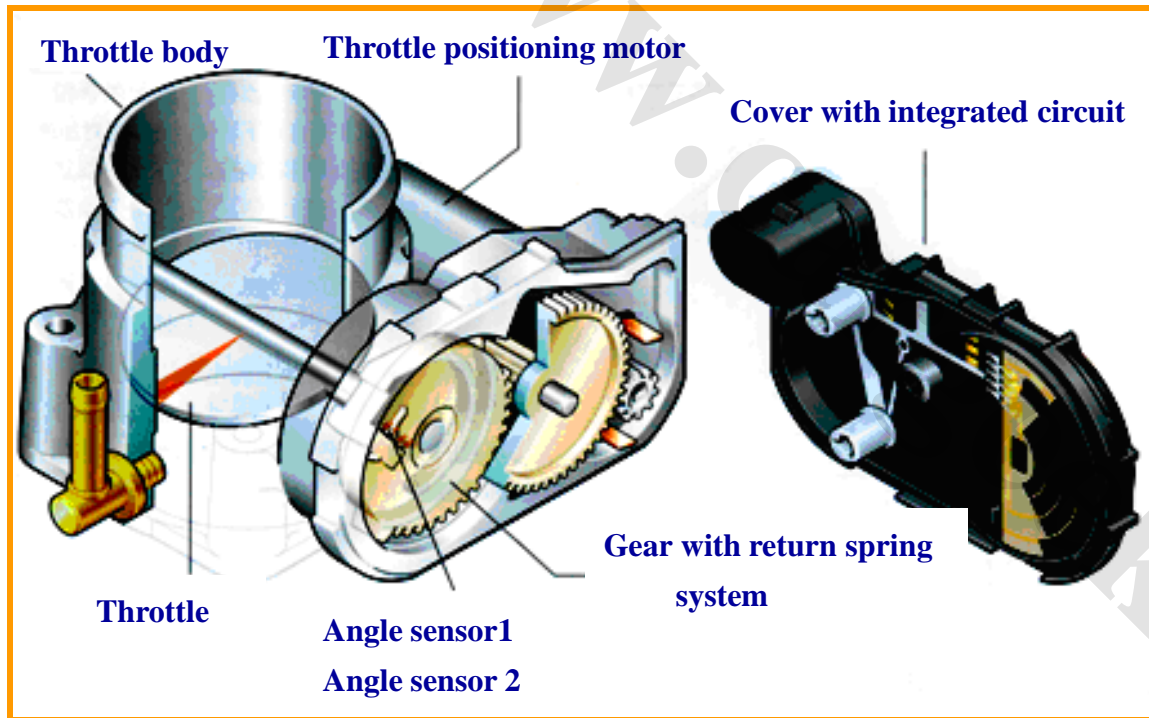

Throttle control module

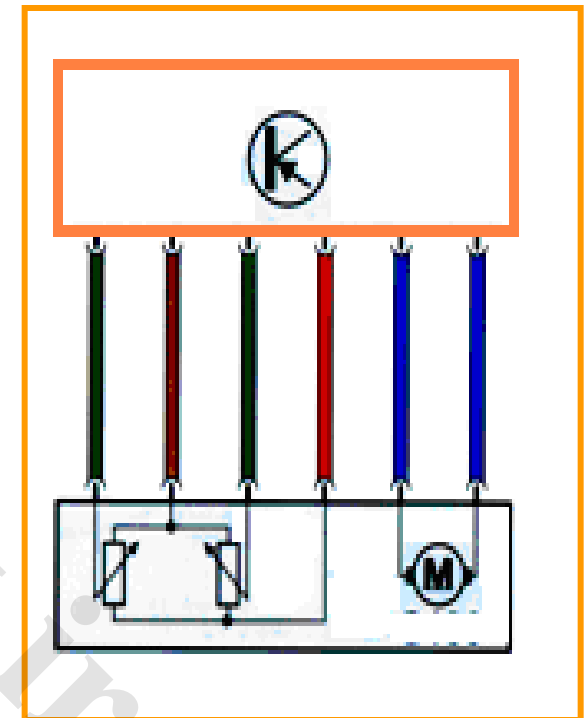

Throttle circuit diagram

3.5 Electronic throttle motor drive signal waveform 1

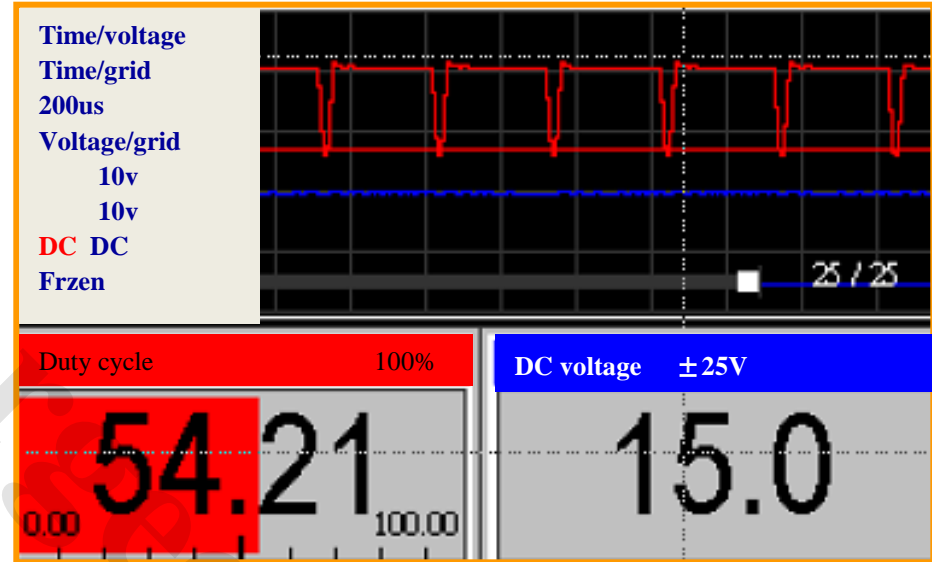
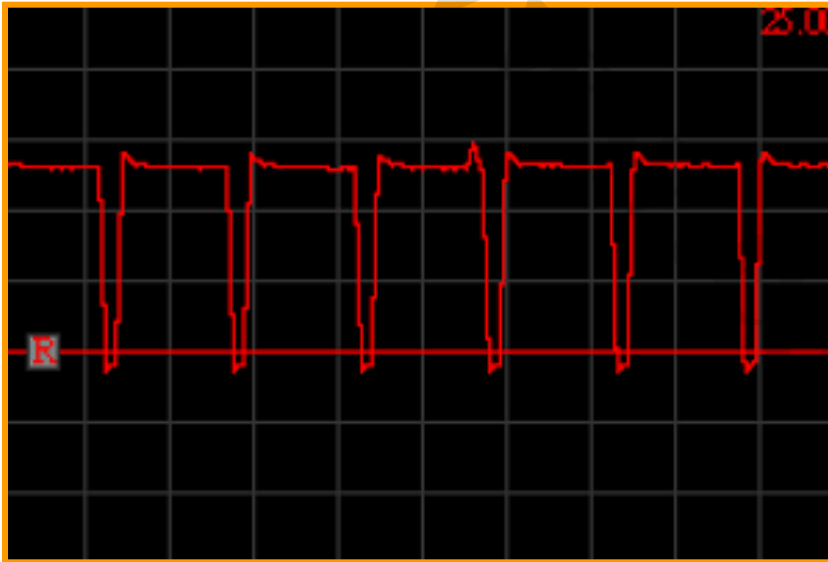

3.6 Electronic throttle failure emergency management

The electronic throttle body has two emergency modes:

① Emergency control when system can not control the engine power

- PCM will limit engine power output, the system will not be able to control open and close state of the throttle; throttle opening will automatically adjust to the default calibrated location.
 - PCM will close engine ignition output, the PCM internal fault exist at this time; system will not be able to control the engine output torque; throttle opening is automatically adjusted to zero close state; system will fully close the ignition control functions.

② System can not detect the driver's intent emergency control

- PCM will limit the engine power output. The system loses the function of auxiliary driver intent message judgment and detection; limited engine power control mode will be adopted to control engine power output, reduce the increment of engine power and speed increment to prevent engine damage; it will be automatically adjusted to engine idle speed working status at vehicle braking condition; throttle opening is automatically adjusted to the system default normal idle position
- The PCM will force the engine enter idle running state when system loses a valid driver's intention message.
- The PCM will force the engine enter idle running state, system will enter default state of idle speed control system.

4.1 Fuel system technical specification

Item		Technical Specification
injector	Type	High resistance
	Fuel supply type	Overhead supply
	Drive type	voltage
Pressure regulator control pressure (kPa{kgf/cm ² , psi})		About 380{3.87, 55.1}
Fuel pump type		Electric
Fuel tank volume (L)		64
Fuel type		Leadless (93 # or above)

It adopts no-return fuel supply system.

- no-return fuel supply system can reduce fuel evaporation in the Fuel tank.
- Pressure tank in the fuel tank can prevent fuel return from engine body. In this way , it can reduce fuel evaporation amount caused by temperature rise.
- Pressure regulator locates at fuel pump assembly in the fuel tank.

4. Fuel supply and injection

4.2 Fuel system structure chart

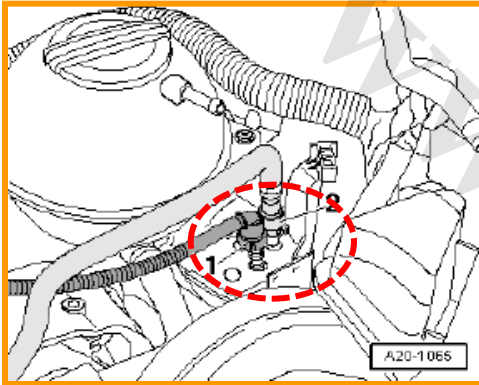

Quick release connector

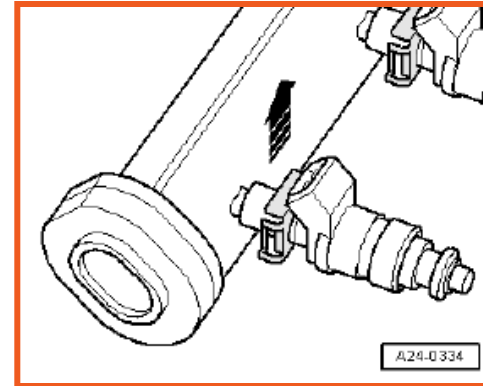

Fuel Injector

Fuel pump relay

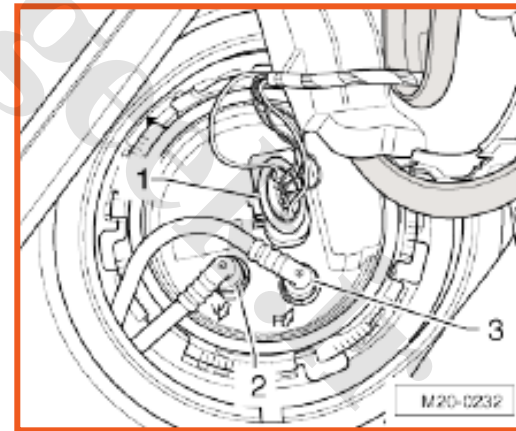
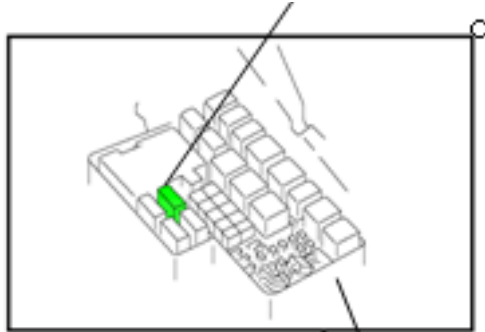

2 Black fuel inlet pipe

3 Blue fuel return pipe

4. Fuel supply and injection

Fuel tank side

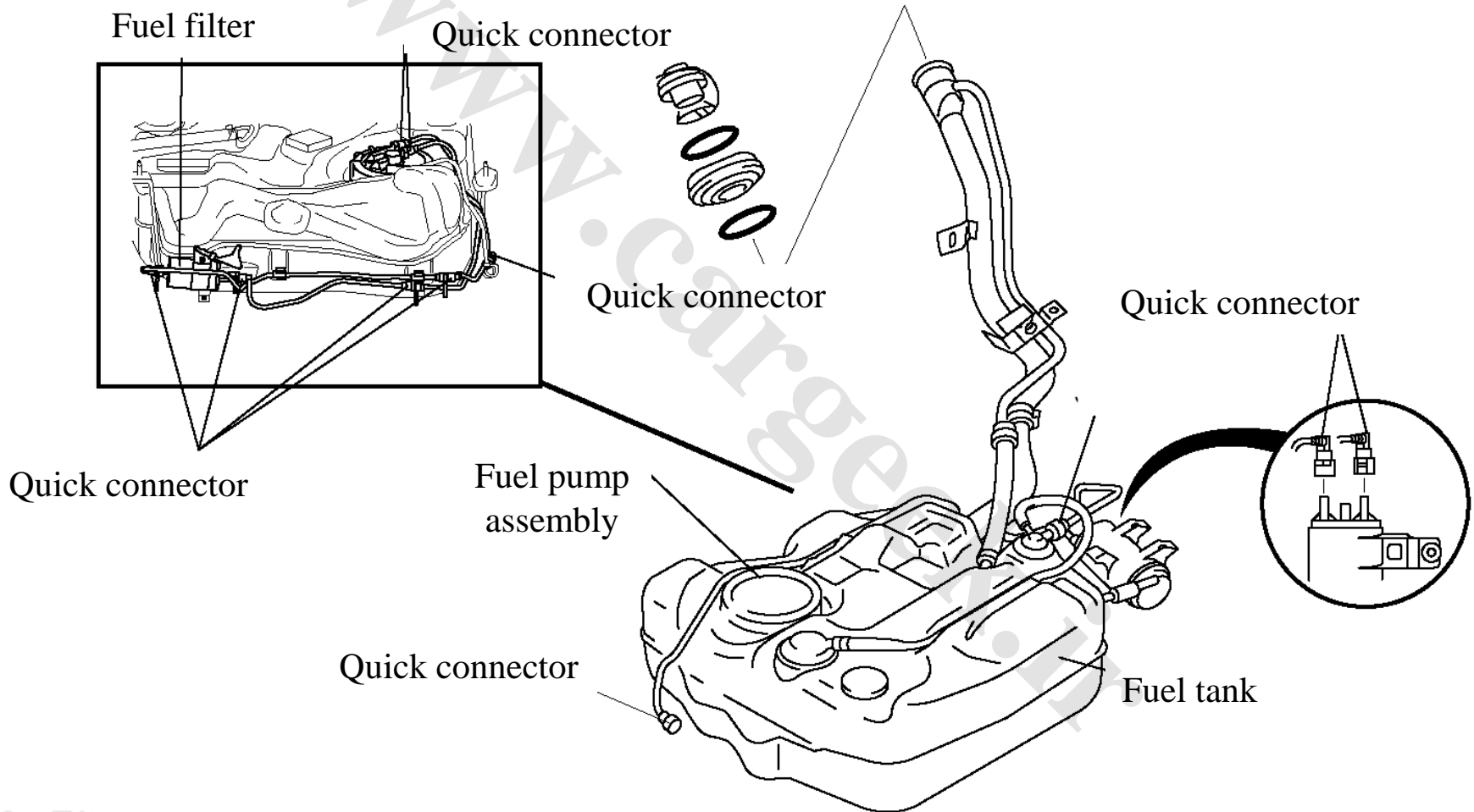

4. Fuel supply and injection

4.3 Fuel system flow diagram

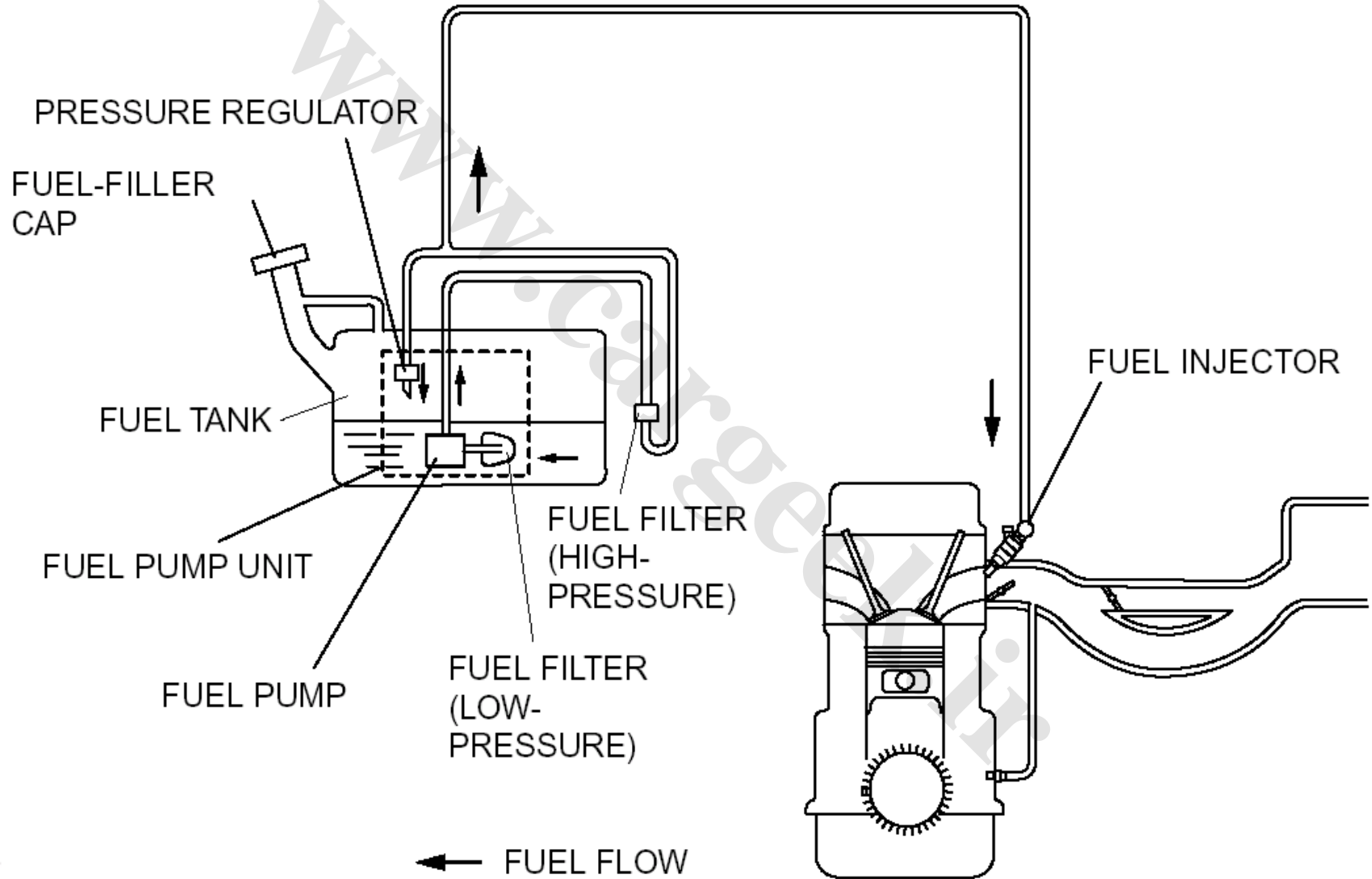

4.4 Fuel pump structure

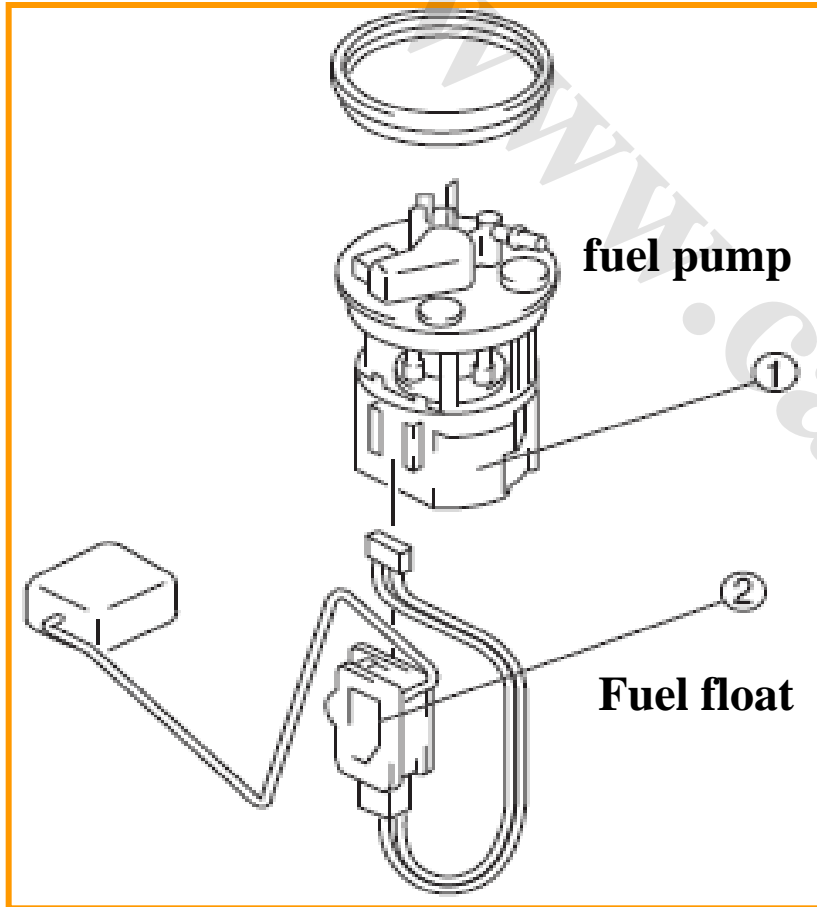

- Fuel pump component check
- fuel pump maintain pressure[LF, L3 , BWH]
- Large than 200 kPa{2.0 kgf/cm², 29 psi }

4.4.1 Fuel injector

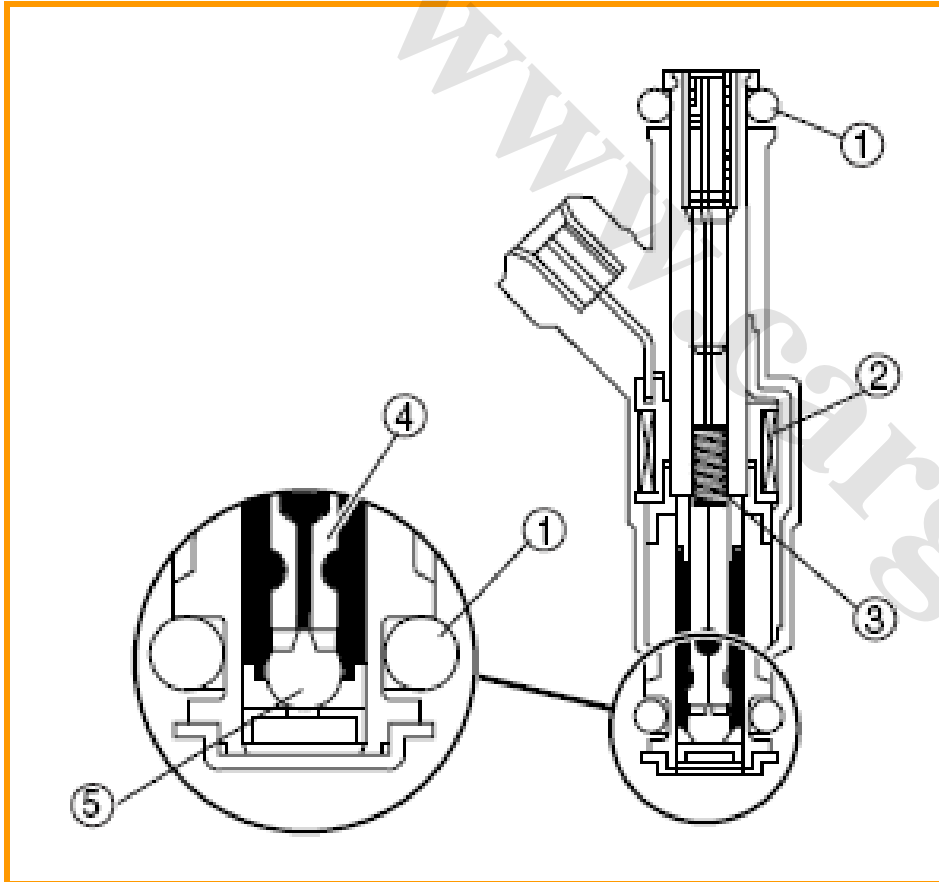

1	O - ring
2	Coil
3	Spring
4	Needle valve
5	Ball bearing

4.4.2 Component structure and working principle

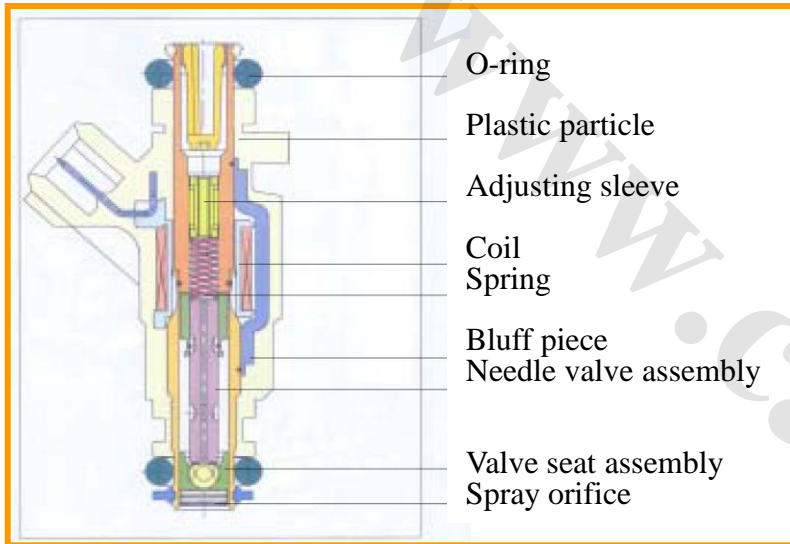

- Fuel injector is electromagnetically controlled injector. Return spring within the shell compress the valve needle in the seat and seal the mouth.
- During injection process, electronic controller gives a control signal to power the electromagnetic coil which produces a magnetic field to overcome pressure of the return spring, needle valve gravity, and friction to lift the needle valve and inject fuel. As the needle valve only has rising and falling states, the needle lift can not be adjusted, as long as the injector import and export of pressure difference is constant, then the fuel injection quantities depends only on the needle valve open time or open the electrical pulse width. Needle valve lift does not exceed 0.1mm

4.4.3 Injector check

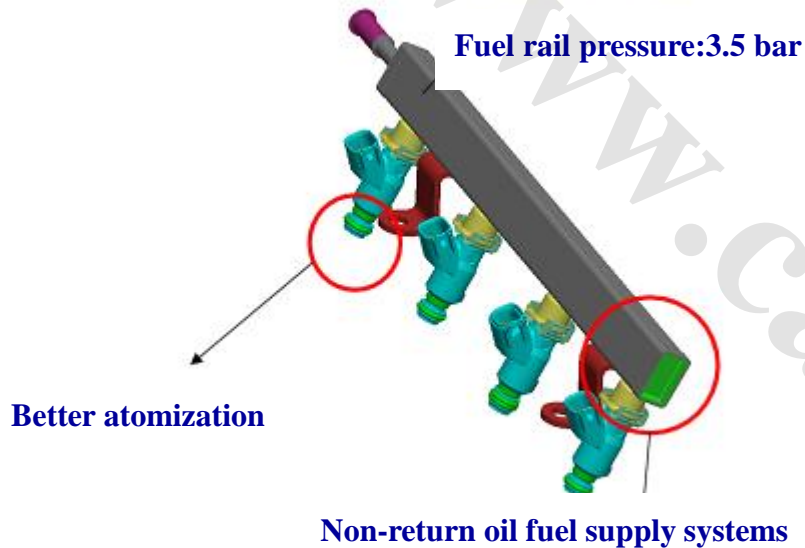

➤ Injector check [LF, L3]

Resistance check

1. Turn ignition switch to the LOCK position.
2. Disconnect the battery negative cable.
3. Disconnect the injector connector.
4. Use a resistance meter to measure resistance of the injector.

If not in conformity, please replace injector.

If consistent with the provisions, but “test run” fails, then perform “open / short circuit” check. Check for open or short circuit.

- Injector resistor
- 11.4-12.6 ohms [20 ° C {68 ° F}]

4.4.4 Injector waveform

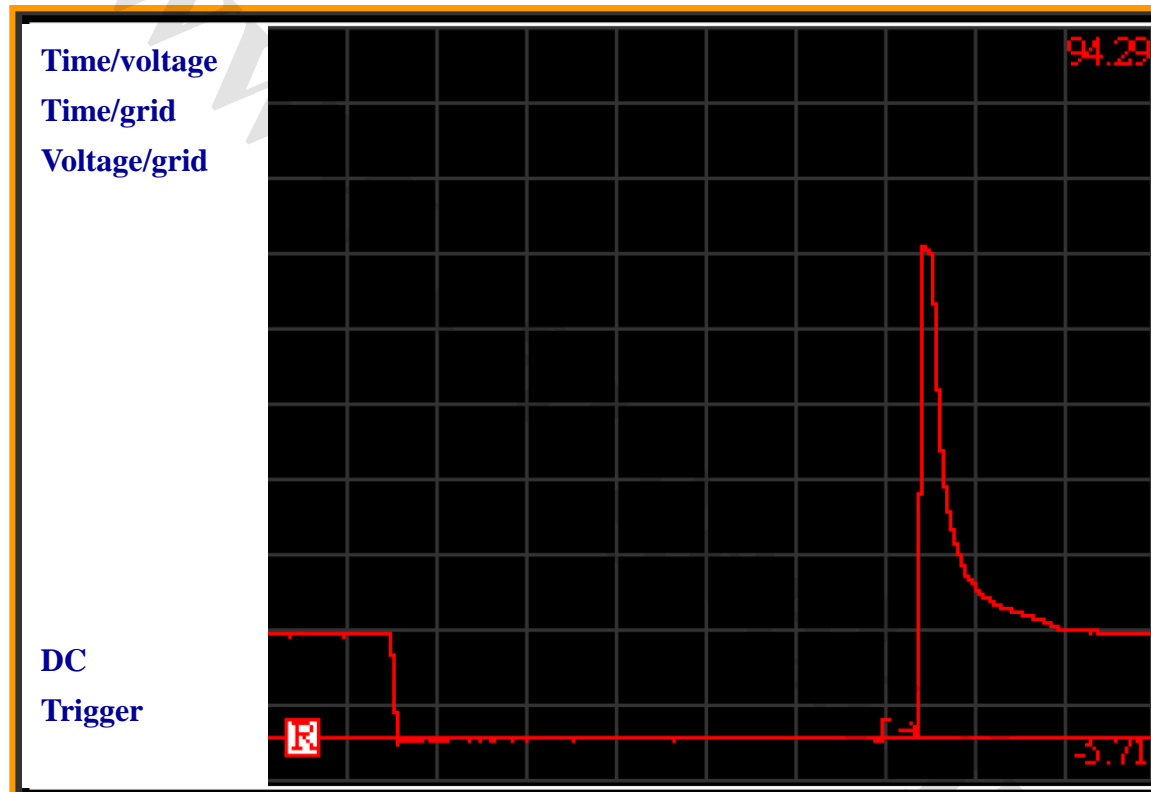

4.4.5 Circuit diagram of the injector

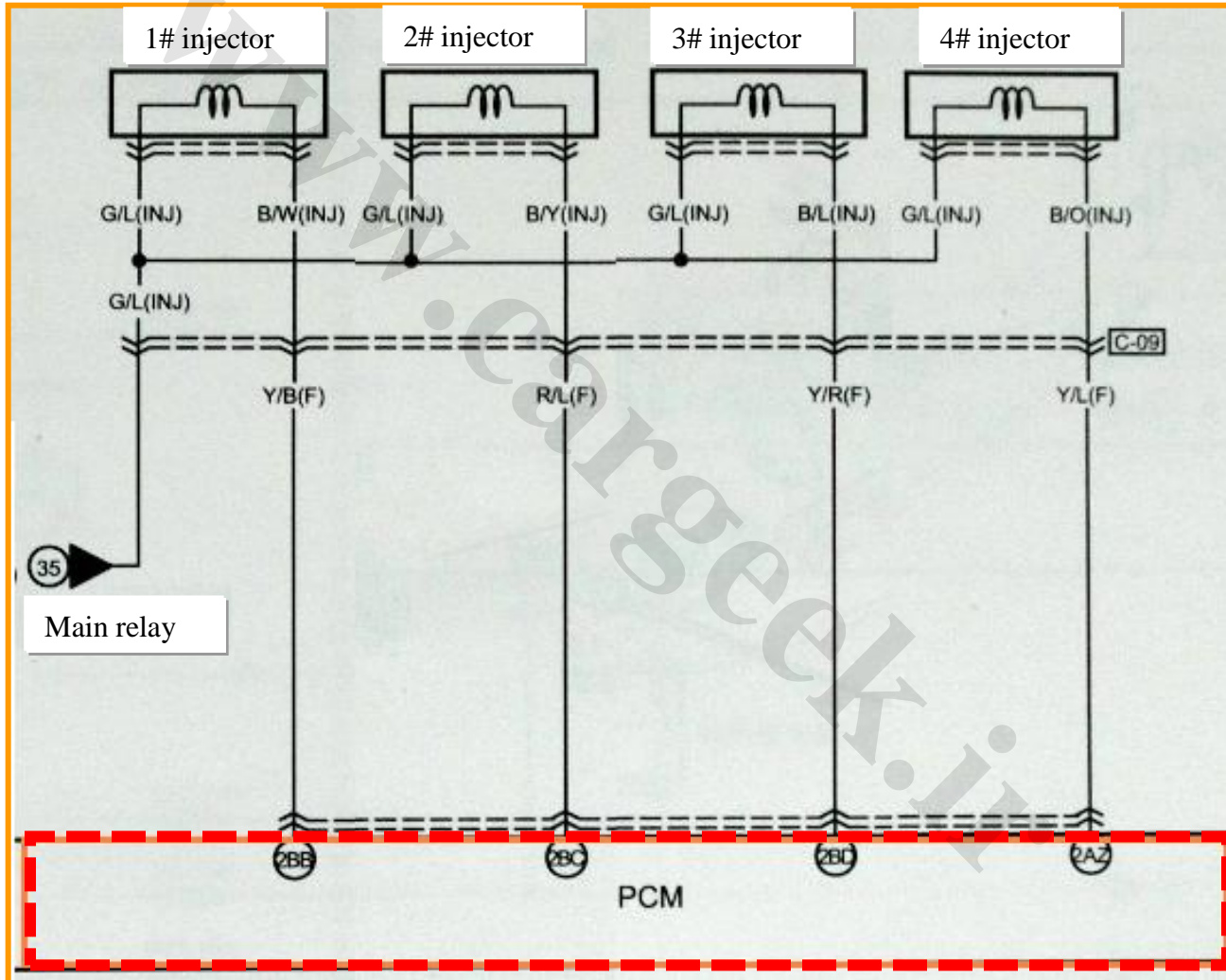

4.4.6 Fuel injector cleaning

Fuel injector cleaning tester

Non-dismantling
cleaning machine



Injection degree: 25°

Before
cleaning



After
cleaning



Poor atomization

4. Fuel supply and injection

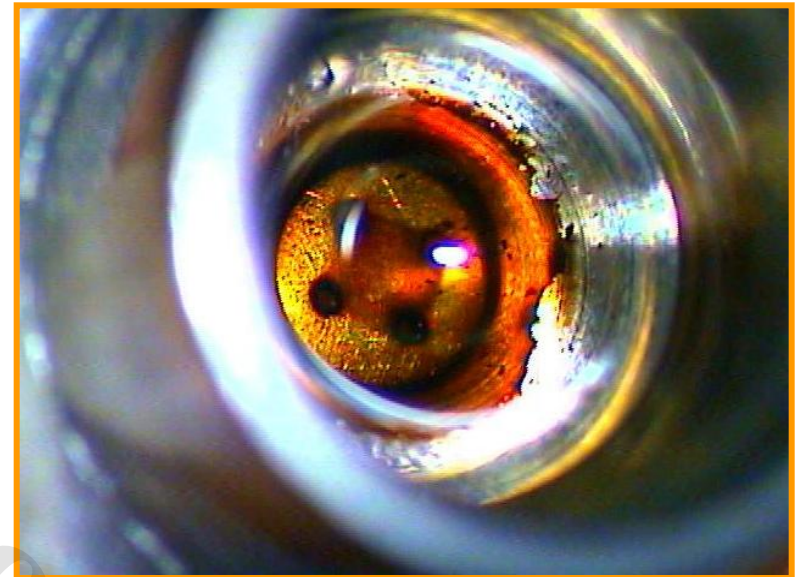
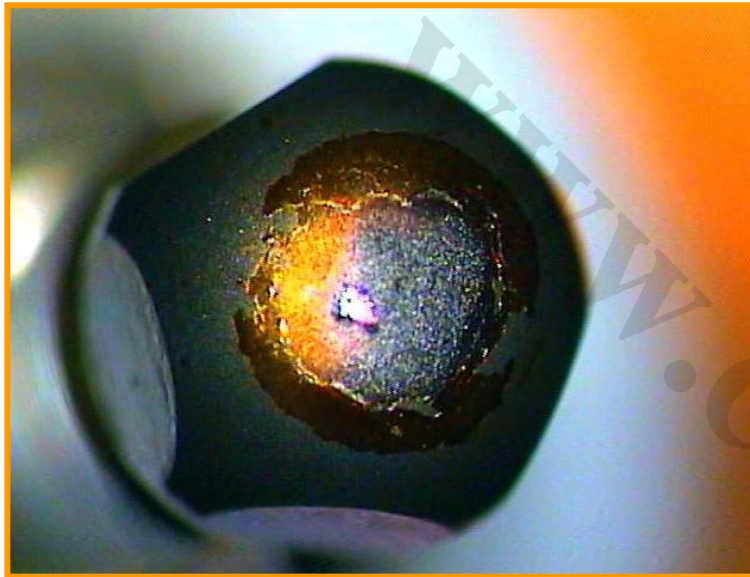

Fault phenomenon: poor idle and acceleration , can not start (difficult to start) etc.

General failure reasons : gel accumulation failure within in the injector due to lack of maintenance .

Simple measuring method: (Remove the connectors) switch the digital multimeter to the Ohm range , connect the poles with two pins of injector respectively, the nominal resistance at 20 ° C should be 12Ω .

Recommendation: use special injector cleaning analytical instrument to clean the injector regularly.

www.cargeek.ir
Thank you!

奔腾 BESTURN



Technical Training of BESTURN B50



Manual transmission structure

奔腾 BESTURN

Suitable post: Technical Director

Internal data, please do not disclose it externally

Curriculum Goals

- Understand basic structure of the manual clutch
- Check the real object to be familiar with the structure of manual transmission
- Check the real object to learn about the power transfer process of transmission

Contents



1. B50 clutch components

2. MQ200 manual transmission

1.B50 clutch components

1.2 Clutch separation mechanism

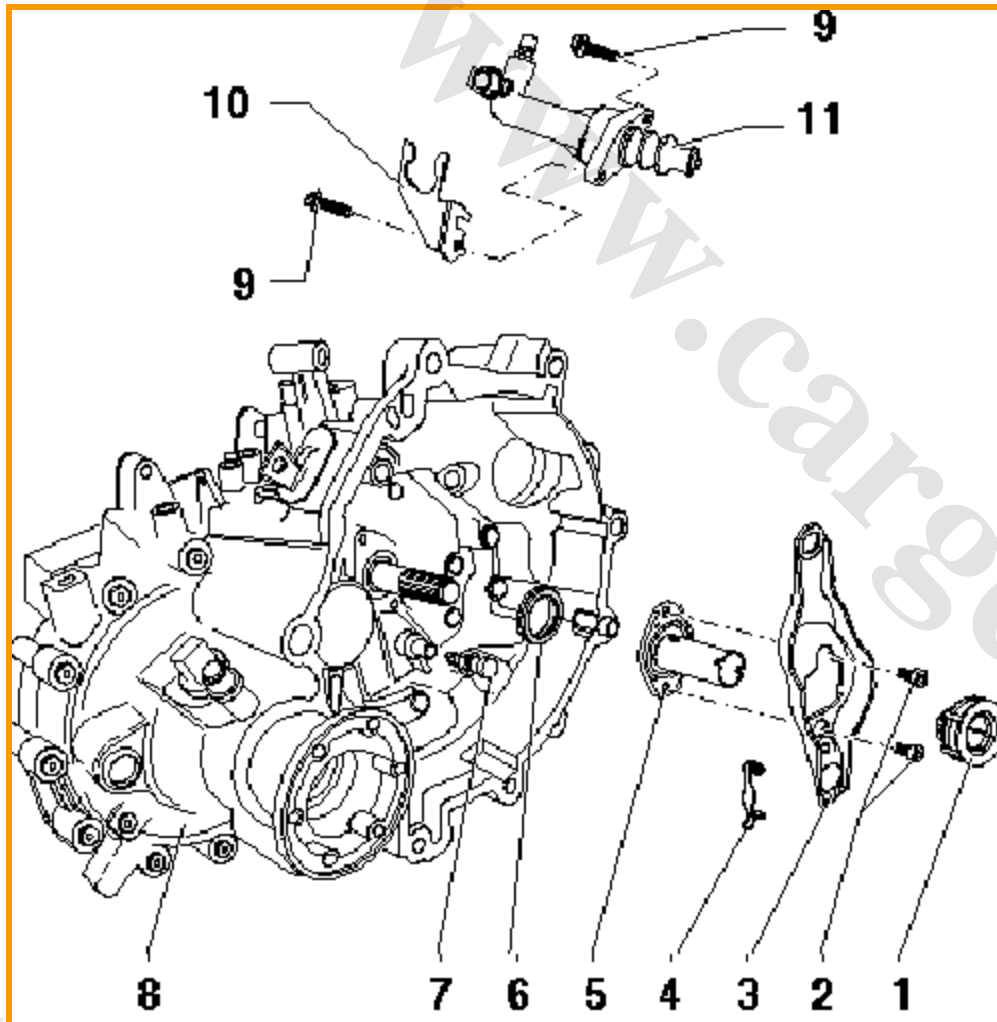

- 1 – Release bearing
- 2 - Bolt, 5 Nm, and continues to rotate 90 °
- 3 - Clutch release lever
- 4 - Retaining spring
- 5 - Guide sleeve
- 6 - Drive shaft sealing ring
- 7 – Ball-type pin, 20 Nm
- 8 – Transmission
- 9 - Hex bolts, 20 Nm
- 10 – Bracket
- 11 - Slave cylinder

2.1 MQ200 Basic features

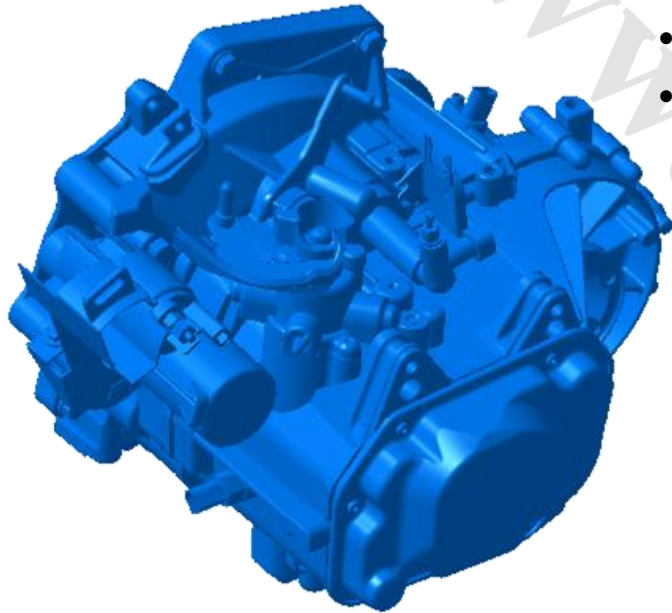

- High load-carrying capacity: with 200N.m maximum carrying capacity
- Reasonable and compact structure
- Lightweight technology
- Easy to manipulate: three-dimensional synchronizers reduce the shift power by 50% and gearshift easily

Manual transmission

Engine	1.6litre-74kilowatt
Transmission ratio: Z2:Z1	main retarder 72:17=4.235
Gear one	34:9=3.778
Gear two	36:17=2.119
Gear three	34:25=1.360
Gear four	35:34=1.029
Gear five	36:43=0.837
Gear six	-
Reverse gear	18:9*36:20=3.600
Speedometer	13:22=0.591

2.2 Input shaft components

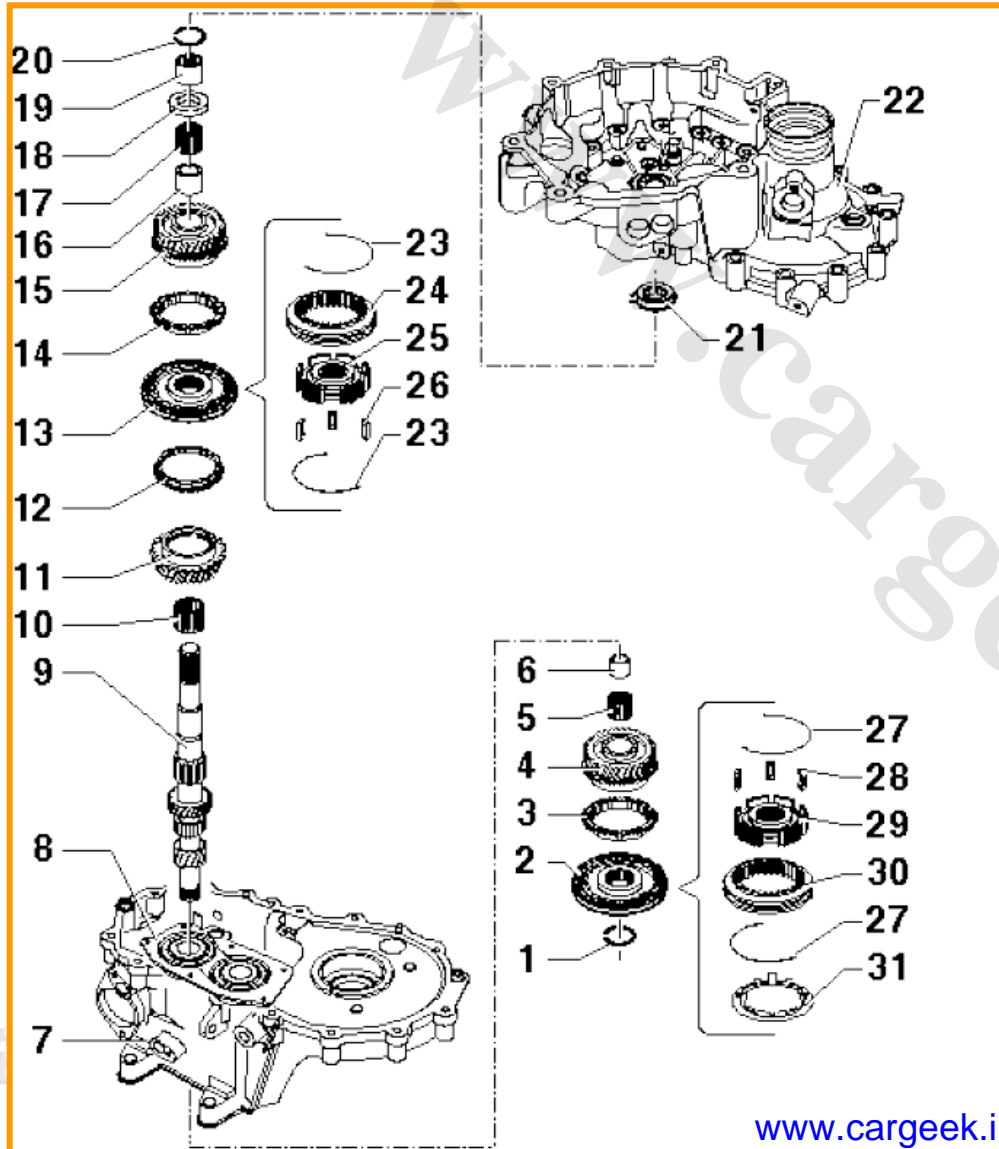

- | | |
|--|--------------------------------------|
| 1 – Clasp | 16 – Inner ring |
| 2 – Sliding sleeve and five-speed synchronous body | 17 - Needle roller bearings |
| 3 – fifth gear synchronizer ring | 18 - Thrust washer |
| 4 – Fifth shift gear | 19 - Roller bearing inner ring |
| 5 - Needle roller bearings | 20 – Clasp |
| 6 – Inner ring | 21 - Roller Bearing |
| 7 – Transmission case | 22 - Clutch case |
| 8 – Bearing bracket and radial ball bearings | 23 – Spring |
| 9 - Input shaft | 24 – 3-4 gear sliding sleeve |
| 10 - Needle roller bearings | 25 – 3-4 gear synchronization body |
| 11 – Third gear synchronizer ring | 26 – Closing piece (3) |
| 12 - Third gear synchronizer ring | 27 – Spring |
| 13 - Sliding sleeve and 3-4 gear synchronous body | 28 - Closing piece (3) |
| 14 – Fourth gear synchronizer ring | 29 – fifth gear synchronization body |
| 15 – Fourth gear | 30 - fifth gear sliding sleeve |
| | 31 - Limit ring |

2.3 Output shaft components

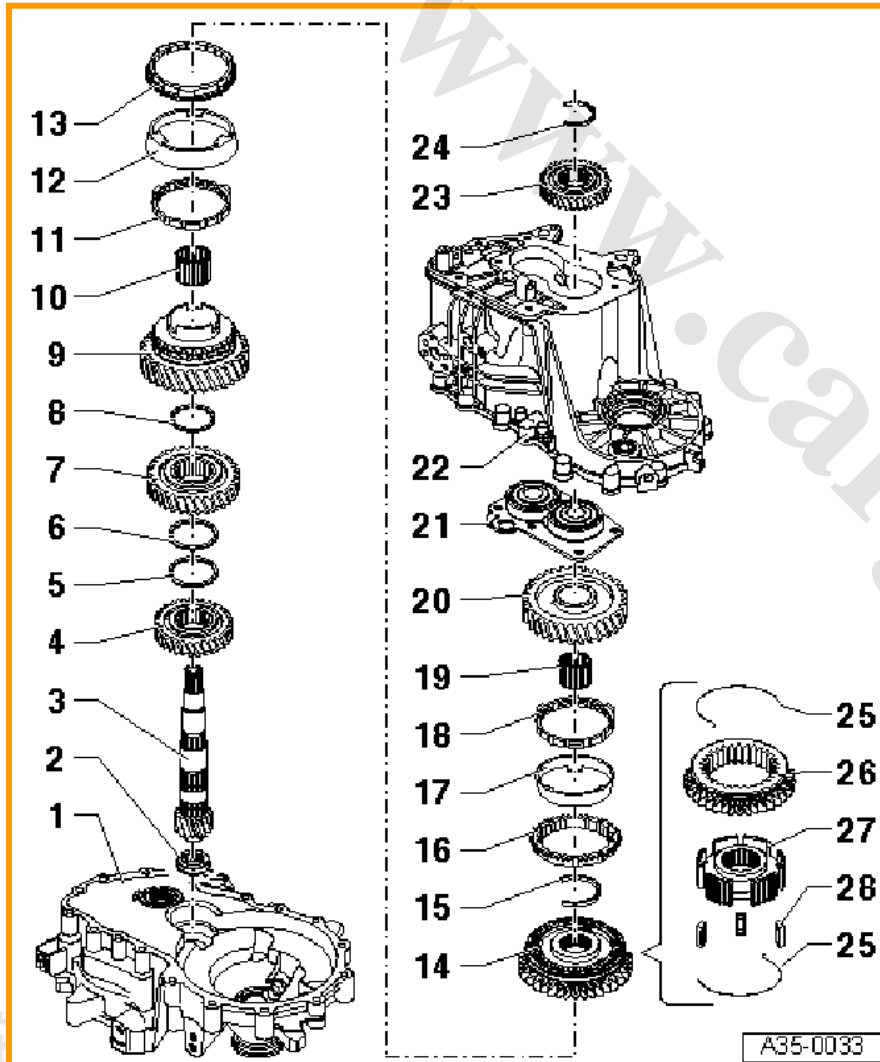

- | | |
|---|---|
| 1 - Clutch case | 15 - Clasp |
| 2 - Roller bearings | 16 - First gear synchronizing rings |
| 3 - Output shaft | 17- Outer ring of first gear |
| 4 - Fourth gear | 18- Inner ring of the first ring |
| 5 - Clasp | 19 - Needle roller bearings |
| 6 - Clasp | 20 - 1st gear |
| 7 - Third gear | 21 - Bearing bracket and radial ball bearings |
| 8 - Clasp | 22 - Transmission housing |
| 9 - Second gear | 23 - five-speed gears |
| 10 - Needle Roller Bearings | 24 - Clasp |
| 11- Inner ring of second gear | 25 - Spring |
| 12- Outer ring of second gear | 26 - Sliding sleeve |
| 13 - Second gear synchronous ring | 27 - Synchronized body |
| 14 - Sliding sleeve and 1-2 gear synchronous body | 28 - Closing piece (3) |

A95-0033

2.4 Differential structure

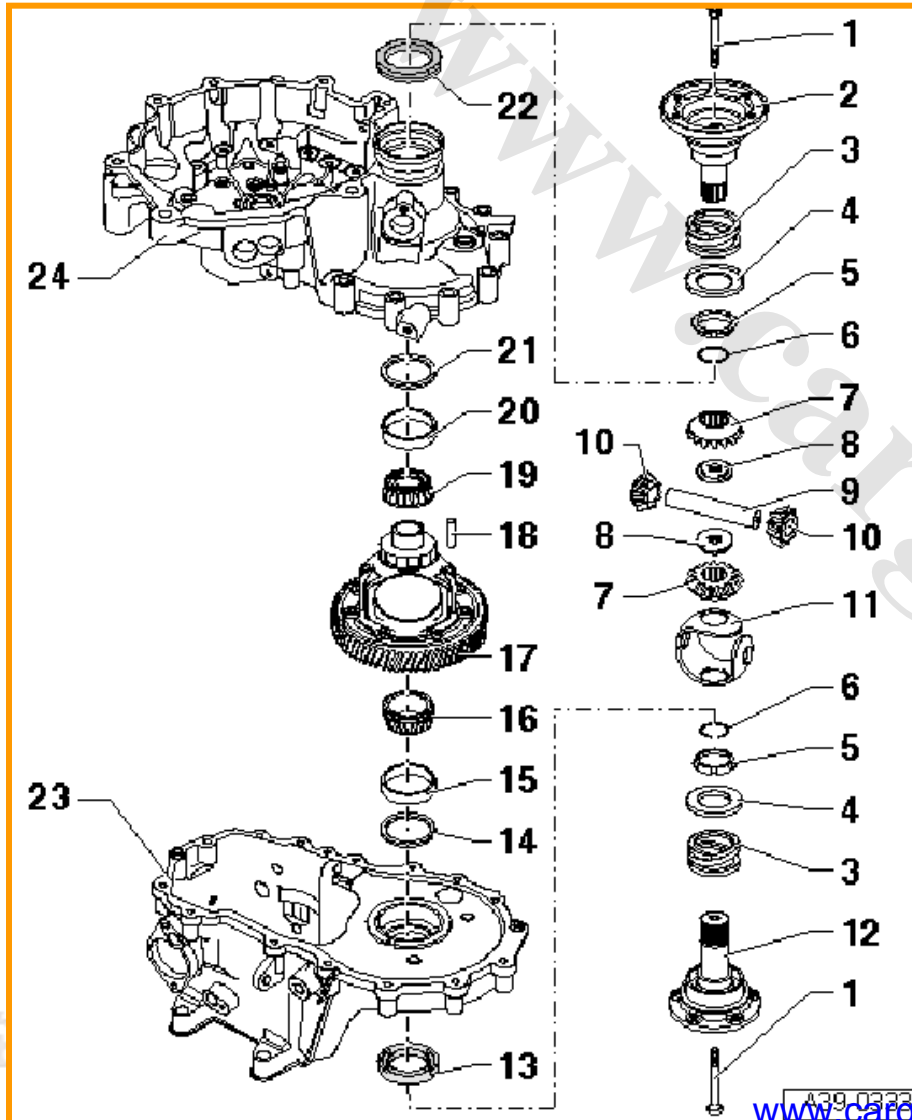

- 1 - taper bolt, 25 Nm
- 2 - Right flange shaft
- 3 - Flange shaft pressure spring
- 4 - Thrust washer
- 5 - Taper ring
- 6 - Clasp
- 7 - Differential planets gear
- 8 - Thread piece
- 9 - Differential bevel gear axis
- 10 - Differential asteroid gear
- 11 - Combined thrust washers
- 12 - Left flange shaft
- 13 - Left flange shaft seal ring
- 14 - Adjusting shim S1
- 15 - Tapered roller bearing outer ring
- 16 - Tapered roller bearing inner ring
- 17 - Differential case
- 18 - Cotter pin
- 19 - Tapered roller bearing inner ring
- 20 - Tapered roller bearing outer ring
- 21 - Adjusting shim S2
- 22 - Right flange shaft seal ring
- 23 - Gearbox case
- 24 - Clutch case

www.cargeek.ir
Thank you!

奔腾 BESTURN

Technical Training of BESTURN B50

Automatic transmission structure

奔腾 BESTURN

Suitable post: Technical Director

Internal data, please do not disclose it externally

Curriculum Goals

- Preliminary familiar with structure of the automatic transmission
- Preliminary identify all system components and their role
- Describe the power flow and the hydraulic circuit of each gear
- Understanding position and role of the various sensors and actuators
- Perform control system fault diagnosis

Contents

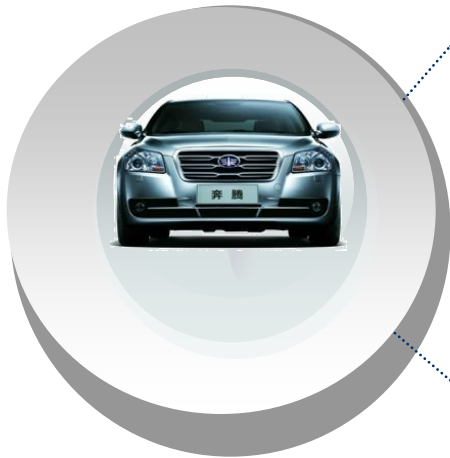

1. AQ200 Transmission structure

2. B50 Automatic transmission control

1.1 Intelligent 6-speed tiptronic automatic transmission

6 -speed
Weight:84 kgs.

Simple and compact
transverse transmission

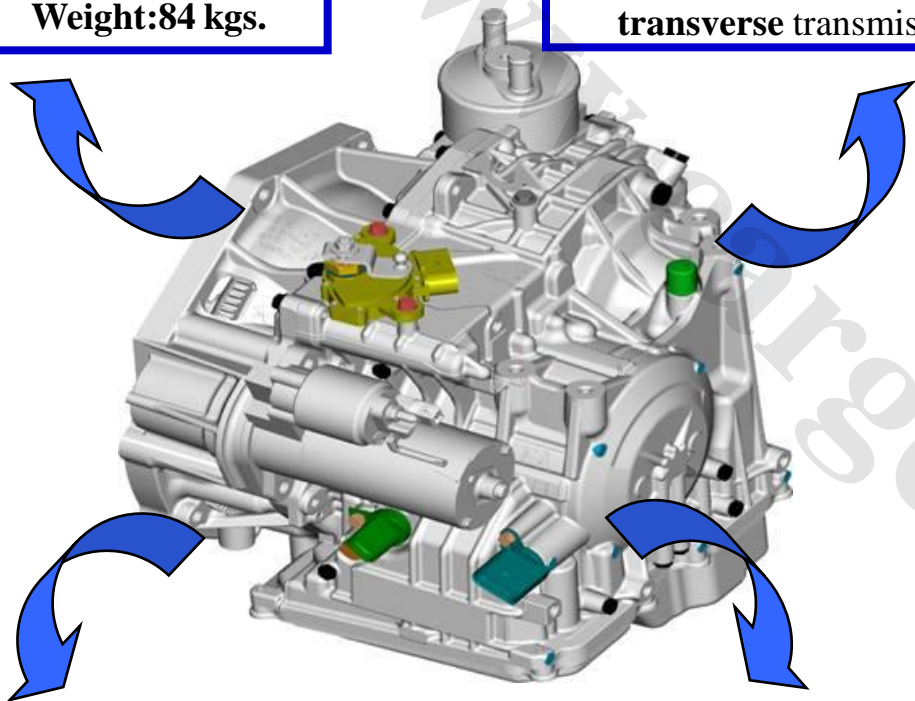

Gearbox oil filling : 7 litres

Economic gear: "D"
Sport gear: "S" Tiptronic



- Driving control mode
- Automatic mode, manual mode, sports mode

1.2 Technical Specifications



Torque volume	200N.m	
Total length	349.5mm	
Gross weight	83.5kg(include gear fluid)	
Maximum input speed	6500rpm	
Minimum idle speed	700rpm (D gear)	
Gear ratio (200N.m spec)	1st gear ratio	4.148
	2nd gear ratio	2.370
	3rd gear ratio	1.556
	4th gear ratio	1.155
	5th gear ratio	0.859
	6th gear ratio	0.686
	Reverse gear ratio	3.394

1.AQ200 transmission structure

www.CarGeek.ir





Technical Specifications

A/T type		AQ200 6-Speed	
Vehicle		BESTURN B50	
A/T part number (AW part number)		FA04 03000 (30510-TFB036)	
TCU part number (TCU part number)		FA04-189E1 (89530-TFB300)	
Manual gearshift control		0	
Engine type		BWH1. 6L	
D gear stalling speed (r/min)		3080 (Engine torque=145N.m)	
Gear ration	1st gear ratio		4. 148
	2nd gear ratio		2. 370
	3rd gear ratio		1. 556
	4th gear ratio		1. 155
	5th gear ratio		0. 859
	6th gear ratio		0. 686
	Reverse gear ratio		3. 394
	Differential gear ration		4. 315
Clutch Brake One-way clutch	Clutch	C1	1 flange, 4 discs, 4 pieces
		C2	1 flange, 3 discs, 3 pieces
		C3	1 flange, 3 discs, 3 pieces
	Brake	B1	2 flange, 3 discs, 4 pieces
		B2	2 flange, 5 discs, 4 pieces

奔腾 BES

www.cargeek.ir

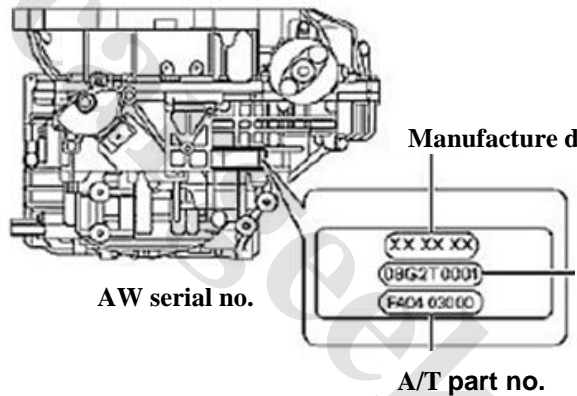
1.AQ200 transmission structure

Two solenoids	Shift electromagnetic valve		2 electromagnetic valves (S1,S2)
	Linear electromagnetic valve		6 electromagnetic valves (SLC1,SLC2,SLC3,SLB1,SLT,SLU)
ATF (Life-long maintenance-free)	AW		ESSO JWS-3309
	FCC		JWS-3309
Pipeline pressure(Kpa)	Idle speed	D	337-437
		R	508-643
	Stalling	D	1295-1500
		R	1875-2106
A/T serial no.	 <p>AW serial no.</p> <p>Manufacture date</p> <p>Serial no.</p> <p>A/T part no.</p>		
TCU serial no.	 <p>Serial no.</p>		

1.AQ200 transmission structure

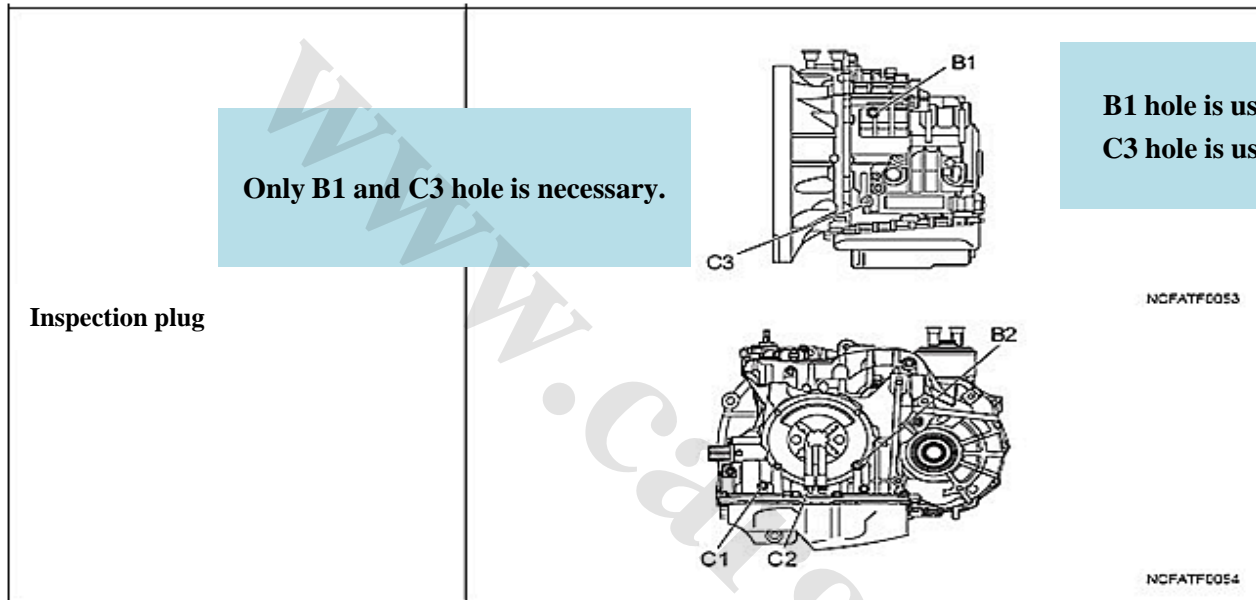

0 8 G 2 T 0 0 0 0 1

1 2 3 4 5 6 7 8 9 10

Detailed description

1-2	Manufacture year 08 represents year 2008											
3	Manufacture month											
	A	B	C	D	E	F	G	H	I	J	K	L
	Jan	Feb	Mar	April	May	June	July	Aug	Sep	Oct	Nov	Dec
4-5	A/T type											
	2T	TF-61SN										
6-10	Manufacture serial no. of the current month 00001											

1.3.1 Gear operating mechanism

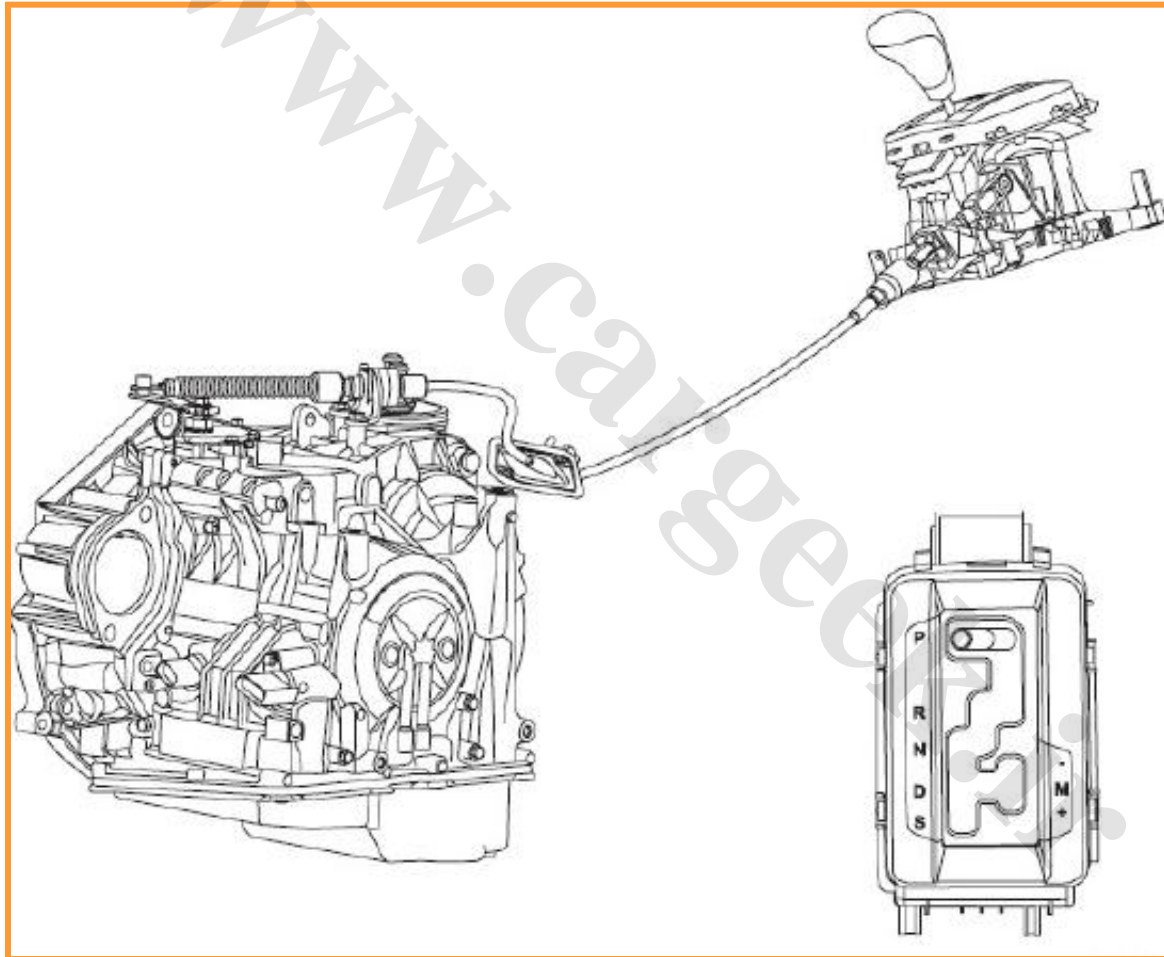

1.3.2 Shift cable installation

1. Place the shift lever in P gear
- 2 Turn the ignition key to ON position
- 3 Operate shift cable until the instrument cluster display gear P
4. If it is difficult to install as a result of shift cable length, and then pull out the shift lock piece according to direction of the arrow, pull out the locking pieces and move flexible joints to adjust the shift cable to proper length.

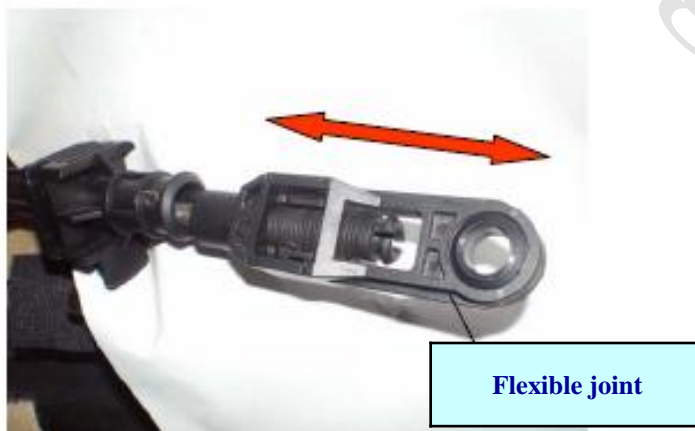
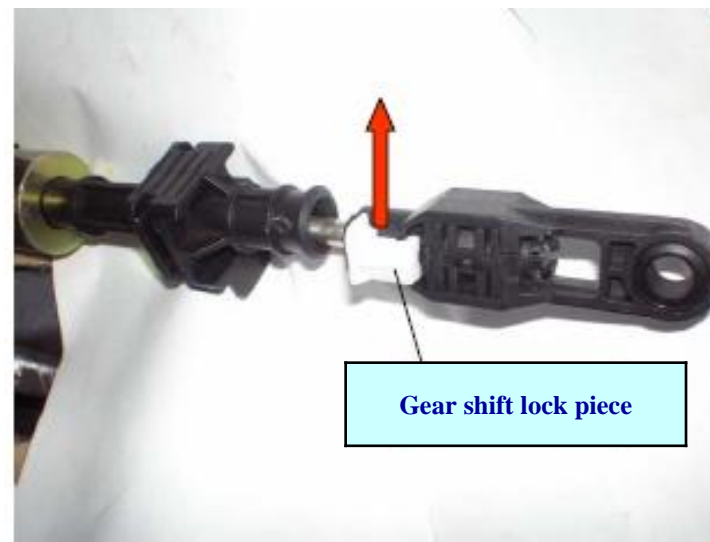

1.4.1 ATF fill and oil level check

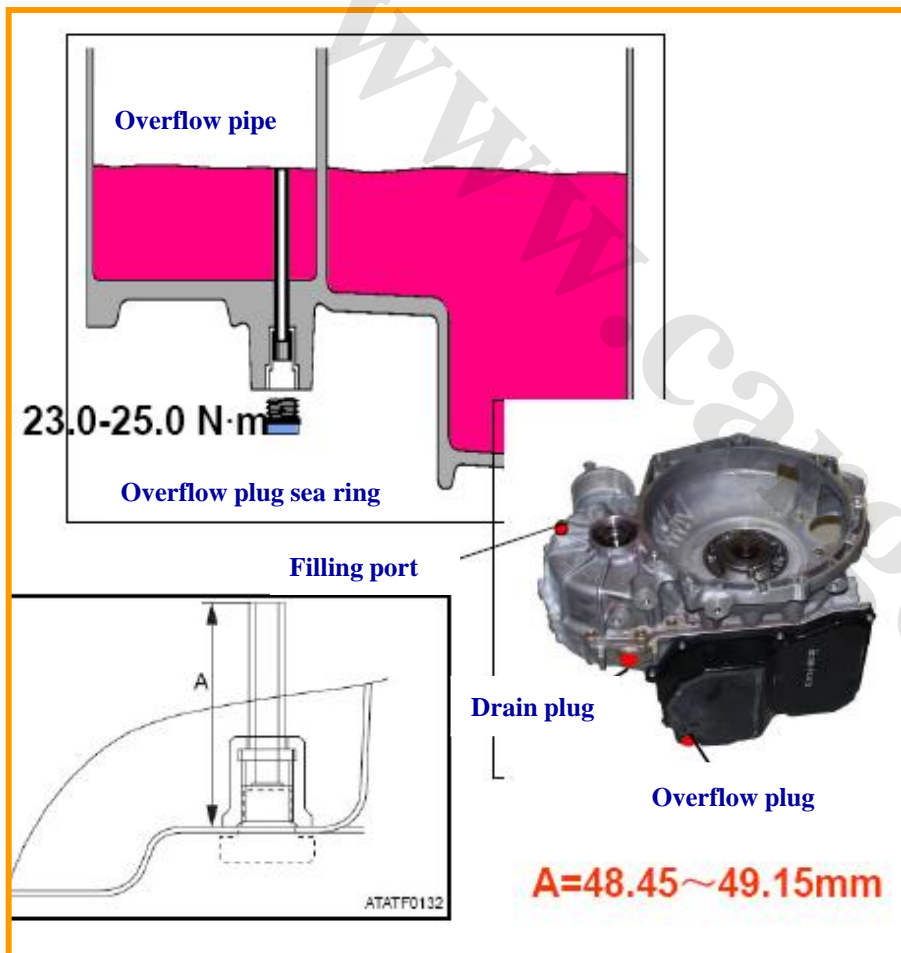

1. P gear, with engine off
2. Fill with ATF until overflow
3. Starting the engine and fill with ATF until overflow
4. Cooling ATF to 35 degrees below
5. Tread the brake pedal, perform gearshift between P gear and D gear twice, stay for more than two seconds at each gear and finally stop at the P-gear
6. Make sure that the ATF overflow in the 35-45 range, lubricate the new seals when it stops overflow, and tighten the overflow plug.

1.4.2 AQ200 road tests

Test conditions

- a. Check and adjust the engine first
- b. ATF oil temperature in the range of 50 – 80°C under normal driving conditions
- c. turn off A/C and car light

Test items	Procedures
Gearshift function (D gear)	During normal driving condition, check the shift from first gear to second gear, third gear, fourth gear, fifth gear and sixth gear. (According to the speed range, the vehicle may not be able to switch to fifth gear or sixth gear)
Gearshift impact strength during driving	During normal driving condition, check for smooth upshifts
Forced kick down function	Kickdown through various gears to check the performance of the downshift . Check impact strength of forced downshift.
Engine brake condition	Check engine brake work condition of TIP gear.
Gear shift point at fully depress the accelerator pedal	Fully depresses the accelerator pedal in the D gear to check and confirm upshift speed from first gear to second gear upshift and to match with specified shift points.
TIP gear shift control function	Check to make sure the shift lever can be switched to any gear in the TIP mode.
Lock control function	Slightly depresses the accelerator pedal on level road during lock speed range to check and confirm if the engine revolutions has significant changes.
P gear work condition	Parked in the slopes (greater than about 5% or 3 degree) firstly, the shift lever in the P gear and release the parking brake , check to make sure the vehicle is not moving

1.4.3 Stall test

- Apply the parking brake and wedged the wheel.
- Apply chain fixed vehicle.
- Install the engine tachometer and start the engine.
- Fully depresses the brake pedal with left foot and switch to the D gear, fully depresses the accelerator pedal with right foot and quickly check the maximum revolution .

Test results	Possible cause
D and R gear value are less than the standard	Lack of engine power , T/C one-way clutch slippage
Only D gear value higher than the standard	Low line pressure (line pressure control solenoid valve [SLT] failure, main regulator valve failure), valve body failure (SLC1, hydraulic system), C1 clutch slipping one-way clutch F1 fault
Only R gear value higher than the standard	Low line pressure (line pressure control solenoid valve [SLT] failure, main regulator valve failure), valve body failure (SLC3, hydraulic system), C1 clutch failure (slipping), B2 brake failure (slipping)
Both D and R gear value higher than the standard	Low line pressure (line pressure control solenoid valve [SLT] failure, main regulator valve failure) oil pump failure, oil filtering network congestion

In order to avoid high ATF oil temperature, the test will not take more than five seconds

1.4.4 Pressure test

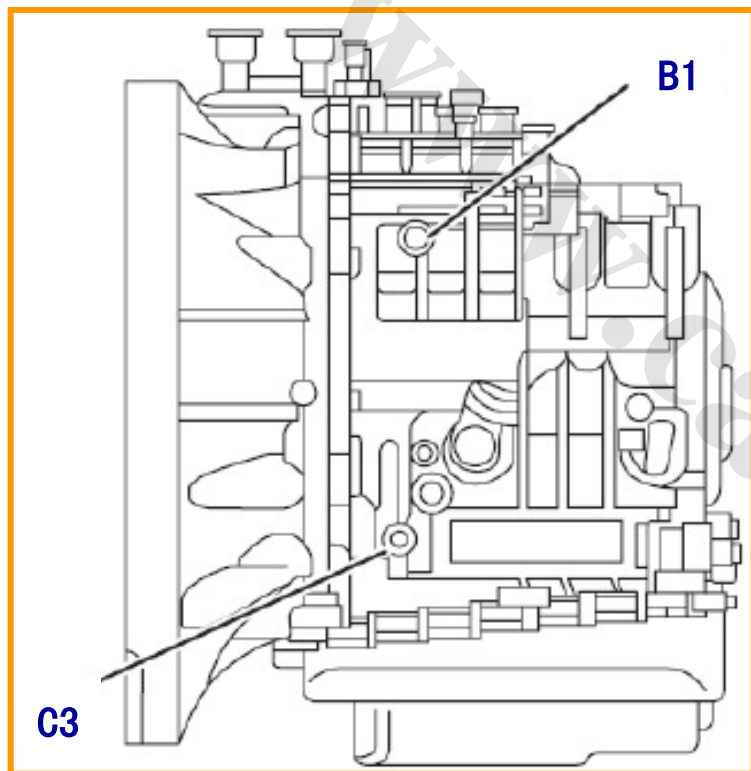

Idling	D gear	B1	337-437kpa
	R gear	C3	508-643kpa
Stalling	D gear	B1	1295-1500lpa
	R gear	C3	1875-2106kpa

Generally only use B1 and C3 inspection hole

Test results	Possible cause
D and R gear value are less than the standard	Line pressure control solenoid valve [SLT] failure Pressure regulator valve failure D or gear hydraulic circuit leakage
Both D and R gear value higher than the standard	Line pressure control solenoid valve [SLT] failure Pressure regulator valve failure
Only D gear value lower than the standard	D gear hydraulic circuit fault C1 clutch fault
Only R gear value lower than the standard	R gear hydraulic circuit fault C3 clutch fault B2 brake fault

In order to avoid high ATF oil temperature, the test will not take more than five seconds

1.4.5 Transmission time delay experiment:

Preparation before the test:

Check the oil level, engine temperature and transmission oil temperature reaches normal operating temperature.

→ During the gear selector shift from N gear to D gear range, using a stopwatch to measure the time from conversion to feel shock. Each test will be divided into three times measurement, using the following formula to calculate the average. Formula: the average time delay = $(\text{time } 1 + 2 + 3) / 3$

→ Perform the following shift test according to method described in second step.

- From the N position to R position

Time delay:

From the N position to D position: 0.4-0.7 s

From the N position to R position : 0.4-0.7 s

Transmission time delay experimental results analysis

Condition		Possible causes
N → D gearshift	Exceed of specifications	Low line pressure; forward gears clutch slipping; forward clutch fluid circuit leakage; shift solenoid valve A is not operating correctly.
	Lower than specifications	Front accumulator can not work properly; shift solenoid valve A is not operating correctly; excessive line pressure.
N → R gearshift	Exceed of specifications	Low line pressure; low speed and reverse gears brake slipping; reverse gear clutch slipping; shift solenoid valve B is not operating correctly.
	Lower than specifications	Improper operation of servo applications accumulator ; shift solenoid valve B is not operating correctly; excessive line pressure.

1.5.1 Hydraulic torque converter structure

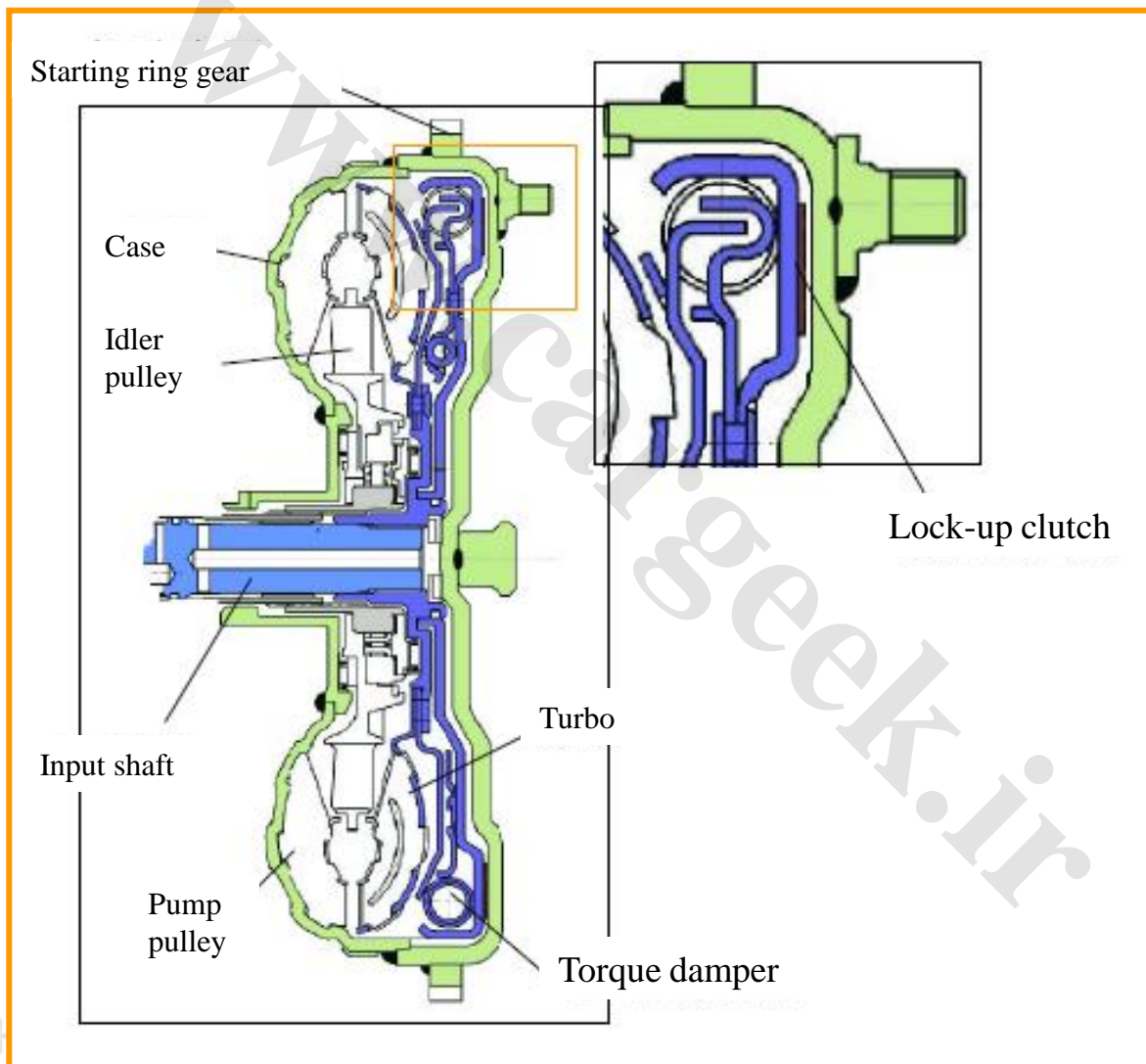

1.5.2 Hydraulic torque converter lock-up solenoid valve

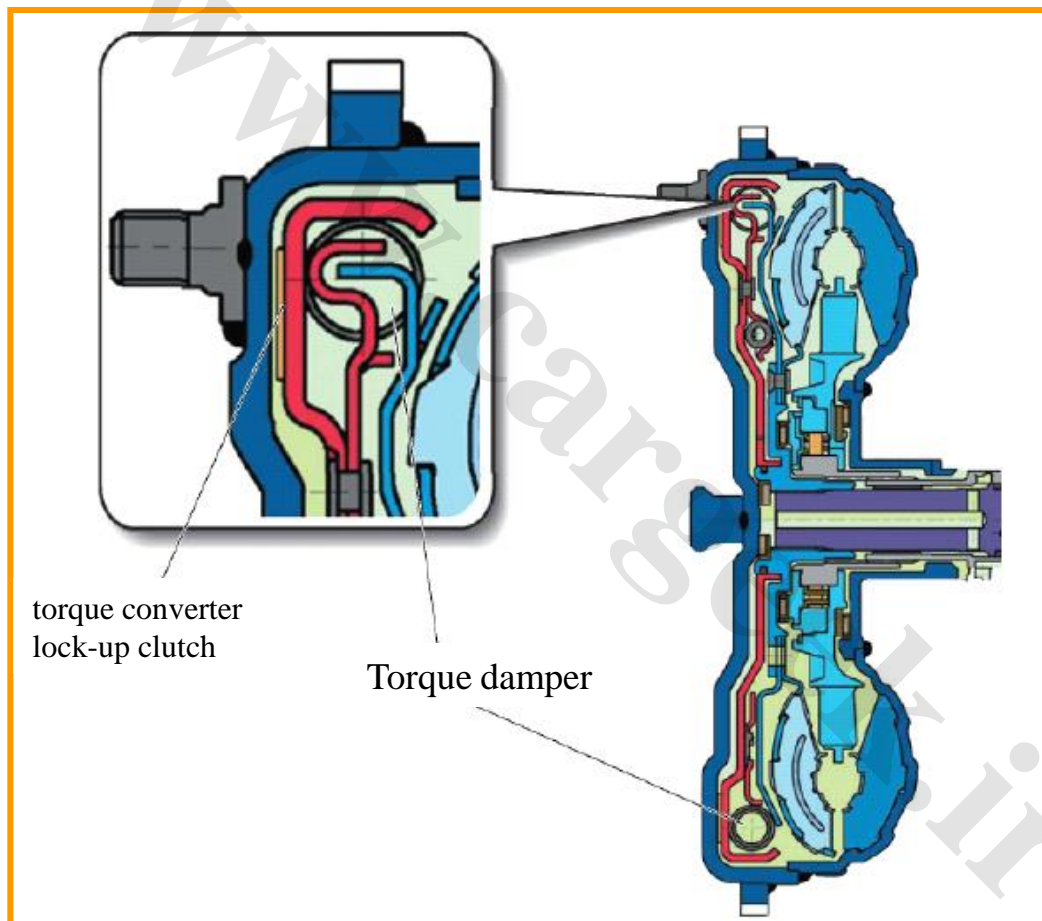

torque converter
lock-up clutch

Torque damper

1.5.3 Transmission profile chart

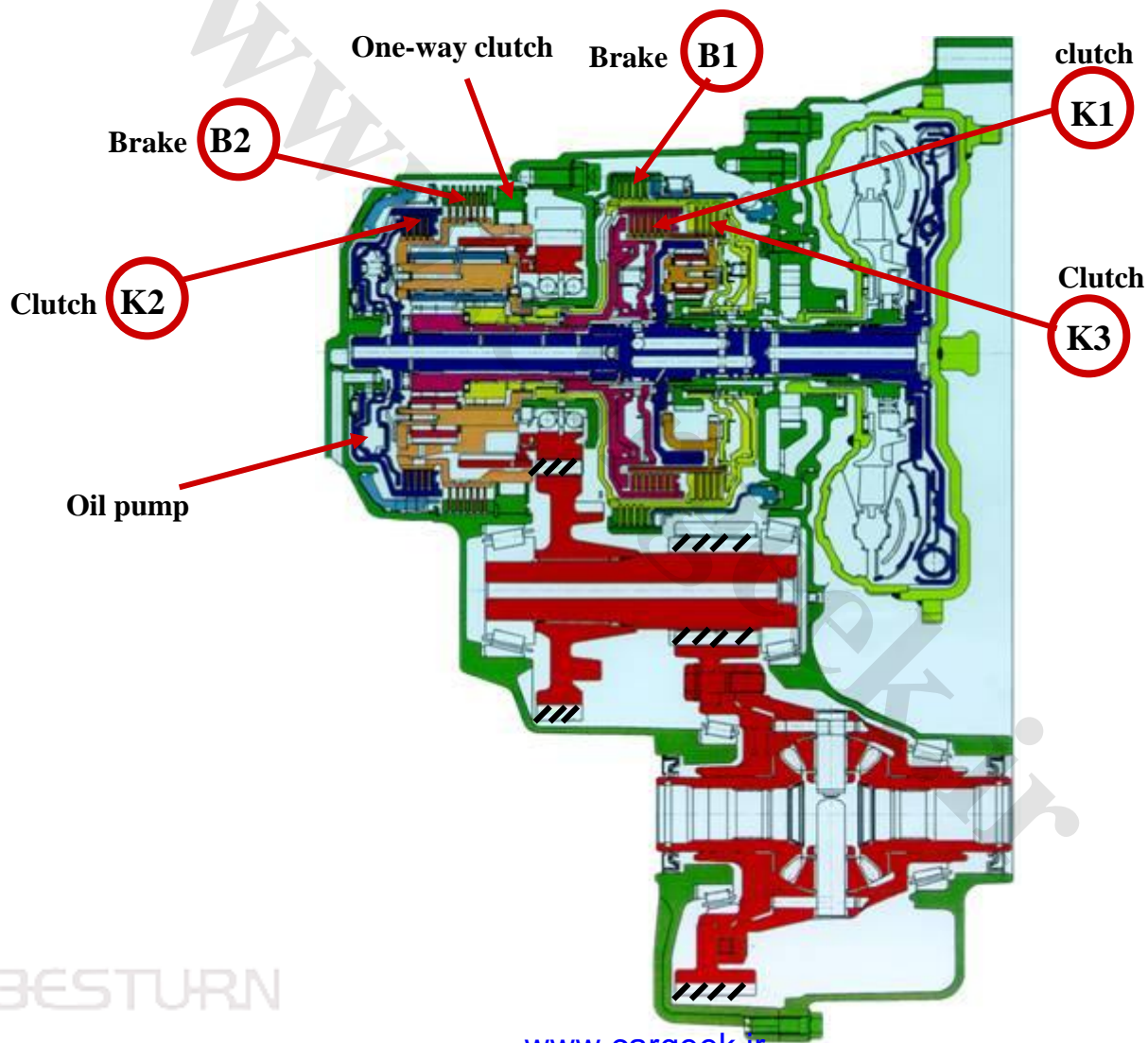

1.6 Working parts diagram

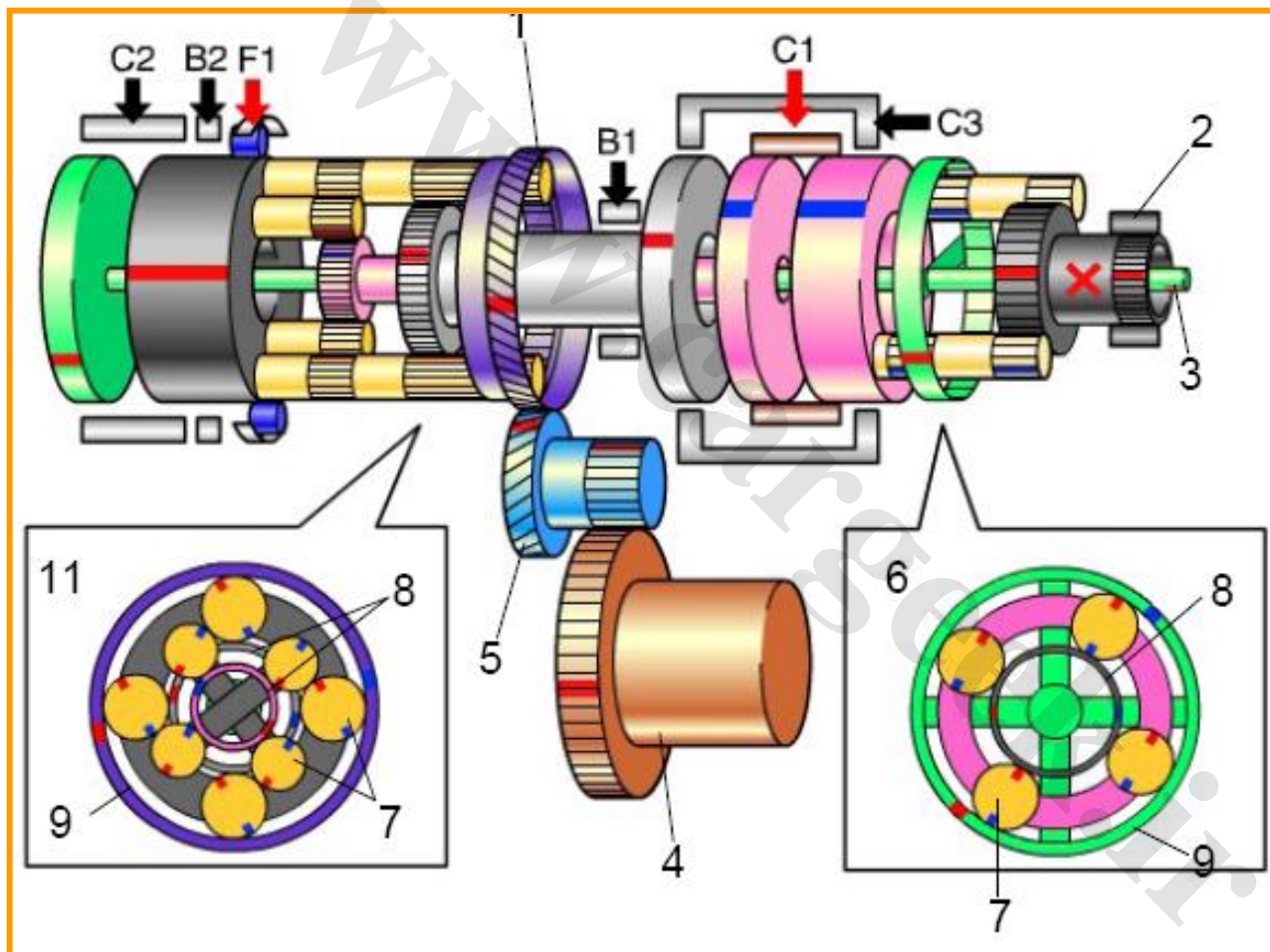

1. Intermediate shaft driving gear
2. Oil pump assembly
3. Input shaft
4. Differential gear assembly
5. Intermediate shaft gear assembly
6. First planetary gear
7. Pinion
8. Sun gear
9. Ring gear
10. Lock-UP
11. Rear planetary gear

1.7 AQ200 gear power transmission line



1st. swf



2nd. swf



3rd. swf



4th. swf



5th. swf



6th. swf



Rev. swf

2.1 AQ200 hydraulic control

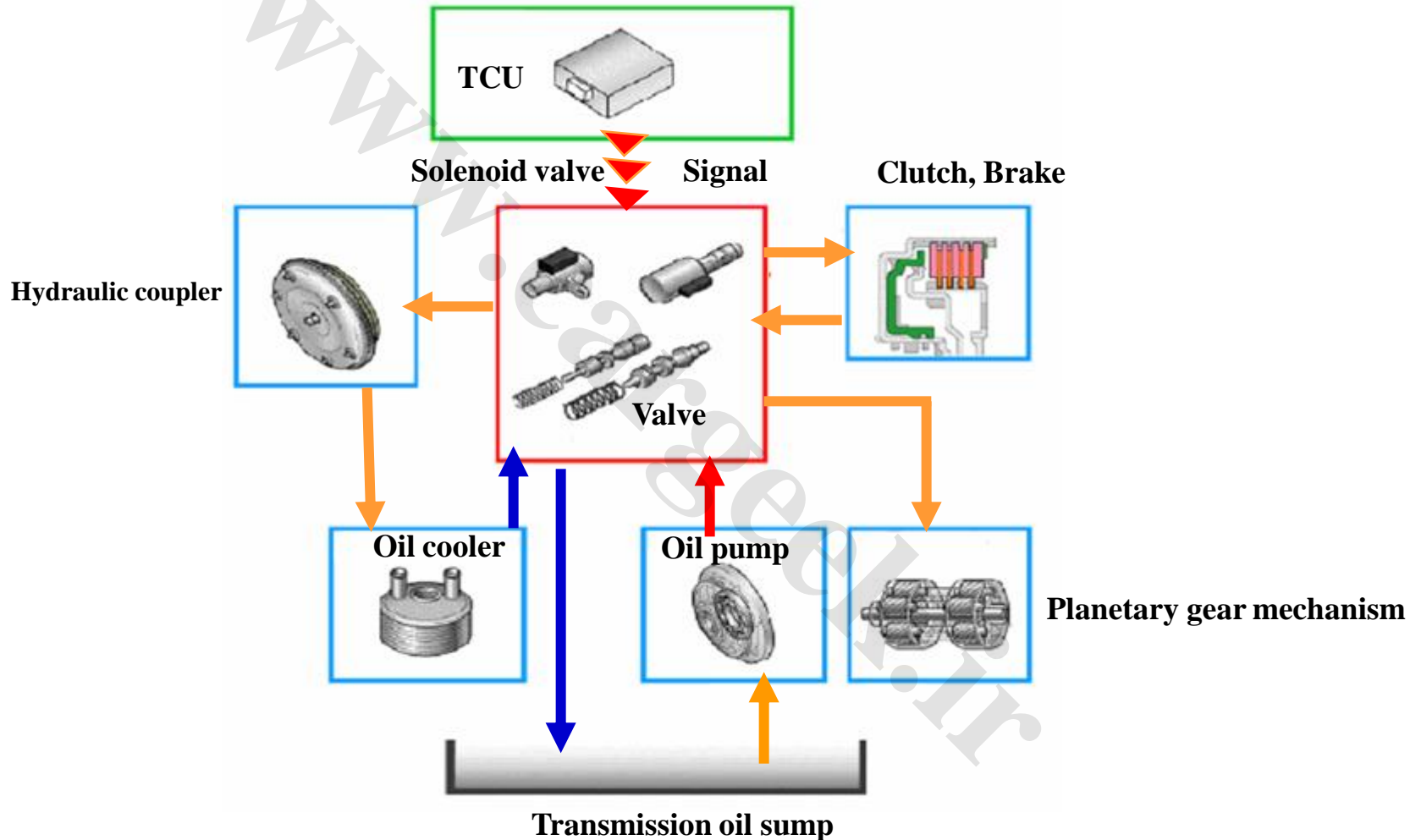

2.2 Automatic gear shift control

Shift lever position		Solenoid valve					Clutch			Brake		One-way clutch	
		SLC1	SLC2	SLC3	SLB1	S1	S2	C1	C2	C3	B1	B2	F1
P		○	○	○	○	—	—	—	—	—	—	—	—
R	Speed ≤ 9km/h	○	○	—	○	—	—	—	—	○	—	○	—
	Speed > 9km/h	○	○	○	○	○	○	—	—	—	—	—	—
N		○	○	○	○	—	—	—	—	—	—	—	—
D	First gear	—	○	○	○	—	—	○	—	—	—	—	○
	First gear engine brake	—	○	○	○	○	○	○	—	—	—	○	○
	Second gear	—	○	○	—	—	—	○	—	—	○	—	—
	Third gear	—	○	—	○	—	—	○	—	○	—	—	—
	Fourth gear	—	—	○	○	—	—	○	○	—	—	—	—
	Fifth gear	○	—	—	○	—	—	—	○	○	—	—	—
	Sixth gear	○	—	○	—	—	—	—	○	—	○	—	—

2.3 AQ200 Solenoid valve position

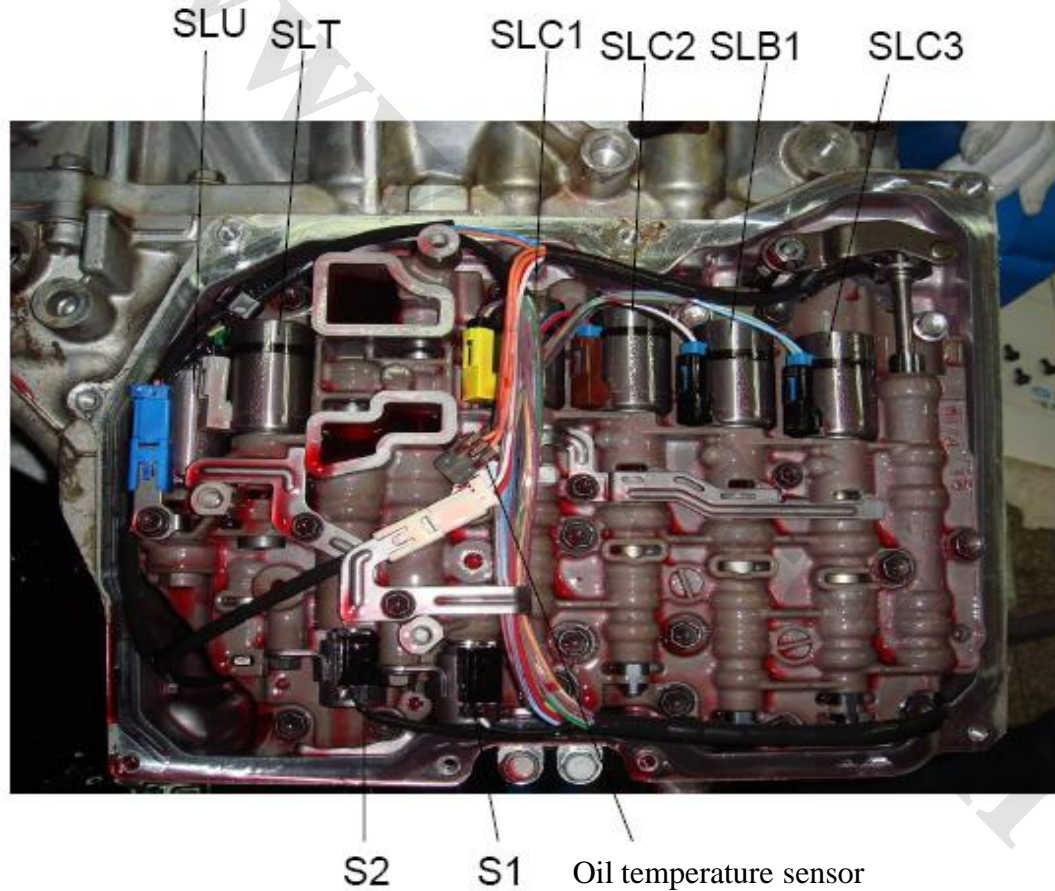

2.4 Speed sensor

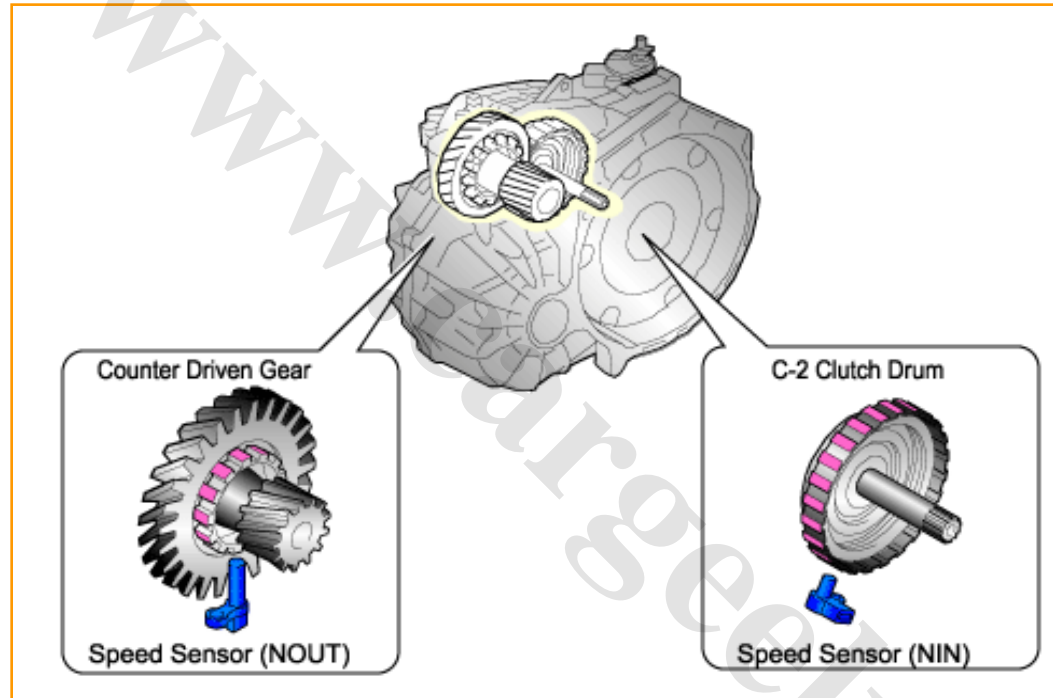

By these speed signals, ATCU decides gear-shift time and Lock-up

2.5 Automatic transmission control element relations

Shift lever position		Solenoid valve					Clutch			Brake		One-way clutch	
		SLC1	SLC2	SLC3	SLB1	S1	S2	C1	C2	C3	B1	B2	F1
P		○	○	○	○	—	—	—	—	—	—	—	—
R	Speed ≤ 9km/h Speed > 9km/h	○	○	—	○	—	—	—	—	○	—	○	—
	Speed ≤ 9km/h Speed > 9km/h	○	○	○	○	○	○	—	—	—	—	—	—
N		○	○	○	○	—	—	—	—	—	—	—	—
D	First gear	—	○	○	○	—	—	○	—	—	—	—	○
	First gear engine brake	—	○	○	○	○	○	○	—	—	—	○	○
	Second gear	—	○	○	—	—	—	○	—	—	○	—	—
	Third gear	—	○	—	○	—	—	○	—	○	—	—	—
	Fourth gear	—	—	○	○	—	—	○	○	—	—	—	—
	Fifth gear	○	—	—	○	—	—	—	○	○	—	—	—
	Sixth gear	○	—	○	—	—	—	—	○	—	○	—	—

2.6 TCU control function

Mode	Description
Economic gear	Use during normal driving conditions. Economic model is automatically selected depending on the circumstances
Sport gear	Move the shift lever from the D to the S gear, the shift points and lock-point set to be higher than normal driving conditions to make the engine produce high speed and high output.
TIP	Move the shift lever from the D to the M gear and change to M + (upshift) or M- (downshift), driver can select the desired gear , in order to achieve the driving dynamics sense of manual transmission , the TCU will upshift automatically to prevent over high speed, if the speed is reduced then it will downshift automatically and perform lock control.
High temperature	When ATF oil temperature is too high, this mode will activate lock-up function to stop the temperature rise and lower the temperature.
Warm-up shift mode	When the engine is cold, this mode will warm up the engine by maintaining first gear.
Uphill mode	TCU will check uphill condition according to the engine control module signals and ECU output speed during uphill drive condition, the TCU converted to uphill mode to prevent driving force decreased.
Downhill mode	TCU will check uphill condition according to the engine control module signals and ECU output speed during downhill drive condition, the TCU converted to downhill mode to decrease load applied on the brake.

1. Automatic shift control

2. Driver adaptive shift control

3 Lock-up control

- Lock-up control is realized by SLU according to the input and output speed signal, engine speed signal, throttle opening signal and speed signal.
- Fill the failed ATF oil may not be able to complete the locking control

4. Still shifting control

- Start the engine, N→D or N→R , line pressure control Solenoid valve (SLT) is used to supply hydraulic pressure required by C1 or C3 clutch, and suitably adjust the hydraulic supply to clutch to achieve vibration - free smooth engagement.

5 Reverse gear control

- $V > 9\text{km / h}$ can not enter the R gear.

6 Self-diagnostic function

- Online diagnostics: AT warning light flashes
- Offline diagnostics: TCU will record the DTC and read data using the F -ADS diagnostic equipment.

7 Fail-safe functions

- R: Reverse gear
- D: third gear

8 Initialization learn function

- When TCU or automatic transmission is replaced, it need perform initialization learning through F-ADS diagnostic equipment .
- Path: module programming / automatic transmission initialization learning

1) Warm-up

It ensures that the ATF oil temperature is between 66 -110 ° C

- Do not attempt to raise the oil temperature by making the engine stall.
- If the oil temperature is not between 66-110 ° C, you can not perform the initialization learning.
- Check shifting shock or gear change shock before study.

2) shifting learning on site

Depresses the brake pedal and move shift lever to the N gear for file 3 seconds when the vehicle is stationary. Then switch to the D from the N gear and remain in this state for 3 seconds. Repeat this process 5 times. Then for the R gear repeat this process five times in the same way.

3) Shift control learn

- Maintain the D gear and 40% to 60% throttle open angle firstly, drive when it reaches sixth gear and the speed for driving is 80 km / h or higher. Then, release the accelerator pedal to make the vehicle sliding and parking within 60 seconds. Repeat this procedure 10 times.

4) Check the learning results

- Make sure shifting shock or gear change shock is decreased compared to before the study

2.B50 automatic transmission control

www.CarGeek.ir

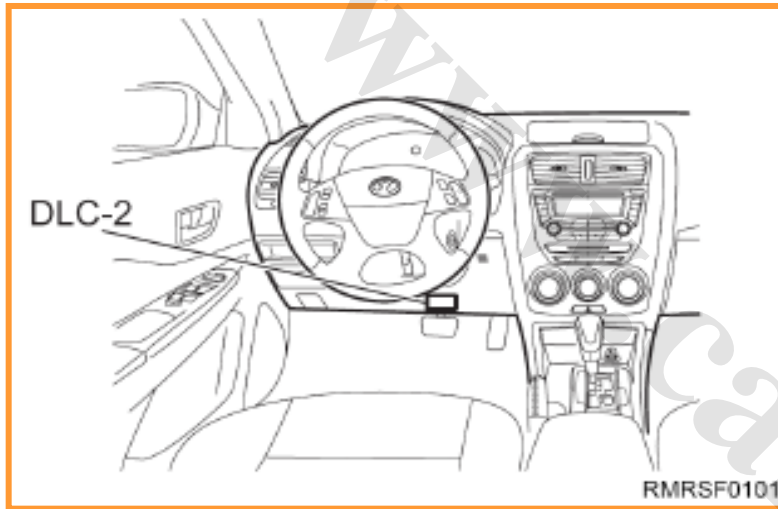

When TCU has replaced it should perform auto-configuration module first, then perform initialization learn.

< Prompt >

- When replaced the TCU must be configured first, otherwise the TCU may not work correctly.
1. Connect the F - the ADS diagnostic equipment to DLC -2.
 2. Select V11.02 edition diagnostics software, enter "system scan " mode.
 3. Select "Module Programming ".
 4. Select the "auto-configuration module ".
 5. Select the TCU and implement program in accordance with the prompts displayed on-screen.
 6. Retrieve the DTC through F -ADS diagnostic equipment, check to make sure no DTC exists.
 7. If DTC takes place, implement relevant DTC check.

www.cargeek.ir
Thank you!

奔腾 BESTURN

Technical Training of BESTURN B50

Vehicle suspension and drive axle

奔腾 BESTURN

Suitable post: Technical Director

Internal data, please do not disclose it externally

Curriculum Goals

- Familiar with basic structure of the suspension
- Familiar with basic structure of the manual transmission
- Basic adjustment of the suspension and drive axle

Contents



1. Suspension system parameters

2. Suspension system

3. Drive axle

1. Suspension system parameters

1.1 Front suspension system technical parameters

Items			Technical Specifications	
Front suspension	Type	It adopts high support double wishbone front suspension (double ball-hinged lower control arm)		
	Spring type	Coil spring		
	Shock damper type	Two-way effect drum (low pressure gas compression with the return buffer spring)		
	Stabilizer bar	Type	Twisted bar	
Diameter (mm)		23		
Front suspension	Wheel alignment (no load) * 1	Total toe-in	(mm)	Tires : 2 ± 2 , inside rim: 1 ± 3
			(Degree)	$5'24'' \pm 5'24''$
		Maximum steering angle	Internal	$39^\circ \pm 3^\circ$
			External	$31^\circ \pm 3^\circ$
		Kingpin back rake (Reference value)	*3	$3^\circ 24' \pm 1^\circ$
		Camber angle*2 (Reference value) Difference of left and right wheel should no more than 60'	*3	$-0^\circ 06' \pm 45'$
Kingpin leaning angle (Reference value)	*3	$5^\circ 14'$		

1.2 Rear suspension system technical parameters

Item			Technical Specifications	
Rear suspension	Type		E-type multi-link	
	Spring type		Coiled spring	
	Stabilizer bar	Type	Twisted bar	
		Diameter (mm)	18	
	Shock damper type		Two-way effect drum (charged with low pressure gas)	
	Wheel alignment (no load) * 1	Total toe-in	(mm)	Tire : 2 ± 2 , inside rim: 1 ± 3
			(Degree)	$8'36'' \pm 10'48''$
		Camber angle* ² (Reference value) Difference of left and right wheel should no more than 45'	*3	$-0^{\circ} 58' \pm 45'$
Thrust angle		(Degree)	$0^{\circ} \pm 6'$	

* 1: Level of engine coolant and lubricant in specified height; filled with fuel; spare tire, jack and tools should be placed in the specified location.

* 2: Angle deviation between the left and right must not exceed: front wheel 60 ‘rear wheel 45 ‘.

* 3: Distance between wheel center and the fender edge: front wheel 400 ± 20 mm, rear wheel 401 ± 20 mm.

1. Suspension system parameters www.CarGeek.ir



1.3 Standard parameters of tires and rims

Item		Technical Specifications	
wheel	Specification	15×6.0J	
	Offset	50mm	
	Distribution circle diameter	114.3mm	
	Material	Steel / aluminum alloy (spare tire /all steel wheel rim)	
Tire	Specification	195/65R15 91V	
	Tire pressure	Front	220kPa(less than four passengers)
		Rear	
Tread wear margin	1.6mm		
Wheels and tires	Wheel and tire runout	Radial	Maximum 1.5mm
		Lateral	Maximum 2.0mm
	Wheel unbalance	Clip-on balance weight * 1 : maximum 8g	

* 1 : Single balance weight : maximum 60g

If total clip-on balance weight exceed 70g , then turn the tire on the rim , and then re-balanced . Balance can only use up to 2.

2.1 Suspension system structure and location

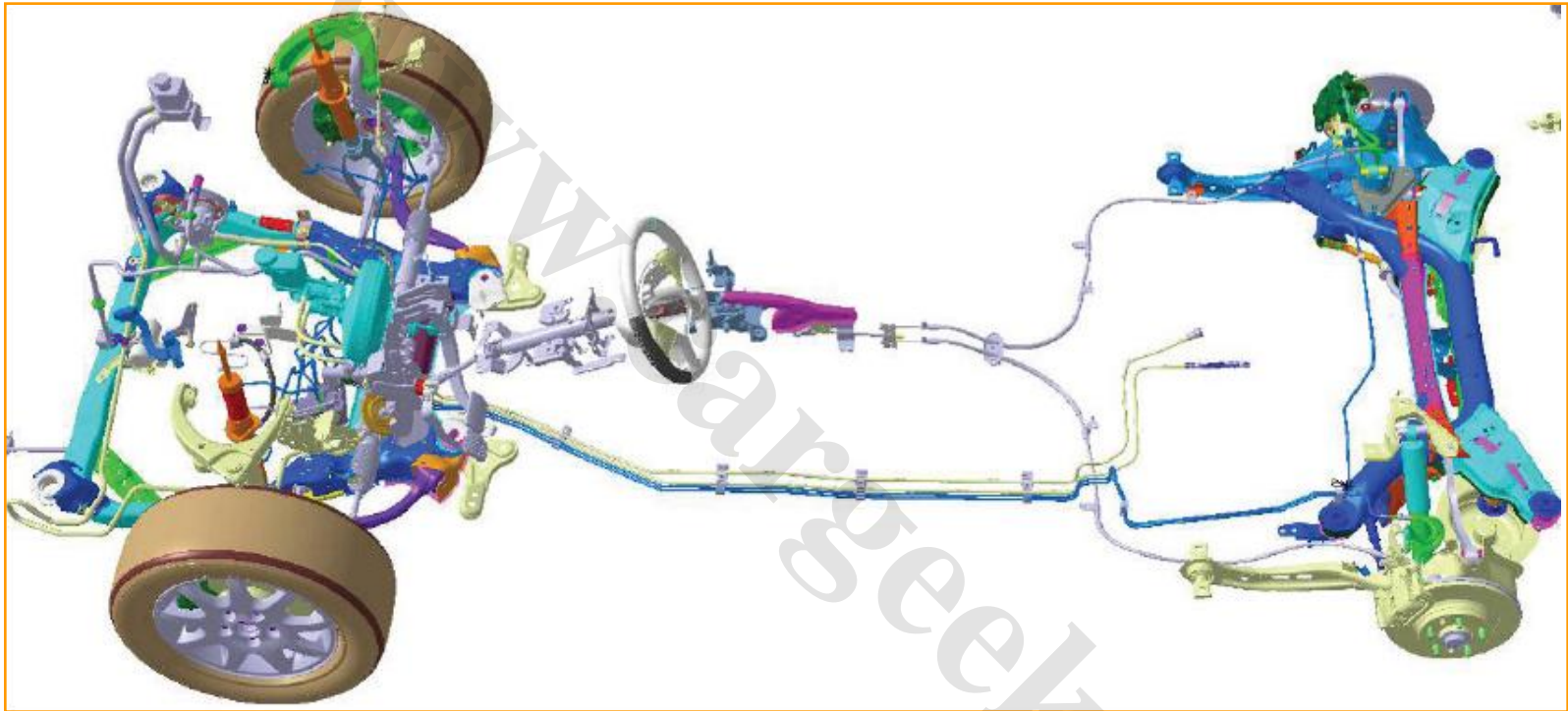

2.2 Front Suspension Parts Location Map

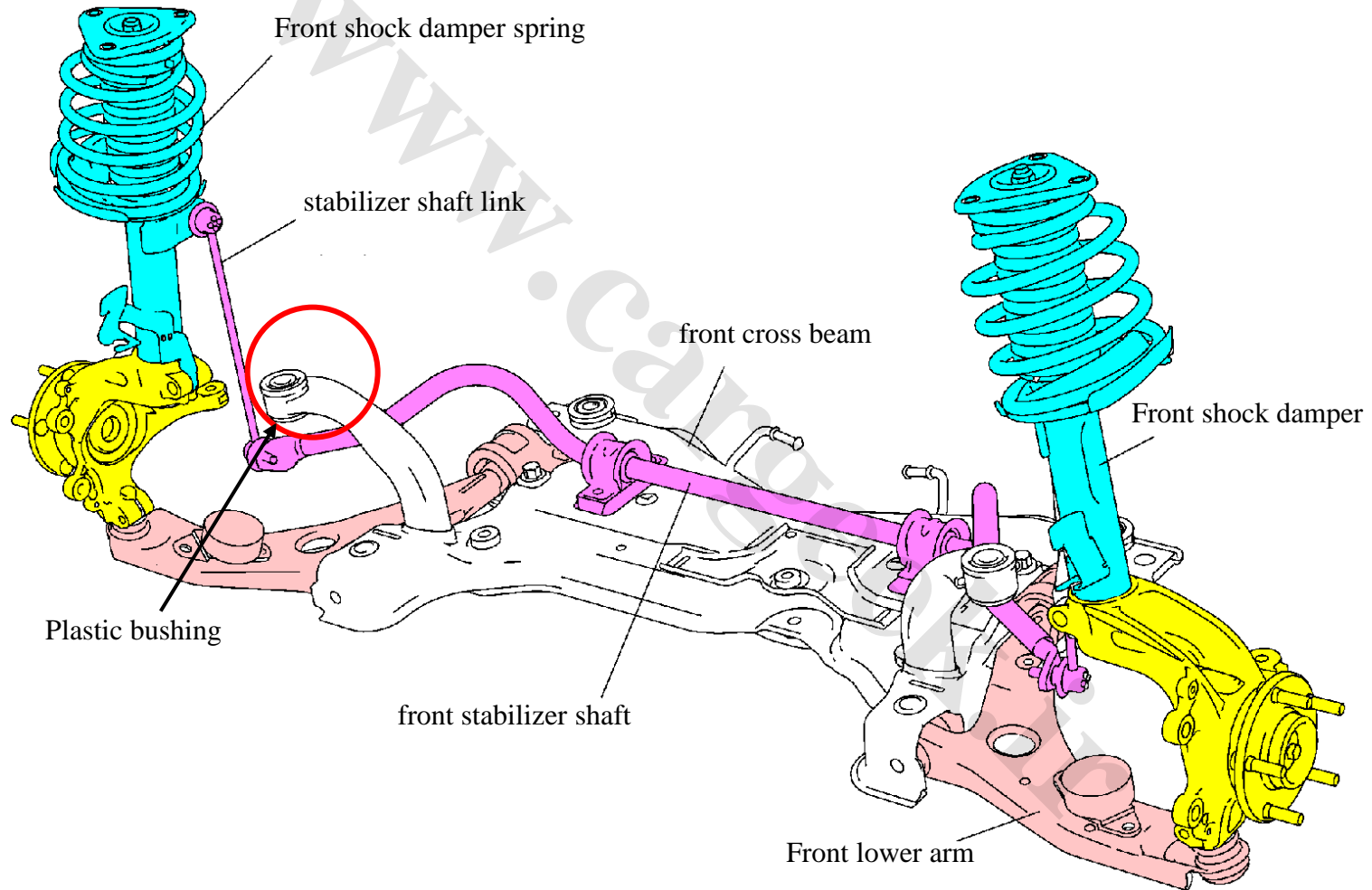

2.3 New features of the front suspension (beam)

Front cross beam adopts a four-point rubber bearing system

- High control stability and low NVH, and with no loss of base rigidity.
- It can absorb the impact force, and make the bearing deformation to reduce the impact force when during lower part impact occurs. And the bush will drop off in the 3-5 tons of impact force, so can reduce the impact force.
- Suspension adopts high bearing wishbone structure (double-ball hinge lower control arm is characterized by the small kingpin offset distance, thereby reduce inertia moment of the wheel around kingpin) , the upper and lower control arm lever design is a traditional wishbone suspension structure.
- Front suspension and connecting rod design can meet common needs of handling stability and driving comfort, make the vehicle have right control features of the right front wheel extraversion.
- Inertia moment of wheels around kingpin axis can be reduced as short kingpin offset distance.
- Low- friction spherical hinge, improves steering response and smooth performance.
- There is a recovery buffer spring and separate input type shock absorber seat in the front shock damper and coil spring, they can improve the damping force, and can improve cornering ability when changing lanes. It can reduce the piston rod speed range to improve the driving comfort.

2.4 New characteristics of the front suspension (springs and lower arm)

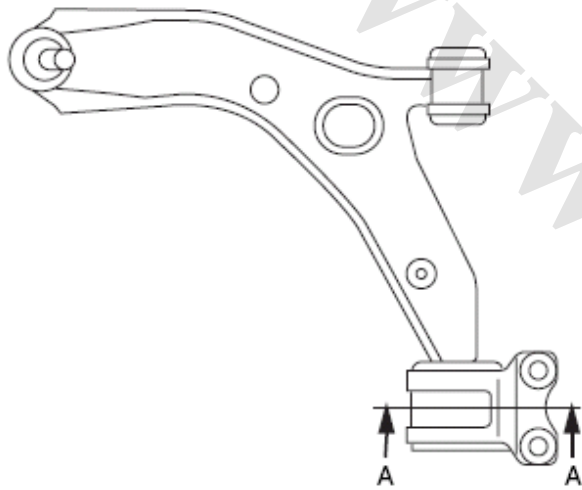

Front shock damper structure

- Using a high response shock absorbers with large piston diameter .

Front lower arm structure

- Rear side of front lower arm adopts oil charged bushing.

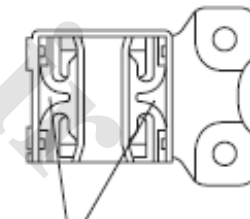
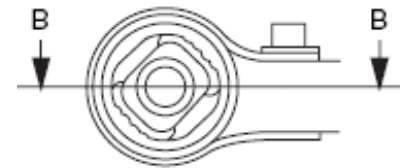

Damping silicone oil

2.5 Adjust of front wheel total toe-in angle

- The two steering knuckle tie rods both adopt right hand thread and therefore turn the right steering knuckle tie rods to the front of the car , turn the right to rear of the car to increase the toe-in .
- Turn the two tie rod one full turn can change toe-in about 6mm (0 ° 36 ') .
- Fastening tie rod end nut according to specified torque. Tightening torque :68.6 -98 .0 N ·m

2.6 Structure of the rear suspension system

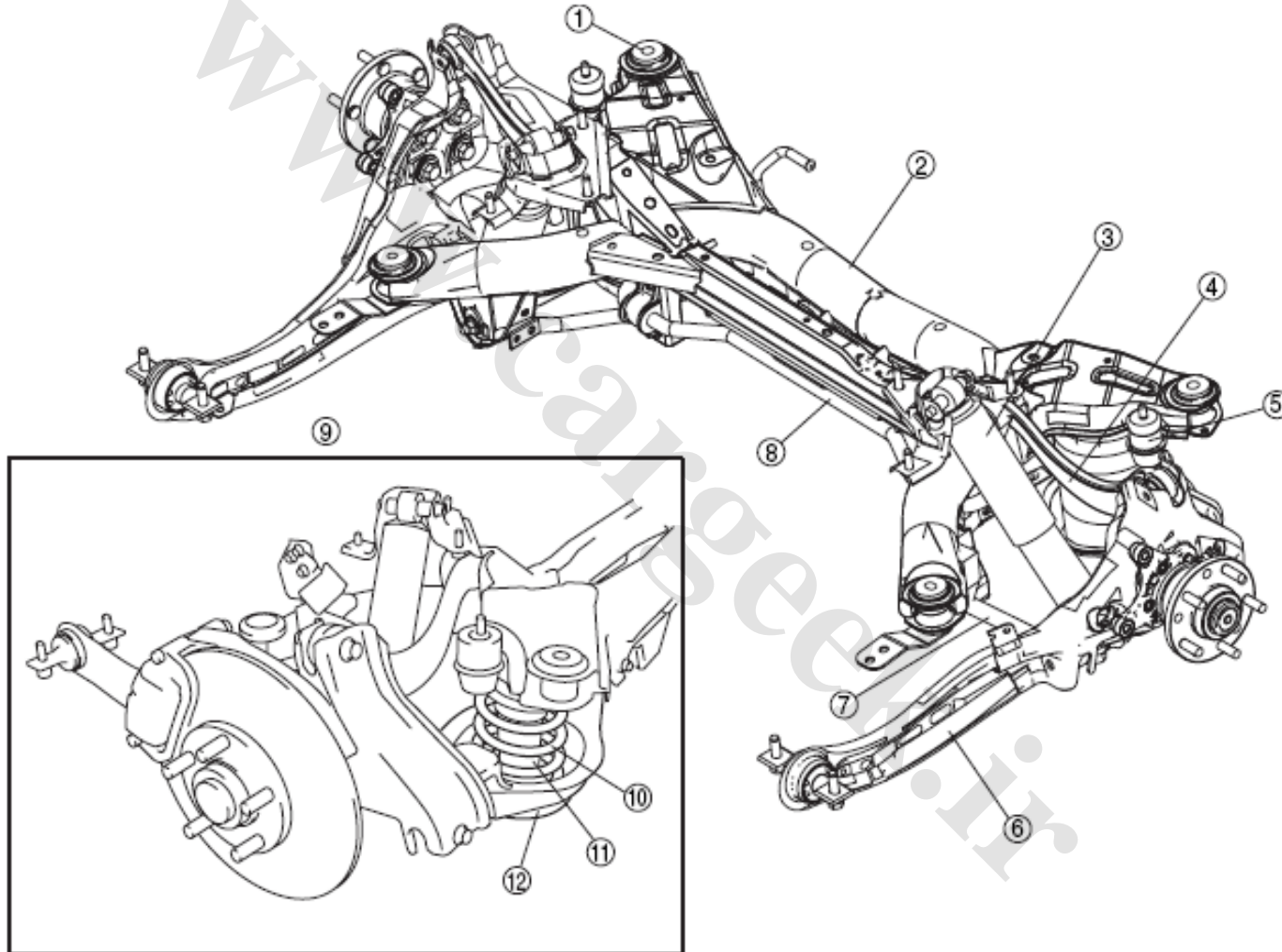

E-type multi-link rear suspension system

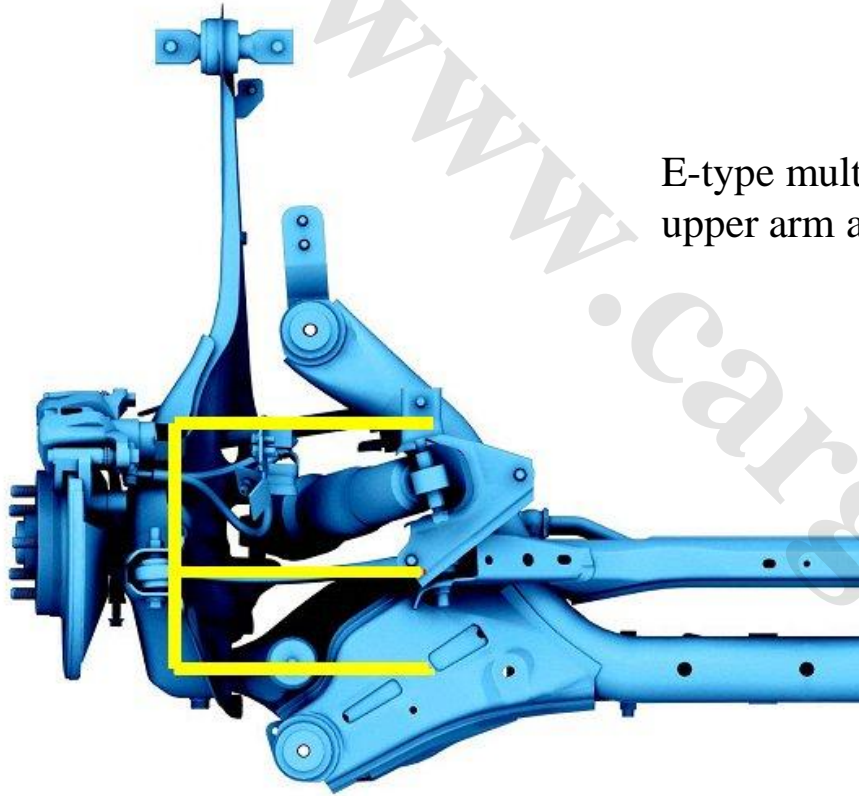

E-type multi-link is composed by a former drag arm, rear upper arm and lower arm, and they form the E-type.

2.7 Rear suspension system features

- It adopts E-type multi-link rear suspension system.
- Luggage space is more spacious as shock damper and coil spring are separated.
- Separated shock absorbers and coil spring can reduce lateral force of the shock damper; this can make the suspension system work smoothly and improve driving comfort performance.
- In addition to the separate configuration of the shock damper and coil spring, the E- type multi-link Rear suspension linkage layout similar to layout of the commonly used multi-link rear suspension linkage.
- Coil spring and shock damper installs separately, coil spring is installed between rear subframe and rear lower control arm. Short distance between shock damper and coil spring can make passenger compartment floor lower and smoother.

2.8 Adjust of rear wheel total toe-in

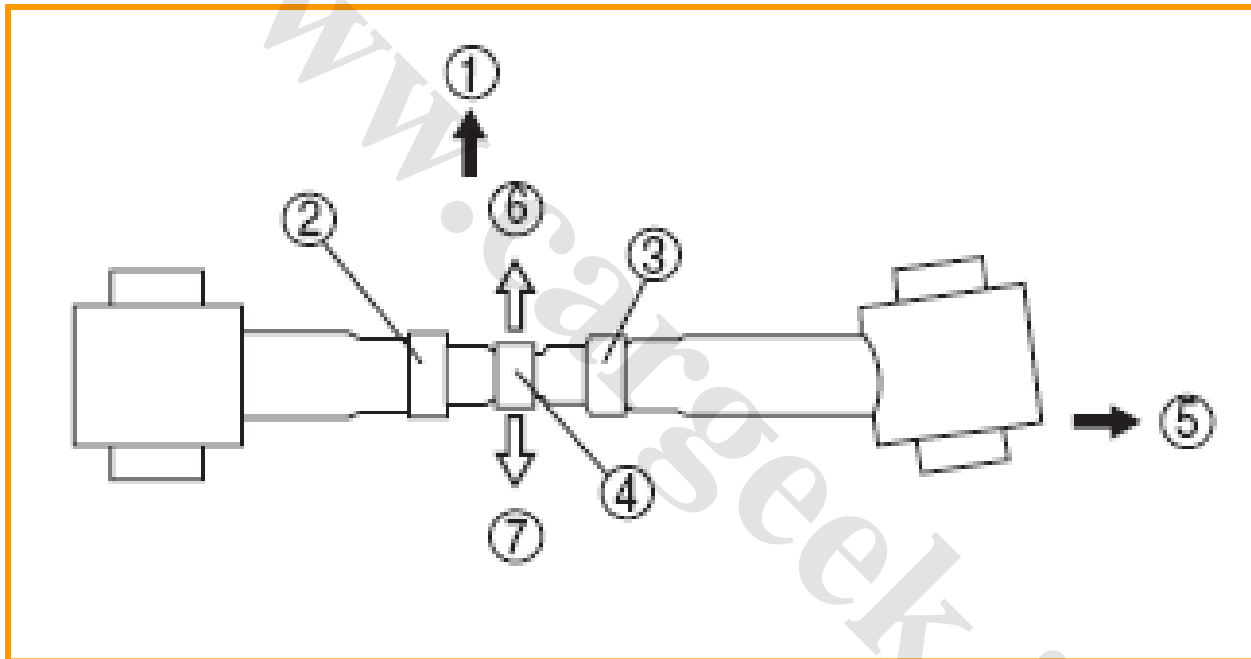

2.9 Rear wheel extraversion adjustment

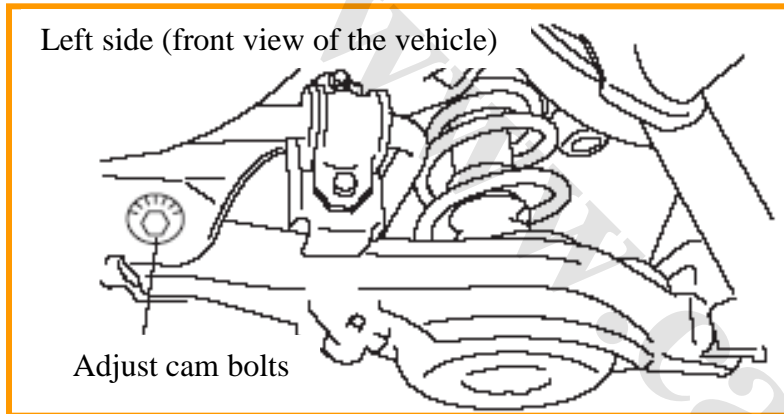

- Loosen cam nut of the lower control arm .
- Rotate the cam bolt to adjust the marked right camber angle .
- Tighten the lock nut with torque 68.6 - 98.1N.m

	Left wheel	Right wheel
Positive direction	Clockwise	Counterclockwise
Reverse direction	Counterclockwise	Clockwise

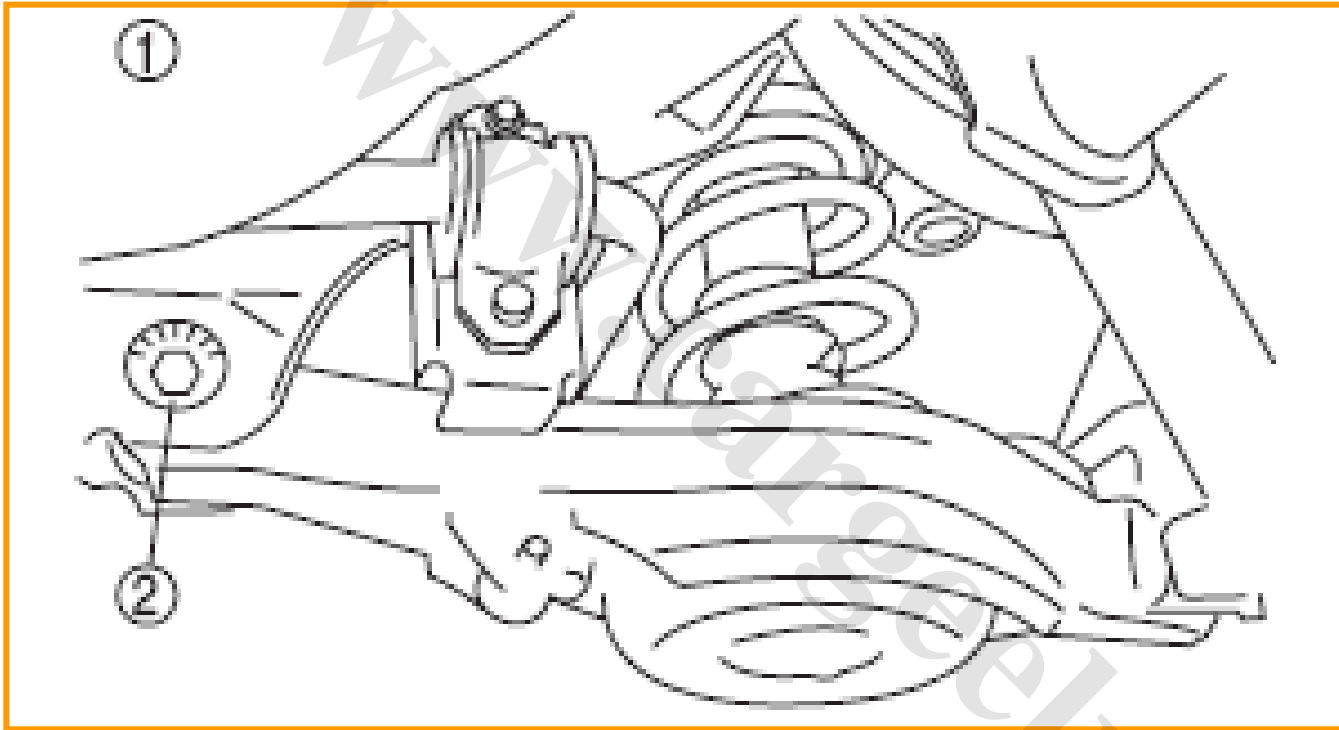

- Adjust rear wheel extraversion through rotate adjusting cam of rear lower control arm , each cam a scale will change the wheel camber about 20 minutes.

3. Drive axle

3.1 Drive axle structure

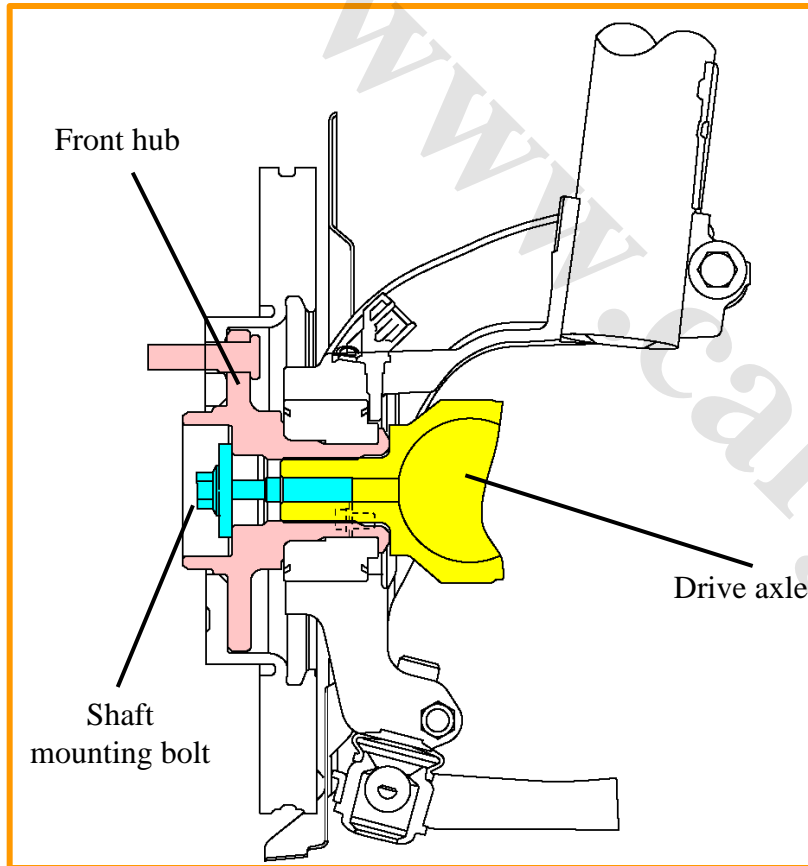

Front

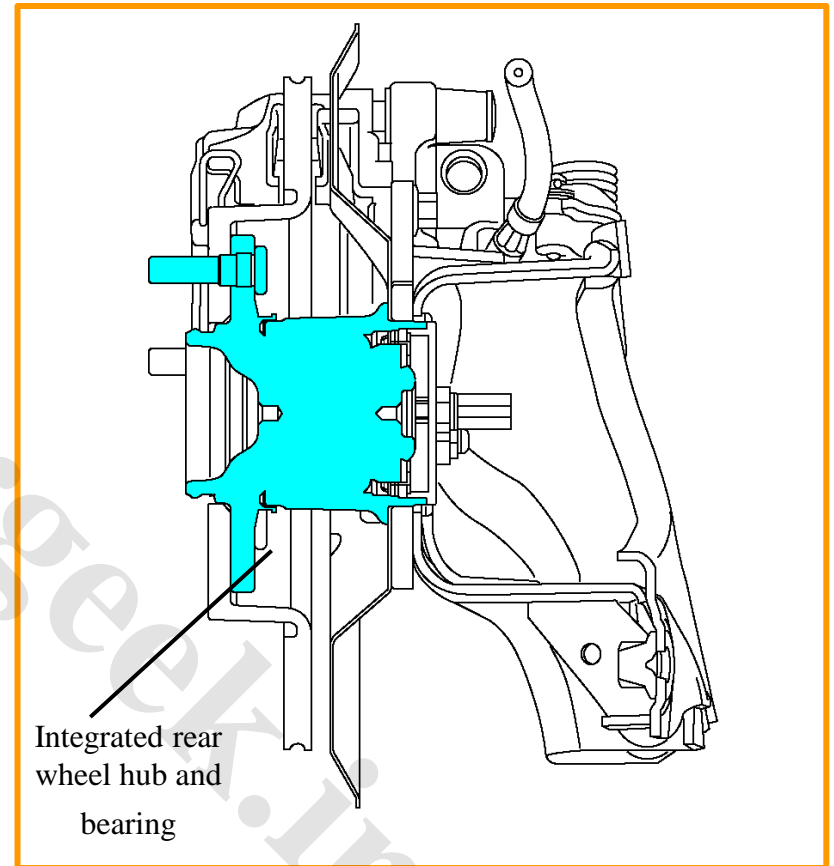

Rear

3.2 Front wheel hub maintenance points (overall replacement)

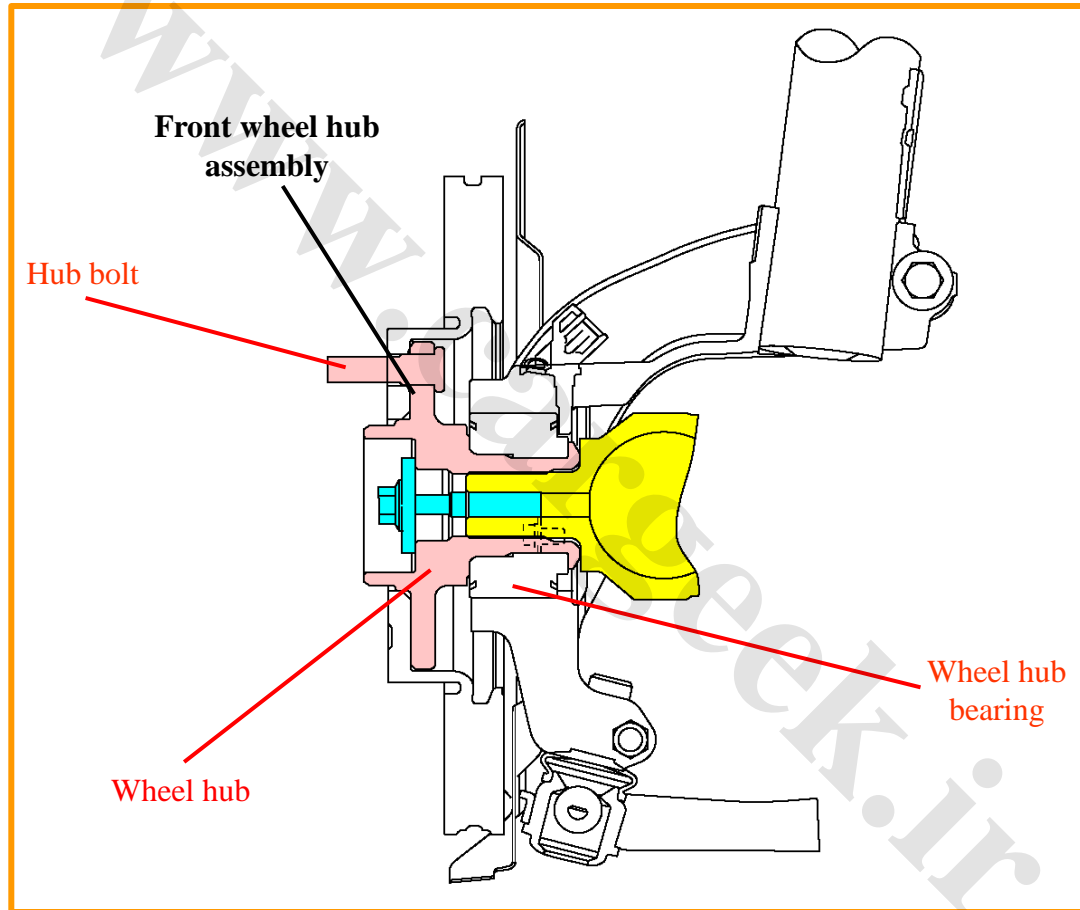

No separate supply wheels hub, wheel hub bearings and wheel hub bolt.

3.3 Front wheel hub maintenance points (plastic bolt one-time use)

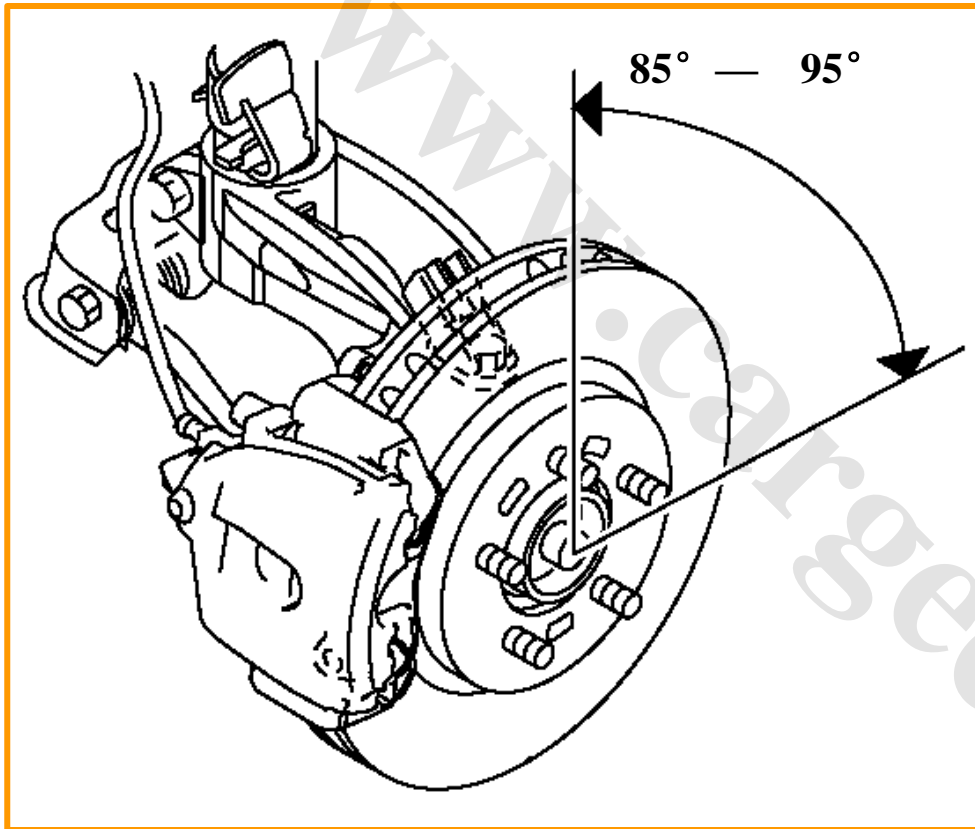

Put new fixed bolts

Step one: Tighten

31.5-38.5 N ·m

Step two: rotate 90 °

3.4 Rear wheel disassembly

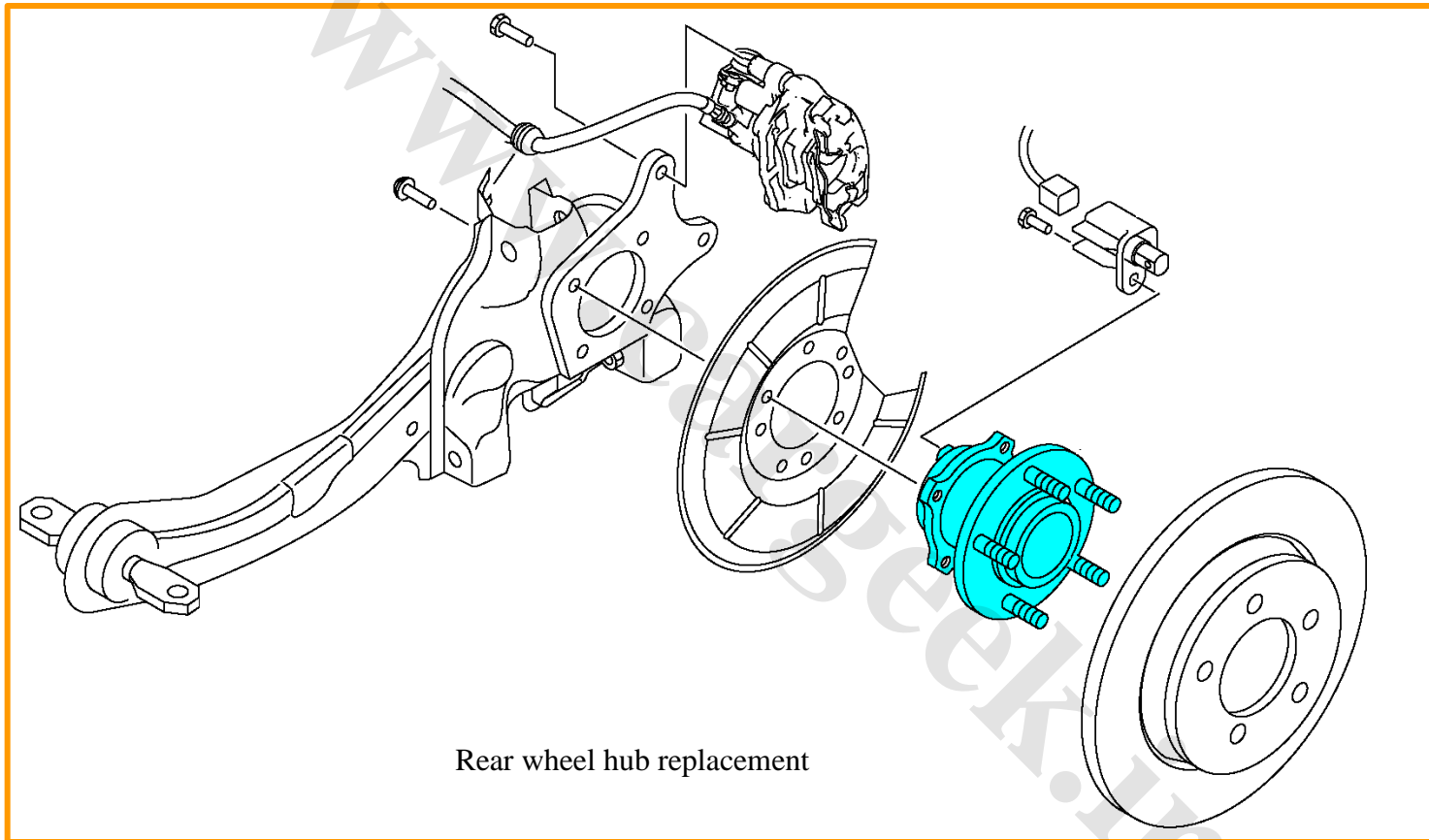

www.cargeek.ir
Thank you!

奔腾 BESTURN

Technical Training of BESTURN B50

Vehicle brake and brake electronic control

奔腾 BESTURN

Suitable post: Technical Director

Internal data, please do not disclose it externally

Curriculum Goals

- Understand structure of the traditional braking system
- Understand structure of the ABS / EBD control systems
- Familiar with diagnostic equipment to diagnose and repair electronically controlled brake

Contents

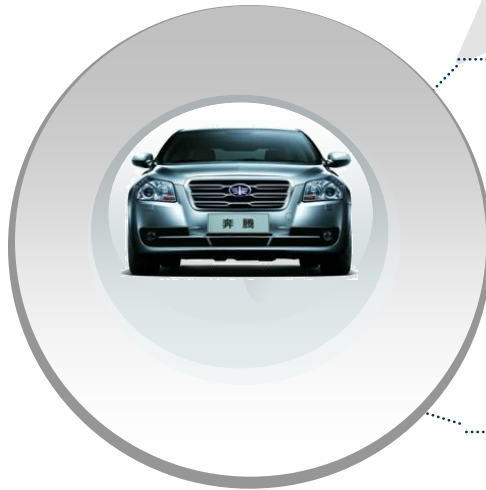

1. Conventional braking system

2. Role of ABS/EBD system

3. ABS/EBD structure and overhaul

1. Conventional braking system

1.1 Structure diagram of the conventional brake parts

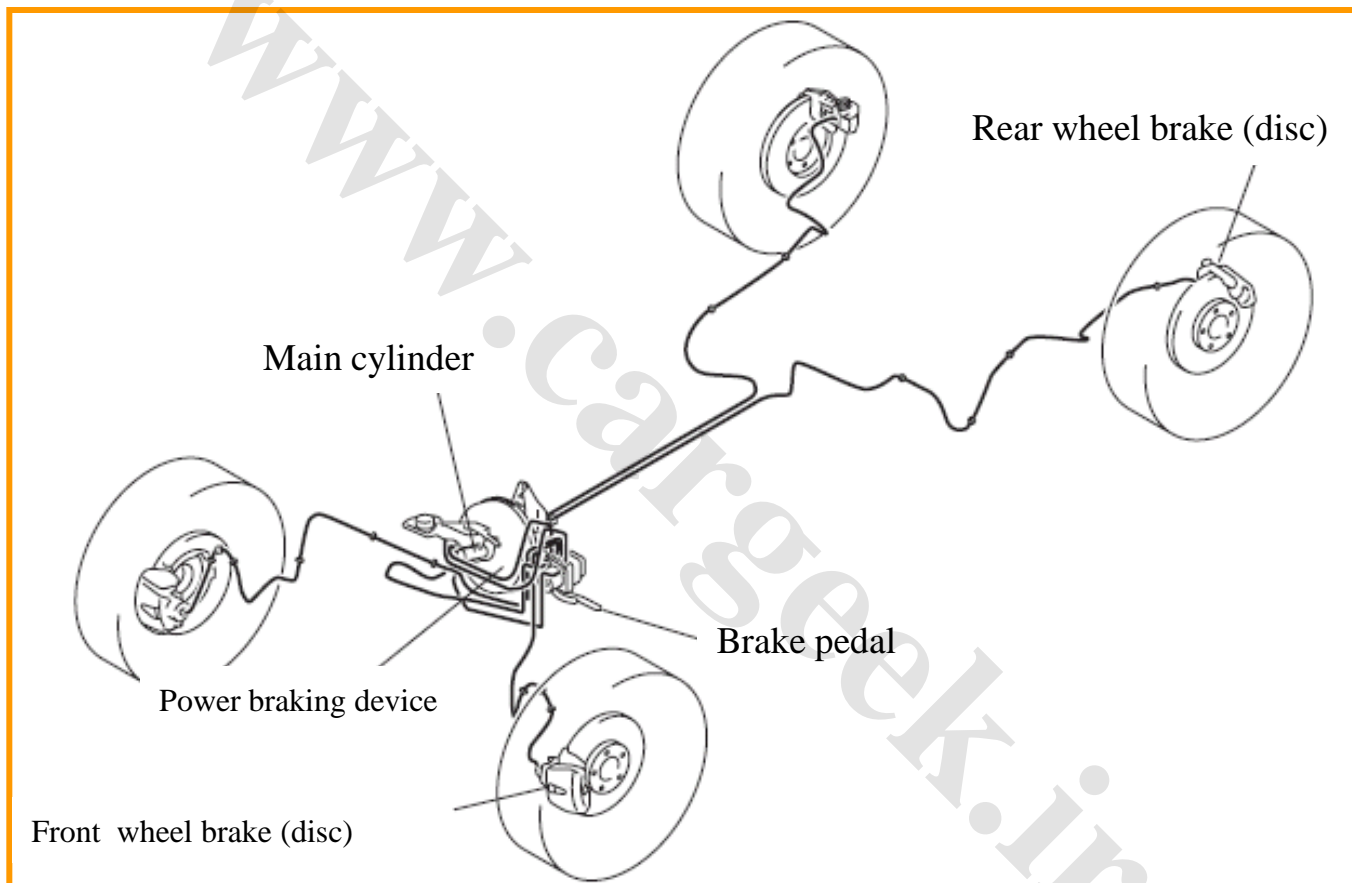

Anti- inward irruption brake pedal

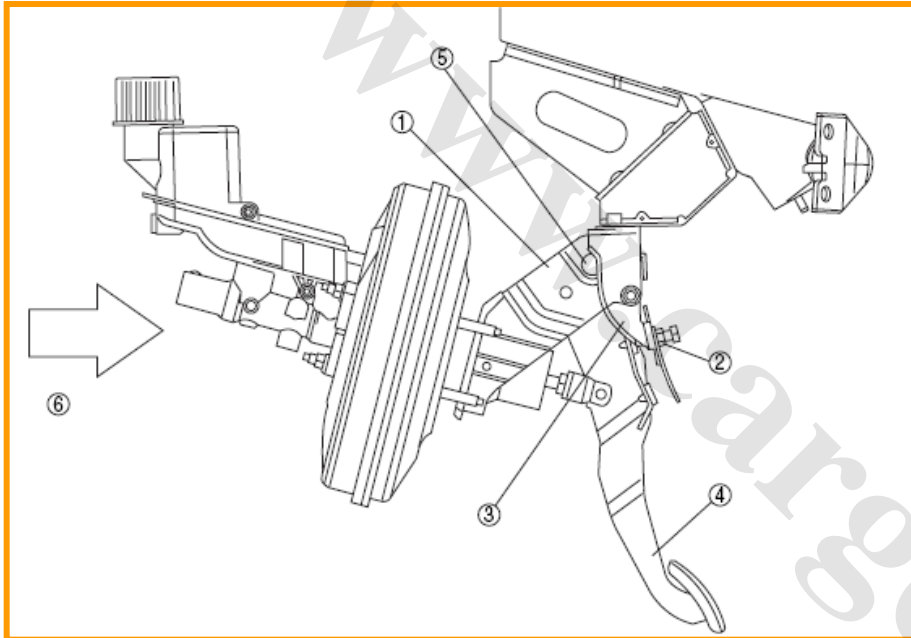

- **Anti- inward irruption the brake pedal**
 - In the process of a frontal collision, counter thrust of the engine and other parts can force the brake pedal bracket A move backward, it will separate with brake pedal bracket B.
 - Brake on the brake pedal bracket B can prevent brake pedal lever of the brake pedal bracket A move backward.
 - For this reason, displacement of the brake pedal bracket A can prevent brake pedal rod move backward.

1. Conventional braking system

Structure of power braking devices

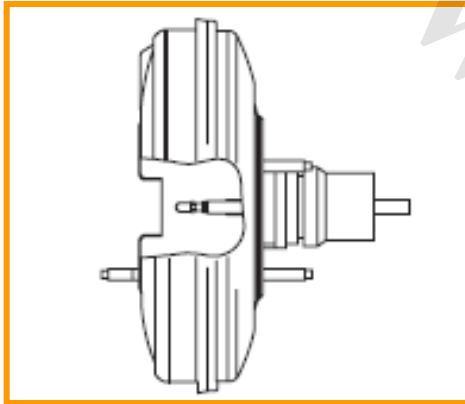

- It adopts 10-inch, single-diaphragm vacuum booster, and can combine the high braking performance with the best braking feel.

Structure of front brake (disc)

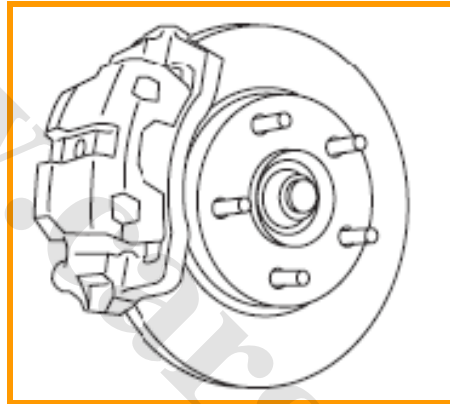

- It adopts a large-diameter ventilated disc front brake with diameter of 274mm and thickness of 24mm to improve the braking force and antidamping performance.

Structure of rear brake (disc)

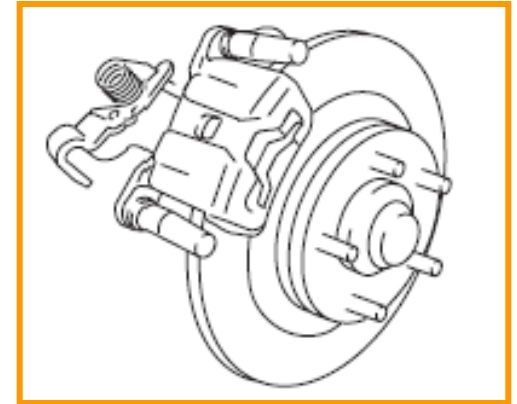

- It adopts a large-diameter solid disc front brake with diameter of 280mm and thickness of 10mm to improve the braking force and antidamping performance.

1. Conventional braking system

1.2 Component parameters of the traditional braking system

Items	Specifications
Brake fluid type	European (L.H.D.U.K) specification SAE J1703, FMVSS 116 DOT-3 or DOT-4
Brake pedal height (reference value)	187 mm
Brake pedal clearance	0-3 mm
Clearance between the brake pedal and the floor (@588 N- { 60 kgf , 132 lbf } of brake pedal pressure)	68 mm or more
Power braking device fluid pressure@200 N{20 kgf, 44 lbf} of brake pedal pressure, @0 kPa {0 mmHg, 0 inHg}	590 kPa{6.02 kgf/cm ² , 85.6 psi}
Power braking device fluid pressure@200 N{20 kgf, 44 lbf} of brake pedal pressure, @ 66.7 kPa {500 mmHg, 19.7 inHg}	8,780 kPa {89.53 kgf/cm ² , 1,273 psi}
Front brake disc runout limit	0.05 mm
Minimum thickness of front brake discs [Europe (L.H.D.U.K) specification]	23 mm
Minimum thickness of the current car front brake disc machined with lathe [Europe (L.H.D.U.K) specification]	23.8 mm
Rear brake disc runout limit	0.05 mm
Minimum thickness of rear brake discs	8 mm
Minimum thickness of the current car rear brake disc machined with lathe	8.8 mm
Minimum thickness of rear brake disc pad	2.0 mm
Brake lever stroke @98 N{10 kgf, 22 lbf} force	3—6 notch

1.3 Anti-inward broke into the brake pedal

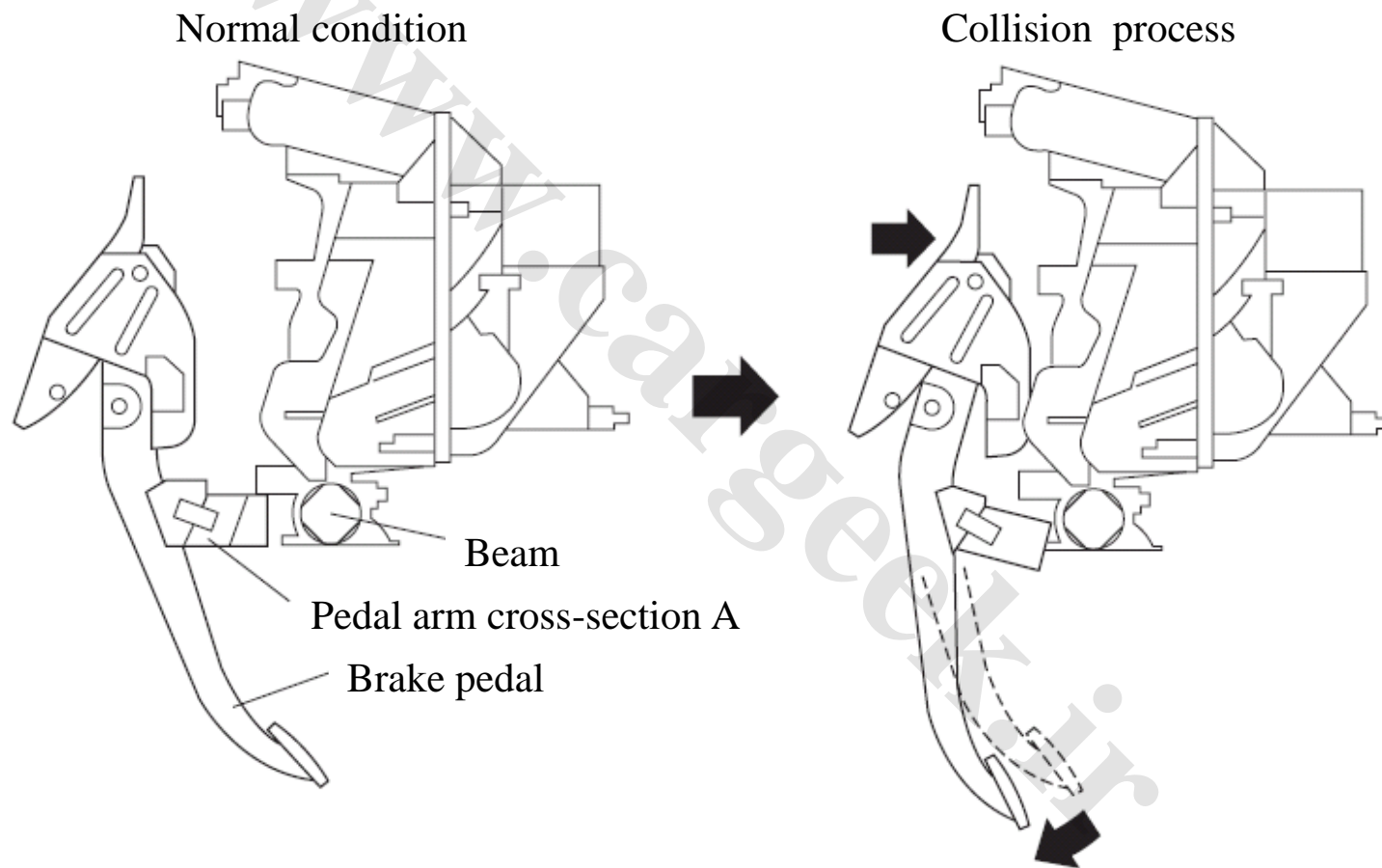

1.4. B50 electronic vacuum pump structure and function



Section plan



Sectional view

Connect condition: when compared with the ECU model curve, the intake manifold vacuum is too low, and the ECU will send a ground signal to the electronic vacuum pump, so that the circuit connected. under different altitude conditions, the connected pressure is various. . Every time you start the engine, the electric vacuum pump will operate for 1 to 2 seconds.

B50 electronic vacuum pump operation

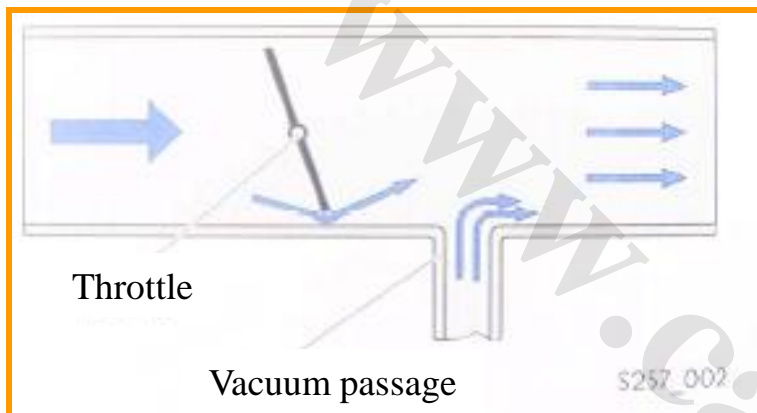

Small throttle opening angle

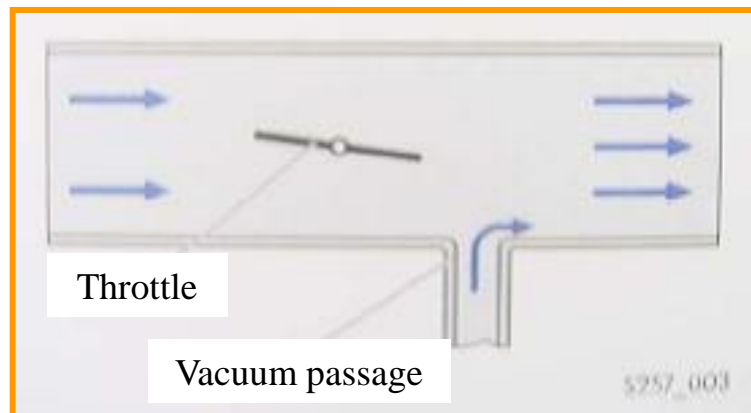

Large throttle opening angle

For automatic transmission models that meet the Euro III or Euro IV emission standards, when tread the brake pedal and run in idle speed, the throttle opening angle will particularly large in the cold start and gear engage condition.

1. Conventional braking system

B50 Electronic vacuum pump test

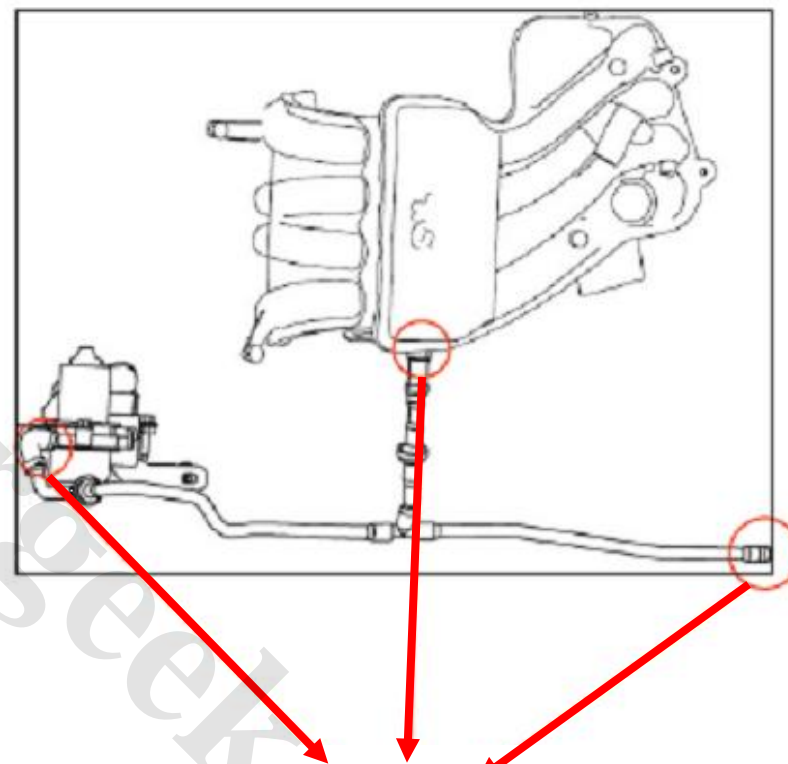
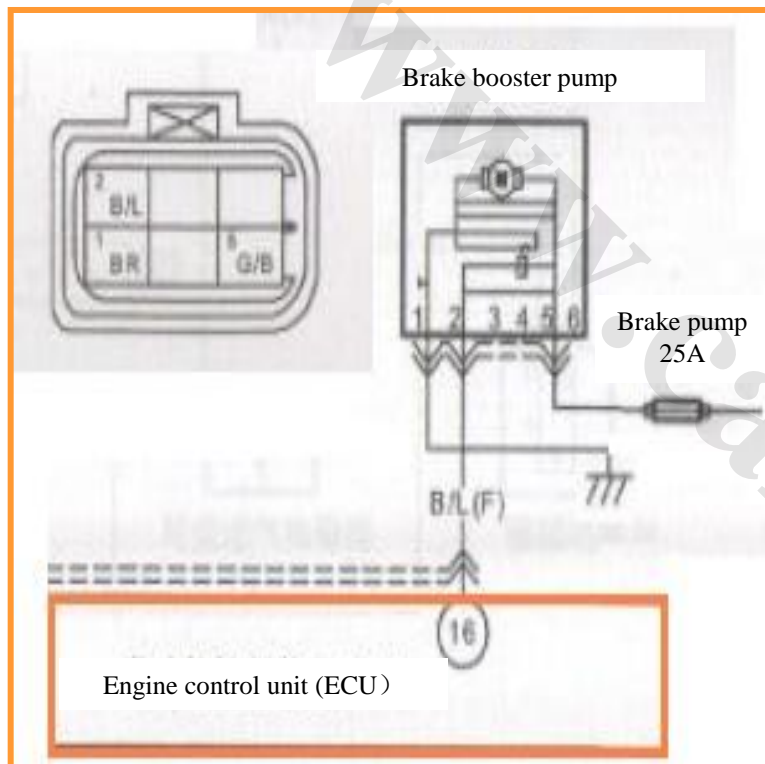

Any of this three point disconnects and then reconnects will need F-ADS diagnostic equipment to execute vacuum pump test.

Test path: Powertrain / OBD parts test / single test / vacuum pump test

2.1 Classification and Function of the electronic brake

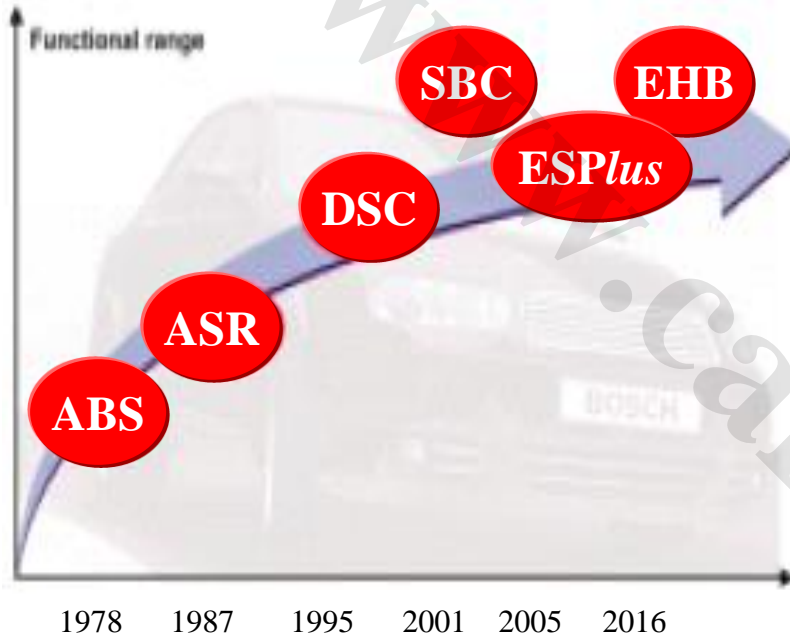

Description of the figure abbreviation:

ABS: Anti-lock Brake System

ASR: Acceleration Slip Regulation

TCS: Traction Control System

DSC: Dynamic Stability Control

SBC: Sensotronic Brake Control

EHB: Electrohydraulic Brake

2. Function of ABS/EBD system

ABS/EBD system

ABS control function

- ABS control system equips with independent front wheel control and unified rear wheel (low selection) control.

Description

- Low selection control: comparison of left and right wheel speed and then control the system with brake fluid pressure that most likely to lock the wheels.

EBD control function

- EBD control device equips with independent front and rear wheel control system, regardless of vehicle load (the number of passengers), it can continuously correct distribution of the brake fluid.

3.1 ABS/EBD system composition

ABS/EBD system is composed by parts as below:

- ABS wheel speed sensors (four)
- ABS / the EBD regulator and the control module assembly
- Instruments combination (CAN BUS)
- Engine ECM (CAN BUS)
- Diagnostic connector (CAN BUS)



ABS/EBD system parts location

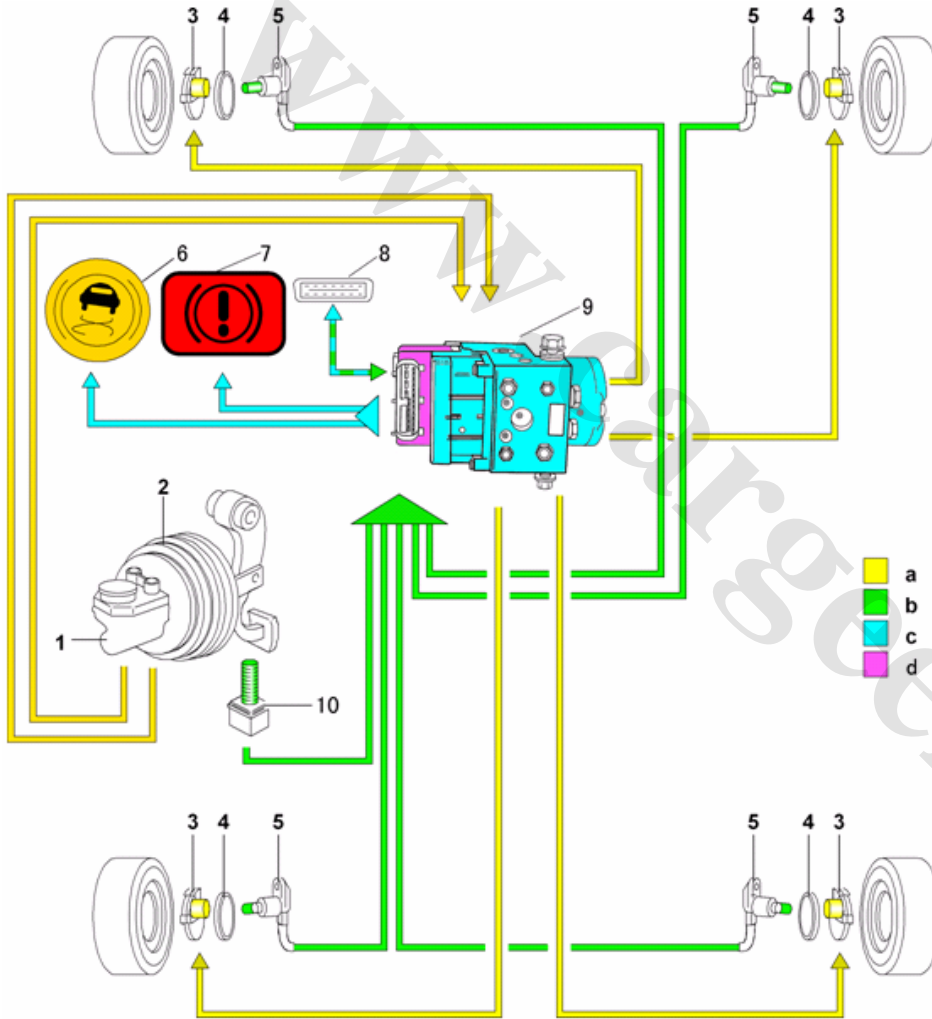

- 1 Brake master cylinder
- 2 Brake vacuum booster drum
- 3 Brake slave cylinder
- 4 ABS sensor ring gear
- 5 ABS Sensor
- 6 ABS warning light
- 7 Brake fluid level light
- 8 Diagnosis seat
- 9. ABS hydraulic control assembly
- 10 Brake switch

3.2 ABS system hydraulic circuit schematic

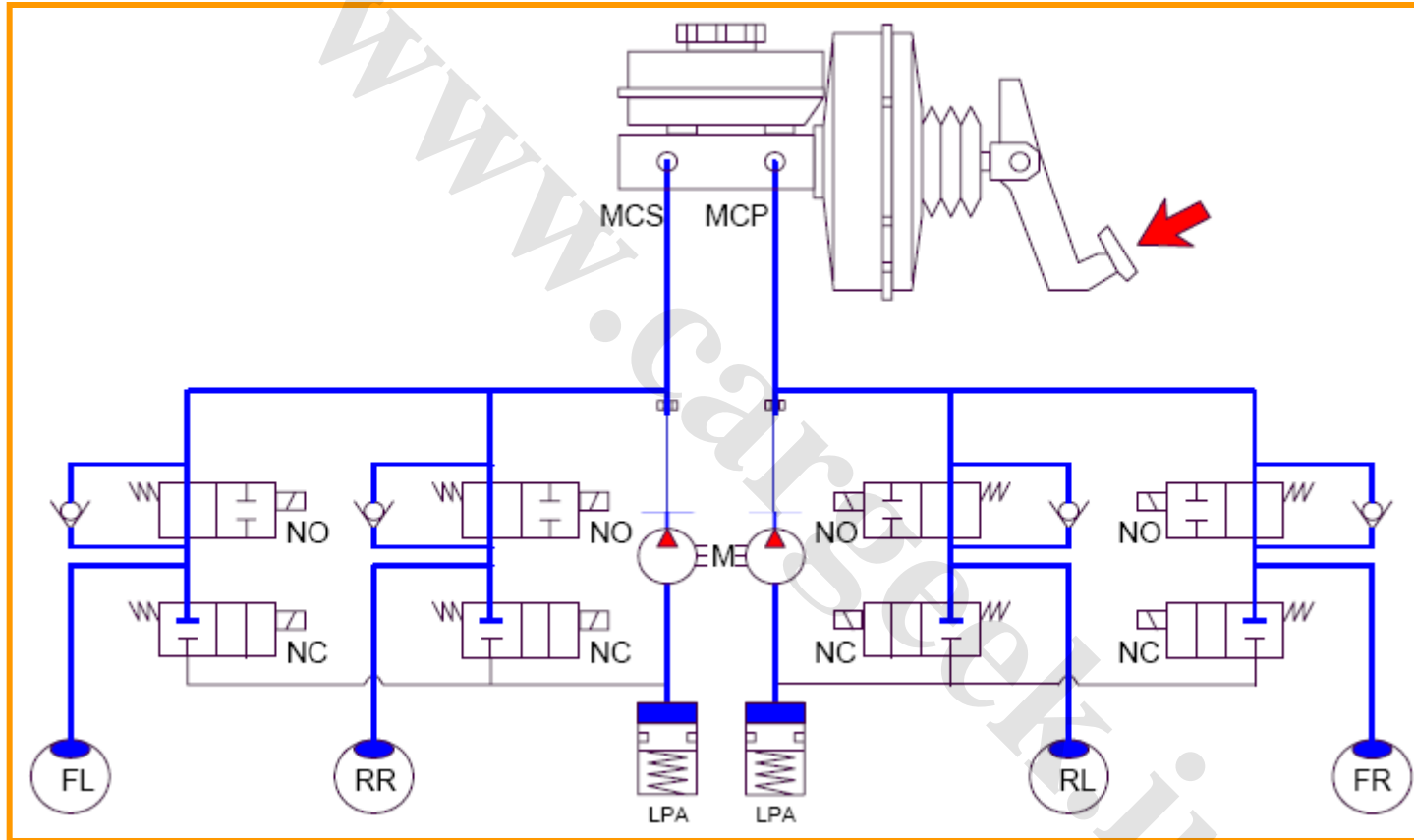

NO——Normal open valve

NC——Normal close valve

LPA——low pressure accumulator

HPA——high pressure accumulator

FL、RR、RL、FR——Refers to the front left , rear right , rear left and front right wheel cylinder

3.3 ABS system structure

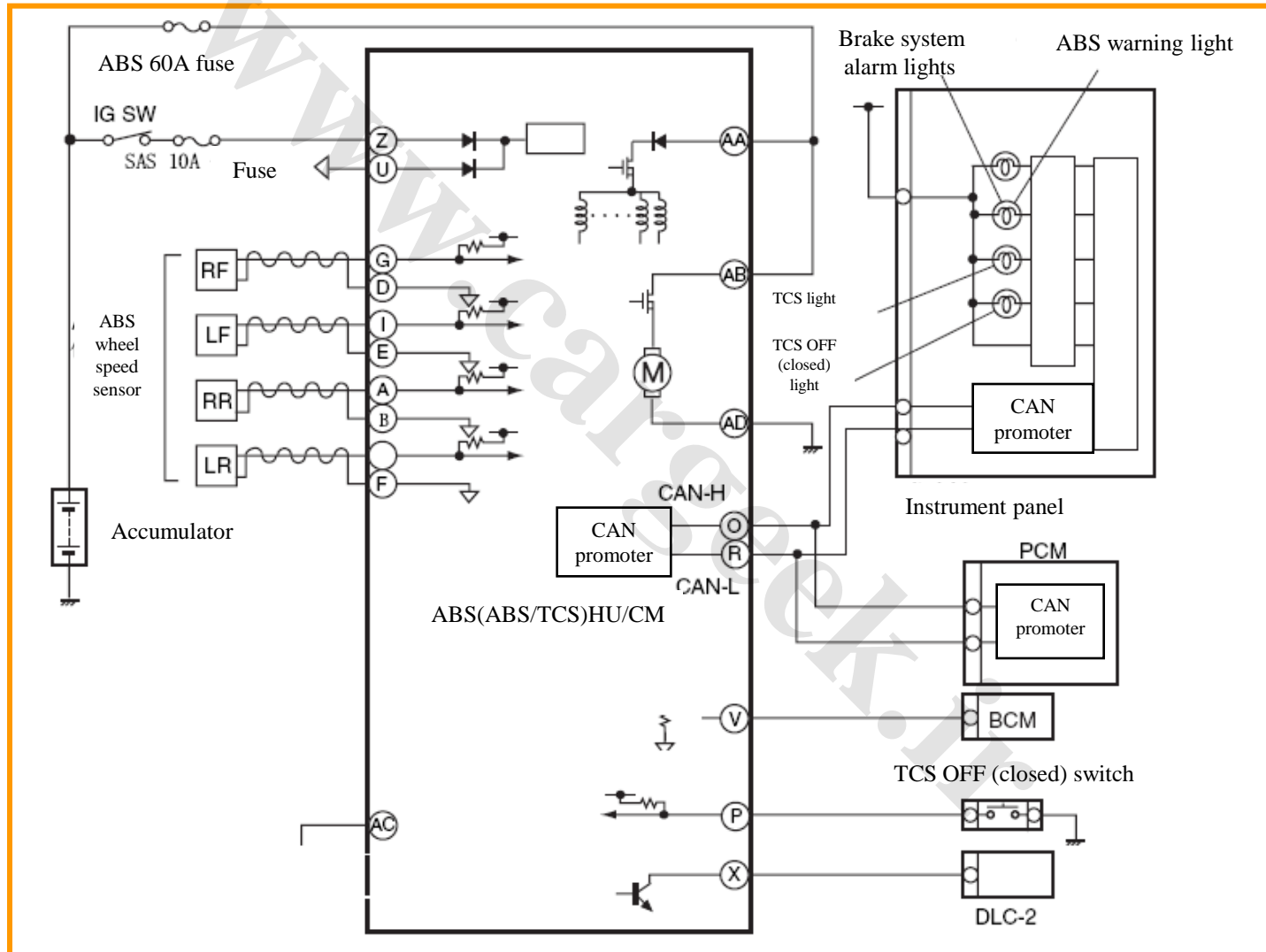

3.4 ABS/DSC regulator and the control module assembly

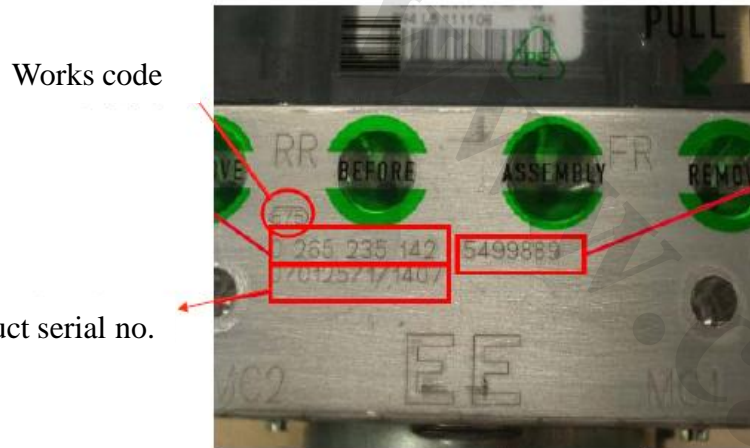

Location: front side of engine compartment
left side suspension bearing

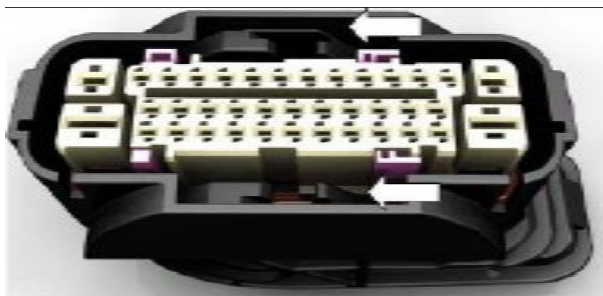

ABS control module plug-in board

Regulator function:

- Accept instructions from the control module to control each solenoid valve, then realize complete control functions of ABS / EBD / DSC;
- Internal structure and components are different for regulator equipped with ABS and DSC system.

Control module role:

- Accept signals from sensors and other input modules, then determine the extent of ABS/EBD/DSC intervention, and finally send the intervention instructions to the regulator;
- Realize real-time detection of the entire system and store the test results and fault code in internal memory;
- Realize data exchange with other electronic control modules through CAN BUS network;
- realize testing and data analysis through diagnostic equipment.

Exploded view of hydraulic controlled HCU assembly:

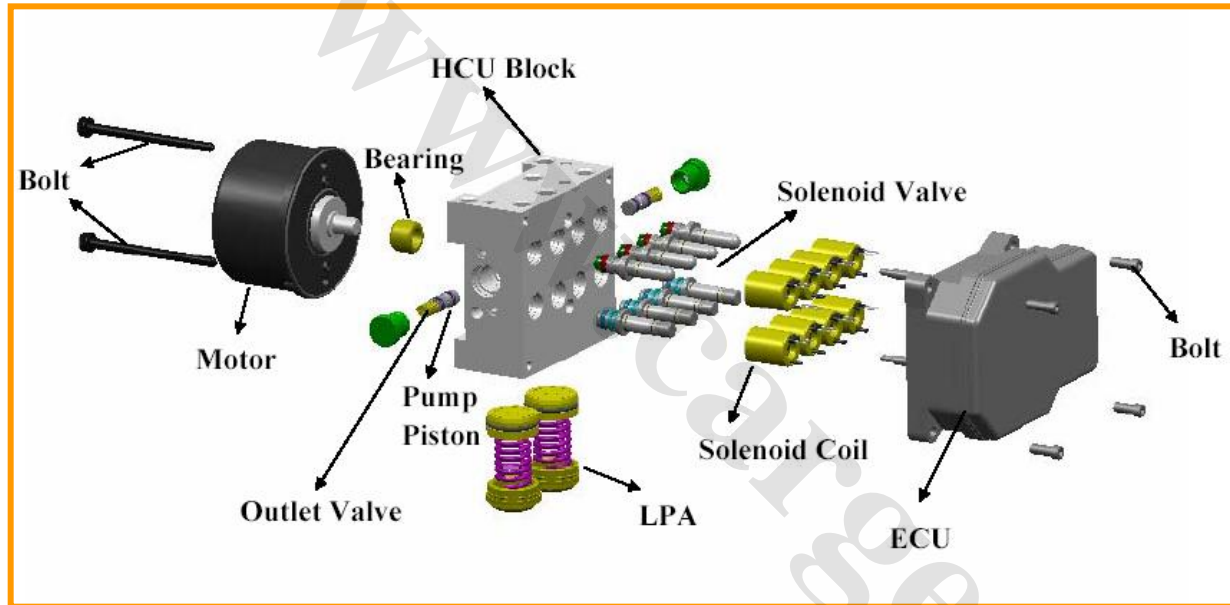

Exploded view of ABS controller assembly

3.5 Wheel speed sensor

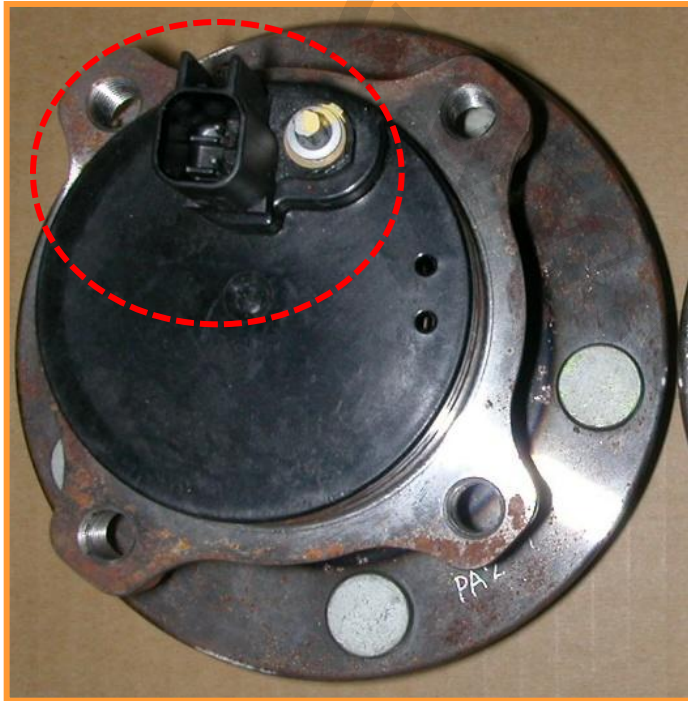

Wheel speed sensor position

Location: Install at the steering knuckle

Role: supply wheel speed signal to the control module

How it works: reluctance principle

Connect to the module through wires, it is common in the ABS / DSC system.

Active vehicle speed sensor

Active vehicle speed sensor uses a Hall IC instead of traditional coil and guide bar magnet parts.

Active wheel speed sensors

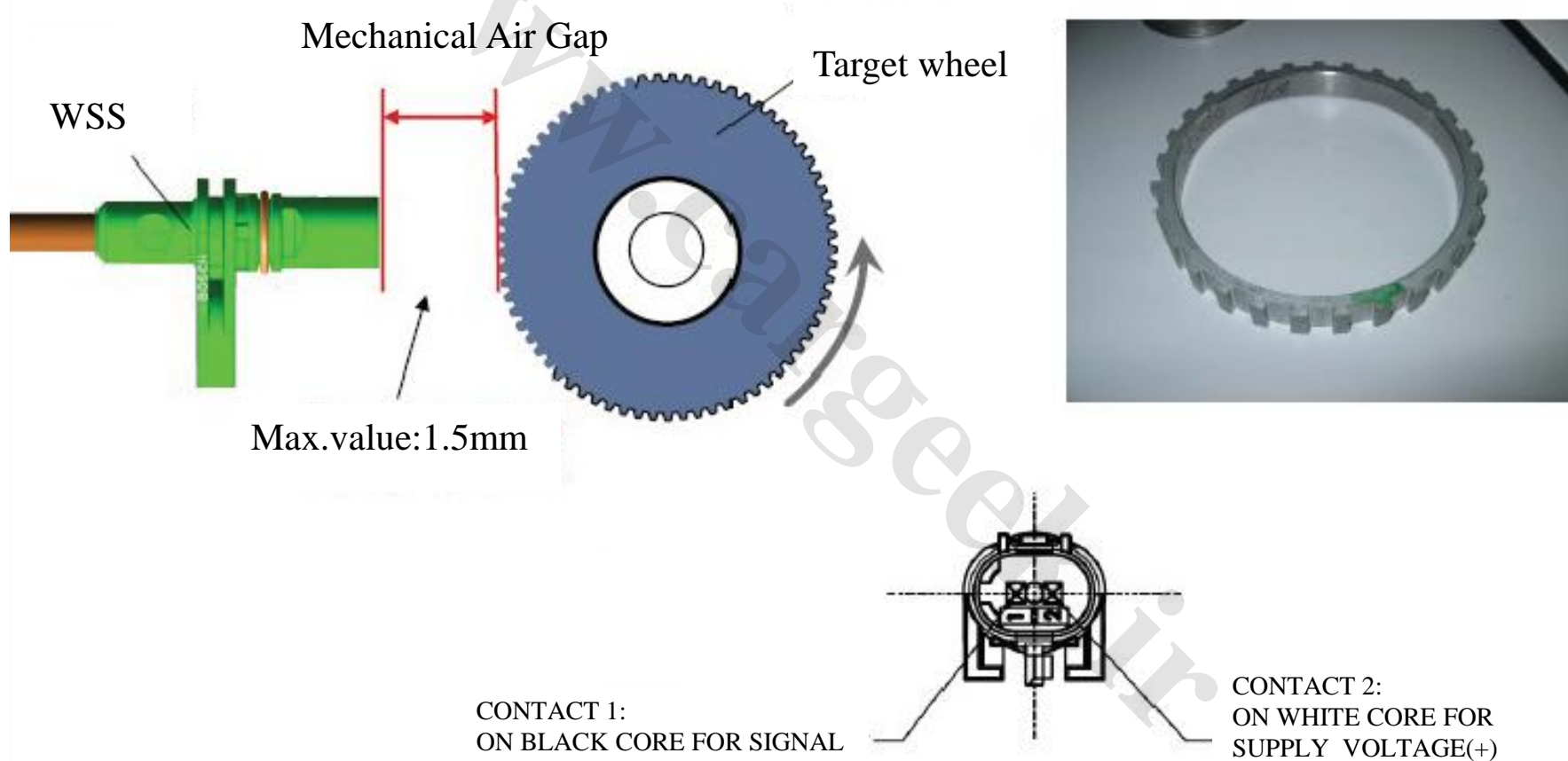

Active wheel speed sensor

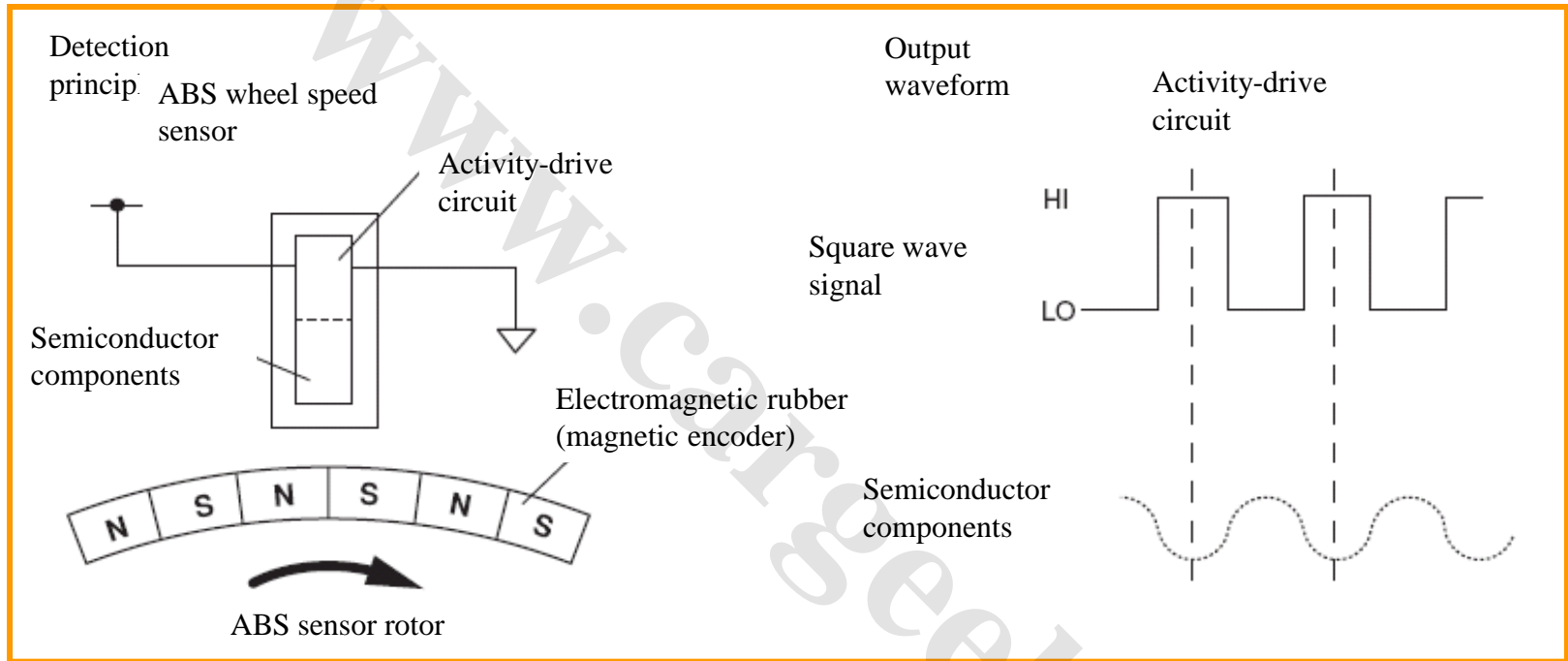

Note: Check the ABS wheel speed sensor , do not use the tester to check resistance . Voltage from the tester may damage the semiconductor within the ABS wheel speed sensor . Please use the WDS or equivalent device PID data monitor device to check

3.6 Circuit analysis

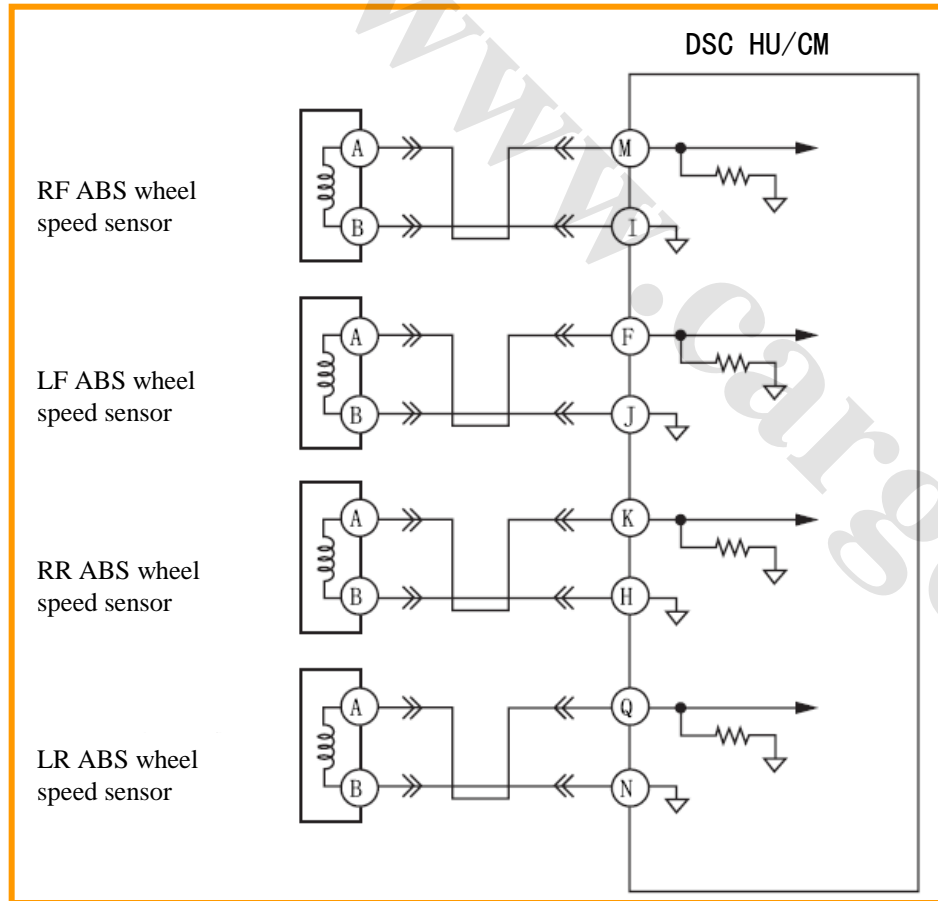

Fault phenomenon: fault lights , system halted .

Diagnostic methods : diagnostic apparatus

Front view

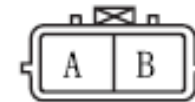

Rear view

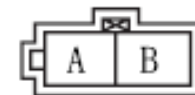

1 # : sensor signal+

2 # : sensor signal-

3.7 Set for replaced B50 ABS hydraulic assembly

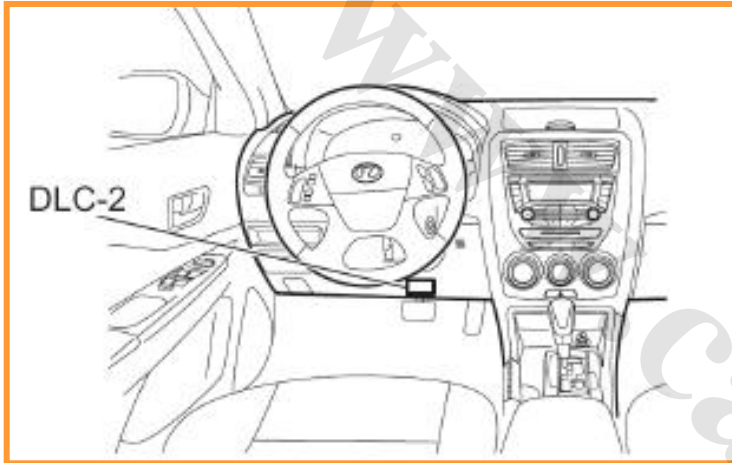

- It must be set after replace of the ABS, otherwise, the ABS may not work correctly
 - Connect the F-ADS diagnostic equipment to DLC-2.
 - Select V11.02 Edition diagnostics software and enter the "system scan".
 - Select "Module Programming".
 - Select the auto-configuration module.
 - Select "ABS", and program execution according to the prompts on the screen.
 - Retrieve the DTC through F-ADS diagnostic equipment, check and confirm the DTC appears.
 - If DTC takes place, implement relevant DTC check.

www.cargeek.ir

Thank you !

奔腾 BESTURN

Technical Training of BESTURN B50

— Vehicle Steering Adjustment and Control

奔腾 BESTURN

Suitable post: Technical director

Curriculum Goals

- Master maintenance and inspection of the steering system
- Understand basic structure of the steering system
- Understand basic principles of the power steering

Contents

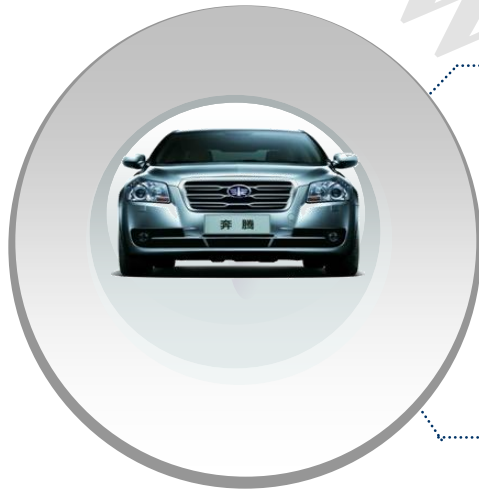

1. Parameters and maintenance of the steering system

2. Structure of the steering system

3. Introduction of main components of the power steering

1. Parameters and Maintenance of the Steering System

1.1 Parameters of the Steering Technology

Items		Technical specifications	
Steering wheel	External diameter (mm)	372	
	Total number of rotation turns (number of turns)	2.75	
Steering gear and steering transmission mechanism	Type	Rack and pinion steering gear	
	Rack stroke (mm)	146.8—148.8	
Steering performance	Steering shaft type	Compressible	
	Connection type	Cardan joint connection	
	Angle regulating variable (mm)	45	
	Compression regulating variable (mm)	50	
Power steering system	Auxiliary power type		
	Power steering fluid	Type	Sensitivity type M-III or other equivalent devices (e.g. Dexron II)
		Liquid volume *(approximate quantity) (L)	0. 80L (MT) 0. 87L (AT)

1. Parameters and Maintenance of the Steering System

www.CarGeek.ir



1.2 Inspection of the Power Steering Fluid



➤ Inspection of the Liquid Level

Inspect the liquid level of the power steering fluid. It is necessary to add the fluid to the specified liquid level.

Types of the Power Steering Fluid

ATF M- III or other equivalent devices (e.g. Dexron II)

Volume of the power steering fluid (approximate value)

2WD MTX (LF, L3) : 0.80 L

2WD ATX (LF, L3) : 0.87 L

1. Parameters and Maintenance of the Steering System

www.CarGeek.ir



1.3 Inspection of the Steering Wheel and Steering Column

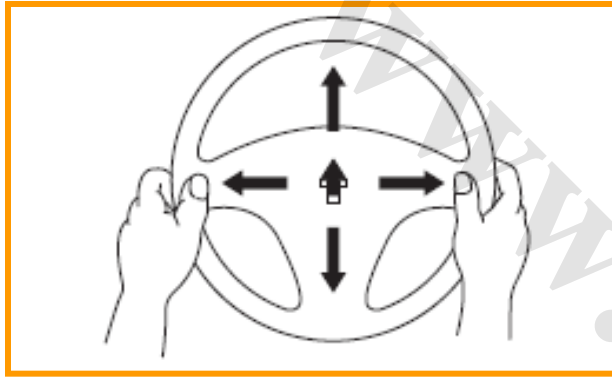

➤ Hand Power Inspection of the Steering Wheel

1. Start the engine, and preheat the power steering fluid to 50-60°C
2. Measure the hand power of the steering wheel with torque spanner
 - If it is not within the specified scope, the following items should be confirmed:
 - There is no air in the steering system
 - There is no leakage at hose or joint
 - Oil pump and steering gear works normally
3. Steering wheel hand power 7.8 N.m max.

➤ Free Clearance Inspection of the Steering Wheel

- Set right the wheel, gently rotate the steering wheel towards left and right, and confirm if the free clearance meets the technological requirements.
- In the event that the free clearance exceeds the specified scope, possibly because of the abrasion of the steering shaft cardan joint or the over-sized gear backlash of the steering gear, which must be corrected.
- Free clearance of the steering wheel is 0-30mm

1. Steering system Parameters and maintenance

www.CarGeek.ir



1.4 Inspection of the Power Steering Fluid Pressure

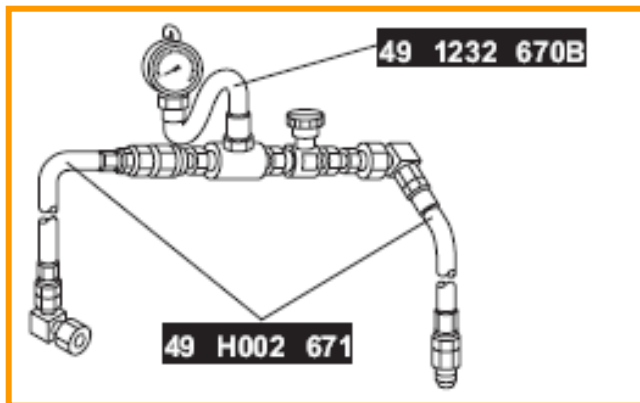
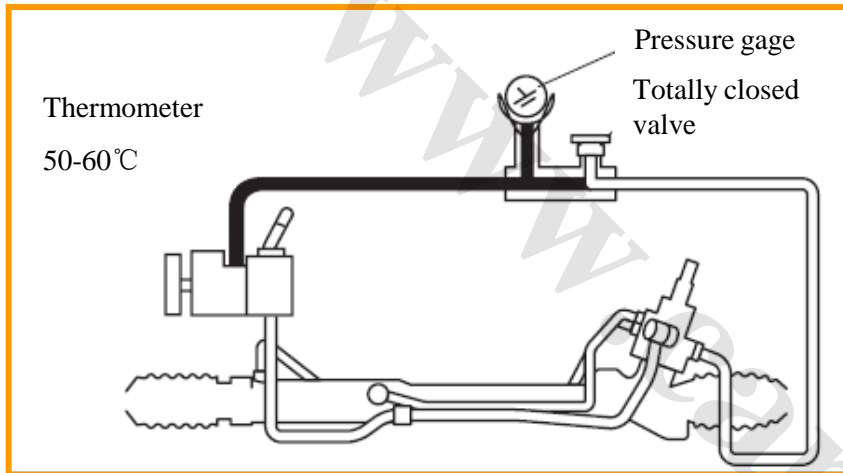

- Assemble special service tools as the figure shows
Take apart the high-pressure oil pipe from the steering oil pump to connect special service tools, thus, air can be discharged from the system.
- Totally open the valve
Start the engine and rotate the steering wheel to left and right dead center position, raise the liquid temperature to 50—60 °C..
- Totally close the valve.
Increase engine rotation speed to 1000-1500 rpm and measure the pressure produced by oil pump.
- Oil pump hydraulic pressure
10.80—11.29 (Mpa)

2.1 Basic Adjustment of the Steering Column

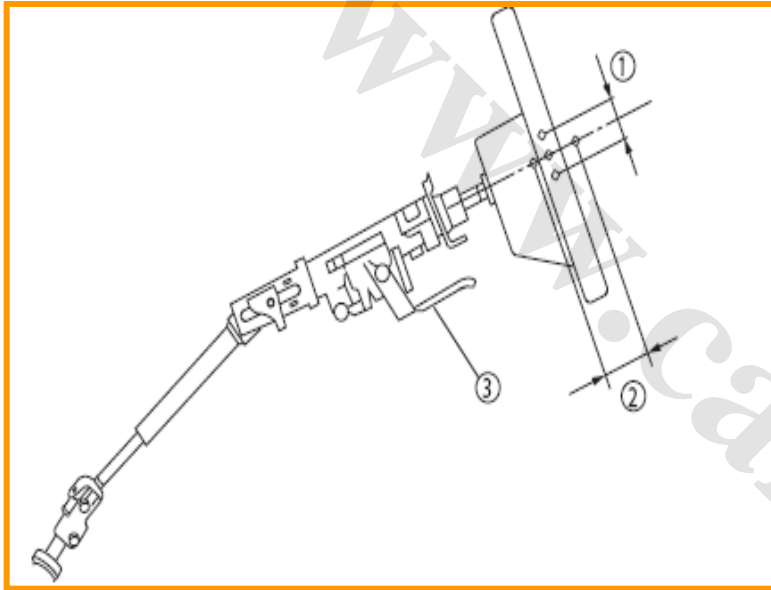

1. Angle regulating variable 45mm
2. Height regulating variable 50mm
3. Angle/height position adjusting handle

- Take the move of engine and steering system components into consideration when the vehicle suffers from serious strike, the steering column is thus a collapsible mechanism. The underpart of steering column is flexible, and the steering column is installed to the girder of instrument board.
- Gradient of the steering wheel is adjustable up and down.
- Horn switch, entertainment control switch and cruise control switch are installed to the steering wheel.
- All switches are connected with rotating coupler joint through connecting line.
- The airbag located at the center of steering wheel and under plastic cap provides protection for the face and upper body of the driver.

2.2 Structure/Operation of the Engine-Absorbing System

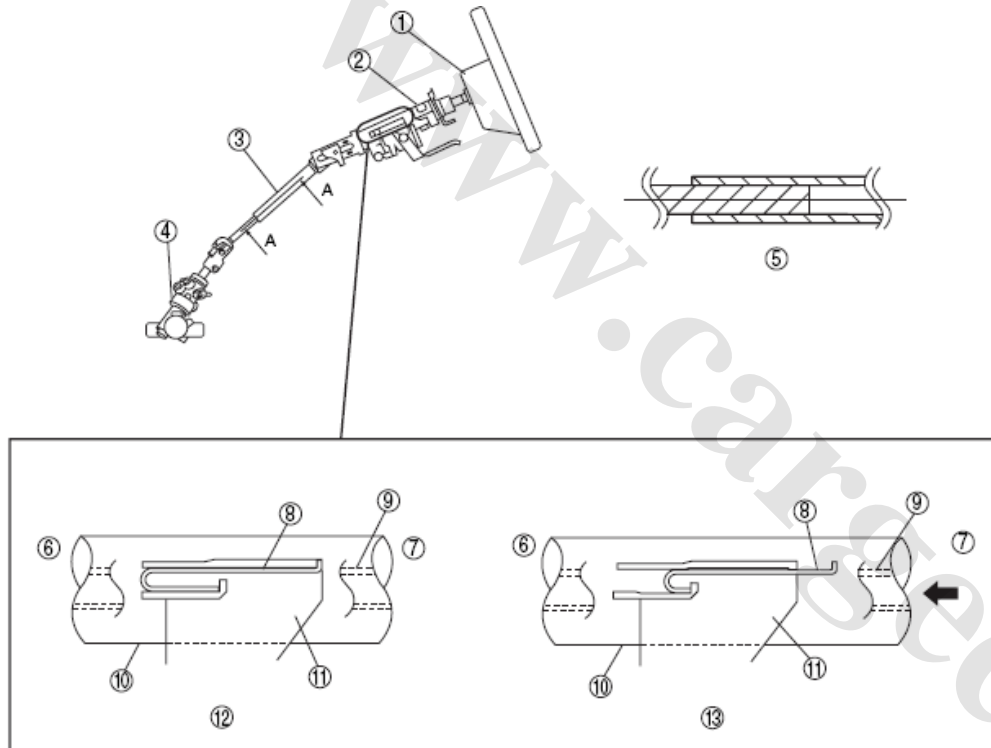

Work Principles: steering gear is connected with steering shaft through intermediate shaft, when collapse occurs, steering gear shall move backwards and intermediate shaft shall be compressed, thus, the harm to driver caused by steering shaft is avoided, that is to say, when the body of driver strikes onto the steering wheel, the force on steering wheel shall be passed to the inner shaft, outer pipe column and fixed support, until the support disconnects with instrument board, and the whole steering shaft shall move forward, meanwhile, one end is fixed to instrument board, the U template with the other end fixed with the fixed support shall deform, thus, striking energy is absorbed and the harm to driver is more reduced .

2.3 Gear-Rack Power steering gear

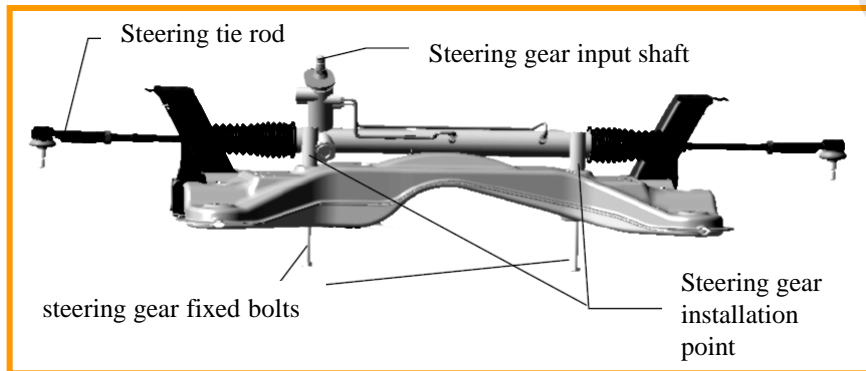
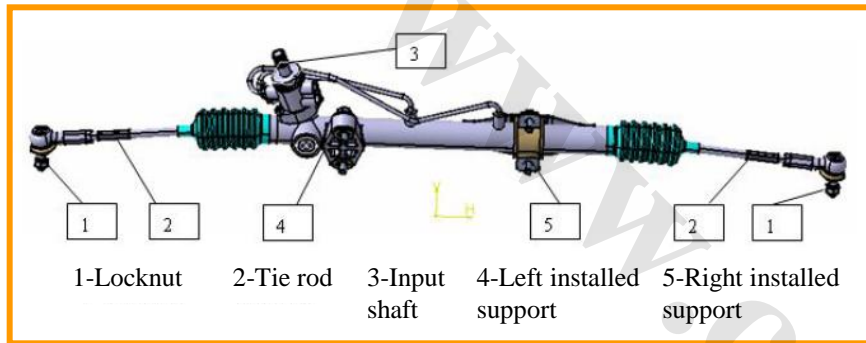

- Power steering gear is installed to a proper position under rear cross beam of front auxiliary carframe.
- As the installation point of power steering gear and suspension rotation fulcrum are both determined by the rigid front auxiliary carframe processed by precision machine, so at any time, relative design physical dimension relation between steering pinion rack mechanism and suspension can be kept.
- Rigid connection between steering gear and carframe ensures the reliability of steering system.
- Steering gear oil inlet and outlet fastening torque: $30 \pm 3\text{Nm}$
- When adjusting front wheel toe in, tie rod lock nut fastening torque: 20-25Nm
- Steering gear and steering knuckle connection tightening torque: $25 \pm 5\text{Nm}$
- Steering gear and auxiliary carframe connection tightening torque: $100 \pm 10\text{Nm}$

2. Structure of the Steering System

2.4 Adjustment of the Steering Gear Clearance

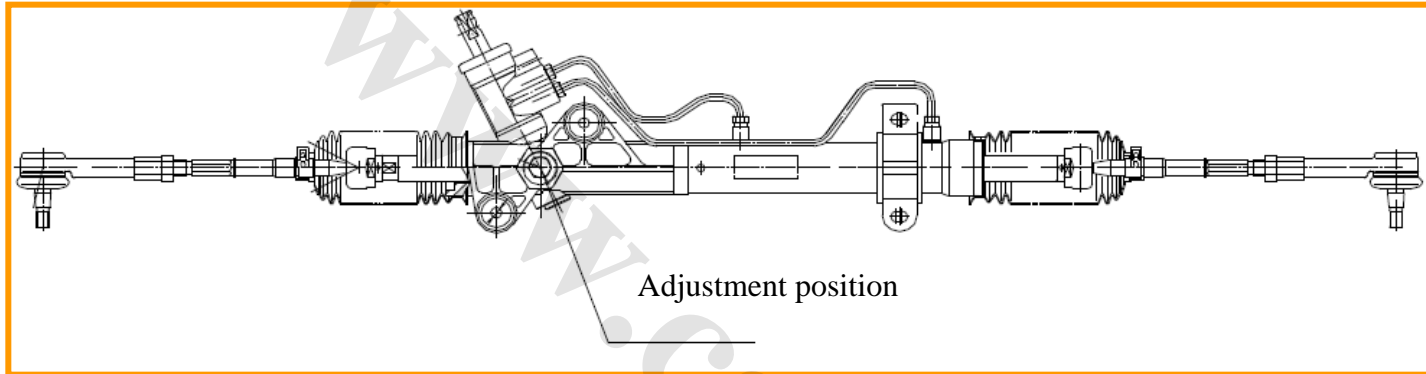

Hints:

Before delivery, steering gear has been adjusted in the factory, so it does not require for adjustment in general conditions.

- If the steering clearance is too large, the phenomenon of direction instability shall occur, affecting driving safety.
- If the steering clearance is too small, and return of the steering wheel is poor, the arms of the driver shall become fatigue easily, affecting driving safety.

2. Structure of the Steering System

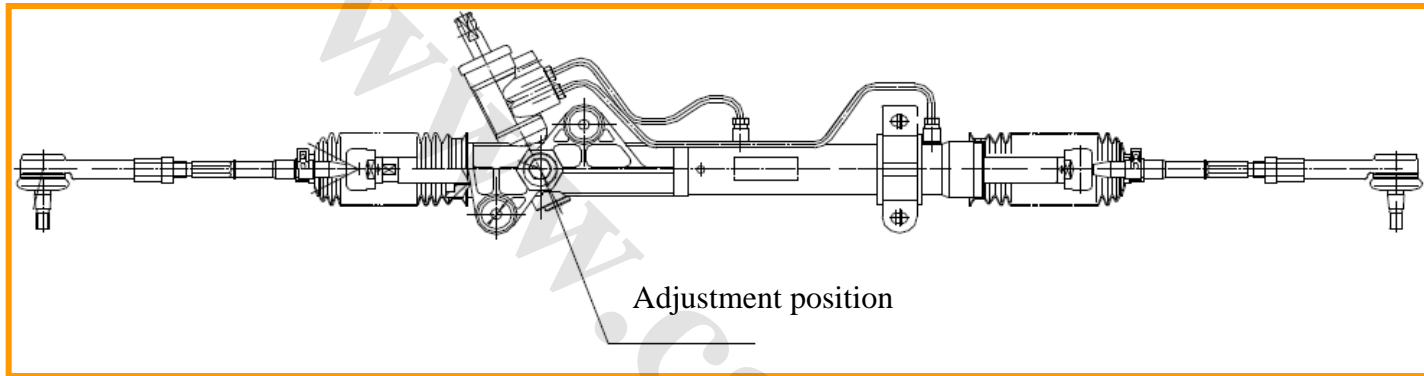

Clearance Adjustment Steps of the Steering Gear

Step 1: locate wheel at the position of straight driving.

Step 2: rotate steering wheel towards both sides.

Step 3: if steering gear makes a noise, adjust the screw according to the figure, until striking noise cannot be heard when rotating steering wheel.

Step 4: retighten the screw 1/8 circle (about 45°).

Step 5: road test.

Step 6: if the rotating mechanism can not return back to the central position automatically, loose screw to 15° .

Step 7: road test.

3. Introduction of Main components of the Power Steering

www.CarGeek.ir



3.1 Basic Structure of the Power Steering System

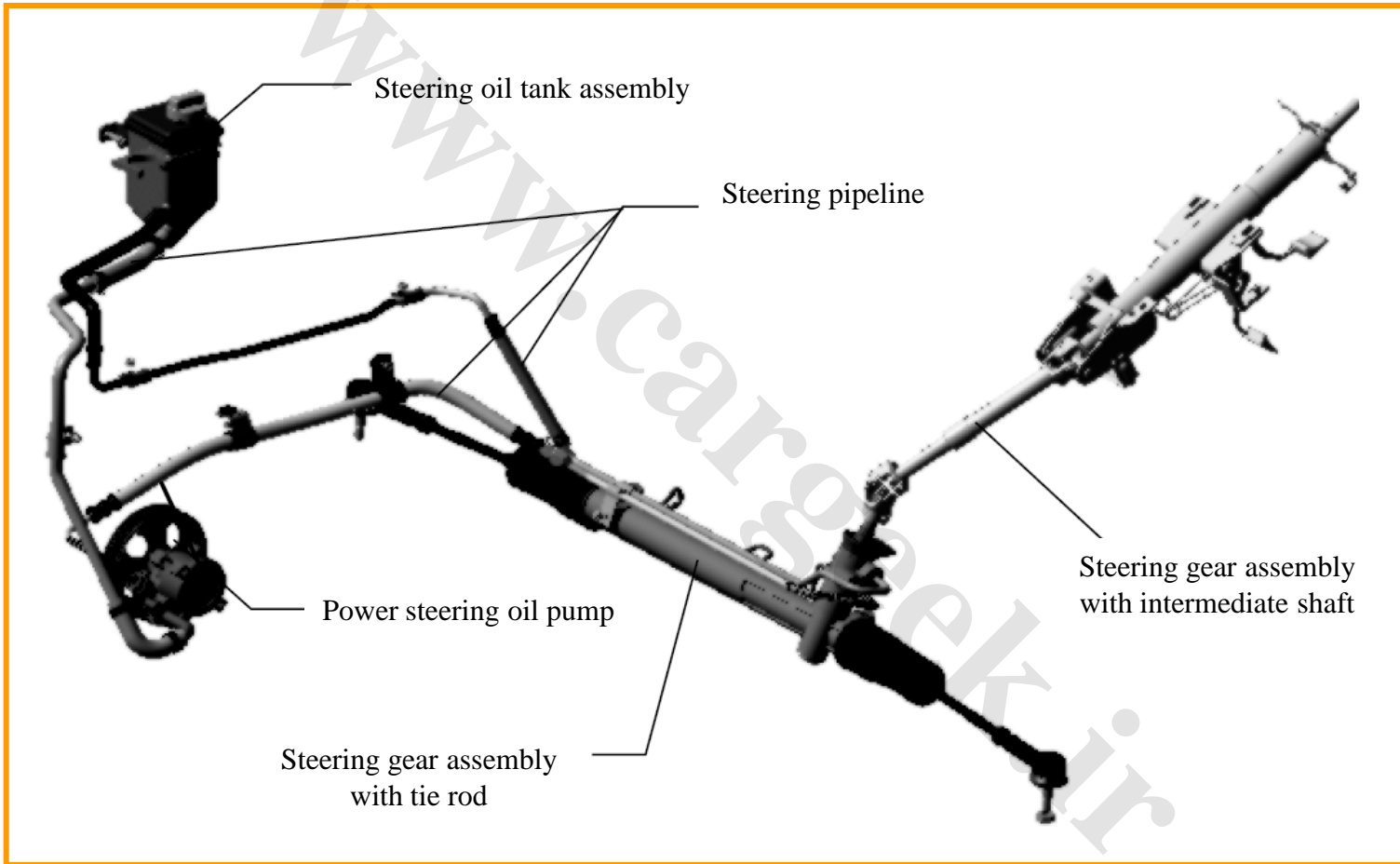

3. Introduction of Main components of the Power Steering

www.CarGeek.ir



3.2 Steering Oil Pump

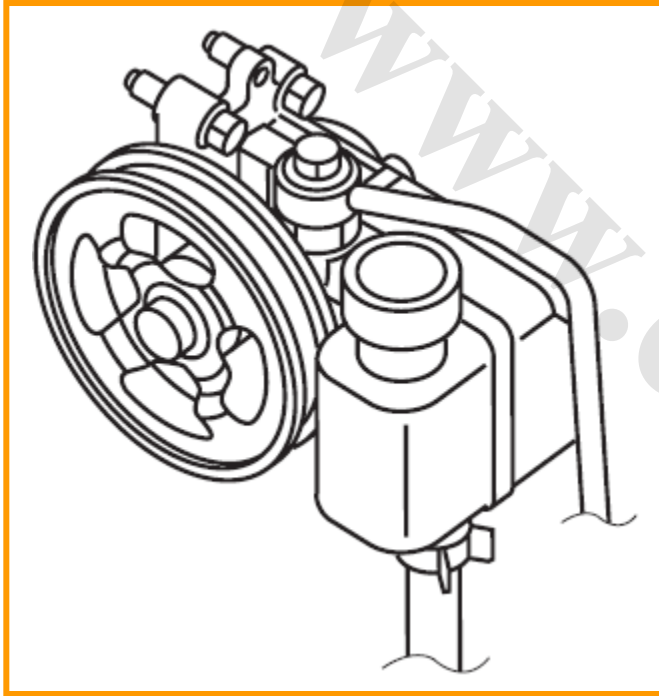

- Common vane pump is adopted
- The pressure of steering system is provided by impeller type power steering pump, and the steering pump is driven by crankshaft through steering pump belt.
- When the engine starts, hydraulic oil is absorbed out from liquid stock tank by steering pump, the quantity and pressure of delivering oil shall be adjusted by the flow control valve of steering pump, and the spare oil shall return to the inlet of oil pump through oil drain hole.

Cautions: when operating hydraulic system, please be cautious, because high pressure liquid is very hot, and when the pump is working, pressure shall exceed 10000Kpa. Careless operations will lead to personal injury.

3. Introduction of Main components of Power Steering

Working Principles of Steering Pump

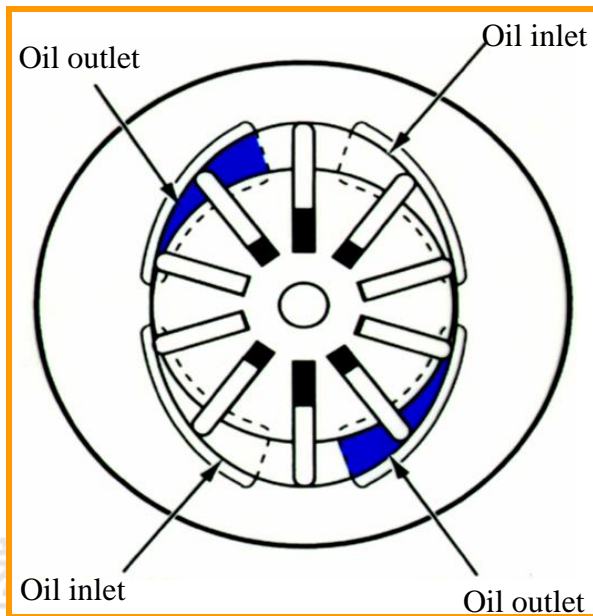
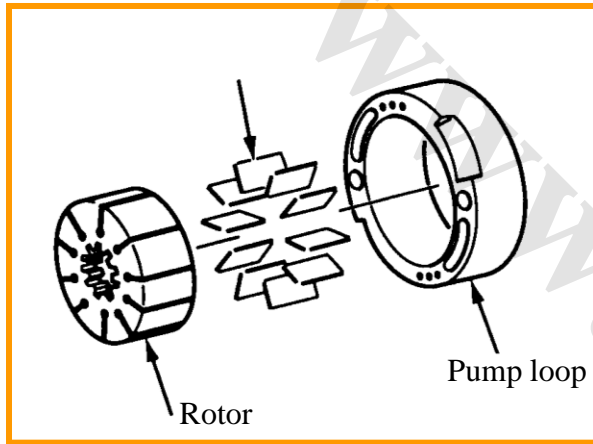

- The space formed by rotor, loop and any two adjacent blades is a single pump cavity.
- As the pump loop is ellipse, every pump cavity volume changes all the time, when blade moves through the “increase” part of loop, volume shall increase and absorb liquid through oil inlet.
- When blade moves through “reduction” part of loop, volume shall reduce, and the reduced volume makes pressure increase, forcing liquid flowing out of oil outlet.

3. Introduction of Main Components of the Power Steering

www.CarGeek.ir



3.3 Power Steering Hydraulic Circuit

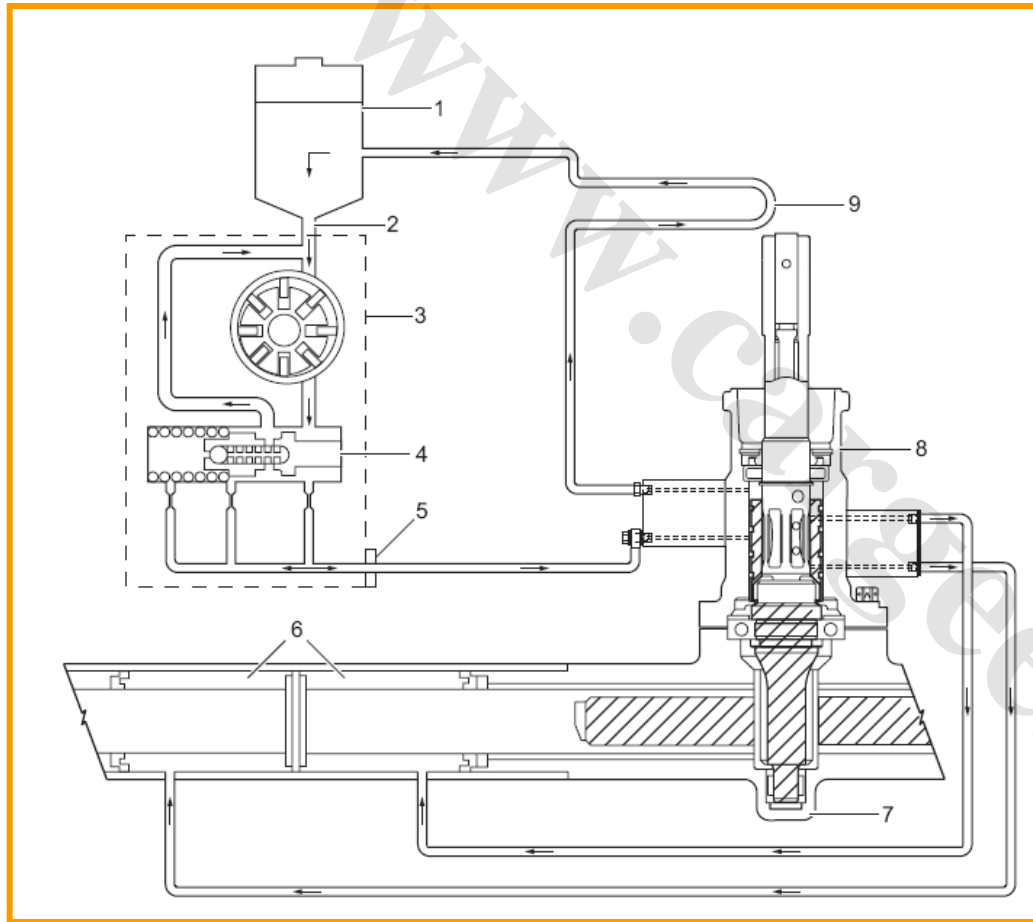

1. Steering oil tank
- 2 Low pressure oil inlet pipe
- 3 Power steering (PAS) pump
- 4 Oil outlet
- 5 Flow control/safety valve
- 6 steering gear oil tank pressure area
- 7 Steering pinion rack mechanism
- 8 Steering valve unit
- 9 Power steering oil cooling pipe

3. Introduction of Main Components of the Power Steering

Continued

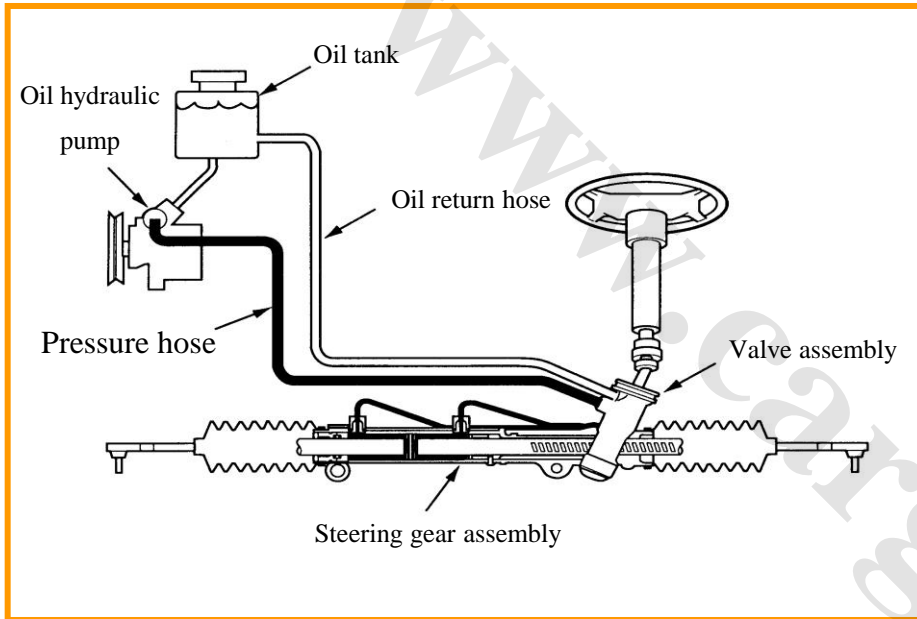

- The hydraulic pressure from power steering oil pump is delivered to steering valve through steering pinion gear, and the control valve controls hydraulic pressure and changes liquid flowing direction
- Liquid is led to the pressure cylinder on the side of steering gear, producing steering pinion-rack propelling force.
- Pressure oil liquid flows back from steering gear pressure tank through a ring passage of liquid drain pipe, before power oil liquid returns back to steering oil tank, this ring passage plays the role of cooling the power steering oil liquid.
- Steering oil tank is the place to store power-assisted oil liquid.

3. Introduction of Main Components of the Power Steering

www.CarGeek.ir



3.4 Working Principles of the Flow Control Valve

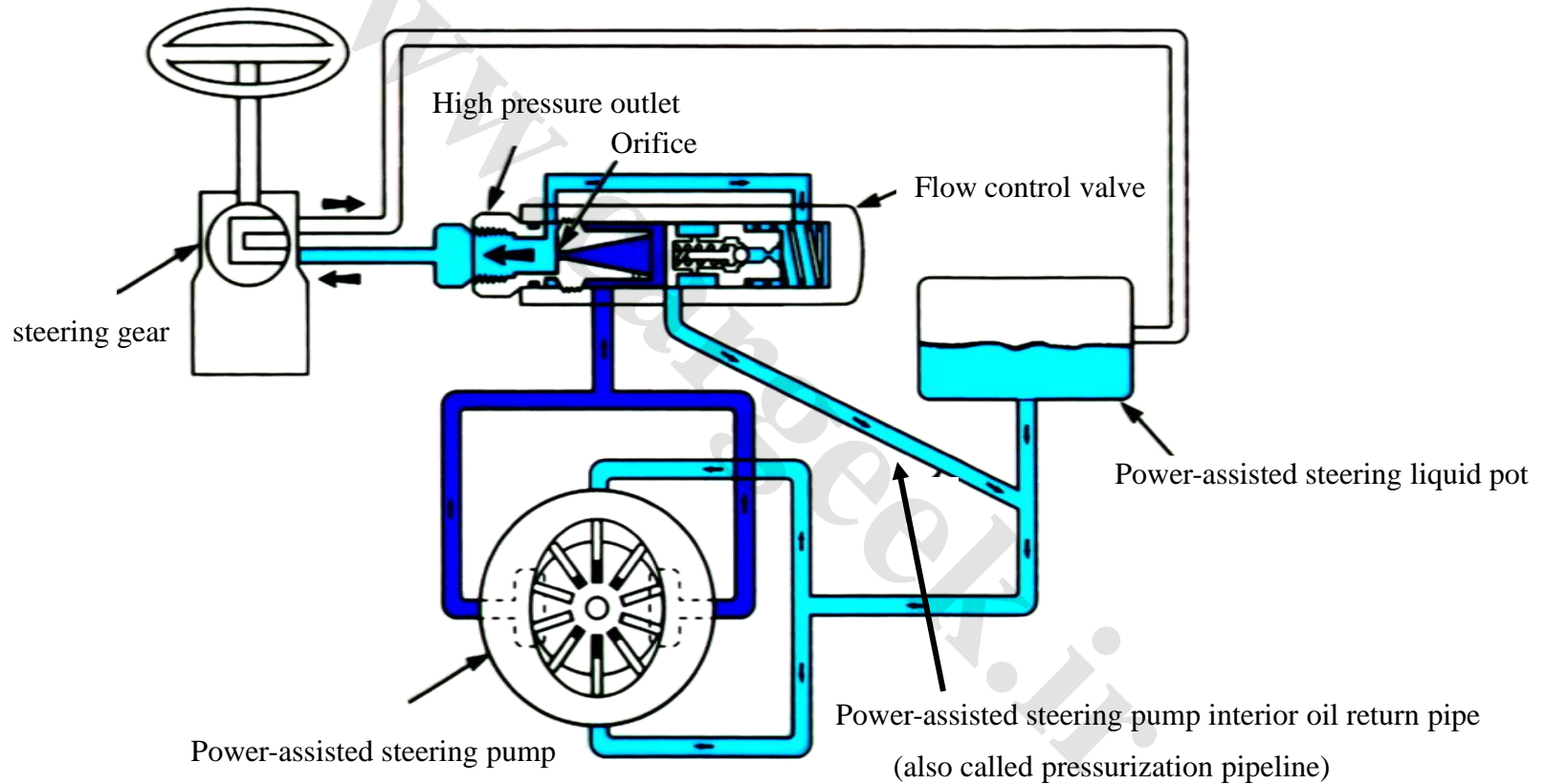

3. Introduction of Main Components of the Power Steering

- After the engine is started, power steering oil pump absorbs the power-assisted oil liquid of oil tank to the low pressure oil inlet pipe, flowing through steering power pump, the power-assisted oil liquid shall be changed into high pressure oil liquid at oil outlet, and the high pressure oil liquid reaches steering valve through a high pressure oil pipe.
- If steering force is not exerted, the pressures at both sides of steering gear oil tank piston are equal, and the rest oil liquid returns back to oil tank through steering valve and power steering oil cooling pipe.
- If steering force is exerted towards any side, oil liquid pressure shall be led to the side of steering gear oil tank piston, providing power-assisted steering force and reducing required steering force.
- Discharged steering power oil liquid because of steering gear oil tank piston movement flows from steering valve, through power steering oil cooling pipe, back to oil tank.
- Power steering oil cooling pipe reduces the temperature of power-assisted oil liquid, and prolongs the service life of hose and sealing elements in the system.

Thank you!

奔腾 BESTURN

Technical Training of BESTURN B50

Power supply distribution circuit diagram

奔腾 BESTURN

Suitable post: Technical chief

Curriculum Goals

- To understand basic information about the car body electrical system
- To master the reading method of the circuit diagram
- To understand basic connection functions of CAN and its features
- To understand basic functions of BCM

Contents



1. Illustration of the circuit diagram







2. Basic illustration of power supply distribution

3. Communication data bus

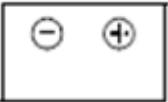
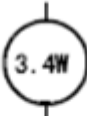
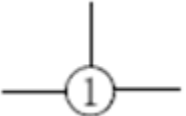
4. Car body control module BCM



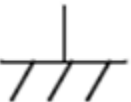





1. Illustration of the circuit diagram

1.1 Illustration of symbols in the circuit diagram

Symbol	Signification	Symbol	Signification
Battery 	<ul style="list-style-type: none"> ● Generate the electricity through chemical reactions ● Providing direct current for the circuit 	Lighting burner 	<ul style="list-style-type: none"> ● When current flows through the filament, it will glow and emit heat.
ground (1) 	<ul style="list-style-type: none"> ● If current flows from the positive electrode of the battery to the negative electrode, connect the point to the car body or other ground lead. ● ground (1) shows the connection of one ground point to the ground electrode via the harness. ● ground(2) shows the ground point, i.e. the component is directly connected to the ground electrode. Note <ul style="list-style-type: none"> ● If ground is failed, the current will not flow through one circuit. 		
ground (2) 		Resistor 	<ul style="list-style-type: none"> ● One resistor with constant resistance. ● Mainly used to protect electrical components in the circuit by maintaining the rated voltage.
ground (3) 		Electric Motors 	<ul style="list-style-type: none"> ● Change electric energy into mechanical energy.

1. Illustration of the circuit diagram

1.2 Harness symbols and lead connection colors

Name of electrical wiring	Symbol	Name of electrical wiring	Symbol
Electrical wiring at front end	(F) 	Electrical wiring at front left door	(DR1)
Electrical wiring of the engine	(E) 	Electrical wiring at front right door	(DR2)
Electrical wiring of front wall	(D) 	Electrical wiring of rear left door	(DR3)
Rear electrical wiring	(R) 	Electrical wiring of rear right door	(DR4)
Rear electrical wiring No. 2	(R2)	Electrical wiring of rear windshield defroster	(SH1)
Electrical wiring of the instrument panel	(I) 	Makeup illumination electrical wiring	(SH2)
Ejecting electrical wiring	(INJ) 	Electrical wiring at front left door switch	(SH3)
Electrical wiring of internal illuminating lamps	(IN) 	Electrical wiring of auxiliary instrument panel	(SH4)
Electrical wiring of front fog light	(FF) 	Electrical wiring of front windshield washing nozzles	(SH5)

Color	Code	Color	Code
Black	B	Orange	O
Blue	L	Pink	P
Brown	BR	Red	R
Navy blue	DL	Sky Blue	SB
Dark green	DG	Tan	T
Grey	GY	Purple	V
Green	G	White	W
Light blue	LB	Yellow	Y
Light green	LG		

1.3 Sign illustration in the circuit diagram

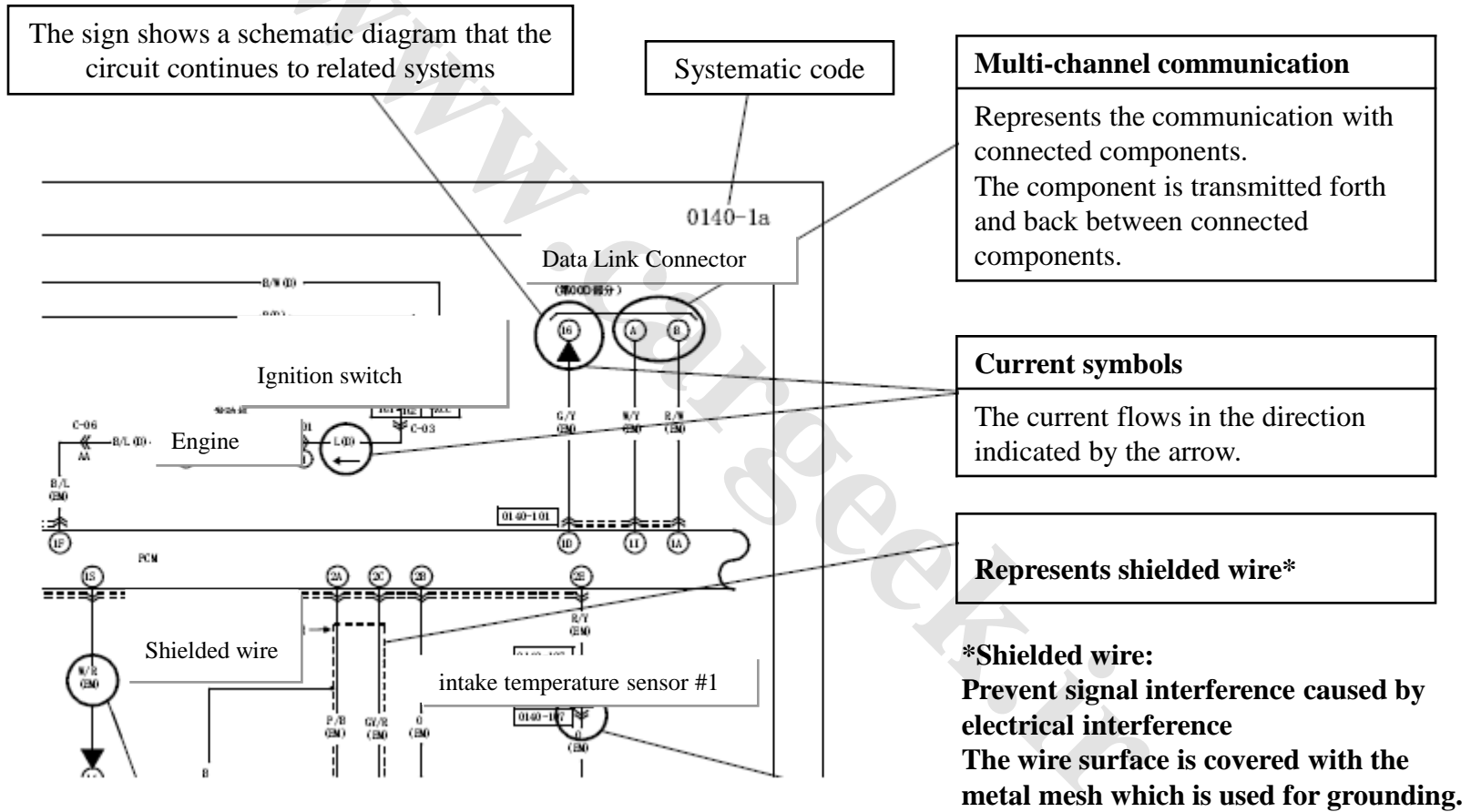

1. Illustration of the circuit diagram

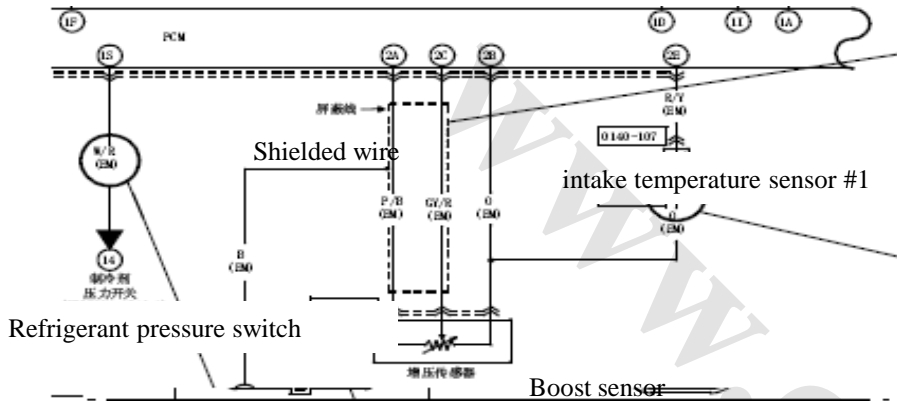

Represents the shield wire *

Connector symbol

In the circuit diagram and the connector schematic diagram, female and male connectors are indicated by the following symbols.

		Symbols in the circuit diagram	Symbols in the connection schematic diagram
Male connector			
Female connector			

- Double-color wire is indicated by a sign consisting of two letters. The first letter represents the base color of the wire and the second letter represents the color of the stripe. For example:
W/R represents a white wire with red stripes.
BR/Y represents a brown wire with yellow stripes

Symbol (example)

	Pure color wire		Wire with stripes
	Black		White (base color) Red (stripes)

- According to the specification of electrical wiring signs, they shall be indicated in the parentheses .

- Identical connectors are connected with a short line between the connector symbols.
- The connector schematic diagram shows the connectors at the side of electrical wiring. Terminals represent the schematic diagram at the side of electrical wiring.

Connector at the side of electrical wiring

- The color of the connector except white shall be indicated in its position.
- Unused terminals shall be indicated by *.

2. Basic illustration of power supply distribution

www.CarGeek.ir



2.1 Illustration of fuse and relay box

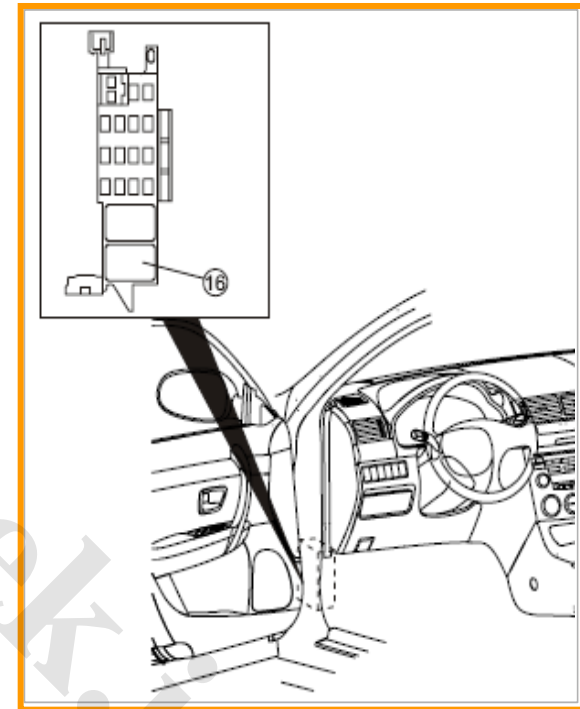
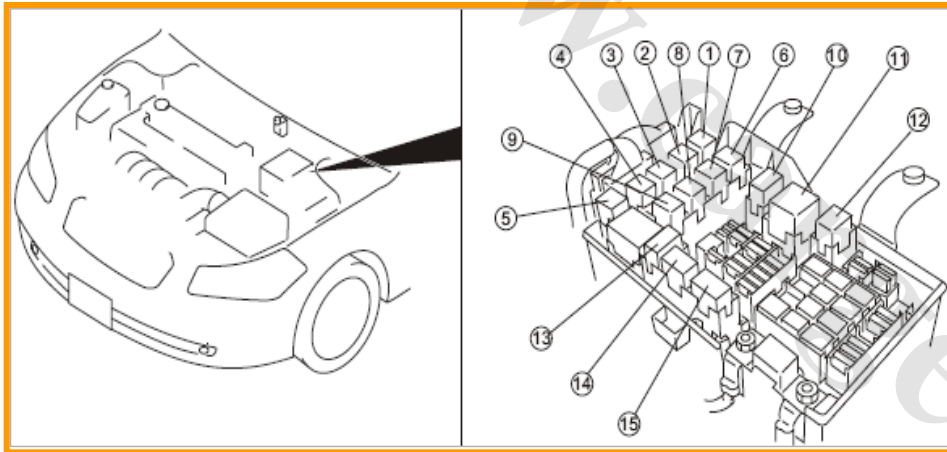

2. Basic illustration of power supply distribution

www.CarGeek.ir



2.1 Illustration of fuse and relay box



Front hood fuse and relay box



Instrument fuse box

2. Basic illustration of power supply distribution

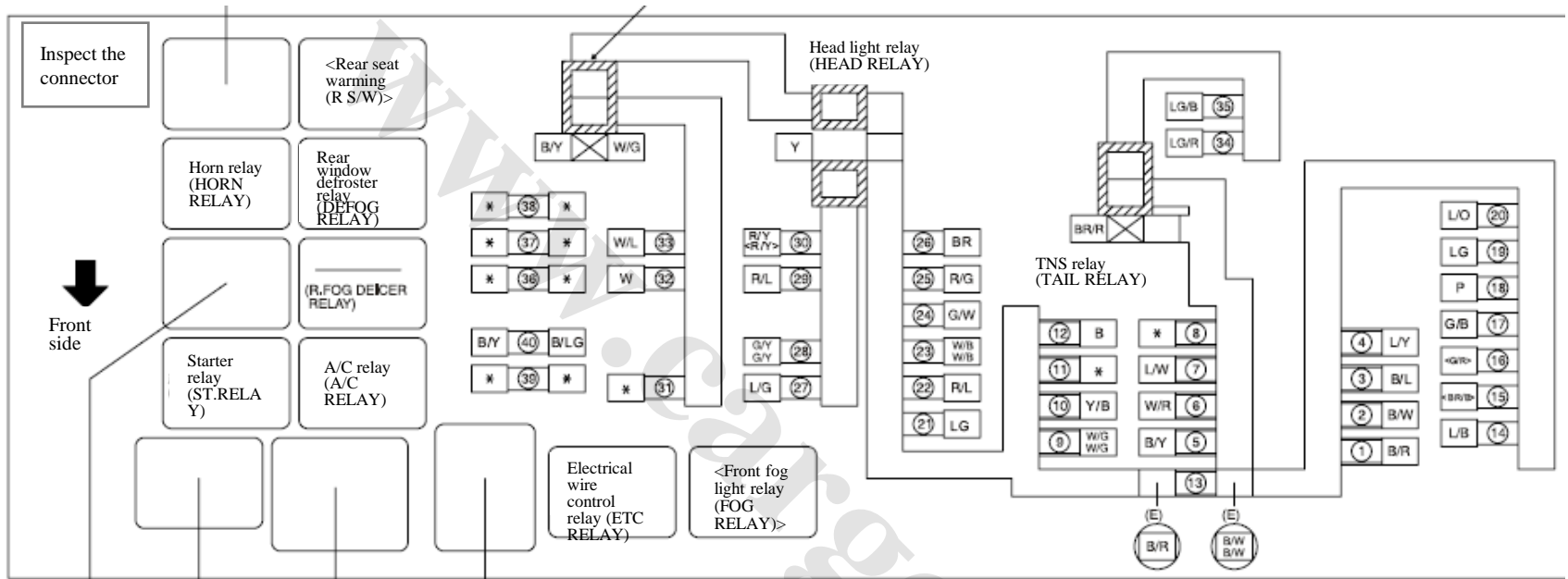

Additional cooling fan motor relay No. 3 (AD FAN#3 RELAY)

At a frequency electrical AT MIN PELAY

Cooling fan motor relay No. 2 (FAN#2 RELAY)

Additional cooling fan motor relay No. 1 (AD FAN RELAY)

① FAN 30A	⑪ P/W 30A	⑳ T/LP 10A	⑳ —
② AD FAN 30A	⑫ IG KEY1 30A	㉑ ETC 7.5A	㉑ ENG BAR 10A
③ ABS 60A	⑬ MAIN 120A	㉒ ENG-B 10A	㉒ INJ 15A
④ DEFOG 40A	⑭ FOG 15A	㉓ STOP 15A	㉓ ILLUMI 10A
⑤ IG KEY2 40A	⑮ <H.CLEAN 20A>	㉔ HAZARD 10A	㉔ TAIL 10A
⑥ BTN 40A	⑯ <R.S/W 15A>	㉕ <TCM 15A>	㉕ SPARE 10A
⑦ BLOWER 40A	⑰ S/ROOF 15A	㉖ HEAD HR 10A	㉖ SPARE 15A
⑧ —	⑱ P/SEAT 30A	㉗ HEAD HL 10A	㉗ SPARE 20A
⑨ FUEL PUMP 20A	⑲ —	㉘ HEAD LL 15A	⑳ —
⑩ HORN 20A	⑳ MAG 10A	㉙ HEAD LR 15A	㉙ M DEF 7.5A

() The name is indicated in the box cover of the
 < > if equipped
 * Space

2. Basic illustration of power supply distribution

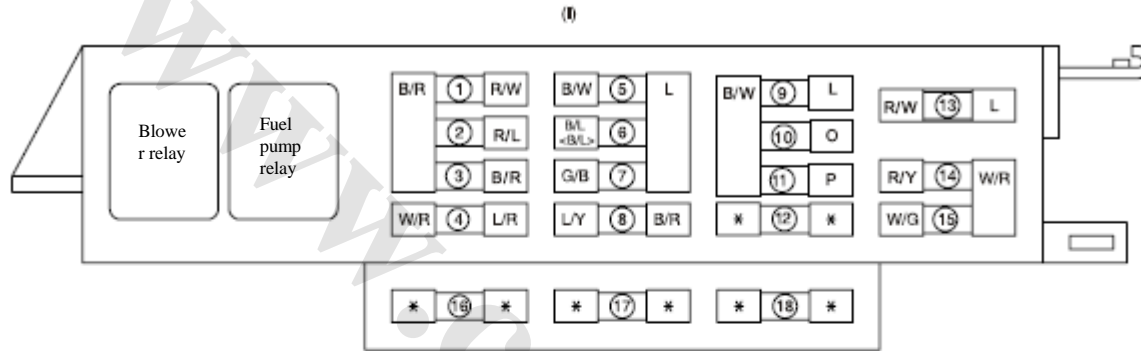

①	A/C 10A	⑩	MIRR 5A
②	S.WARM 15A	⑪	R. CIGAR 15A
③	R.WIP 10A	⑫	—
④	ROOM 15A	⑬	IG1P/W 30A
⑤	ENGINE 15A	⑭	P/W 20A
⑥	SAS 10A	⑮	D/L 30A
⑦	METER 15A	⑯	SPARE 20A
⑧	WIPER 20A	⑰	SPARE 15A
⑨	CIGAR 15A	⑱	SPARE 10A

* Space

2. Basic illustration of power supply distribution

2.2 Positions of harness and ground points of the entire car

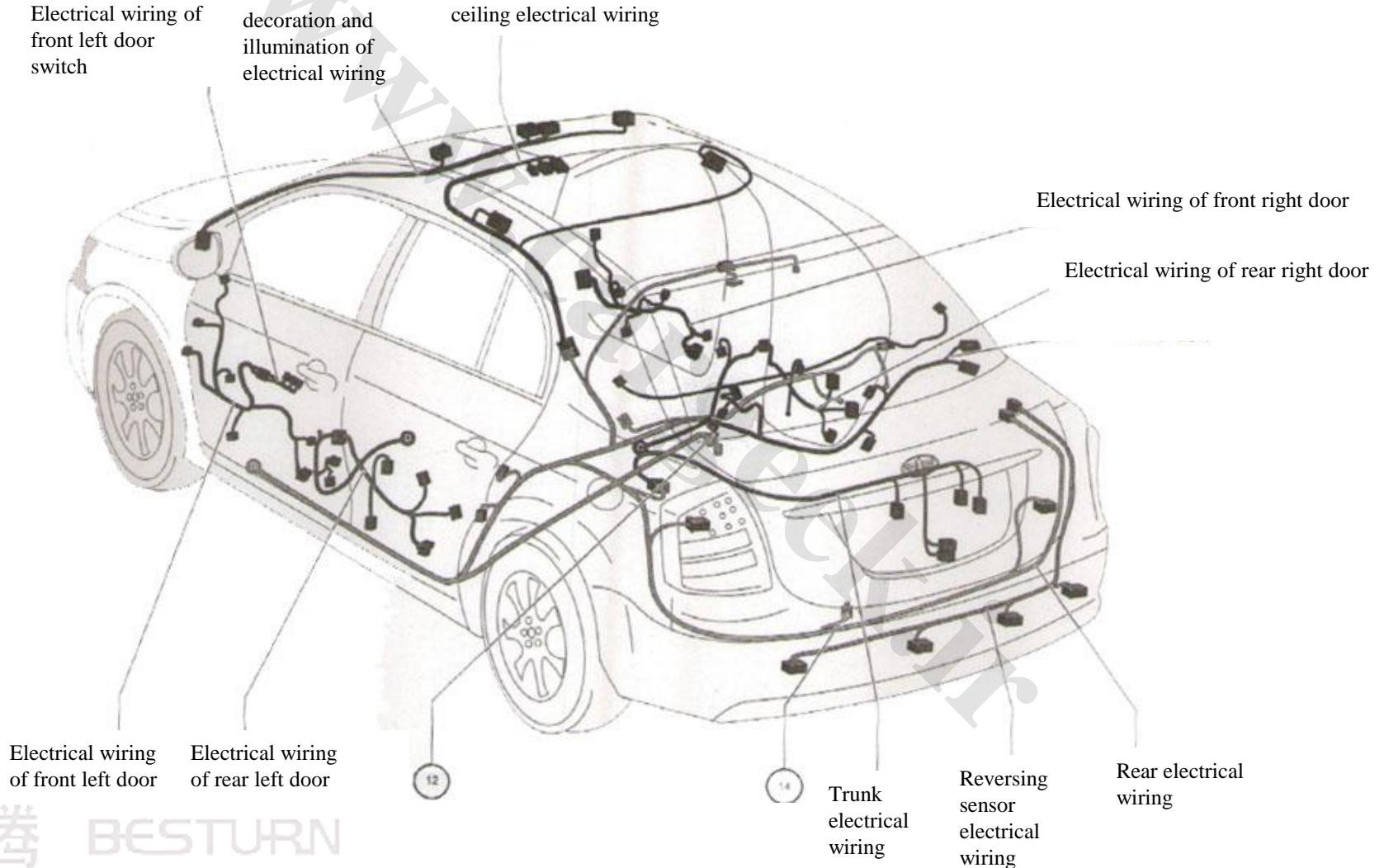

2. Basic illustration of power supply distribution

2.3 Current output diagram of the power supply

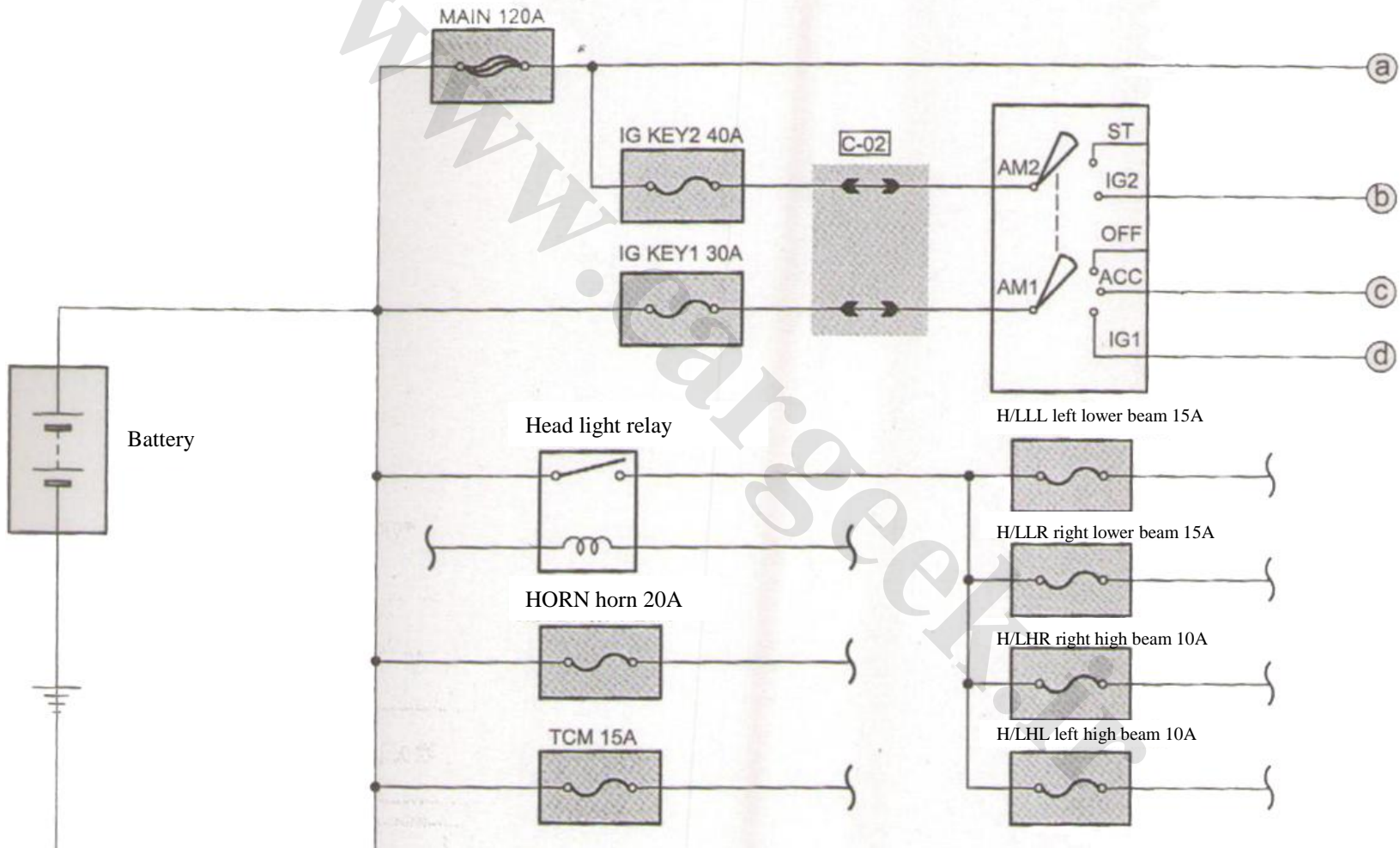

2. Basic illustration of power supply distribution

2.3 Current output diagram of the power supply

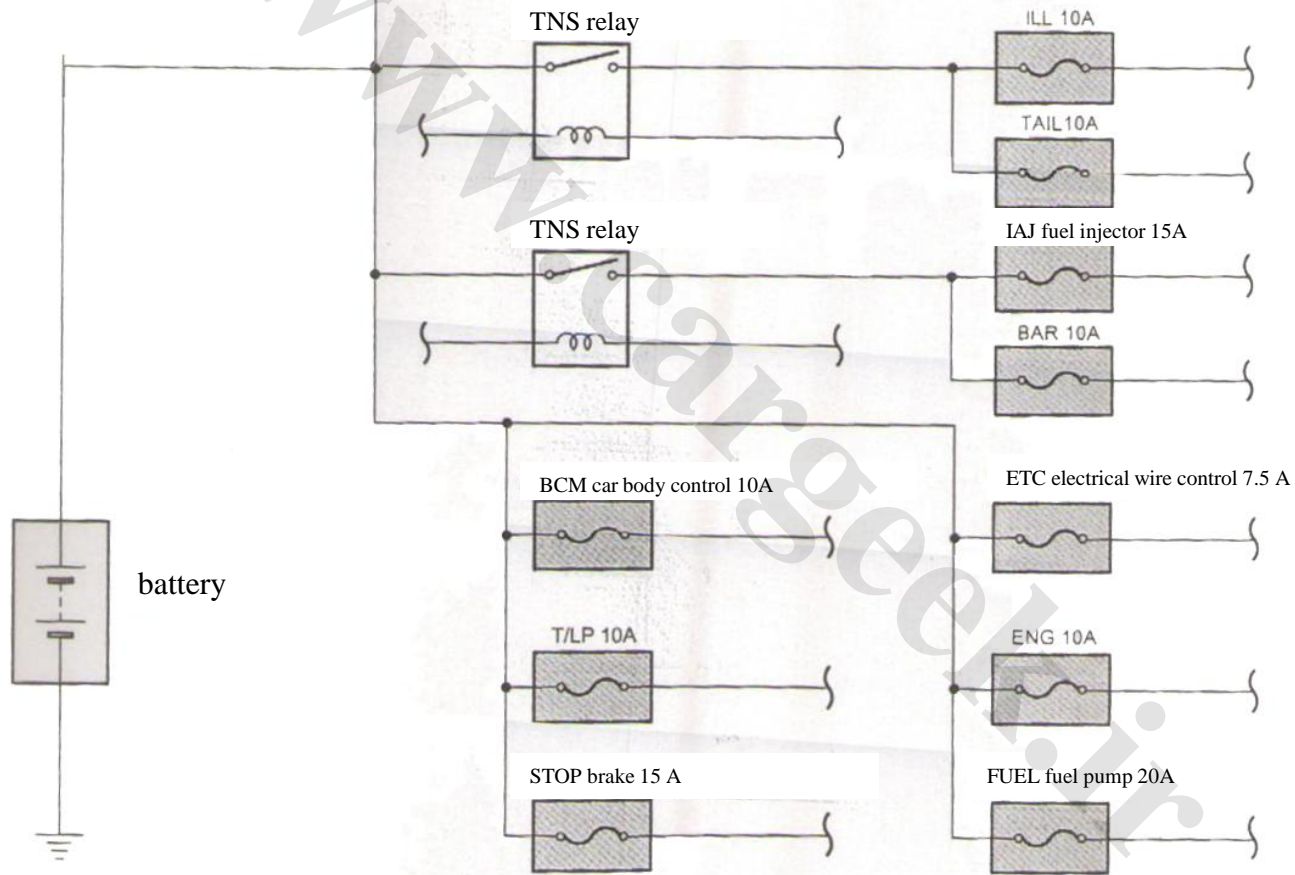

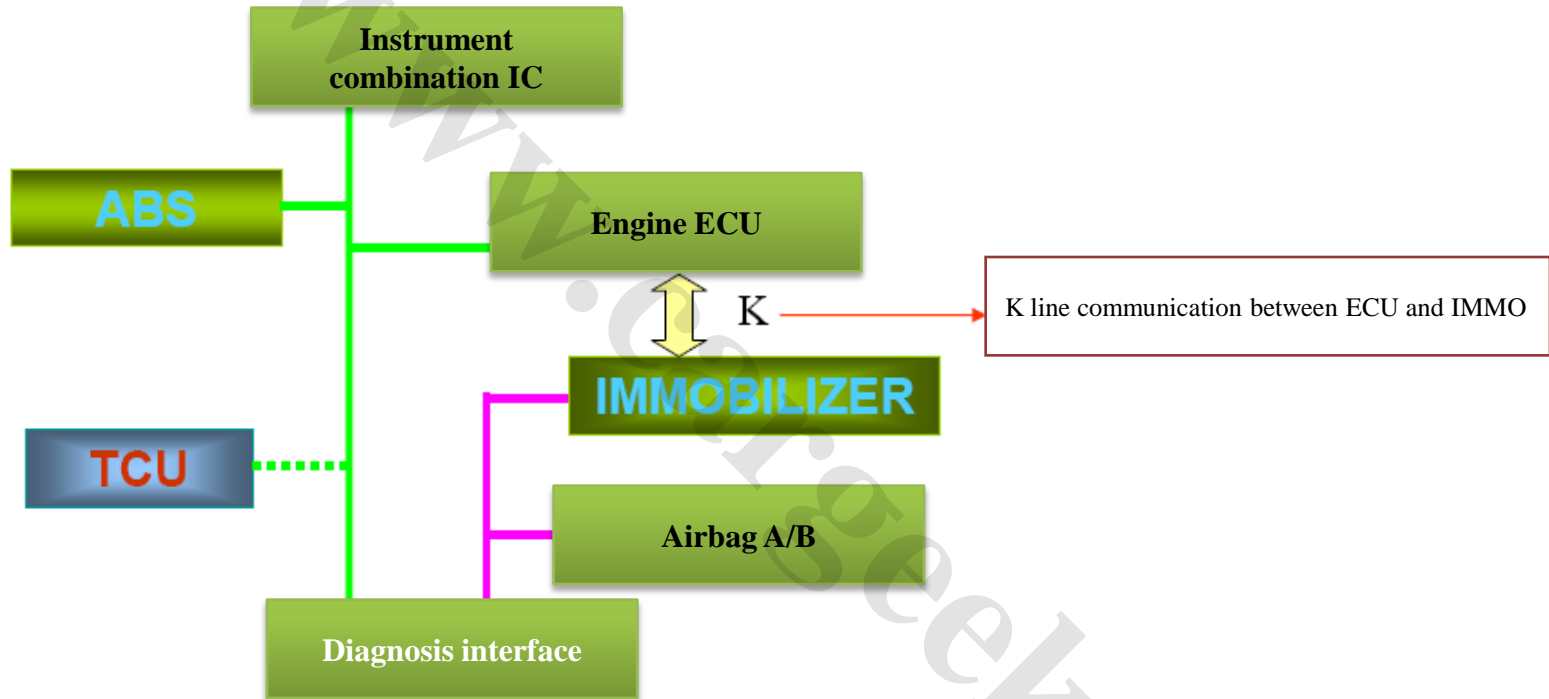

3.1 Network topology of Besturn 50



Definition of communication system :

MT type has three CAN communication nodes (reducing TCU)

AT type has four CAN communication nodes

-  CAN bus communication
-  K wire diagnosis

3.2 Terminal resistance

- Two 120-Ω resistors in the power CAN bus are located in PCM and GW, two 120-Ω resistors in the instrument diagnosis CAN bus are located in IC and GW and two 120-Ω resistors in the comfort/information CAN bus are located in BCM and GW.
- Attention:
 - While measuring the resistance, the ignition switch must be turned to OFF and it is necessary to disconnect the negative electrode of the battery.
 - Two 120-Ω terminal resistors of the comfort/information CAN are measured directly as ∞ and the resistors are inside the module.

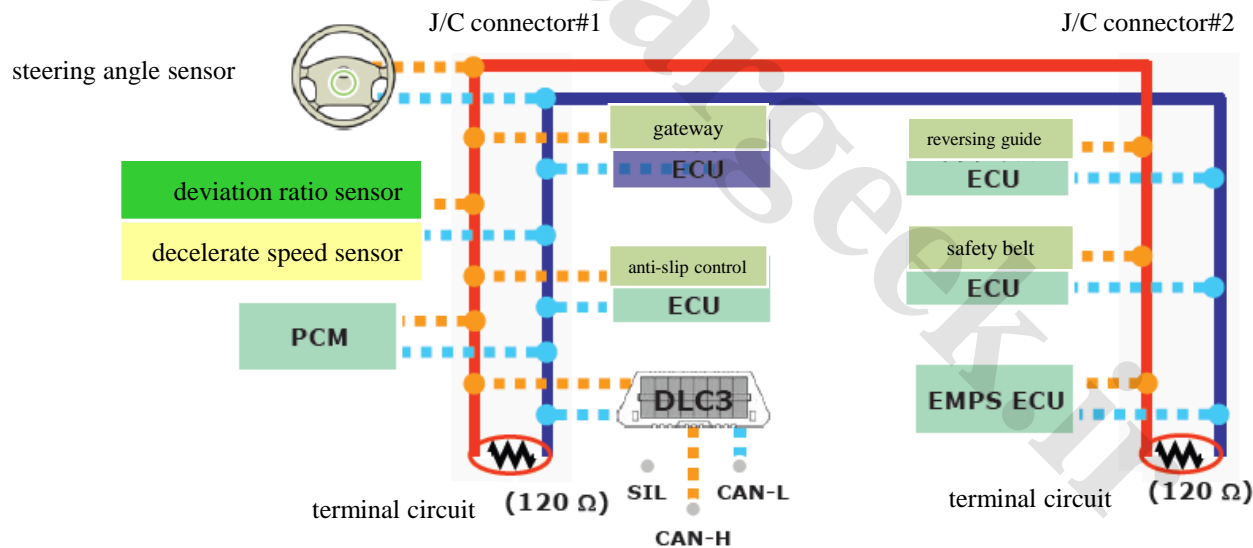

3.3 CAN bus technology

Advantages of the CAN bus:

- Reducing the number of sensors and signal leads.
- Reducing the number of leads in the harness.
- Reducing largely the weight of the lead harness.
- Making the number of plug core needles of the control device fewer.
- Improving the reliability and the durability.

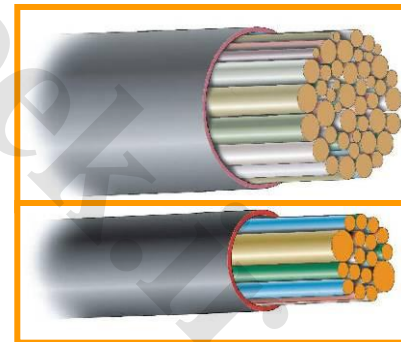

What is CAN bus?

Controller Area Network bus

- High-speed CAN bus, HSCAN transmission speed: 500KB/s
- Medium-speed CAN bus, HSCAN transmission speed: 95.24KB/s
- Low-speed CAN bus, HSCAN transmission speed: 33.3KB/s

High-speed bus HSCAN (for R750)	
Used for	Power system and chassis system
Transmission Speed	500KB/s
Wiring technology	Twisted pair cable
Time required to transmit one frame	Approx. 0.25 ms
Topology	Linearity
Bus cutoff resistor	120-Ω resistors at each end of the link
Largest number of the control devices	16(15+tester)
Maximum cable length	The accumulative length of 25 m within the car plus 5 m of the tester

3. Communication data bus

CAN Bus composition

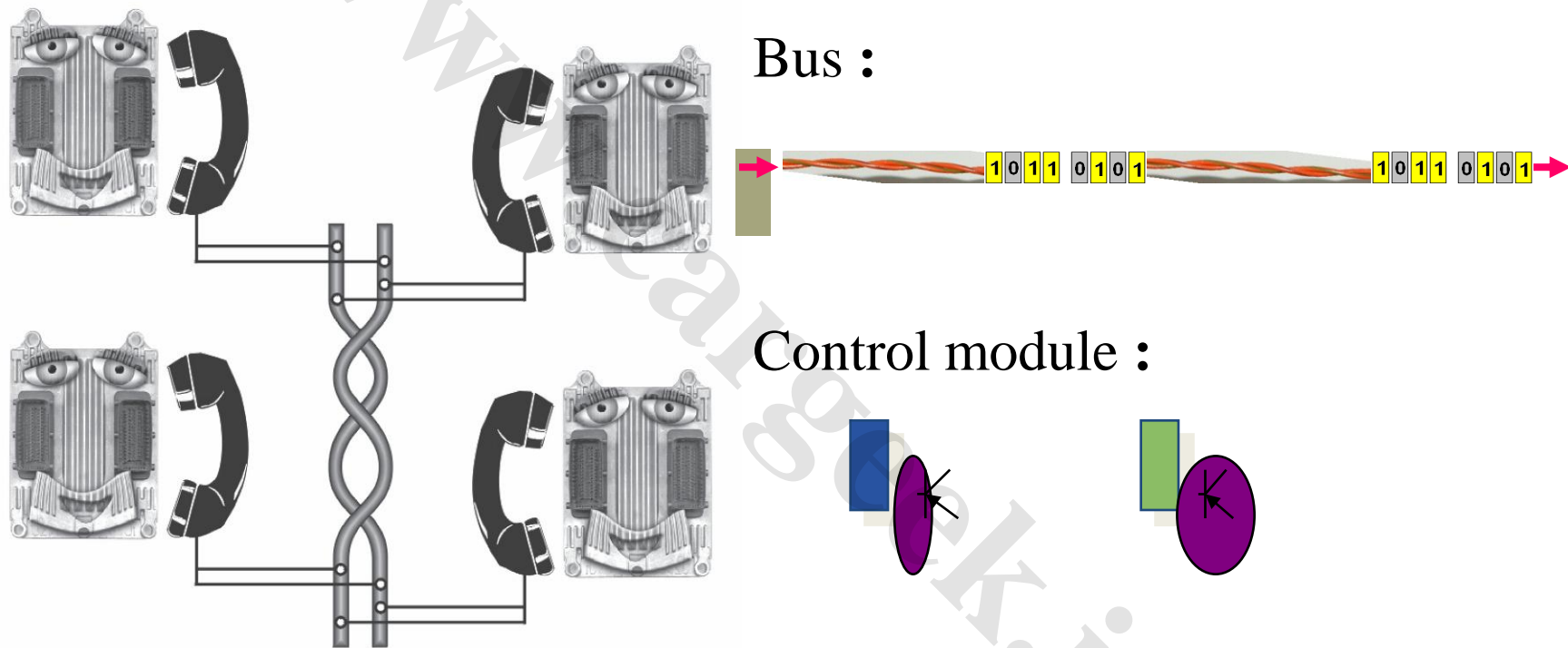

3. Communication data bus

CAN bus network structure diagram

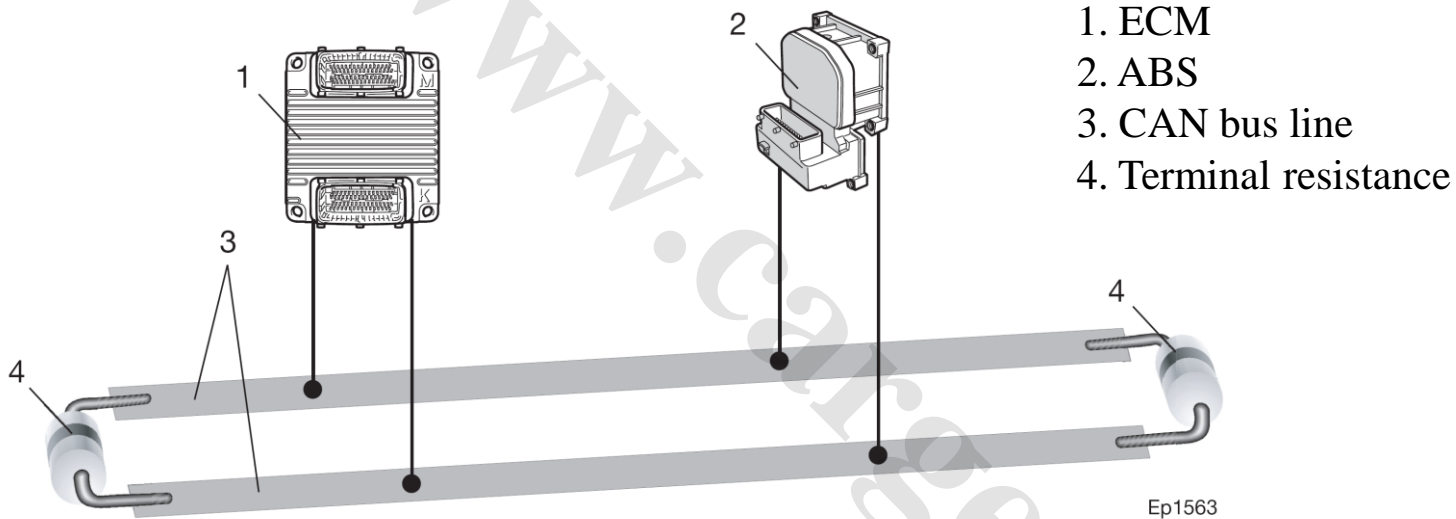

Module: receiving and sending data

Terminal resistor: to prevent the data from reversing back like the echo after reaching the line end and consequently interfering with original data.

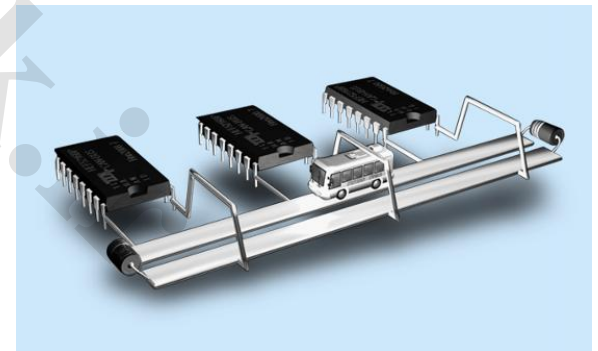

CAN Bus information structure

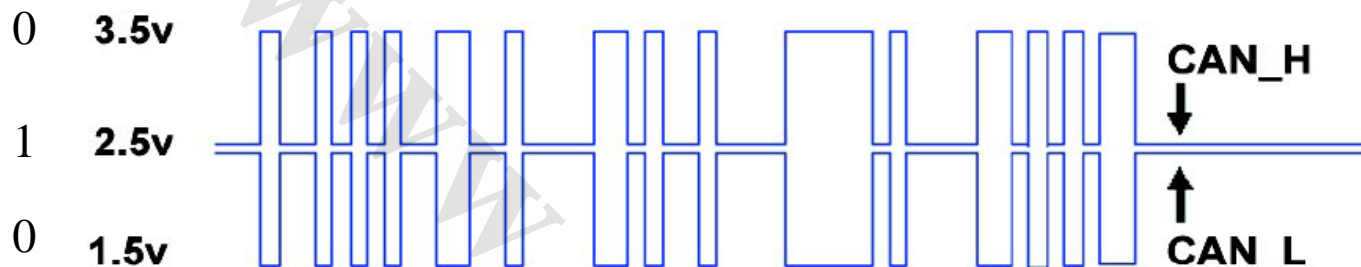

Commencement	Identifier/name	Control domain	Data 0-64Bits	Cyclic redundancy code check and test	Confirmation	End
--------------	-----------------	----------------	---------------	---------------------------------------	--------------	-----

All message length :Minimum 44Bits – maximum 108Bits.

- CAN bus information includes starting information and ending information.
- Identification signal: used to determine the information priority. When several pieces of information are sent out at a same time, it must be solved through arbitration.
- Control domain: number of bits of the sending signal carried, that is, length
- Cyclic redundancy code check and test: to perform the operation on the sending signal and make an error check by checking it with the cyclic redundancy code.
- Confirmation: to confirm the transmission code to find whether it is correct.

3.4 K line technology

K line

- K line is used for diagnosis communication between external testing devices and the car ECU
- The transmission speed is 20kb/s max.
- During the signal transmission, its voltage is changed between 0V and 12V: 12V, logic “1”; 0V, logic “0”

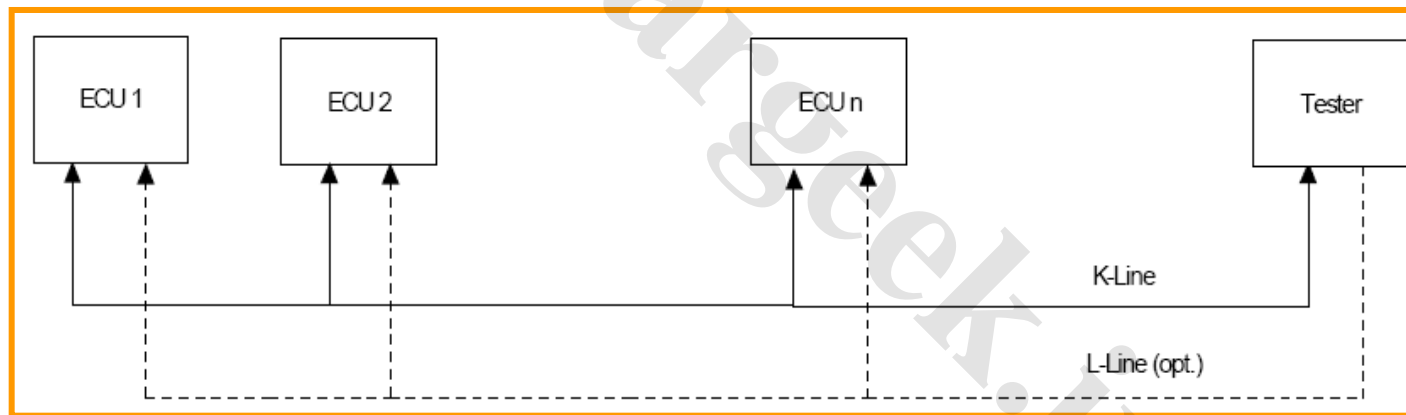

K line transmission data format

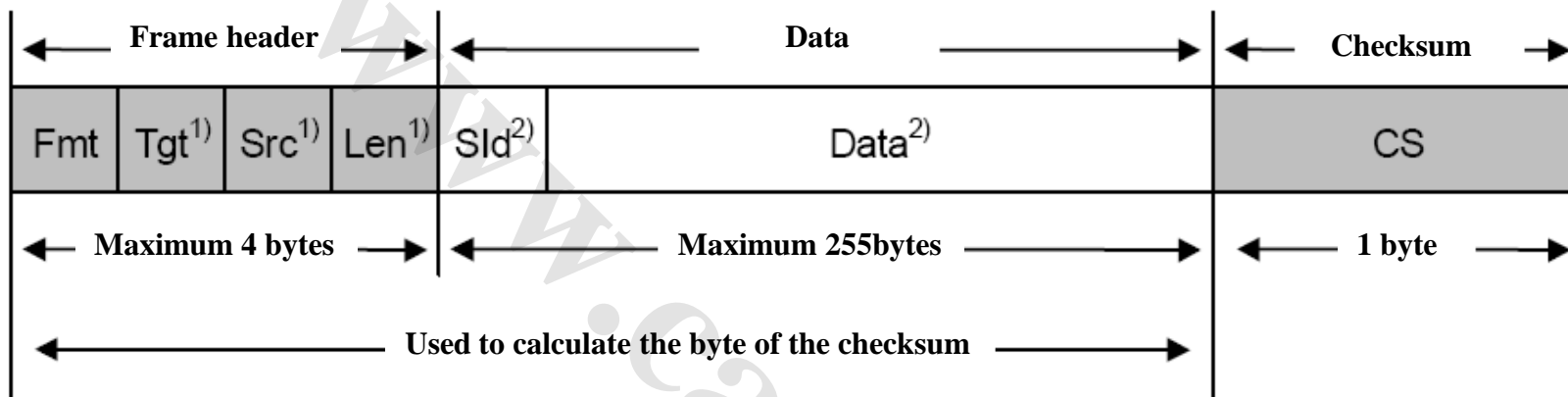

These bytes can either exist or not depending the value of Fmt byte.

Service identifier is part of the data.

Fmt format byte

SID service identifier byte

Tgt target address byte

Data data byte

Src source address byte

CS checksum byte

Len additional length byte

3.5 CAN fault waveform

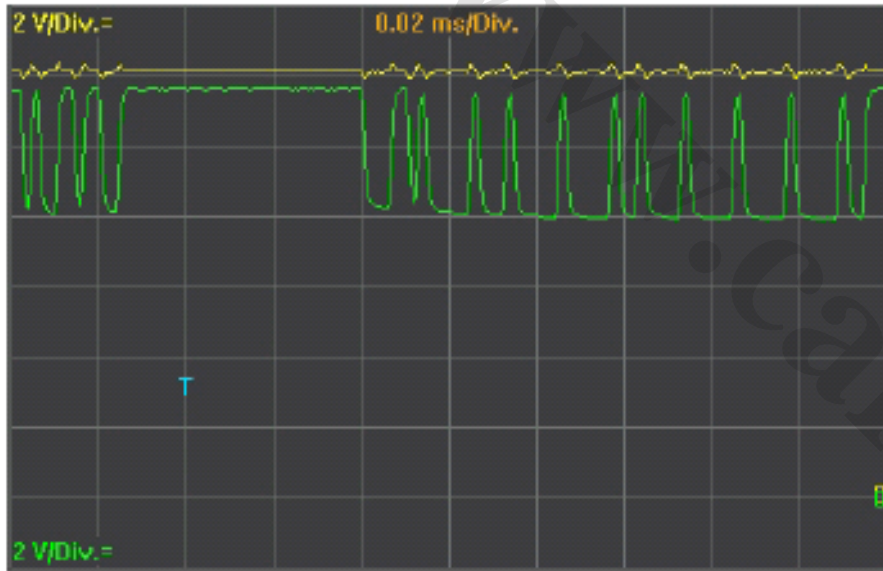

Description of fault:

CAN-high short circuit the positive electrode:
The voltage of CAN-high line is put at 12V.

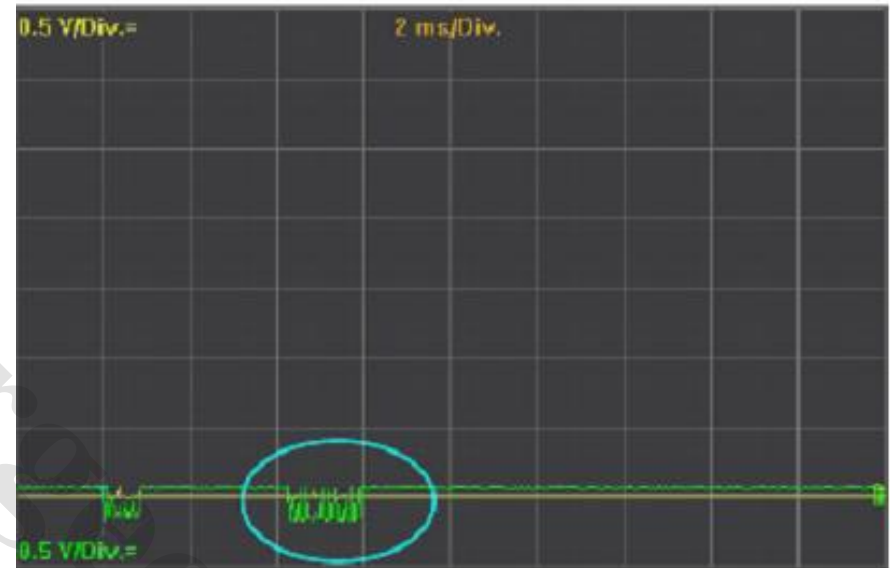

Description of fault:

CAN-high short circuit to the ground:
The voltage of CAN-high is 0 V and that of CAN-Low
is 0V too.

3.5 CAN fault waveform



Description of fault:
CAN-high open circuit

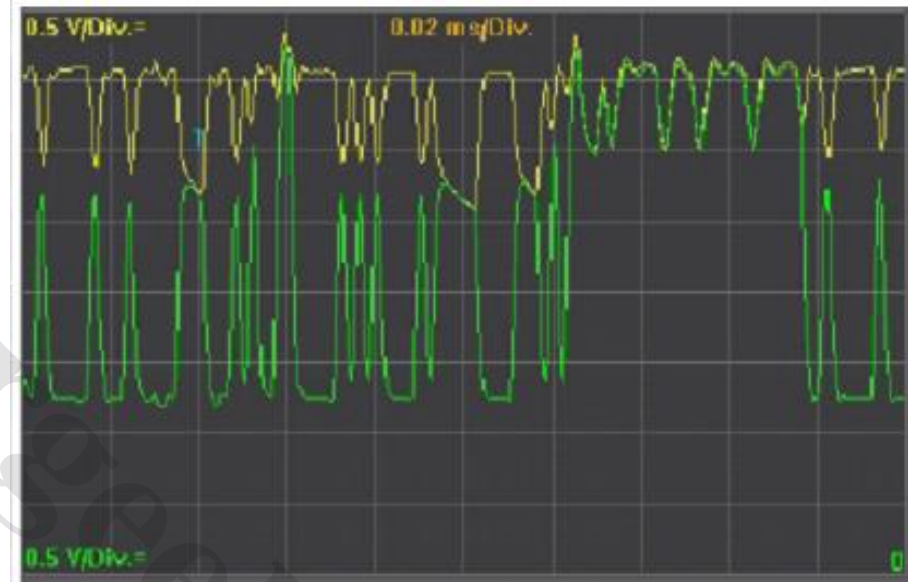

Description of fault:
CAN-Low open circuit

4. Car body control module BCM

4.1 BCM position overview

The car body module is located in the left internal decorative board under the instrument panel at the side of the drive in the cab.

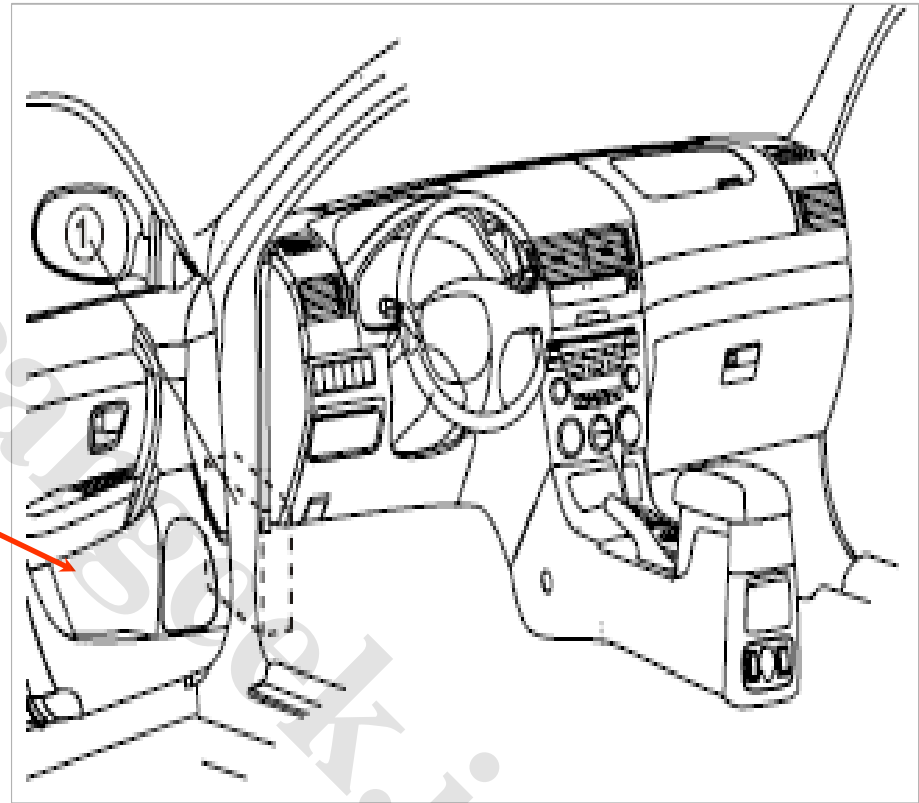

- The car body control module, called BCM for short, mainly is to receive some switch signals in the car as well as CAN and LIN bus signals, consequently achieving logical relationship control of corresponding loads.

4.2.1 Functions of B50 BCM

Instruction:

This system has five statuses: normal status, waiting to enter the security status, waiting to exit the security status, security no-alarm status and security alarming status.

1. Remote control/key/prompt function

Execution conditions: The key is not in the ignition lock.

Execution functions:

Press the unlocking key of the remote controller once or use the key to unlock once, the front left door is unlocked and the steering light flashes twice, which indicates that the system enters the normal status or waits to exit the security status;

Press the unlocking key of the remote controller twice or use the key to unlock twice (interval between two times shall be long than 500ms) within 3s, four doors and the luggage carrier are unlocked and the steering light flashes twice, which indicates that the system enters the normal status or waits to exit the body security status;

If all the switches of four doors and the luggage carrier are not closed while pressing the remote controller locking key to lock, the system will not take any action. Otherwise, locks of four doors and the luggage carrier are locked and the steering light flashes once, which indicates that the system enters the security no-alarming status;

Locks of four doors and the luggage carrier are locked while locking with the key. If all external detection devices are closed and the steering light flashes once, it indicates that the system enters the security no-alarming status; if all external detection devices are not closed and the steering light does not flash, the system enters the waiting to enter the security status. When all the devices are closed and the steering light flashes once, the system will enter the security no-alarming status again.

Notice: external detection devices include: four-door status switches, luggage carrier cover status switch, front left door and other door lock status switches.

2. Lock cylinder shielding function

Execution condition: the key is in the ignition switch

Execution function: signals of the front left door lock cylinder can not control the door lock and the luggage carrier lock and can not enter the security no-alarming status, consequently preventing abnormal automatic locking due to false triggering of lock cylinder signals.

4. Car body control module BCM

3. Remote control prohibition

It is prohibited to remote control when the key is in the ignition lock and within 4s after the key is pulled out from the ignition lock, consequently preventing error action due to false triggering of the buttons. After 4s, remote control can be used normally.

4. Secondary security

Execution condition: the key is not in the ignition lock, doors and the luggage carrier are closed, and the system is in the security no-alarming status or the waiting to exit the security status.

Execution function: after pressing the remote control unlocking key, the system will enter the waiting to exit the security status. If the doors or the luggage carrier are not opened or the key is not inserted in the ignition lock within 20s, the system will enter the security no-alarming status after 20s. Otherwise, it will enter the normal status.

5. Security alarming function

When the system is in the security no-alarming status, opening the door interlock switch, the door collision switch and the luggage carrier switch or inserting the key in the ignition lock by force can make the system enter the security alarming status. While alarming, left and right steering lights will flash (the frequency depending on the flashing relay) and the horn will sound (frequency of 2 ± 1 Hz). The alarm will stop after maintaining for 25-30s. If any other detection point is triggered, the system will repeat alarming.

Pressing any key of the remote controller once during alarming will stop the alarm. However, the system still is in the security no-alarming status.

Press the unlocking key of the remote controller for the second time, the system will enter the waiting to exit the security status.

Press the unlocking key of the remote controller for the second time, the system will enter the security no-alarming status.

Unlocking with the key (front left door or luggage carrier lock cylinder switch) or turning the key in the ignition lock to ACC shift during alarming will stop the alarm and the system will enter the normal status.

Locking with the key (front left door or luggage carrier lock cylinder switch) during alarming will stop the alarm and the system will enter the security no-alarming status.

In the security alarming status, if power supply of the battery is disconnected, it will re-alarm for 25-30s after the power supply is recovered.

4. Car body control module BCM

6. Central control function

If the driving speed of the car does not exceed 20km/h, when the front left door interlock is triggered to unlock (lock), other door locks will be unlocked (locked) simultaneously.

If the driving speed of the car exceeds 20km/h, the central control function of the front left door interlock switch is prohibited.

7. Functions of the luggage carrier key lock:

When the luggage carrier lock cylinder is opened with the key, the system will enter the normal status with the steering lights flashing twice as the hint.

When the luggage carrier lock cylinder is closed with the key, the system will automatically enter the status that it is in before opened:

If it is in the security no-alarming status before the luggage carrier is opened and the car doors are not opened or the key is not inserted in the ignition lock during this period, after the carrier is closed, the system will enter the security no-alarming status again with the steering lights flashing once as the hint. If it is in the normal status before opened, it will still be in the normal status after the carrier is closed. If it is in the security alarming status before opened, after the carrier is closed, it will be in the security no-alarming status with the steering lights flashing once as the hint.

8. Lightening function of internal lights

Execution condition: the internal light switch is put in the DOOR shift

Execution functions:

In the case that all the doors are closed, the internal lights will be lightened and go out after 10 minutes when any door is open and they will be lightened and go out after 10s (when the key is not in the ignition lock) or after 1s (when the key is in the ignition lock) when the door is closed.

In the case that all the doors are closed, the internal lights will be lightened and go out after 10s when the key is pulled out from the ignition lock. The internal lights will go out after 1s when the key is inserted in the ignition lock during the period they are on.

While unlocking with the remote controller or the key, the internal lights will be lightened and go out after 10s. Locking with the remote controller or the key during the period the internal lights are on will make them go out.

4. Car body control module BCM

www.CarGeek.ir



9. Passport learning (only one remote controller can be learned for one car)

Execution condition: the car doors are opened, the key is in the ignition lock and the system is in the normal status.

10. Automatic locking function

Execution condition: the key is in the ON shift within the ignition lock and the front left door is in the unlocking status.

Execution functions:

When the car speed exceeds 20km/h (when the number of high and low levels with the width less than 37ms in the speed signals except first two levels reaches 10), this controller will output the locking signal of which the time is 450 ± 50 ms.

For artificial unlocking, when the car speed exceeds 20km/h again after it is lower than 20km/h (when the number of high and low levels with the width between 37ms and 200ms in the speed signals except first two levels reaches 2), this controller will output the locking signal again.

11. Automatic unlocking function

Execution conditions: the key is in the ignition lock and the front left door is in the locking status.

Execution function: when the key is pulled out from the ignition lock, this controller will output the unlocking signals. When this controller receives signals, which are low levels more than 170ms, from the airbag controller if collision occurs whether the front left door is unlocked or locked, this controller will output the unlocking signals.

12. Collision memory function:

Execution condition: the airbag detonates.

Execution function: After the detonation, the controller will receive low level signal input more than 170ms from the airbag. If the controller does not output the unlocking signals, the collision signal detection pin will cyclically output signals of high level of 65ms and low level of 220ms. If the controller outputs the unlocking signals, the collision signal detection pin will cyclically output signals of high level of 220ms and low level of 220ms.

Notice: If a collision re-occurs after the first collision, the latest status will be maintained.

4. Car body control module BCM

13. "Optional" automatic locking function

Execution condition: the key is in the ignition lock, the speed is zero, the doors and the luggage carrier are closed and the system is in the normal status.

Execution functions:

The following actions shall be done within 8s: turn on and off the status switch of any door for five times (the interval between operations shall be longer than 150ms) and then pull the key out of the ignition lock.

The steering light will flash three times after the key is pulled out of the ignition lock, which indicates that the system enters the function switching status.

If the original system has the automatic locking function, this function will disappear. If the original system has cancelled the automatic locking function, this function will be re-activated.

14. Lighting power saving function and headlight delay lighting function

Execution functions:

In any of the following conditions, the lighting power saving relay is disconnected and the internal lights (Normal open shift) and front combination lights will be shut down by force.

After 20s the system is put into the security system with the remote controller (this time is the headlight delay time);

After 20s the car is locked via the front left door lock cylinder with the mechanical key (this time is the headlight delay time).

In any of the following conditions, the lighting power saving relay is connected and the internal lights (Normal open shift) and front combination lights can return normal.

The front left door lock cylinder or the luggage carrier lock cylinder is opened or closed with the key or unlocked or locked with the remote controller;

The key tip switch status changes or the ignition switch shift changes.

4. Car body control module BCM

4.2.2 B50 BCM schematic diagram

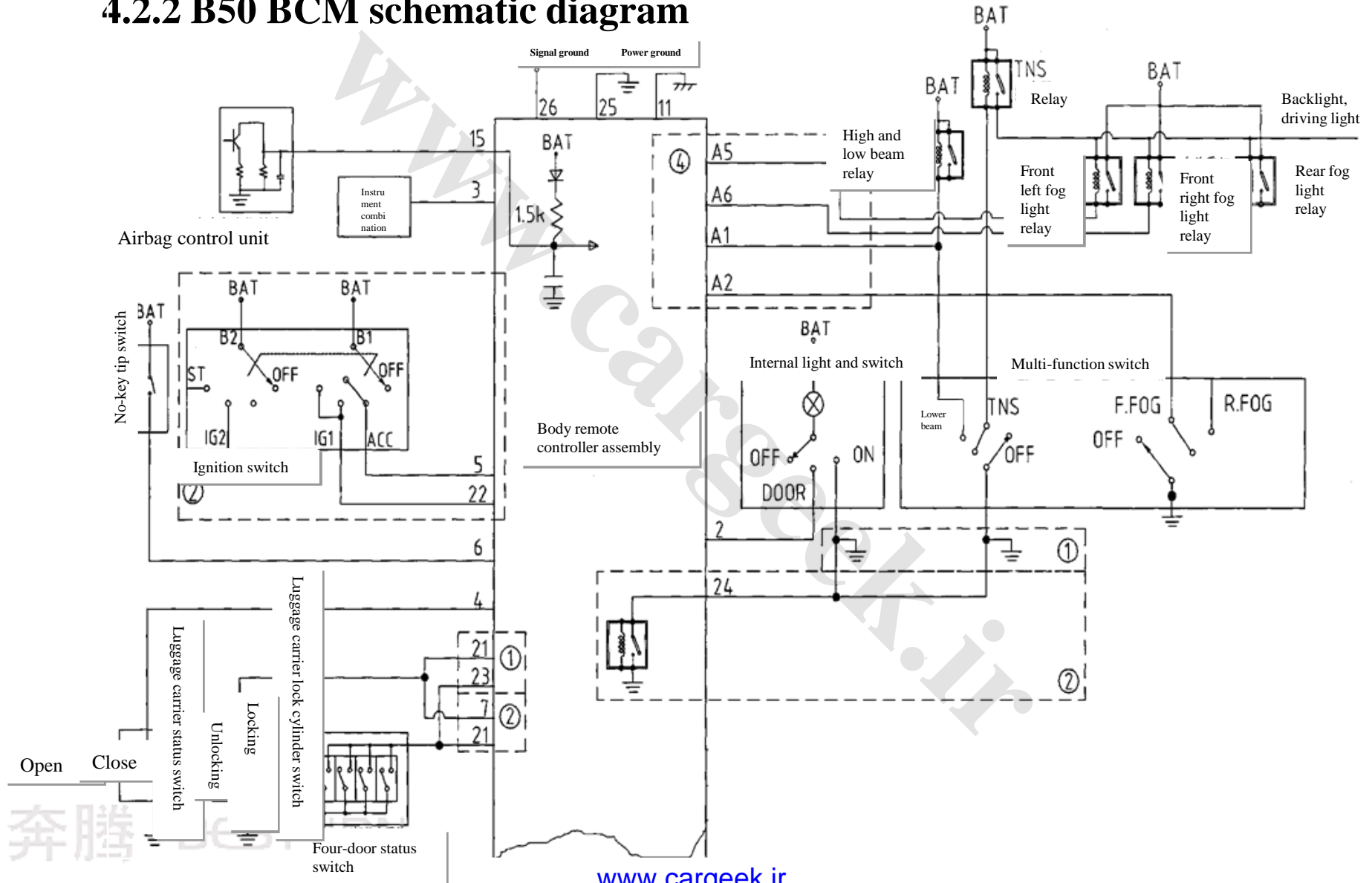

4. Car body control module BCM

Continued

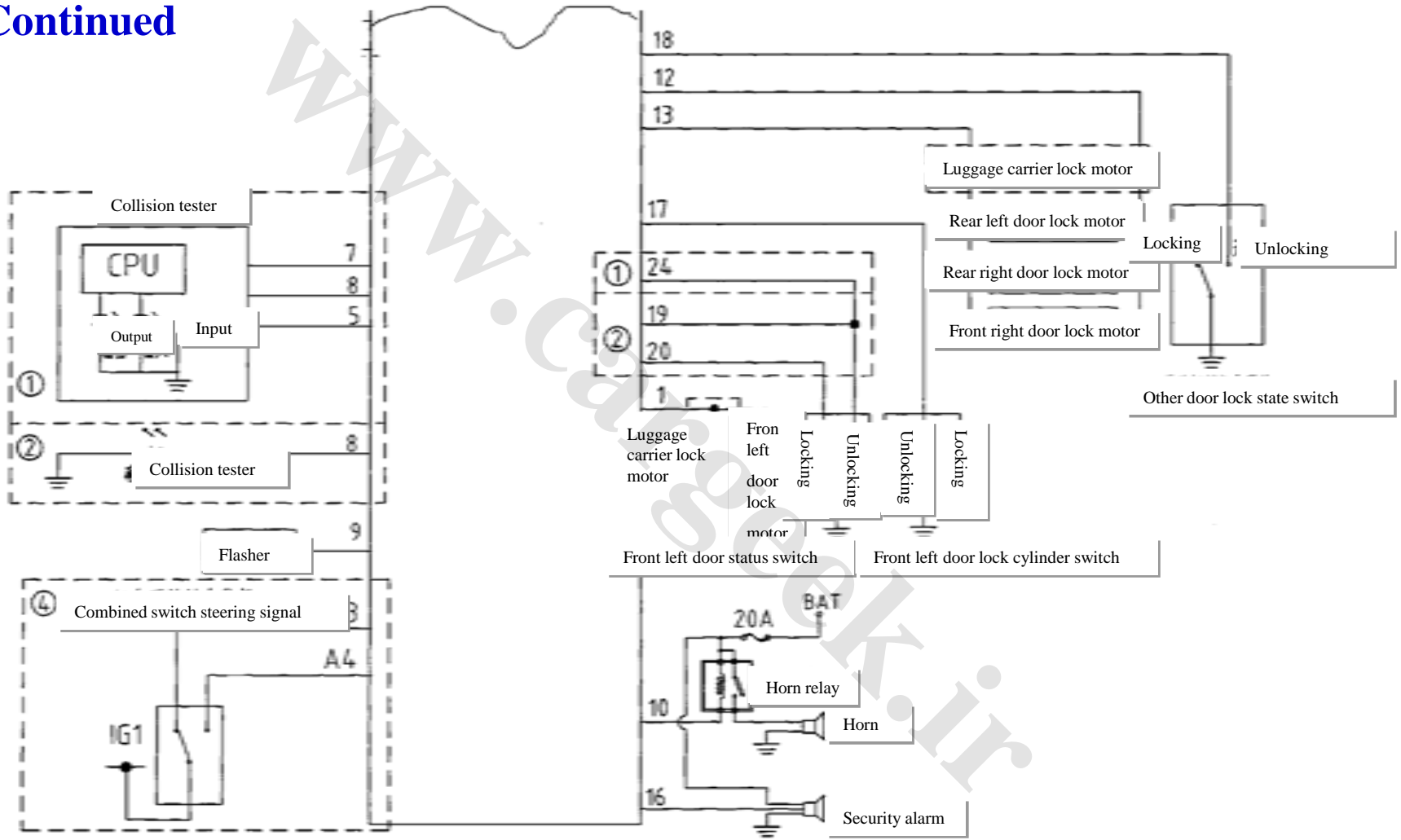

Electric schematic diagram of the car body remote controller assembly

4.2.3 Pin illustration of B50 BCM

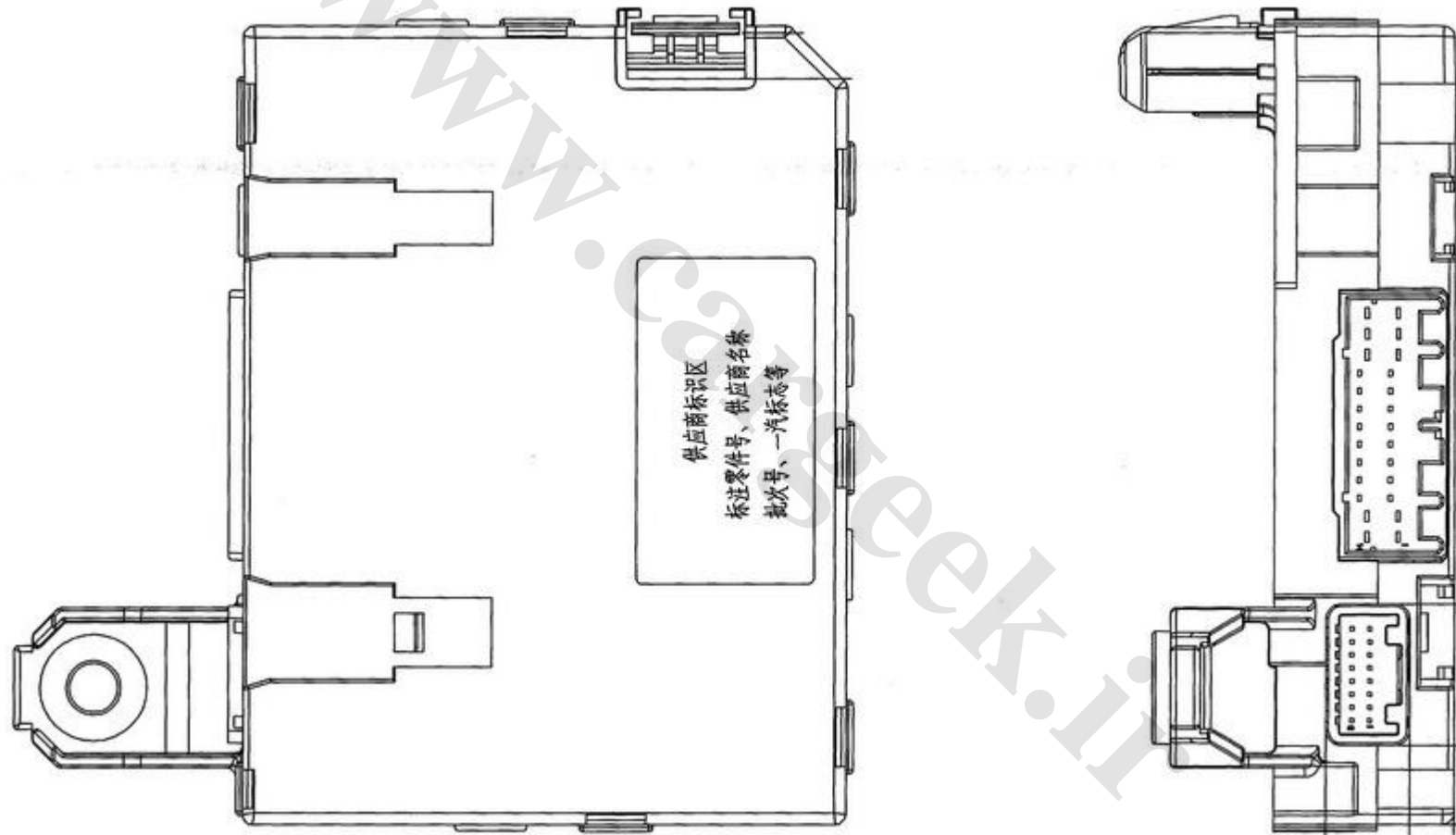

4. Pin illustration of B50 BCM

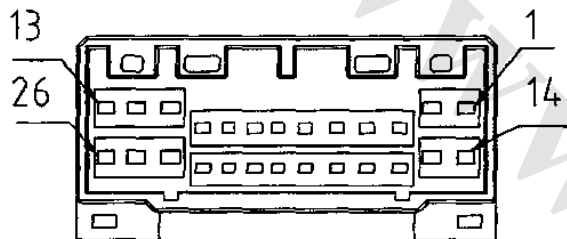

Pin definition illustration	Pin definition illustration
1 Front left door lock unlocking output	14 Front left door lock unlocking output
2 Internal light signal output	15 Airbag detonation signal
3 Speed signal input	16 Security alarm
4 Luggage carrier cover status switch	17 Front left door lock cylinder switch
5 ① System resetting ② Ignition switch ACC gear	18 Other door lock status switch
6 Keyless tip switch	19 ① space ② Front left door lock status switch unlocking terminal
7 ① Collision signal output detection ② Luggage carrier lock cylinder switch	20 ① space ② Front left door lock status switch locking terminal
8 Collision signal detection	21 ① Luggage carrier lock cylinder switch ② Four-door status switch
9 Danger warning signal output	22 ① space ② Ignition switch IG1 gear
10 Horn relay	23 ① Door collision switch ② not used
11 Power ground	24 ① Front left door lock status switch ② Lighting power saving relay control terminal
12 Other door lock unlocking output	25 Signal ground
13 Other door lock locking output	26 BAT

4.3.2 Pin illustration of B50 BCM

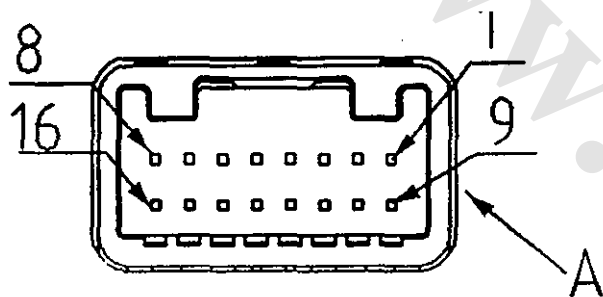

Pin definition illustration
A1 combined switch low beam light signal - input
A2 combined switch front fog light signal - input
A3 combined switch left steering signal - input
A3 combined switch right steering signal - input
A5 left fog light relay control signal – output
A5 right fog light relay control signal – output
A7 space – A16 space

www.cargeek.ir
Thank you !

奔腾 BESTURN

Technical Training of BESTURN B50

air conditioner control system

奔腾 BESTURN

Suitable post: Technical chief

Internal data, please do not disclose it externally

Curriculum Goals

- To master design features and working principles of the air conditioner refrigerating system
- To master the maintenance and diagnosis methods of the air conditioner refrigerating system
- To master working principles of the manual air conditioner control system
- To master the maintenance and diagnosis methods of the manual air conditioner refrigerating system
- To master working principles of the automatic air conditioner control system

Contents



1. Refrigerating and heating loop system of the air conditioner

2. Regulation and distribution of air conditioner

3. Overview of the automatic air conditioner

4. Input components of the automatic air conditioner

5. Output functions of the air conditioner control system

1. Refrigerating and heating loop system of the air conditioner

www.CarGeek.ir



1.1 Composition of the air conditioner refrigerating system

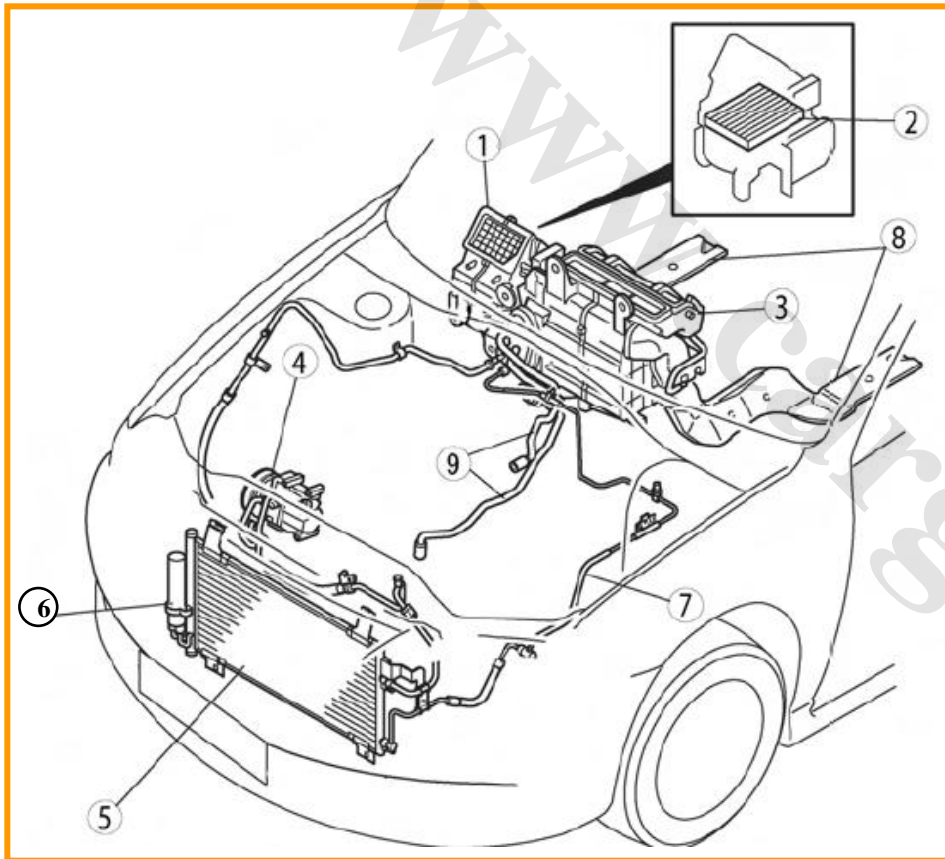

- 1 Blower device
- 2 Air filter
- 3 Air conditioning unit
- 4 A/C compressor
- 5 Condenser
- 6 Receiver/dryer
- 7 Refrigerant line
- 8 Air passage for the rear heater
- 9 Heater hose

1. Refrigerating and heating loop system of the air conditioner

www.CarGeek.ir



1.2 Form of the refrigerating system

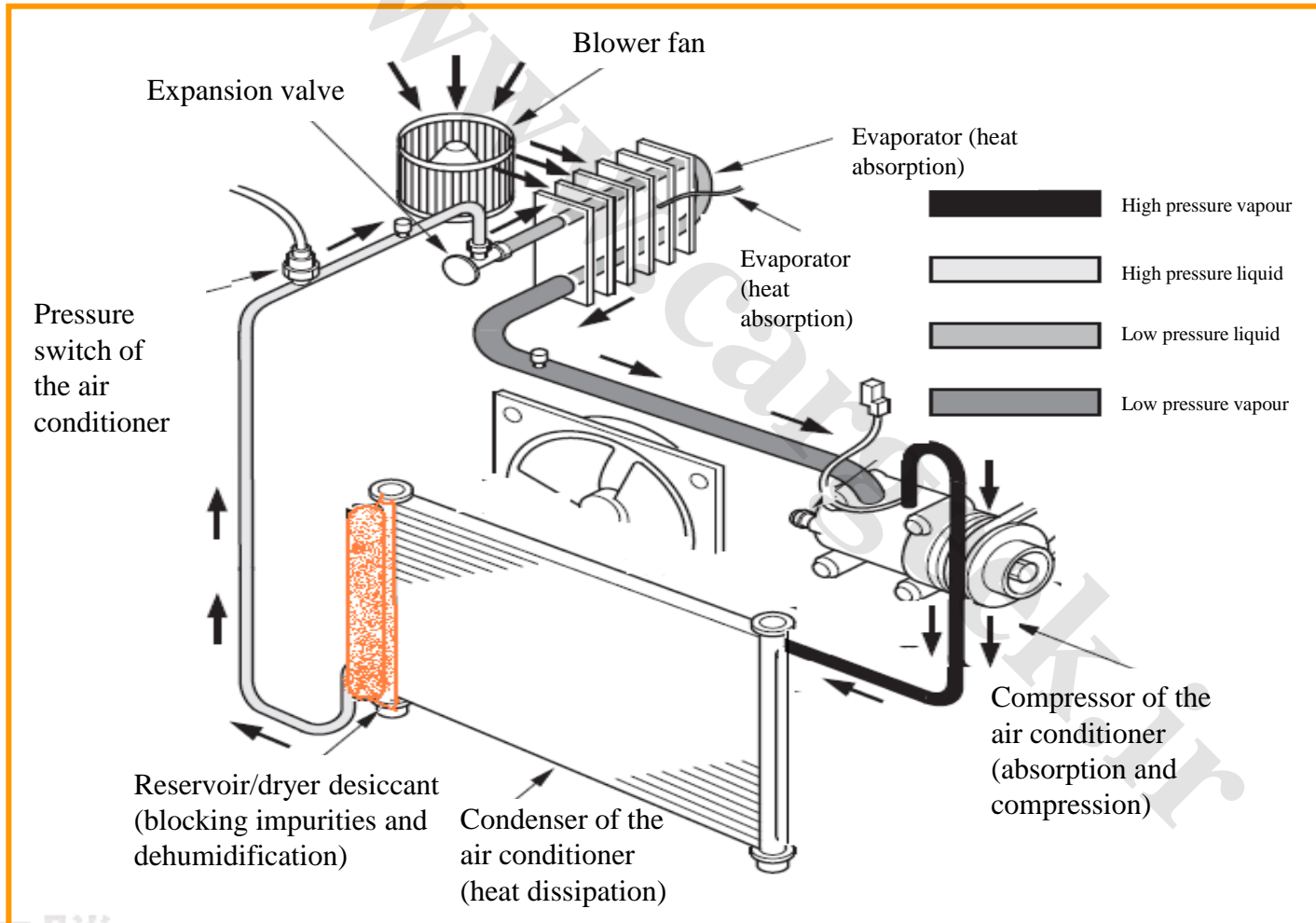

Components and elements of the refrigerating system:

Compressor, throttle tube, evaporator, collection dryer, condenser etc.

1. Refrigerating and heating loop system of the air conditioner

www.CarGeek.ir



1.3 Location plan of components of the refrigerating system

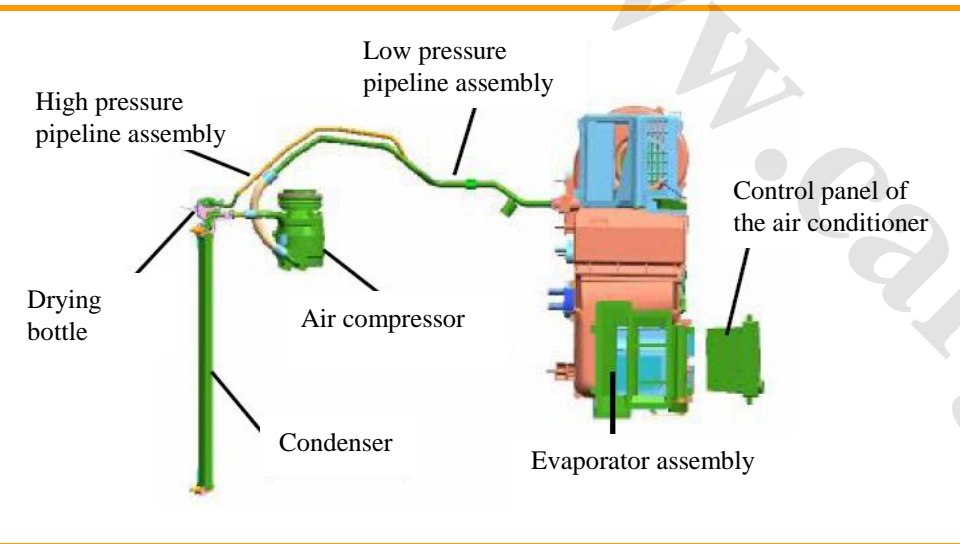

A3 The refrigerating system of the air conditioner adopts the method of vapour compression for refrigeration and R-134a as the refrigerant. Its basic working principle as follows:

- After compressed by the compressor, the refrigerant is changed into high temperature high pressure vapour and then enters into the condenser.
- In the condenser, the refrigerant vapour is cooled into high pressure medium temperature liquid.
- After filtration and drying by the receiver dryer, through throttling and pressure reduction of the expansion valve, low pressure low temperature refrigerant liquid after pressure reduction flows into the evaporator. The liquid absorbs heat and evaporates in the evaporator and is changed into low pressure low temperature refrigerant gas. Then it enters into the compressor and repeats another circulation.

1. Refrigerating and heating loop system of the air conditioner

1.4 Refrigerant and lubricating oil

Filling specification of refrigerant and lubricating oil

Application	Spec.	Element number
PAG synthetic refrigeration lubricating oil	150 ml	
R134a filling capacity of the air conditioning system	625 ± 10g	

Lubricating oil addition when components of the refrigerating system are replaced

Lubricating oil addition of the replaced component	Lubricating oil addition: ml
Note: If refrigerant oil is removed from the air conditioning system during the recycling or the component replacement, it must be refilled according to the instructions.	
Air compressor	The oil volume of the compressor shall be refilled according to the volume that is actually poured out.
Condenser assembly	30 ml
Vaporizer	30 ml
Drying reservoir	20 ml

1. Refrigerating and heating loop system of the air conditioner

www.CarGeek.ir



1.5 Structure of the heating system

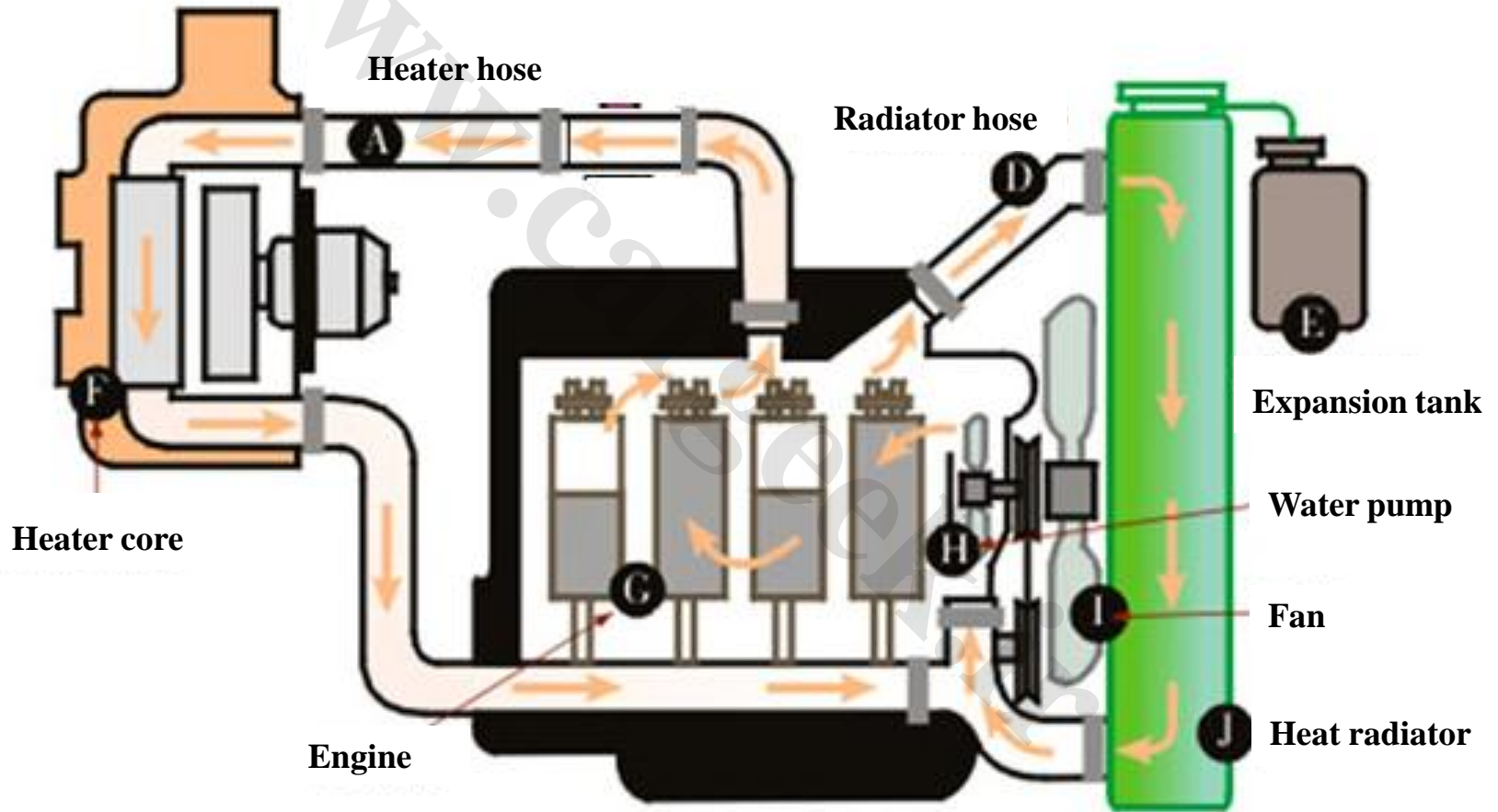

2.1 Location plan of air outlets in B50

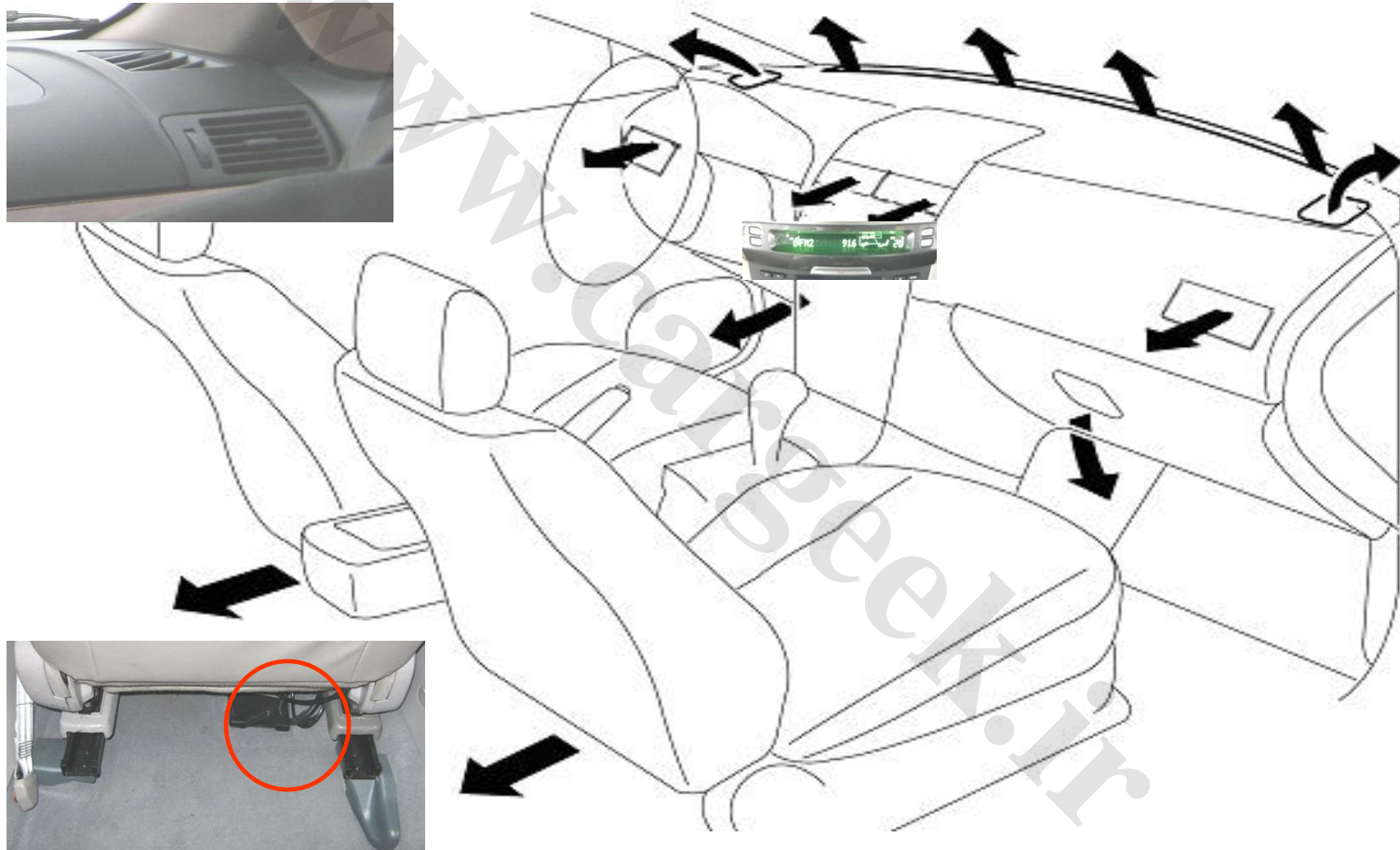

2.2 Air distribution structure

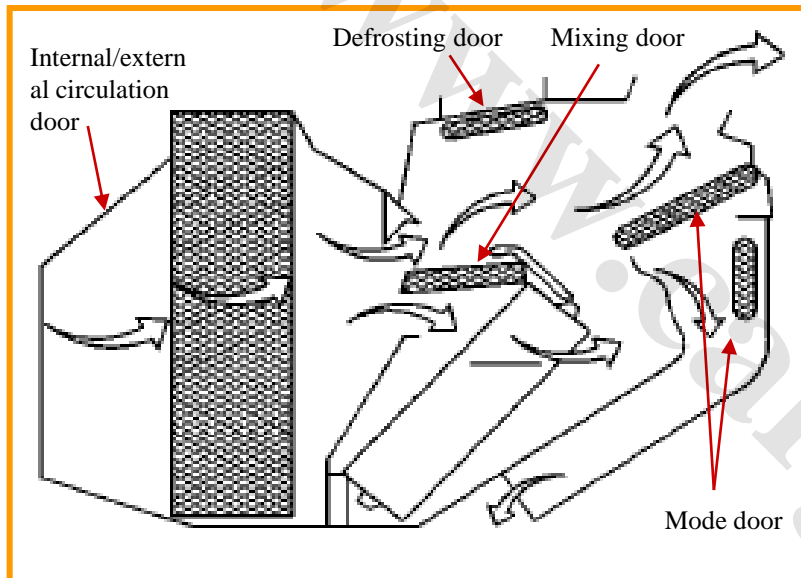

Internal sketch of the air distribution system

The control panel achieves various air distribution modes of the air conditioner by controlling the door motor whose drive is located in various doors along the bellows passage.

The air conditioning system has three door motors:

- Internal and external circulation door motor
- Mixed door motor
- Mode door motor

2. Regulation and distribution of air

www.CarGeek.ir

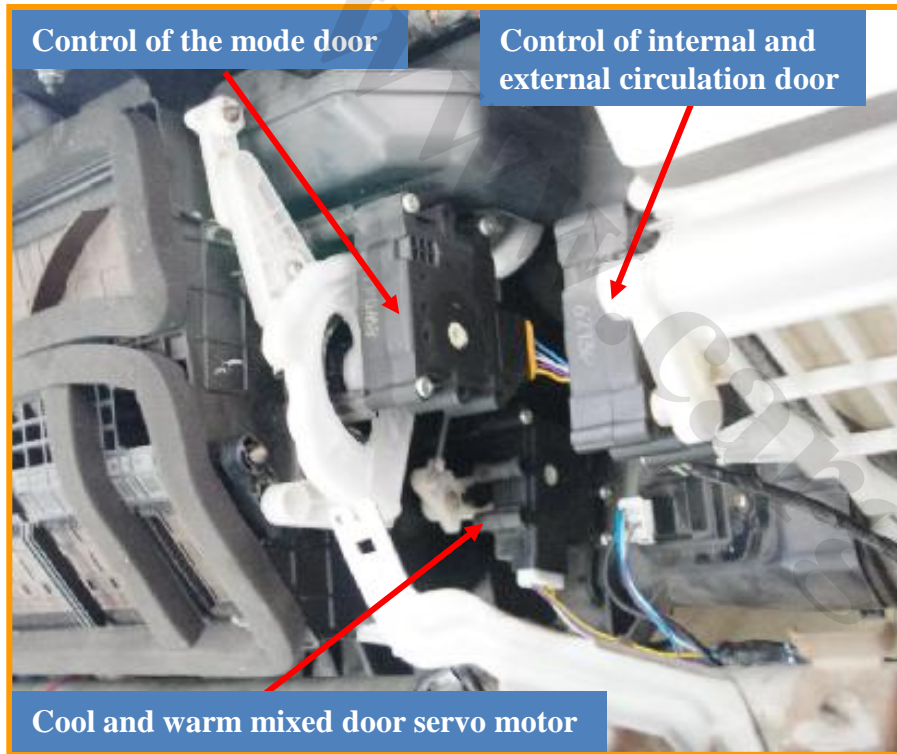

- The control panel achieves control of internal and external circulation air by controlling the internal and external circulation servo motor to drive the connecting rod and the deflector rod of the circulation door and consequently drive big and small circulation doors to rotate.
- The control panel achieves air mixing of different proportions by controlling the mixing door servo motor to drive the deflector plate and rod in the temperature regulating mechanism and consequently drive the mixing door to move.
- The control panel achieves control of the air flow direction by controlling the mode door servo motor and the defrosting door servo motor to drive the deflector plate and rod in the regulating mechanism. Opening and closing of different doors are controlled via different deflector rods.

2.3 Air distribution

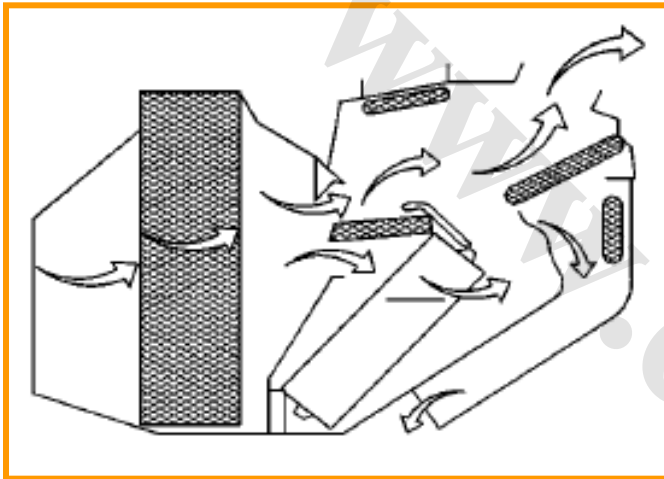

Blowing the face

- Mode door work
- Most air passes through the outlet of the instrument panel (blowing the face)
- A little of air flows through the passage blowing the foot

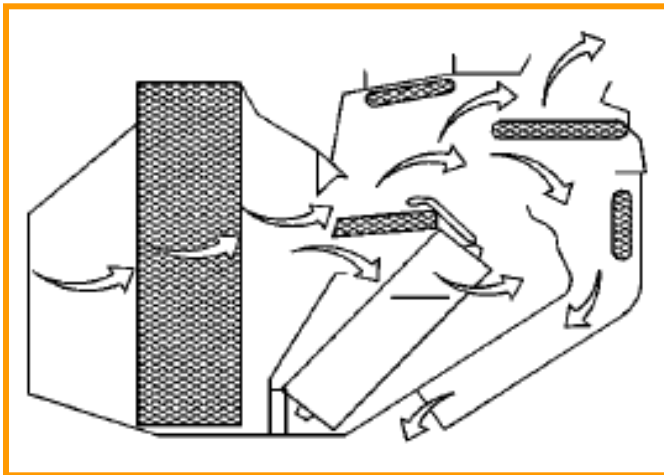

Blowing the face, blowing the foot

At this time, equivalent air passes through the following outlets

- Mode door work
- Outlet in the instrument panel (blowing the face)
- Floor outlet (blowing the foot)

2. Regulation and distribution of air

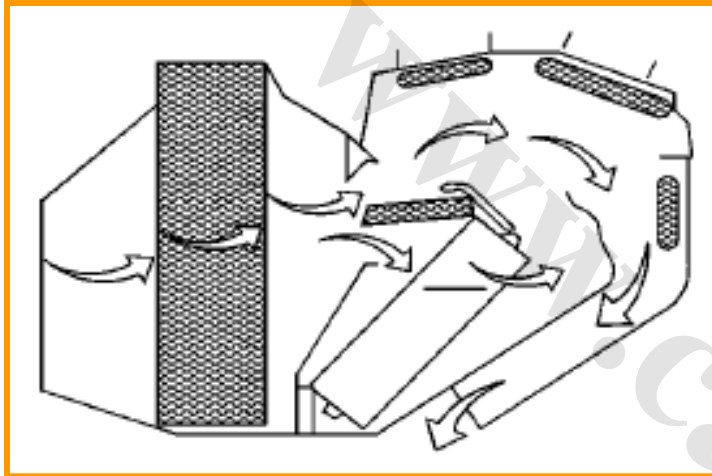

Blowing the foot

- Mode door work
- Most air passes through floor outlet (blowing the foot)
- A Little of air flows through the defrosting outlet (blowing the foot)

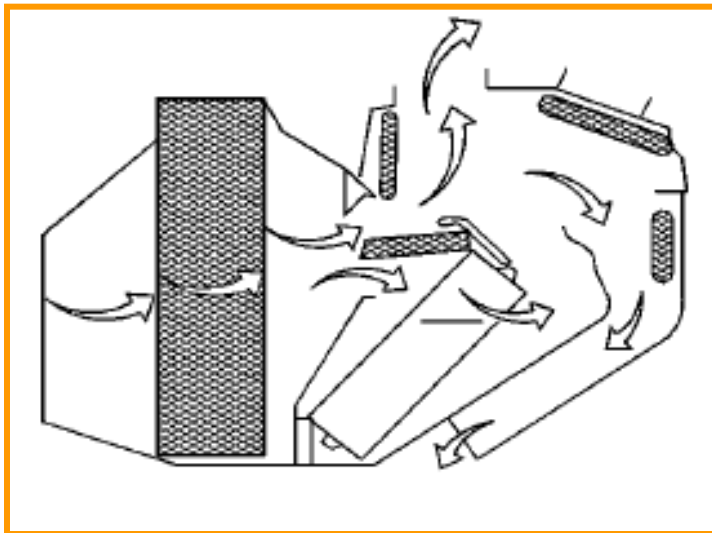

Blowing the foot and defrosting

- Defrosting door work
- Equivalent air passes through the floor outlet and the defrosting outlet

2. Air conditioning and distribution

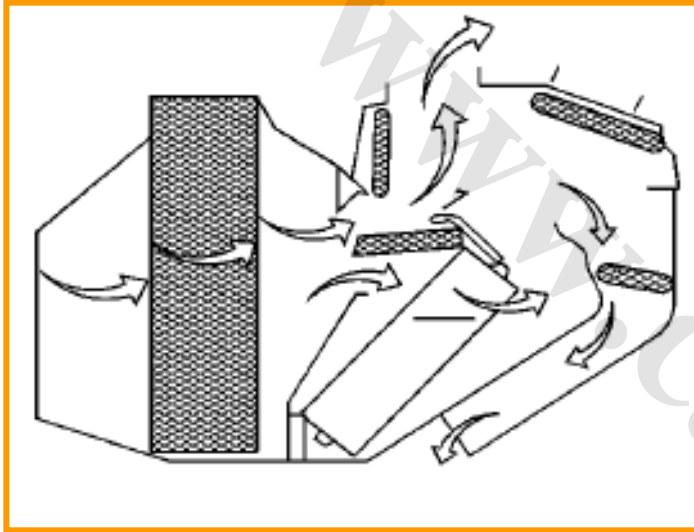

Defrosting

Defrosting door work

Most air passes through the defroster outlet
and a little of air flows through the floor outlet.

3. Overview of the automatic air conditioner

3.1 components of the air conditioner control system

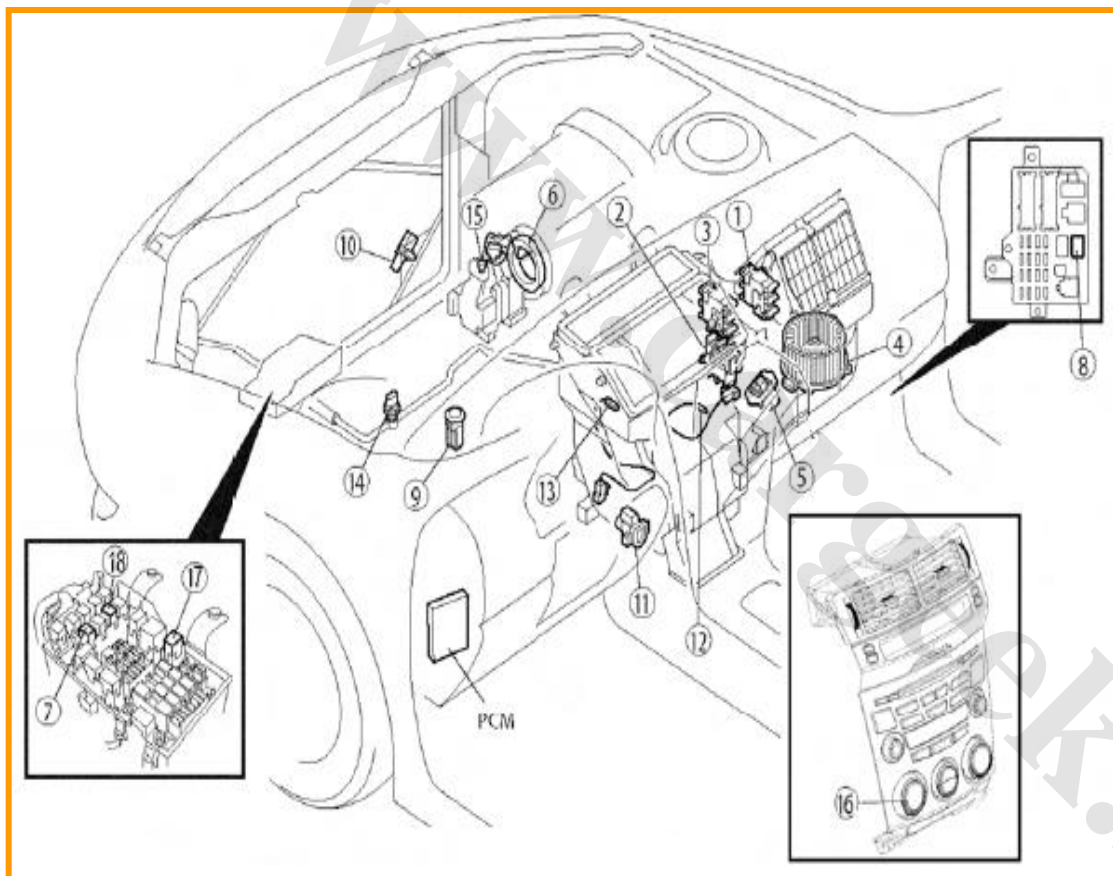

1	Air inletting actuator
2	Air mixing actuator
3	Airflow mode actuator
4	Blower motor
5	Power module
6	Magnetic clutch
7	A/C relay
8	Blower relay
9	Illumination sensor
10	External temperature sensor of the car
11	Internal sensor of the car
12	Temperature sensor of the evaporator
13	Water temperature sensor
14	Refrigerant pressure switch
15	Thermal protector
16	Climate control device
17	TNS relay
18	...

3.2.1 Control panel of manual air conditioner

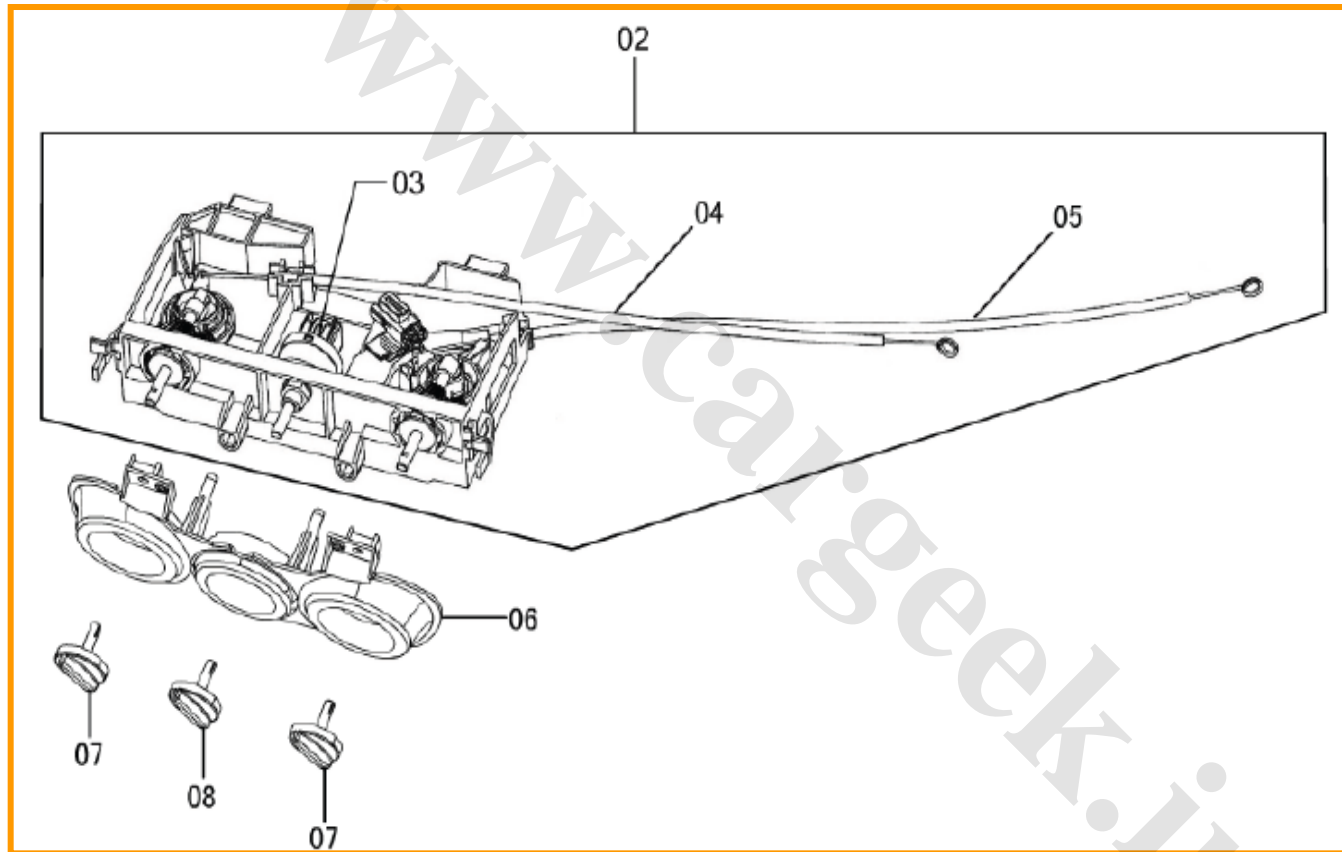

- 02:**mechanism assmby of air conditioner control
- 03:**blower switch assmby
- 04:**door span wire — mode
- 05:**door span wire — temperature
- 06:**sunshade assmby
- 07:**knob
- 08:** fan knob

3. Overview of the automatic air conditioner 中国一汽

www.CarGeek.ir

3.2 .2Control panel of the automatic air conditioner

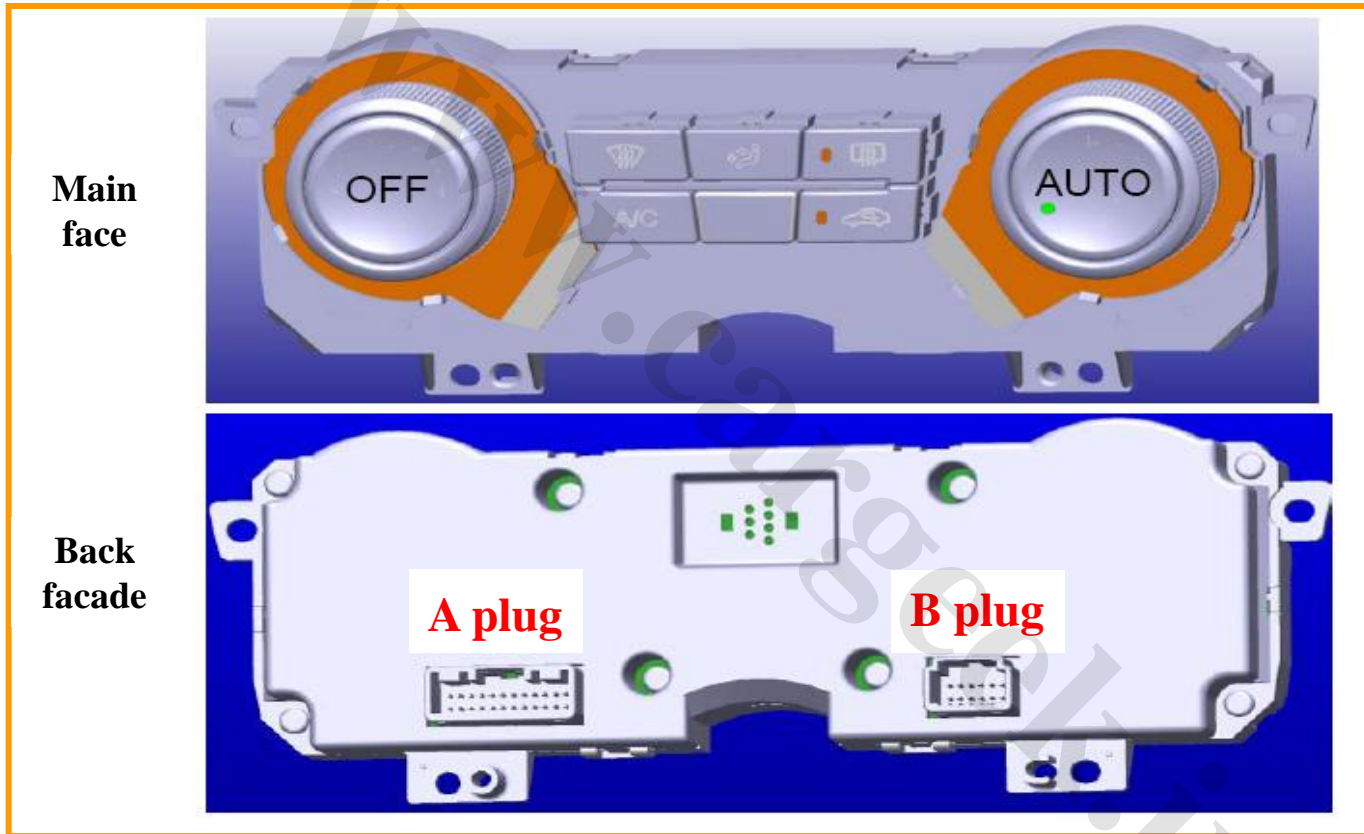

3. Overview of the automatic air conditioner 中国一汽

3.3 Structural composition of the air conditioner control system

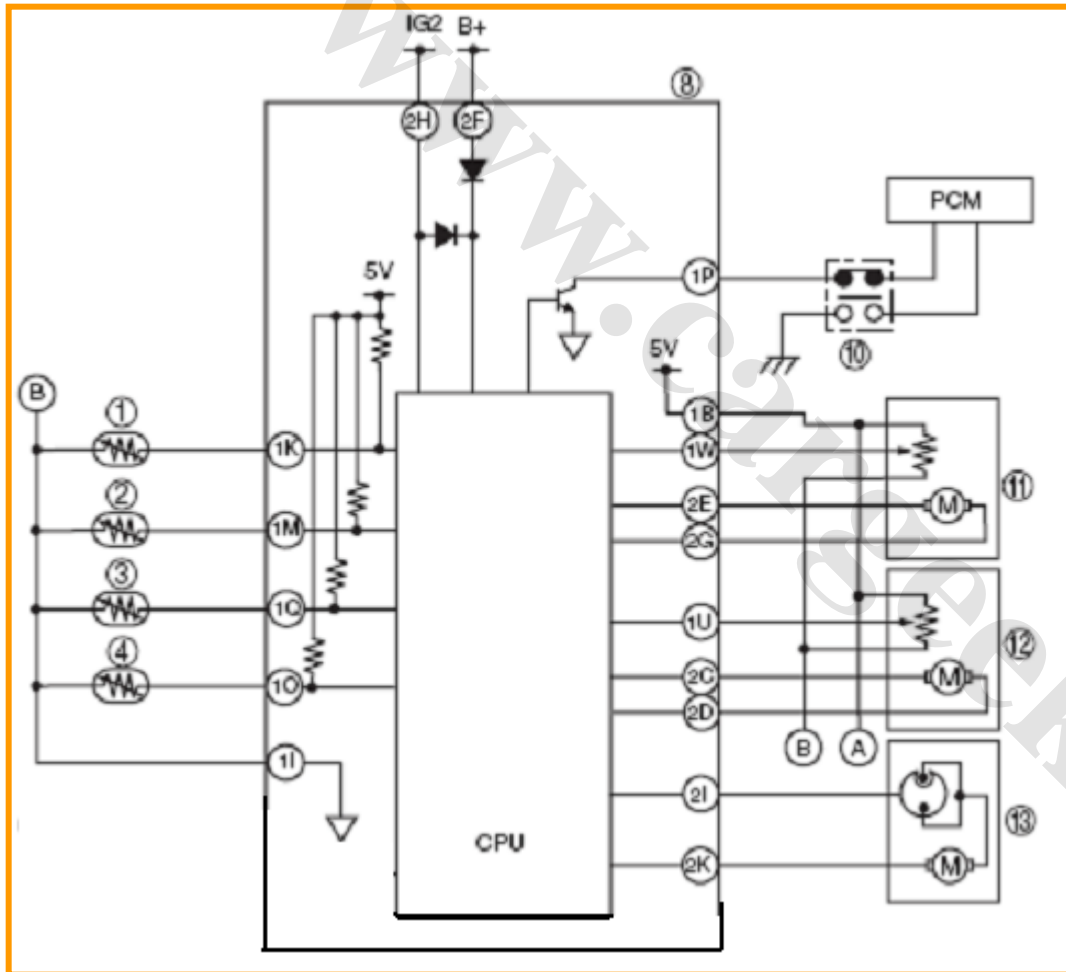

1	External temperature sensor
2	Cabin temperature sensor
3	Temperature sensor of the evaporator
4	Water temperature sensor
5	Solar radiation sensor
6	From TNS relay
7	Panel light control
8	Climate control device
9	Every switch
10	Refrigerant pressure switch
11	Airflow mode actuator
12	Air mixing actuator
13	Air inletting actuator
14	From the blower relay
15	Blower motor
16	Power MOS FET
17	From the rear defogger relay

3. Overview of the automatic air conditioner

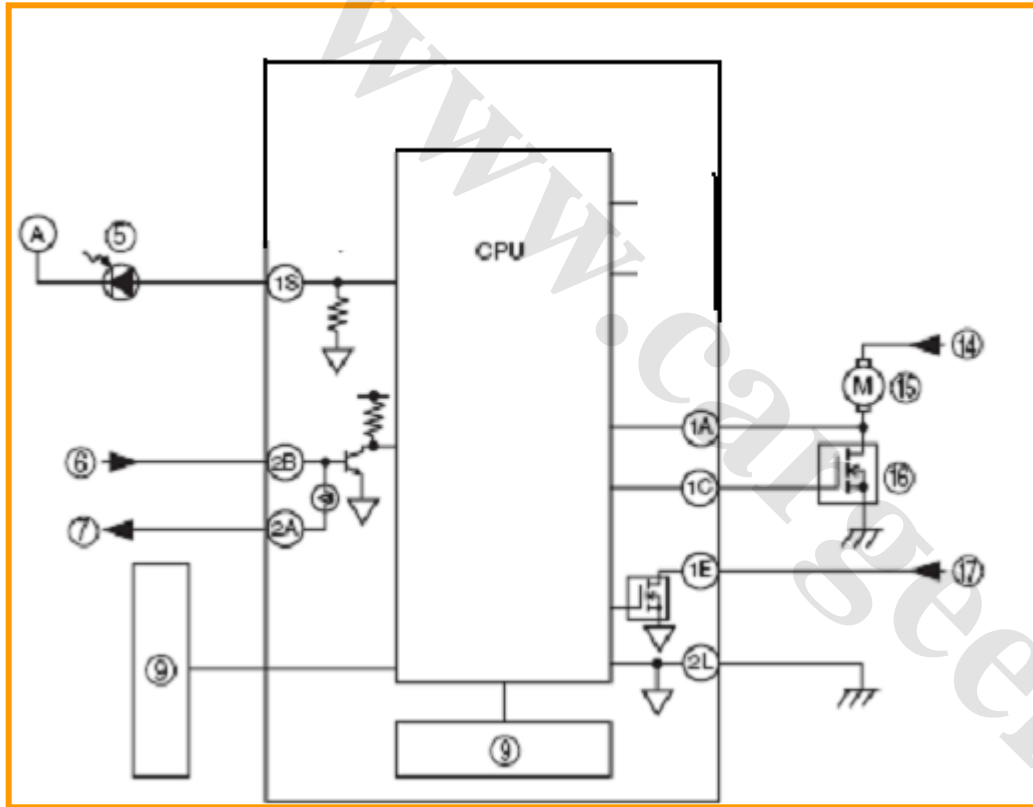

1	External temperature sensor
2	Cabin temperature sensor
3	Temperature sensor of the evaporator
4	Water temperature sensor
5	Solar radiation sensor
6	From TNS relay
7	Panel light control
8	Climate control device
9	Every switch
10	Refrigerant pressure switch
11	Airflow mode actuator
12	Air mixing actuator
13	Air inletting actuator
14	From the blower relay
15	Blower motor
16	Power MOS FET
17	From the rear defogger relay

3. Overview of the automatic air conditioner 中国一汽

3.4 Functions of the fully-automatic air conditioner

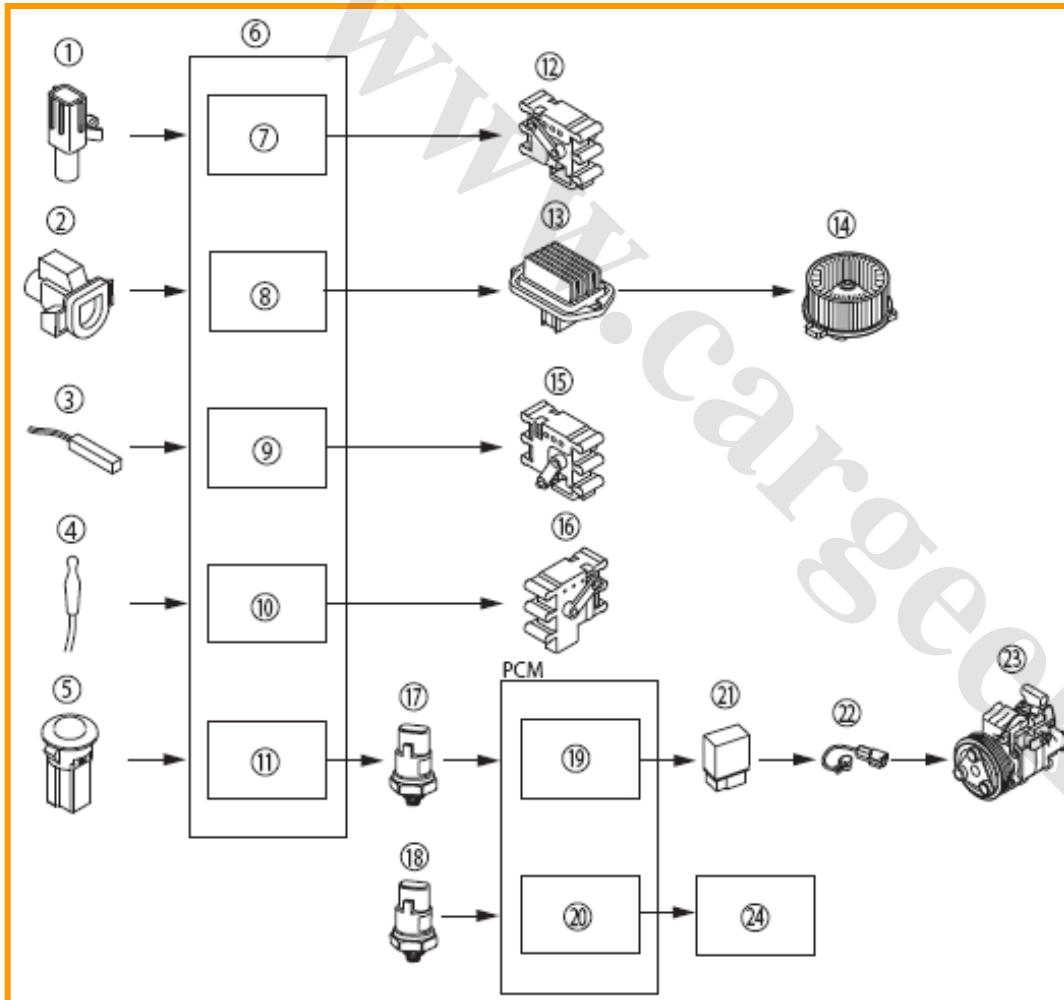

- 1 External temperature sensor
- 2 Cabin temperature sensor
- 3 Water temperature sensor
- 4 Temperature sensor of the evaporator
- 5 Solar radiation sensor
- 6 Weather control device
- 7 Airflow temperature control
- 8 Airflow control
- 9 Airflow mode control
- 10 Air inletting control
- 11 A/C compressor control
- 12 Air mixing actuator
- 13 Power MOS FET
- 14 Blower motor
- 15 Airflow mode actuator
- 16 Inlet actuator
- 17 Refrigerant pressure switch (HI and LO pressure)
- 18 Refrigerant pressure switch (medium pressure) (L3)
- 19 A/C shutoff control
- 20 A/C relay
- 21 Idle air control
- 22 Thermal protector
- 23 Magnetic clutch
- 24 IAC valve

4. Input components of the automatic air conditioner

4.1 Internal temperature sensor



Installation location: in the instrument panel and in the lower left of the driver.

Function: providing the temperature change signals in the car for the air conditioning module.

Working principle: negative temperature coefficient thermistor.

Circuit

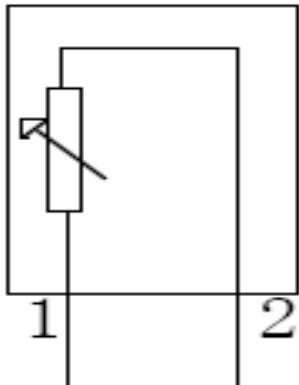

1#: sensor signal negative electrode

2#: sensor signal

Parameter: 2.12K Ω (ambient temperature 25 $^{\circ}$ C)

Inspection method: universal meter, diagnostic apparatus.

4. Input components of the automatic air conditioner

www.CarGeek.ir



4.2 External temperature sensor

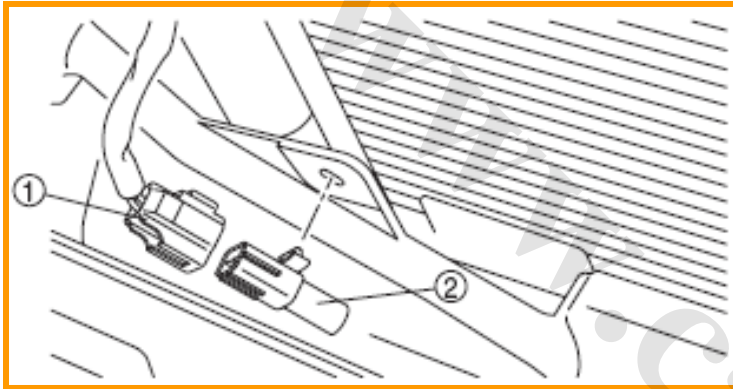

Installation location: in the lower engine hood lock.
Function: Providing ambient temperature signals for the air conditioning module.
Working principle: negative temperature coefficient thermistor.

Circuit

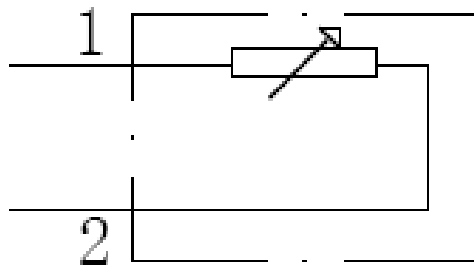

1#: sensor signal negative electrode
2#: sensor signal

Parameter: 1.94K Ω (ambient temperature 25 $^{\circ}$ C)
Inspection method: universal meter, diagnostic apparatus.

4. Input components of the automatic air conditioner

4.3 Solar sensor



Installation location: in the middle of the instrument panel and under the front windshield.

Function: Providing solar radiation intensity signals for the air conditioning module.

Working principle: principle of the photoelectric effect.

Circuit

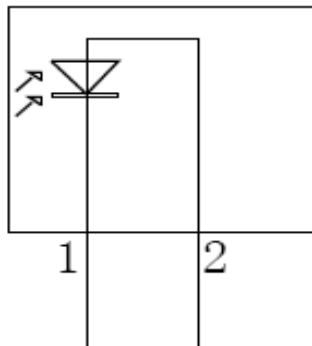

1#: sensor signal negative electrode

2#: sensor signal

Parameter: 10mV without sunshine;

478mV under strong sunshine.

Inspection method: universal meter, diagnostic apparatus.

4. Input components of the automatic air conditioner

4.4 Refrigerant pressure switch

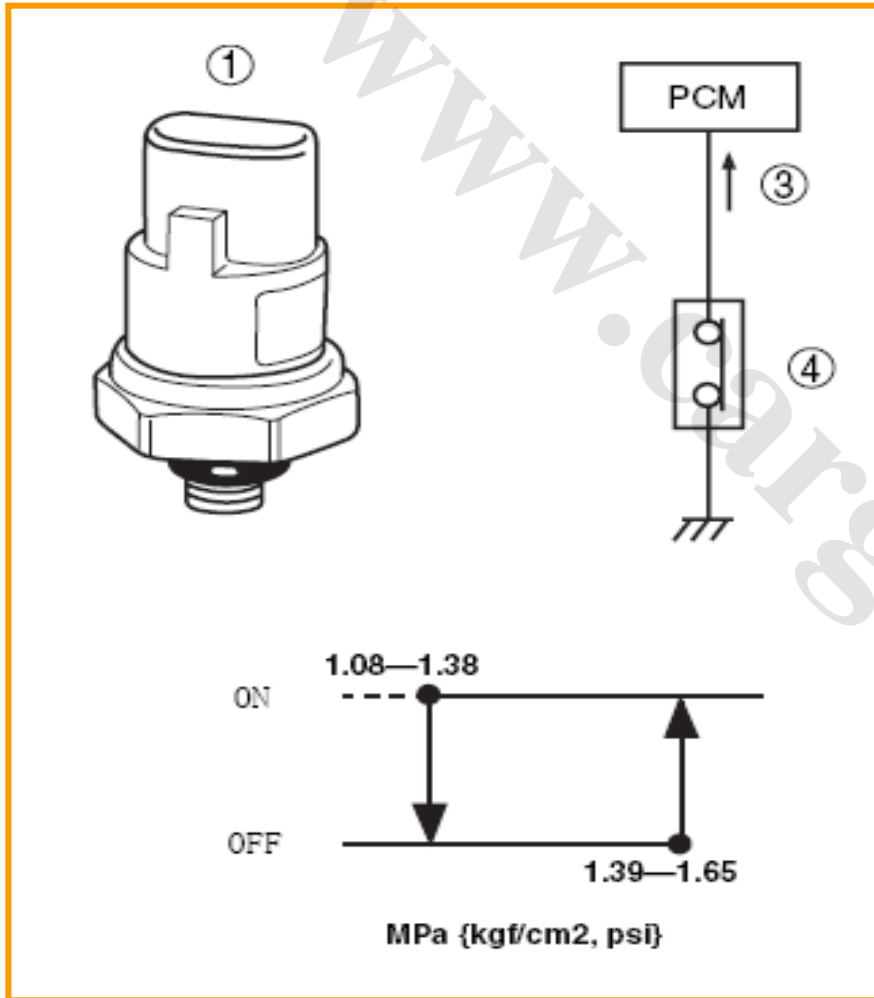

- The three-gear pressure type is adopted. It consists of high/low pressure switch and medium pressure switch.
- The medium pressure switch will output an idle speed increase signal based on the working load of the A/C compressor. When the pressure in the refrigerant circulation is too high or too low, the high/low pressure switch will protect the components of the refrigerating system by cutting off A/C signals.
- When the refrigerant pressure is about 1.39 MPa or higher, the switch will be electrified and the idle speed increase signal is output to PCM.
- When A/C is open and the idle speed increase signal is input to PCM, the IAC solenoid valve will receive an operation signal.

4. Input components of the automatic air conditioner

4.5 Water temperature sensor

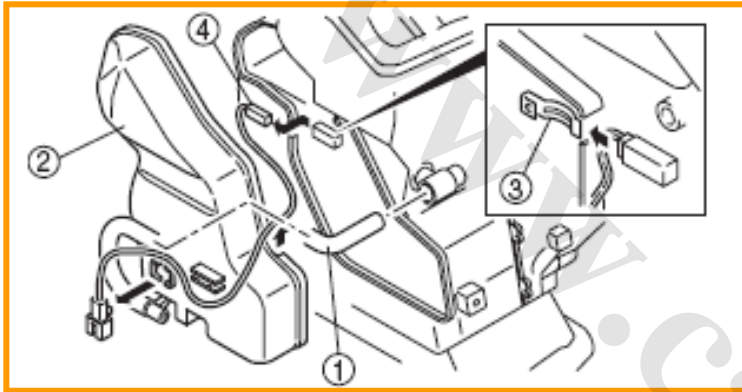

Installation location: under the instrument and in the left of the evaporator.

Function: providing the temperature of the water tank for the air conditioning module.

Working principle: thermistor.

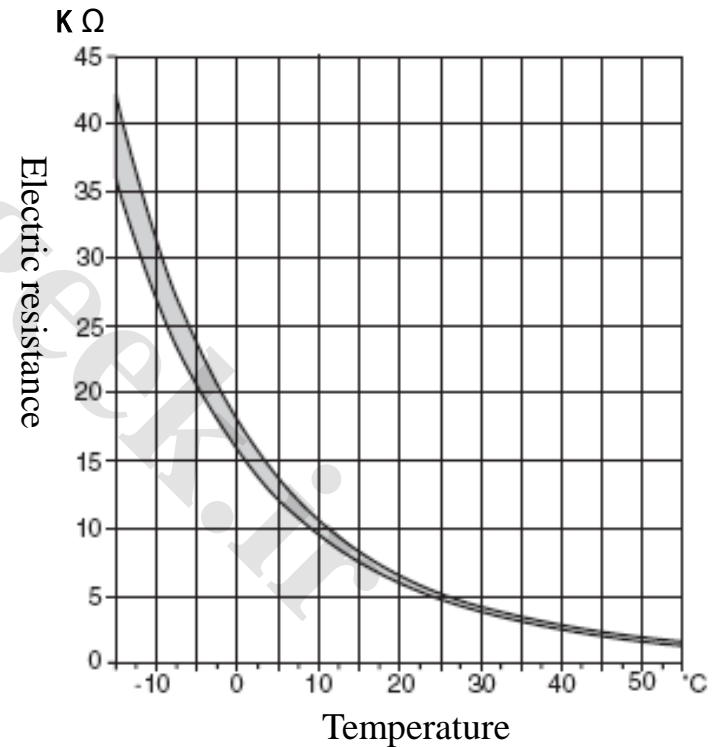
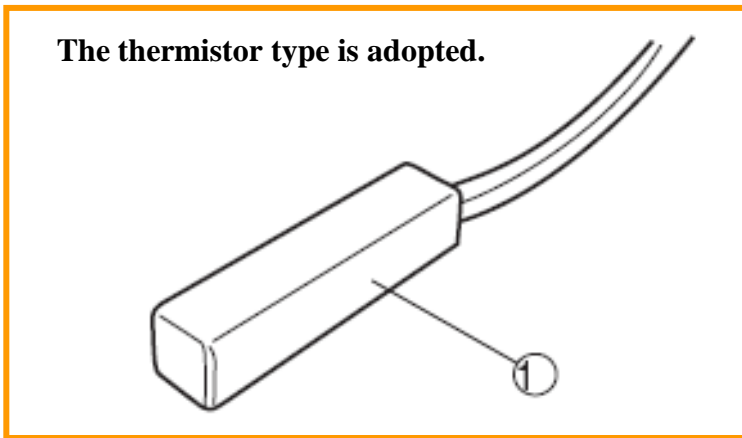

4. Input components of the automatic air conditioner

4.6 Temperature sensor of the evaporator

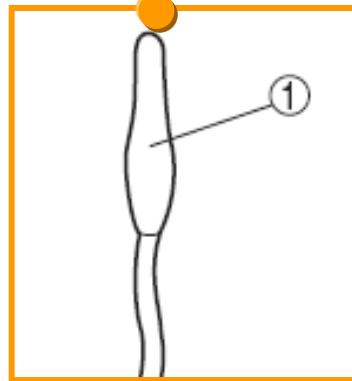
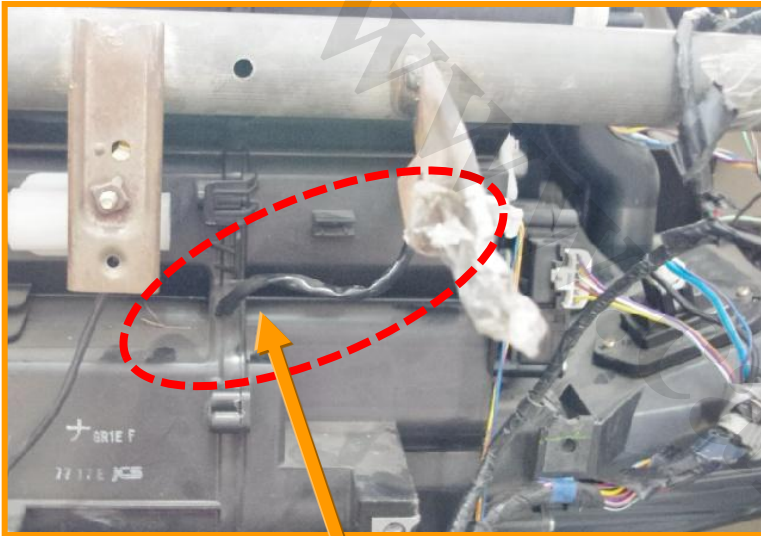

Installation location: under the instrument panel and in the middle of the evaporator.
Function: controlling disconnection and work of the compressor.
Working principle: thermistor.

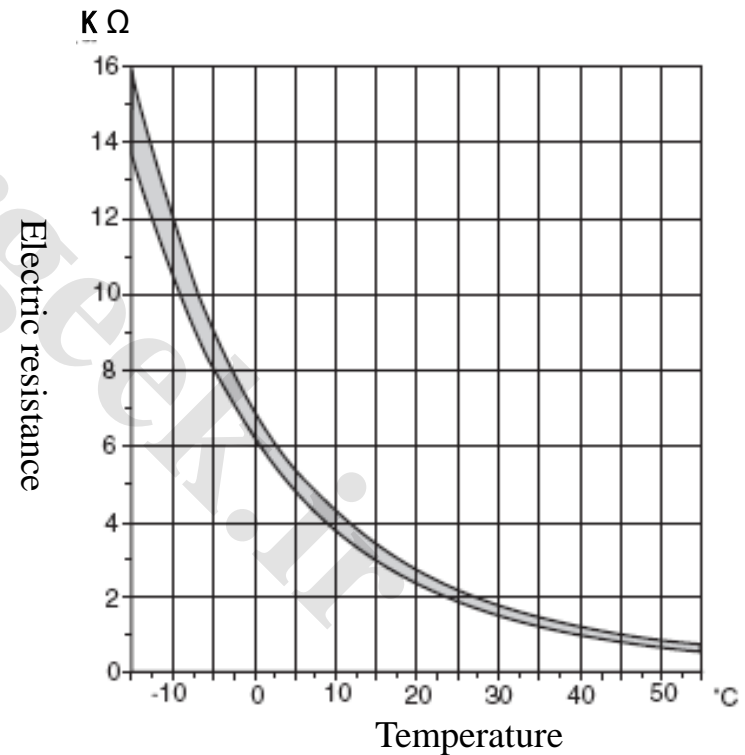

5. Output function of the automatic air conditioner

5.1 Principle drawing of the airflow

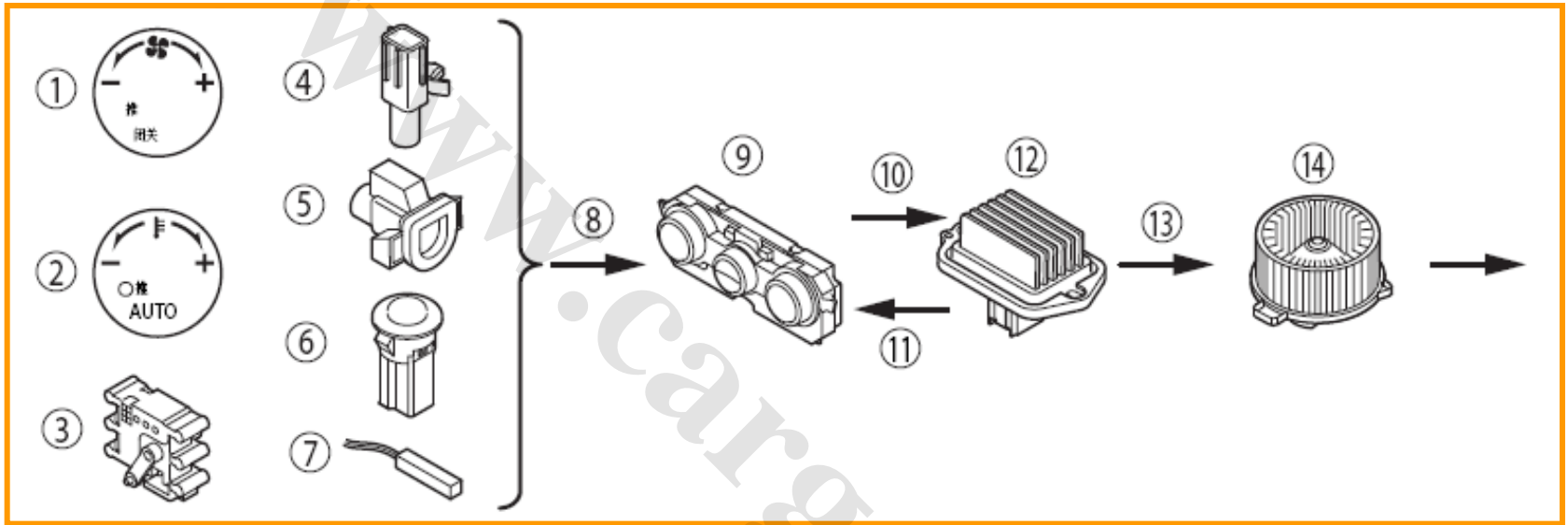

1	Fan switch	6	Illumination intensity	11	Feedback
2	Temperature setting	7	Coolant temperature	12	Power MOS FET
3	Airflow mode	8	Signal	13	Operation
4	External temperature	9	Climate control device	14	Blower motor
5	Cabin temperature	10	Output	15	Airflow change

5. Output function of the automatic air conditioner

5.2.1 Control of the blower

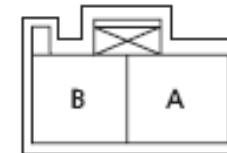
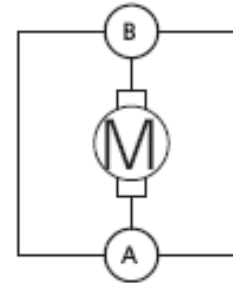
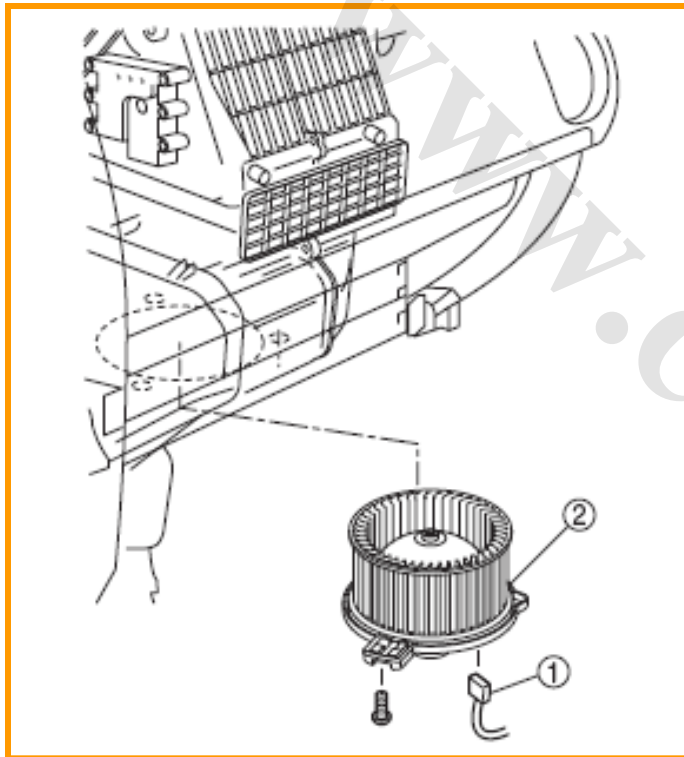

1# Control signal

2#: 12V power supply (R9)

Parameter: 1.1 - 1.2 Ω (ambient temperature 25 $^{\circ}\text{C}$)

Inspection method: universal meter, diagnostic apparatus.

Circuit: its revolution is controlled by the air conditioner control module via the revolution governor.

5. Output function of the automatic air conditioner

www.CarGeek.ir



5.2.2 Speed regulation modules of the blower



Installation location: at the passenger side and under the instrument panel, behind the glove box, on the air passage.

Function: controlling the revolution of the blower.

Working principle: semiconductor module.

Circuit: signals of the governor are provided by the air conditioner control module.

5. Output function of the automatic air conditioner

Circuit: signals of the governor are provided by the air conditioner control module.

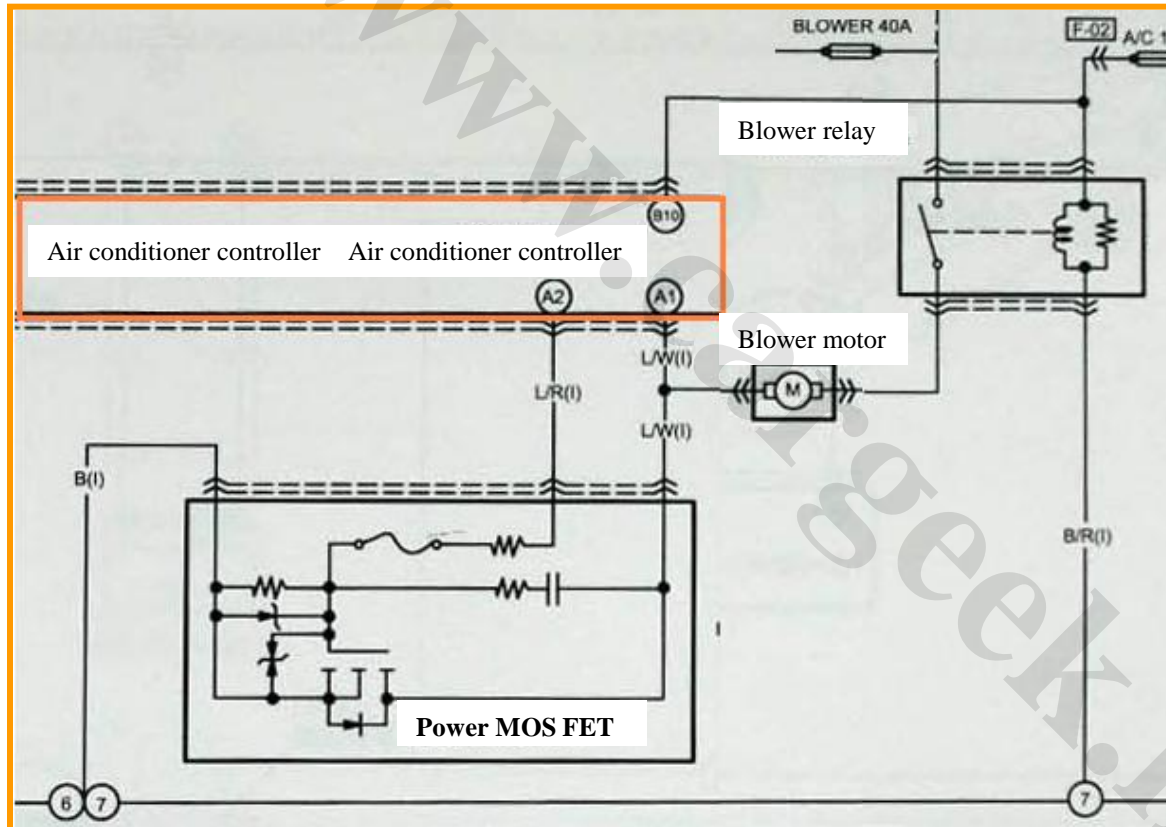

A#: earth
 B#: blower output control
 E#: control signals of the control panel

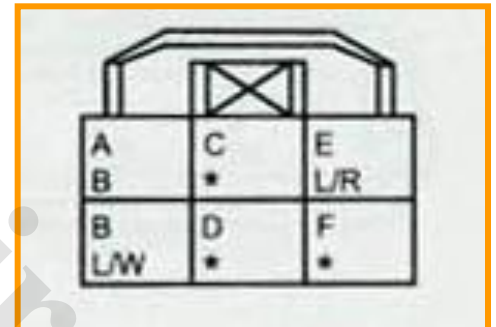

5. Output function of the automatic air conditioner

5.3.1 Schematic diagram of air inletting control system

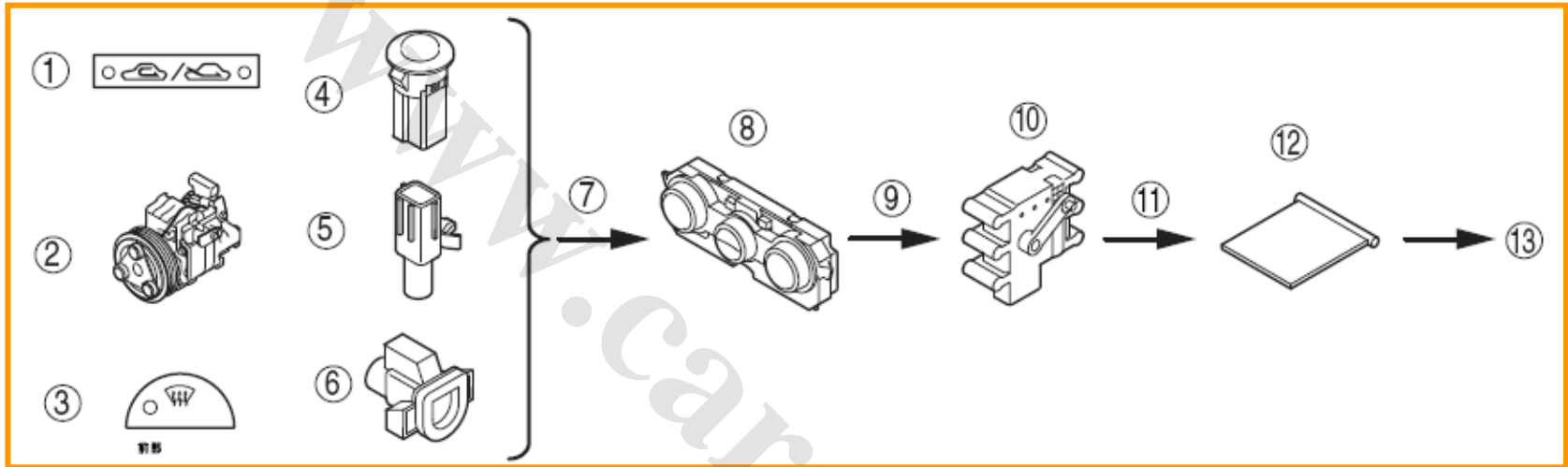

1	REC/FRESH switch	8	Climate control device
2	Control condition of the A/C compressor	9	Output
3	DEF switch	10	Air inletting actuator
4	Illumination intensity	11	Operation
5	External temperature	12	Air inflow door
6	Cabin temperature	13	Air inflow mode change
7	signal		

5. Output function of the automatic air conditioner

5.3.2 Air inflow automatic control and modification

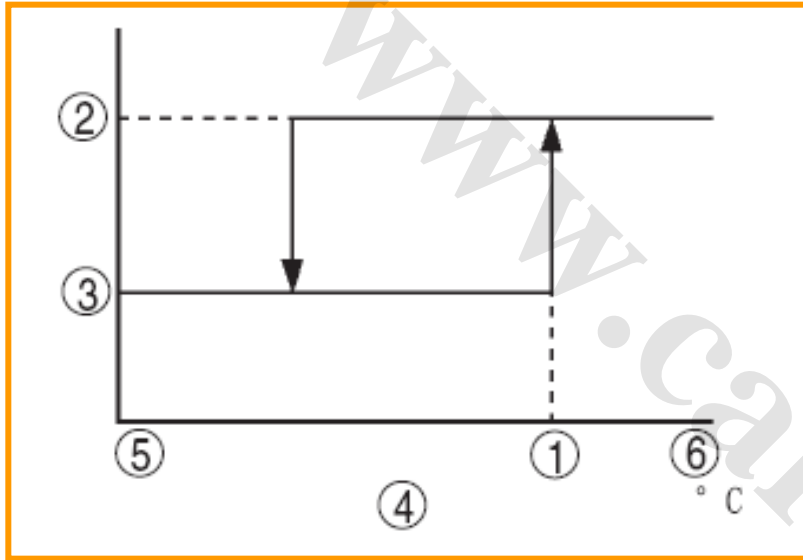

1 Calculated values of the cabin temperature

2 REC

3 FRESH

4 Cabin temperature

5 Low

6 High

- Max cold adjustment
 - When the temperature is set at 18.0° C, the air inflow mode is fixed in the REC mode, consequently improving the cooling effect. When the defrosting adjustment is opened or the A/C compressor is in the closing mode or the external temperature is lower than 5° C, this adjustment does not work.
- Defrosting adjustment
 - When DEF switch is opened, the air inflow mode is fixed in the FRESH mode to improve the defrosting effect.
- External temperature adjustment
 - When the external temperature is 5° C or lower, the air inflow mode is fixed in the FRESH mode to prevent the windshield and front door and window glass from fogging.
- A/C OFF modification
 - When the air inflow mode is in the automatic control mode and the A/C close mode, the air inflow mode is fixed in the FRESH mode.

5. Output function of the automatic air conditioner

5.4 Internal and external circulation door motor



Installation location: at the passenger side and in the lower right of the instrument panel, behind the glove box and in the right of the air passage.

Function: driving internal and external circulation doors.

Working principle: motor.

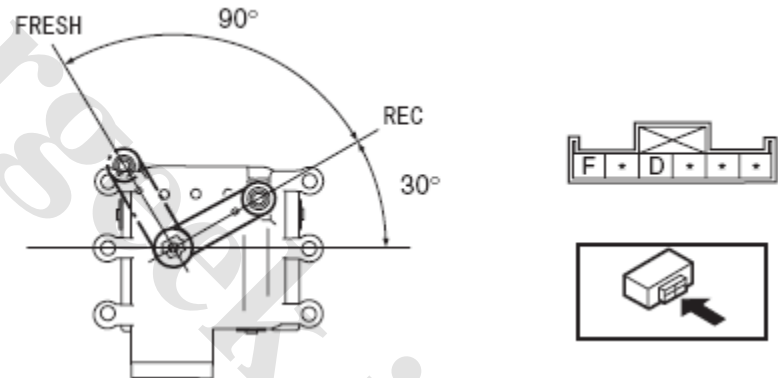

Circuit

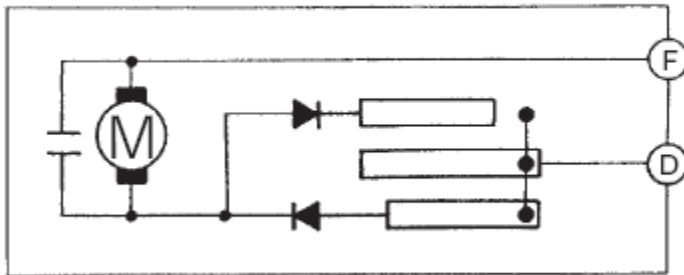

F#: positive electrode of the motor

D#: negative electrode of the motor

5. Output function of the automatic air conditioner

5.5 Airflow mode principle drawing

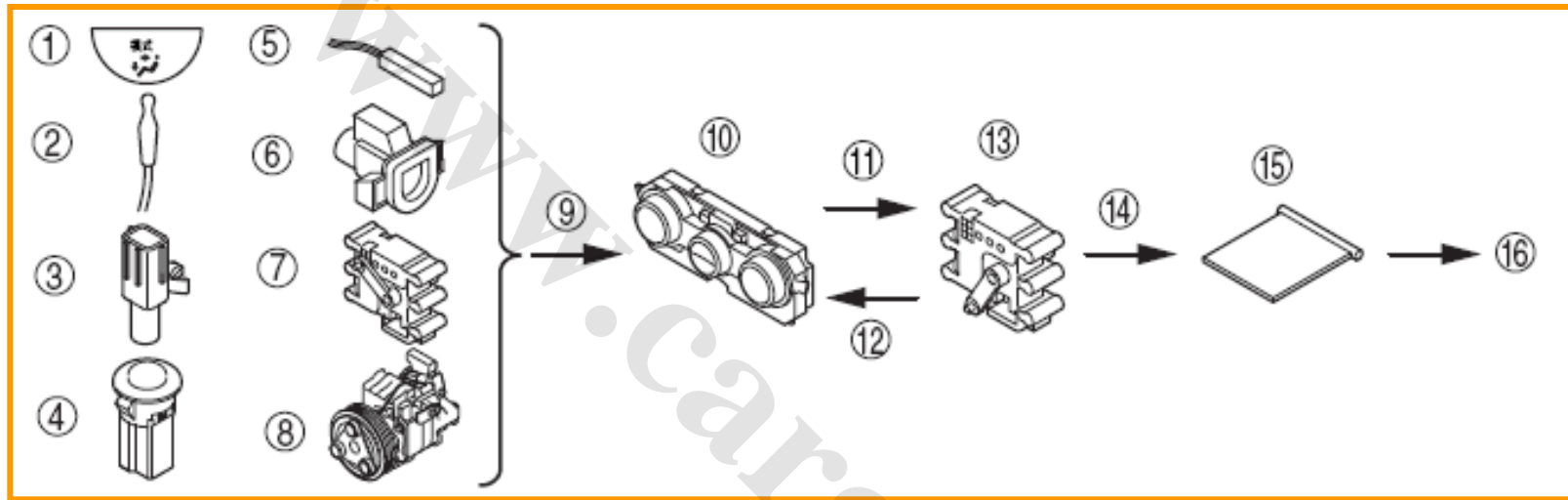

- 1 mode switch
- 2 Temperature sensor of the evaporator
- 3 External temperature sensor
- 4 Solar radiation sensor
- 5 Coolant temperature
- 6 Cabin temperature

- 7 Opening angle of the air mixing actuator
- 8 Control condition of the A/C compressor
- 9 Signal
- 10 Weather control device
- 11 Output
- 12 Feedback

- 13 Airflow mode actuator
- 14 Operation
- 15 Airflow mode door
- 16 Airflow mode change

5. Output function of the automatic air conditioner

➤ Automatic control and adjustment of the air conditioner

- The climate control device will determine the airflow mode through the current opening angle of the air mixing actuator and the control condition of the A/C compressor. When the A/C compressor is in closed, the climate control device will change the defined valve of the airflow mode based on the signals received from the temperature sensor of the evaporator.

➤ External temperature adjustment

- In order to prevent the windshield and front door and window glass from fogging, the airflow mode is fixed in the heating/defogging mode when the external temperature is too low. However, when the temperature is set at MAX cold, the external temperature modification will not work. (The temperature setting scale deflects to the left.)

➤ Temperature adjustment of the engine coolant (preheating adjustment)

- In winter, after the engine is started, the airflow mode will be changed according to the temperature rise of the engine coolant to avoid uncomfortable sense caused by cold air blowing to the feet. Only when the cabin temperature is 13° C or lower or when the cabin temperature is 23° C or lower and the illumination intensity is relative low, the temperature adjustment of the engine coolant will start to actuate.

5. Output function of the automatic air conditioner

5.6 Mode door motor



Installation location: in the left bottom of the passage.

Function: driving two mode doors.

Working principle: motor + potentiometer.

Circuit

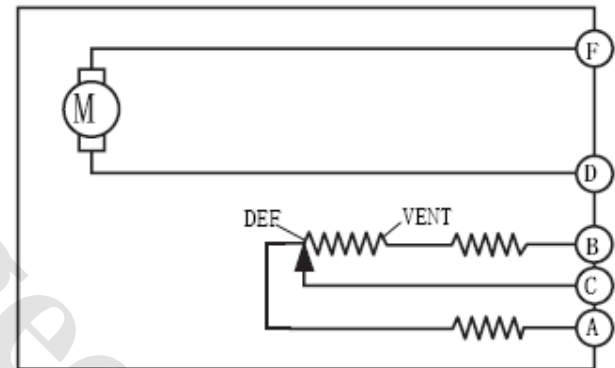
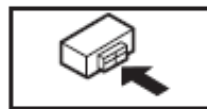
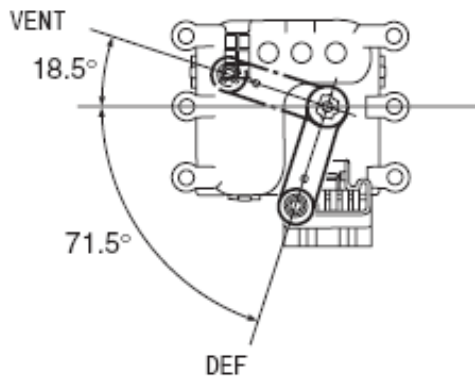

A#: Position sensor power supply + 12V

B#: Position sensor signal negative electrode

C#: Position sensor signal

D#: negative electrode of the motor

F#: positive electrode of the motor

5. Output function of the automatic air conditioner

5.7 Mixing door temperature control principle drawing

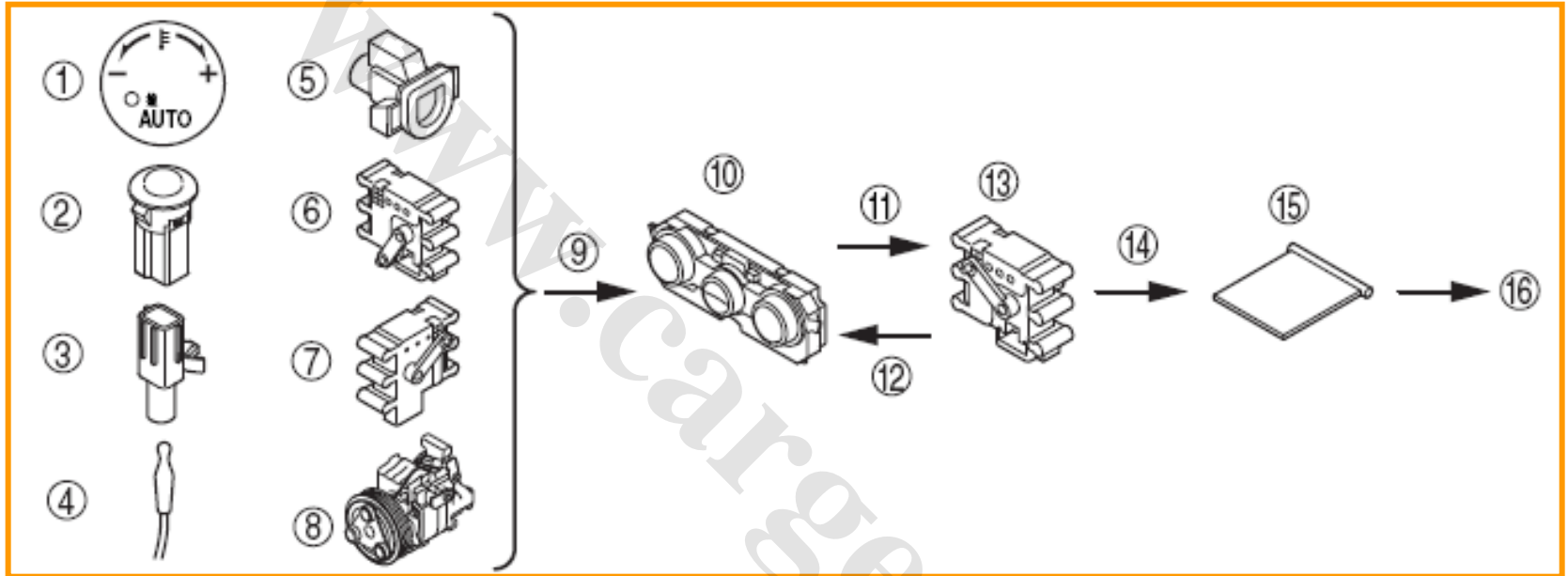

- 1 Setting temperature
- 2 Illumination intensity
- 3 External temperature
- 4 Evaporator temperature
- 5 Cabin temperature

- 6 Airflow mode
- 7 Air inletting mode
- 8 Control condition of the A/C compressor
- 9 Signal
- 10 Climate control device

- 11 Output
- 12 Feedback
- 13 Air mixing actuator
- 14 Operation
- 15 Air mixing door
- 16 Airflow temperature change

5. Output function of the automatic air conditioner

5.8 Airflow temperature control operation

➤ Air inflow adjustment

- When the A/C mode is closed, the opening angle of the air mixing actuator is modified to avoid the airflow temperature increase caused when the air inflow mode is switched from external circulation to internal circulation. In addition, this modification delays the operation of the air mixing actuator to avoid sudden drop of the airflow temperature.

➤ A/C modification

- When the A/C compressor is switched from the A/C ON mode to the OFF mode, the basic opening angle of the air mixing actuator will be switched from the opening angle of the A/C ON mode to that of the A/C OFF mode. To avoid the airflow temperature increasing. In addition, this modification delays the operation of the air mixing actuator to avoid sudden drop of the airflow temperature.

➤ Max hot and max cold adjustment

- When the temperature is set at MAX HOT (the temperature setting scale points to the right), the air mixing actuator is fully opened (100%). When it is set at MAX COLD (the temperature setting scale points to the left), the air mixing actuator is tightly closed.

➤ Coolant temperature adjustment

- In some cases, when the external temperature is extremely low, continuous idle operation will cause very low temperature of the engine coolant. In this case, in order to avoid too low airflow temperature, the climate control device will adjust the hot air mixing actuator to open according to the temperature of the engine coolant. However, when the external temperature is above 10° C, the coolant temperature modification function will not work.

5. Output function of the automatic air conditioner

5.9 Mixing door motor

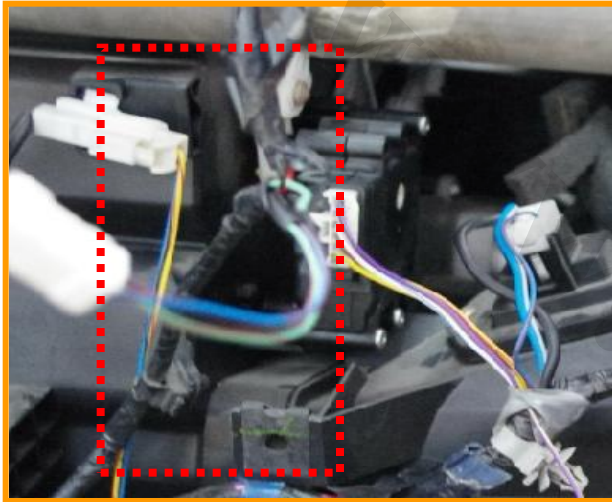

Installation location: in the left bottom of the passage.

Function: drive the mixing door.

Working principle: motor + potentiometer.

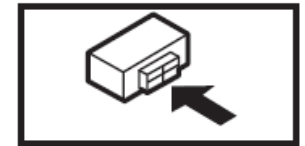
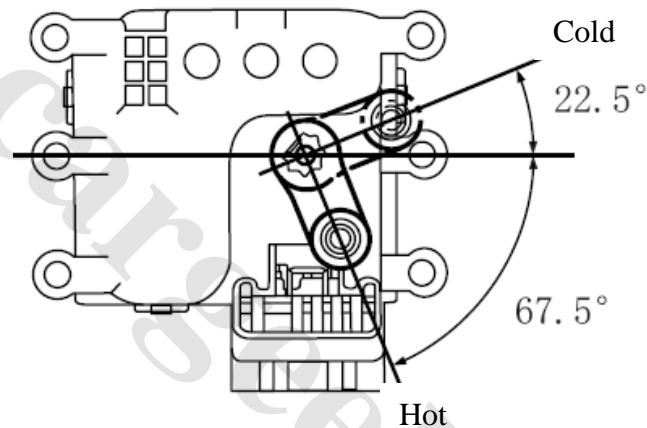

Circuit

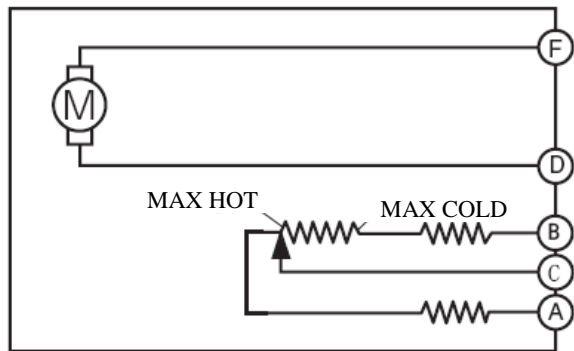

A#: Position sensor power supply + 12V

B#: Position sensor signal negative electrode

C#: Position sensor signal

D#: negative electrode of the motor

F#: positive electrode of the motor

5. Output function of the automatic air conditioner

5.10.1 Control of the compressor

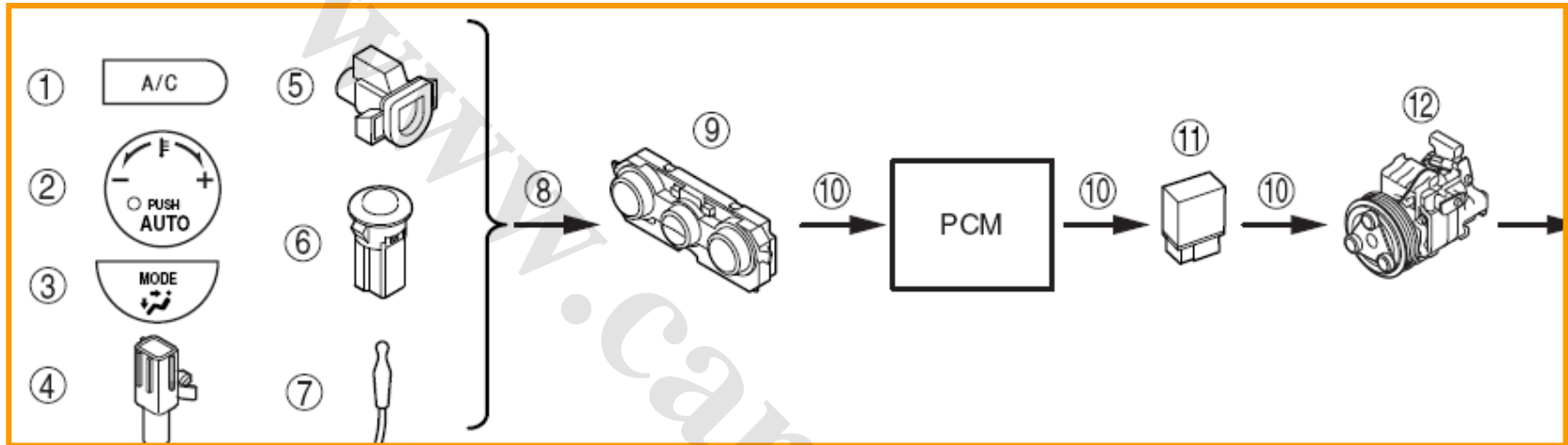

- 1 A/C switch
- 2 Temperature setting
- 3 MODE switch
- 4 External temperature
- 5 Cabin temperature
- 6 Illumination intensity

- 7 Evaporator temperature
- 8 Signal
- 9 Weather control device
- 10 Output
- 11 A/C relay
- 12 A/C compressor

5. Output function of the automatic air conditioner

www.CarGeek.ir



Continued

The compressor of the car air conditioning system is controlled by the engine control module which will determine whether to combine with the clutch relay of the air conditioner by referring to the following signals:

- The air conditioner module sends out request signals to the engine module via CAN BUS.
- Water temperature of the engine
- Signals of high/low pressure and medium pressure switches of the air conditioner
- Outdoor temperature signal
- Working conditions of the engine etc.

5. Output function of the automatic air conditioner

5.10.2 Control circuit diagram of the compressor

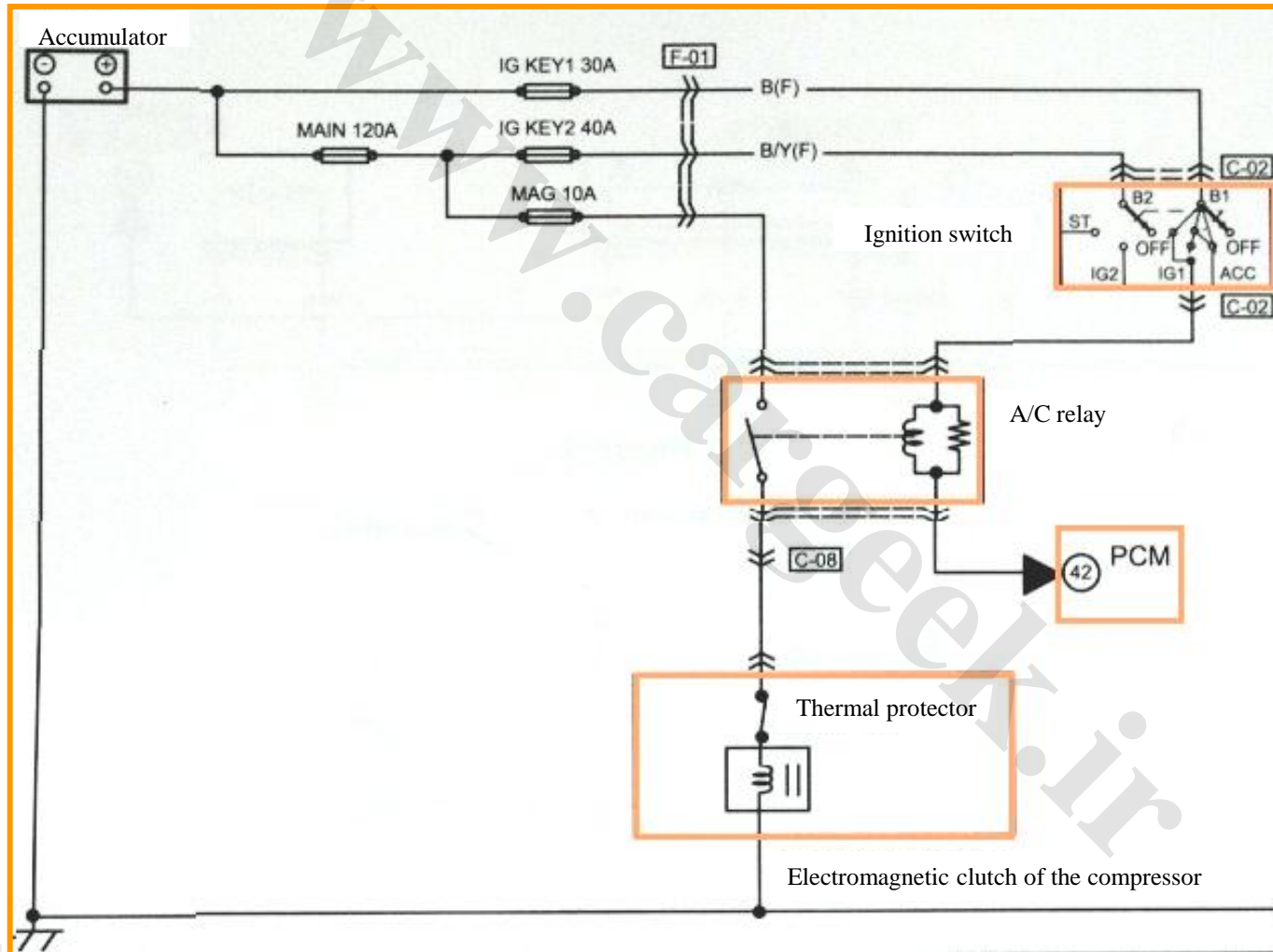

5. Output function of the automatic air conditioner

5.10.3 A/C compressor automatic control

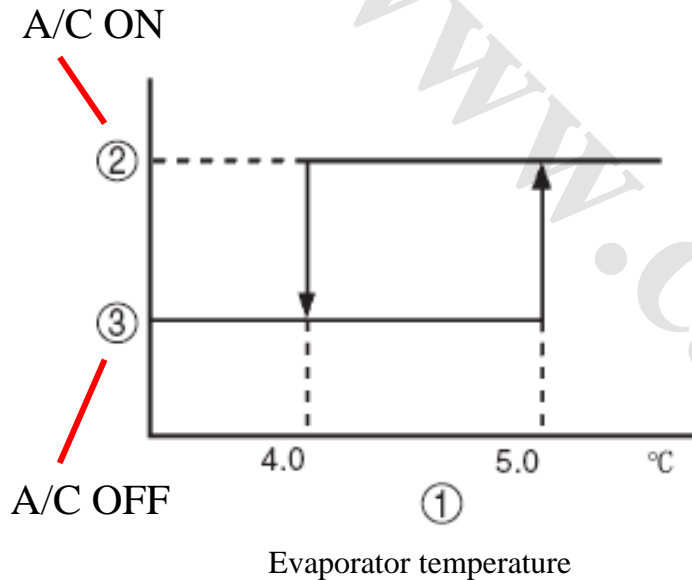

- The climate control device determines the opening/closing mode of the A/C based on the external temperature.
- When the A/C is in the opening mode, the calculated value of the external temperature will be calculated based on the external temperature, the set temperature and measured temperatures from all sensors. This temperature value is used to determine the temperature of air passing through the evaporator. This air temperature is used to determine whether the weather control device shall be opened or the electromagnetic clutch shall be closed (A/C signal).
- When the external temperature is too high/too low, the climate control device will reduce/increase the closing temperature of the electromagnetic clutch, consequently improving the cool comfort level.

5. Output function of the automatic air conditioner

5.10.4 Modification of A/C compressor automatic control

- Defrosting adjustment
 - When the defrosting adjustment is opened, select the A/C mode and set the A/C signal opening/closing temperature at 5.0° C/4.0° C to improve the defrosting performance. During the adjustment of the external temperature, the defrosting adjustment does not work.
- External temperature adjustment
 - When the external temperature is below -5° C, the A/C compressor will be adjusted to fix in the OFF mode to protect the A/C compressor (that is, avoiding the A/C compressor liquid slugging). When the A/C switch is pushed down, only the indicator displays and the A/C compressor will not work
- Defogging adjustment of the windshield
 - When the heater is started in winter, in order to avoid air blown out by the defrosting device forming fog on the windows, close the blower motor and the A/C signal output for 6s after opening the igniter switch. During the airflow automatic control, this control works only when the airflow is in the heating, heating/defrosting or defrosting mode.
- Max cold adjustment
 - When the temperature is set at MAX COLD (the temperature setting scale turns to the left), the A/C signal opening/closing temperature is 5.0° C/4.0° C. During the ambient temperature adjustment, the MAX COLD adjustment does not work

5. Output function of the automatic air conditioner

5.10.5 the self-diagnosis of automatic air conditioner

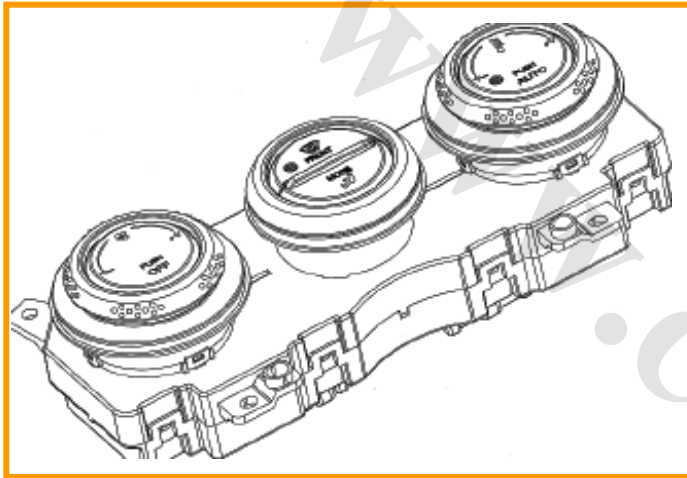

air conditioner control moduel plugs

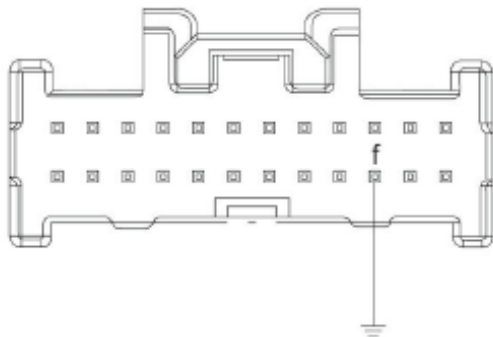

- Using a wire connect F terminal that is in left diagram of the checking connector to ground.
- Turn the ignition switch on, this operation can enter the self -diagnosis mode, and display current faults.
- In the current faults display mode, press A/C switch shift to the past faults display mode
- Through observe climate control device.
- DTC is read by the flicker of the front window defogger indicator.

5. Output function of the automatic air conditioner

5.11 Electric drawing of the automatic air conditioning controller

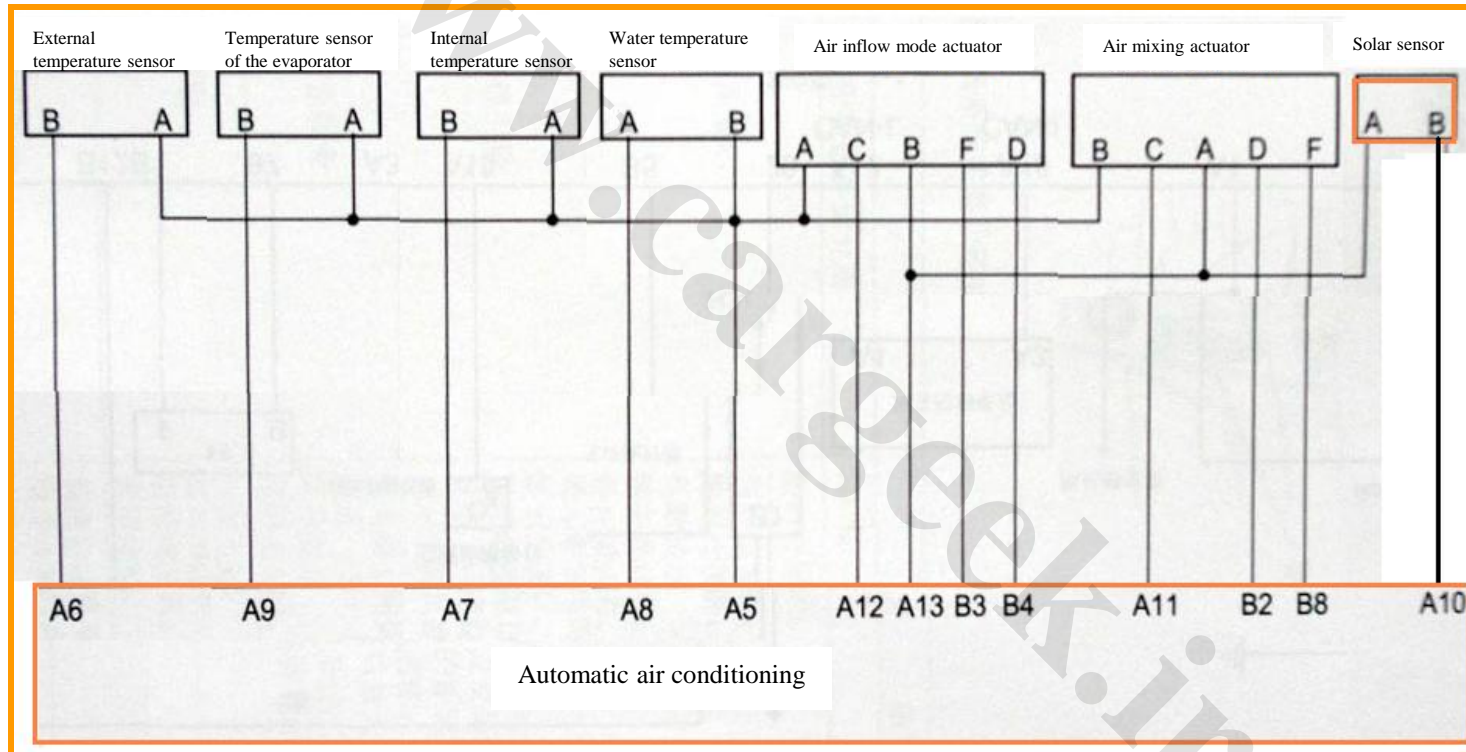

5. Output function of the automatic air conditioner

Continued table above

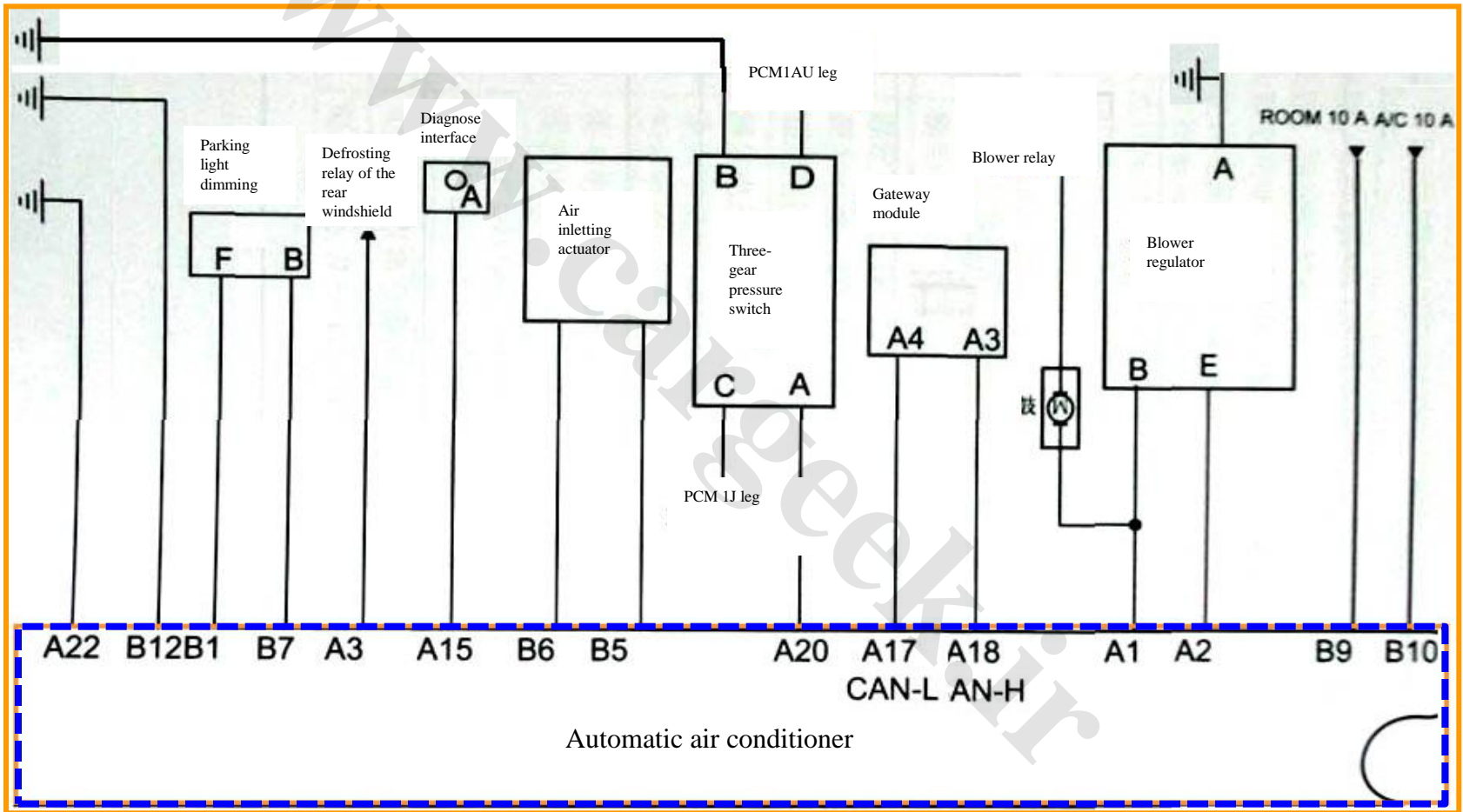

www.cargeek.ir
Thank you !

Technical Training of BESTURN B50

— Car body electrical system (a)

奔腾 BESTURN

Suitable post: Technical director

Internal data, please do not disclose it externally

Curriculum Goals

- To understand basic information about the car body electrical system
- To master the reading method of the circuit diagram
- To know about the position, function and characteristics of various components of the body electrical system
- To master the methods to maintain and diagnose various components of the body electrical system

Contents

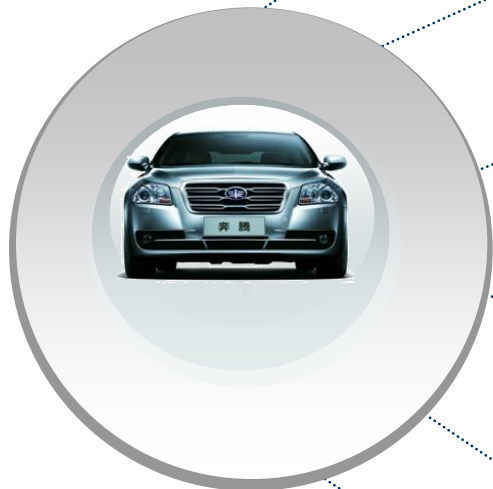

1. Central locking control and antitheft alarm

2. Electric window system

3. Sunroof system

4. Electric rearview mirror

5. Electric memory seat

6. Interior lighting system

1.1 Positions of the elements of the car body remote control/security system

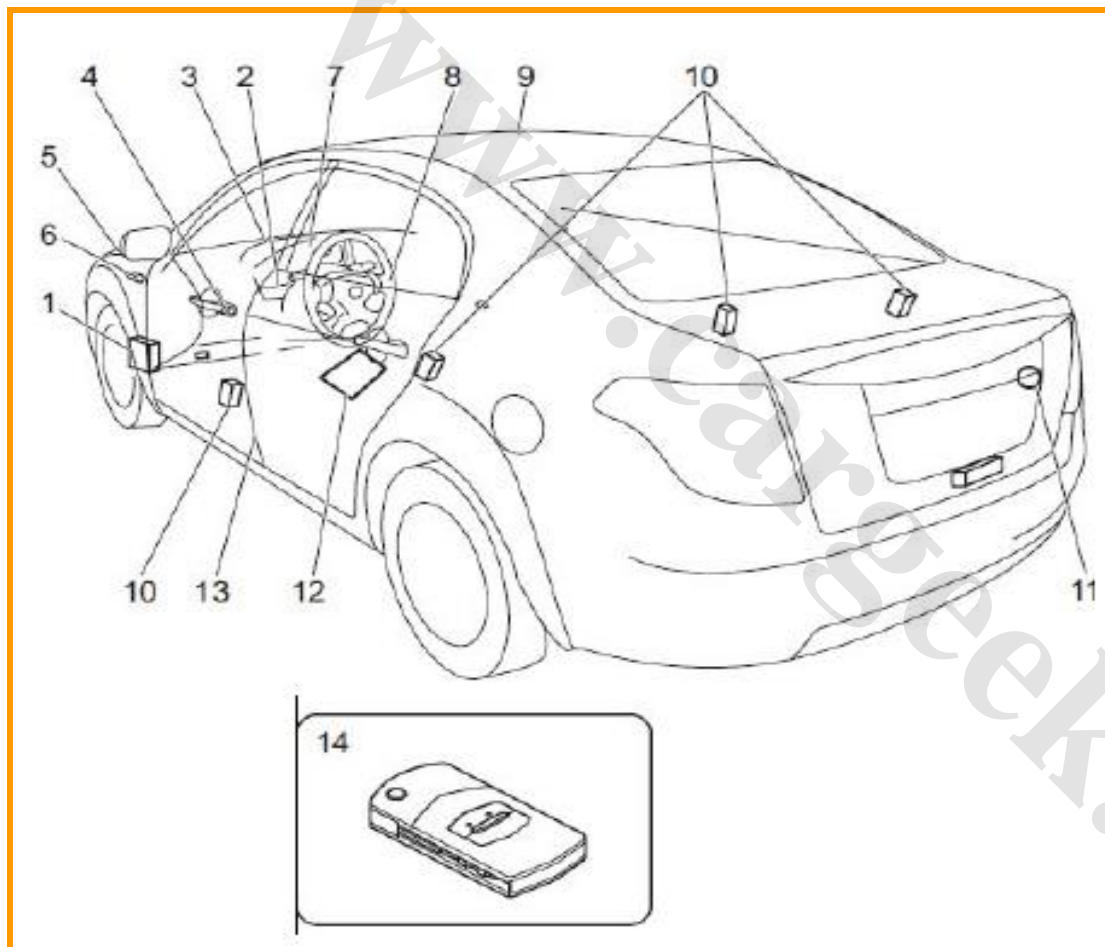

- 1 Body control module
- 2 antitheft control module
- 3 Flashing relay
- 4 front left Door Lock switch
- 5 Horn relay
- 6 side turn signal light
- 7 Instrument cluster
- 8 Ignition switch
- 9 Interior light
- 10 Door lock
- 11 Luggage carrier hood lock opener
- 12 Airbag ECU
- 13 Door switch
- 14 Remote controller

1. Central locking control and antitheft alarm

1.2 Schematic diagram of B50 central locking control

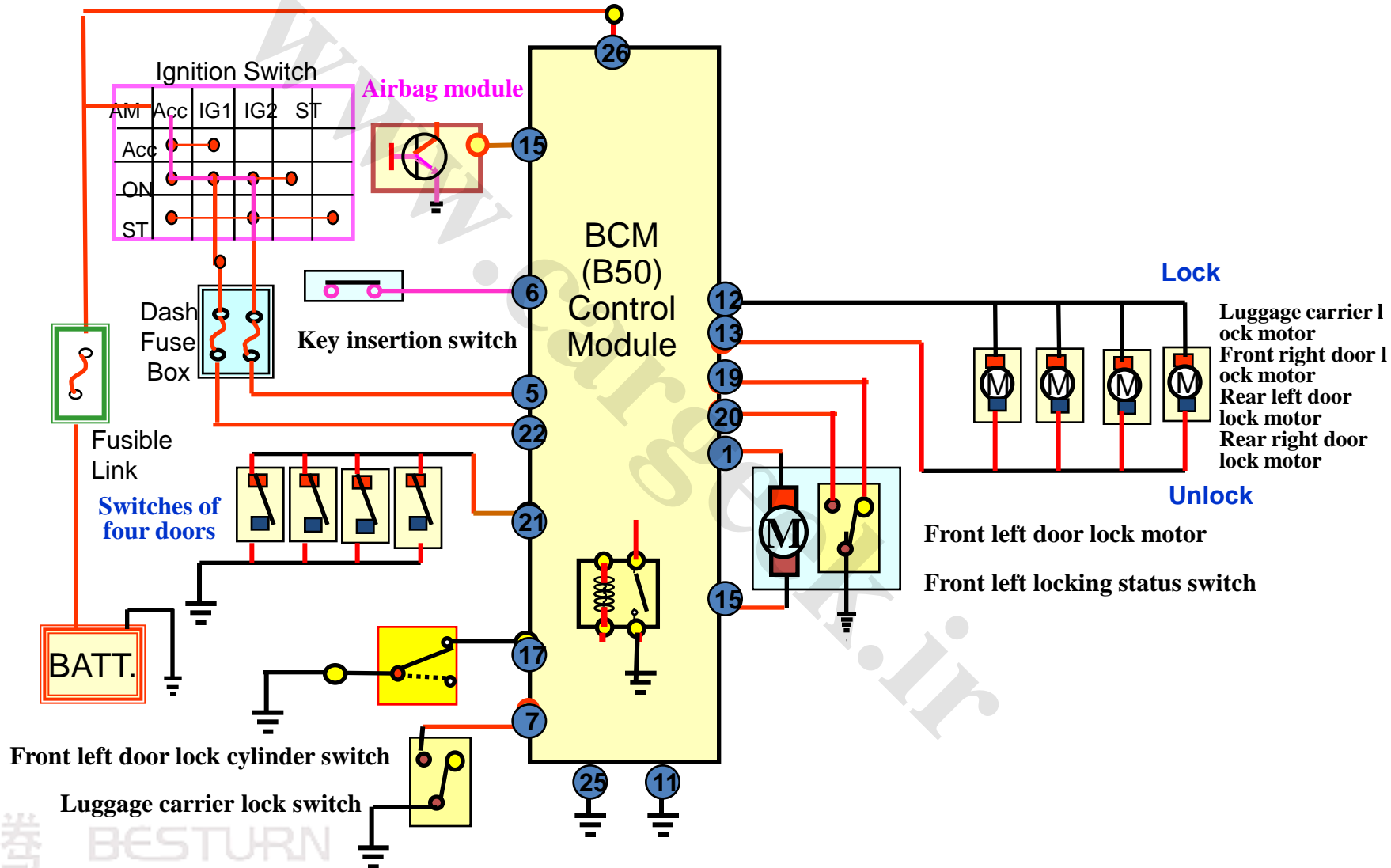

1.3 Functions of the mechanical key

- Pull the key out of the ignition switch, four doors and two hoods all are closed. Use the key to lock the front left door, all door lock motors are locked and all turn signal lights flash once.
- Pull the key out of the ignition switch. When the front left door is closed, no matter what the status of other doors and two hoods, use the key to lock the front left door, all locks are locked and no steering light flashes. After four doors and two hoods are totally closed, all steering lights will flash once. Use the key to unlock the front left door once, only the front left door is unlocked and the steering lights flash twice.
- Use the key to unlock the front left door twice or more times within 1s, in the first time, the front left door is unlocked and in the second time, all other door locks (including luggage carrier lock) are unlocked and the turn signal lights flash twice.

1.4 Remote control key



- Execution of mechanical unlocking and locking of the doors, operation of the ignition switch.
- Remote unlocking and locking of the doors and opening of the luggage carrier.
- Alarm setting and release.
- Engine antitheft function.
- Automatic locking function: While using the remote control key to unlock, the car will be automatically locked if the driver door is not opened within one minute.
- Learning and memory is required to replace the remote control transmitter.
- There is no dead zone within 10 meters of the signal transmitted from the remote controller. The maximum active range is about 30 meters.
- If the active distance of the remote controller is reduced gradually, its cells shall be replaced.

1. Central locking control and antitheft alarm

www.CarGeek.ir



- When the key is pulled out of the ignition switch and four doors and two hoods all are closed, press the locking key of the remote controller once, all doors will be locked and all turn signal lights will flash once.
- When the key is pulled out of the ignition switch and four doors and the luggage carrier hood all are closed, press the locking key of the remote controller once, all doors will be locked and no turn signal light will flash. After the engine hood cover is closed, the turn signal lights will flash once.
- When the key is pulled out of the ignition switch and any of four doors or the luggage carrier hood is opened, press the locking key of the remote controller, the system will not act. Press the unlocking key of the remote controller once, only the front left door is unlocked and the turn signal lights flash twice. Press the unlocking key of the remote controller twice or more times, in the first time, only the front left door is unlocked and in the second time, all other doors (including the luggage carrier lock) are unlocked.

1. Central locking control and antitheft alarm 中国一汽

Password learning function of B50 remote control key

- Notice: when the key is inserted for the fifth time, it shall be kept in the ignition key hole. At this time, press any key of the remote controller once.
- After BCM is replaced, the execution conditions of the remote controller must be matched again. This function will be executed when the system is in the security release status. Within 7s after the door is opened, insert the key into the ignition switch and pull it out. Execute this action for four times. When the key is inserted for the fifth time, the horn will sound once and the interior lights turn off. At this time, press any button of the remote controller, the horn will sound once again and the interior lights turn on and then off. The learning of the remote controller is accomplished. Each car is equipped with only one remote controller.

1.5 Central locking switch

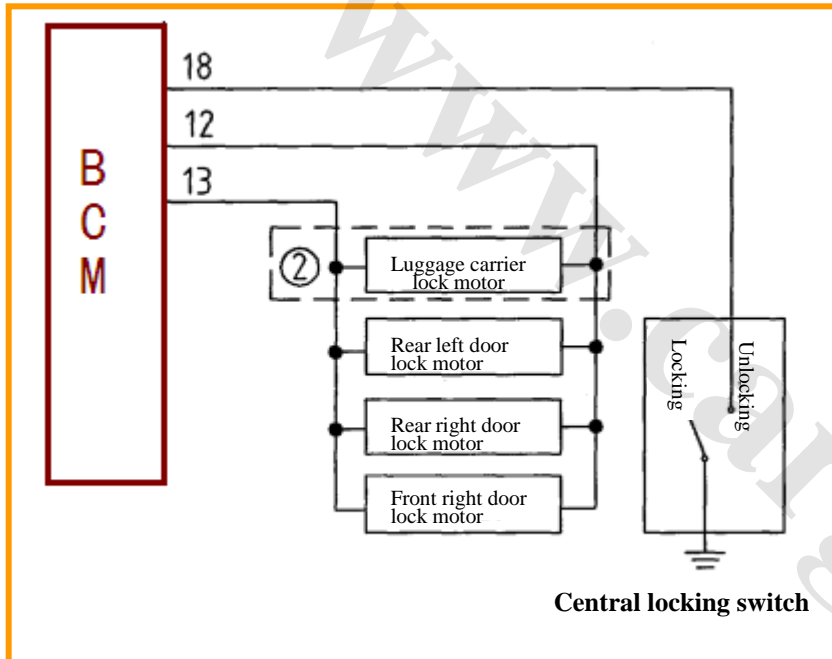

- Non-self-locking type switch
- This switch signal is connected in parallel to the driver door lock switch.



1.6 Locking assembly at the driver side

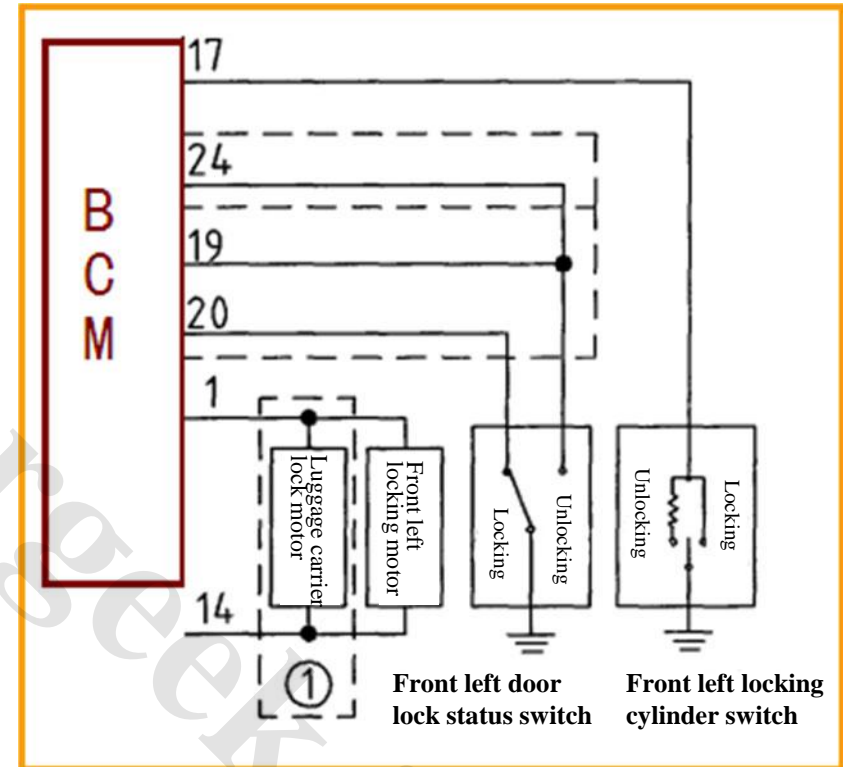
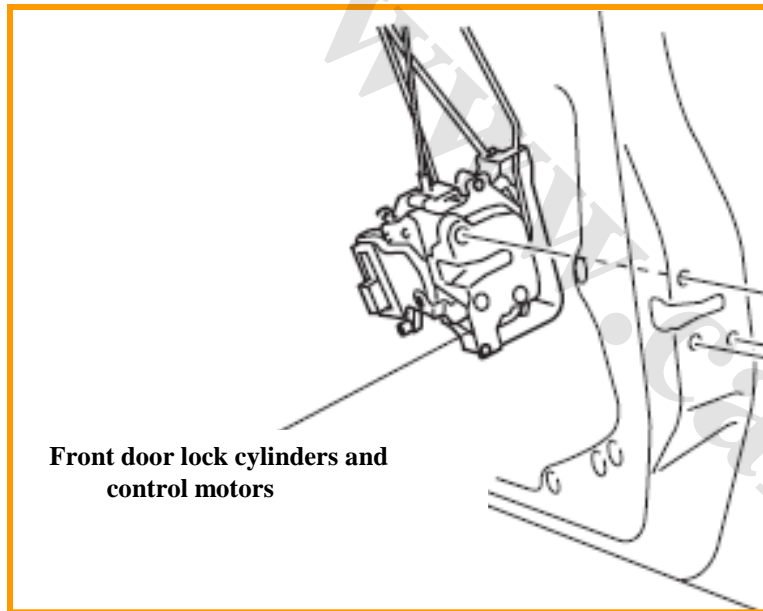

- Located in the front left door body.
- There are three electronic components.

Inspection of the front door lock motor

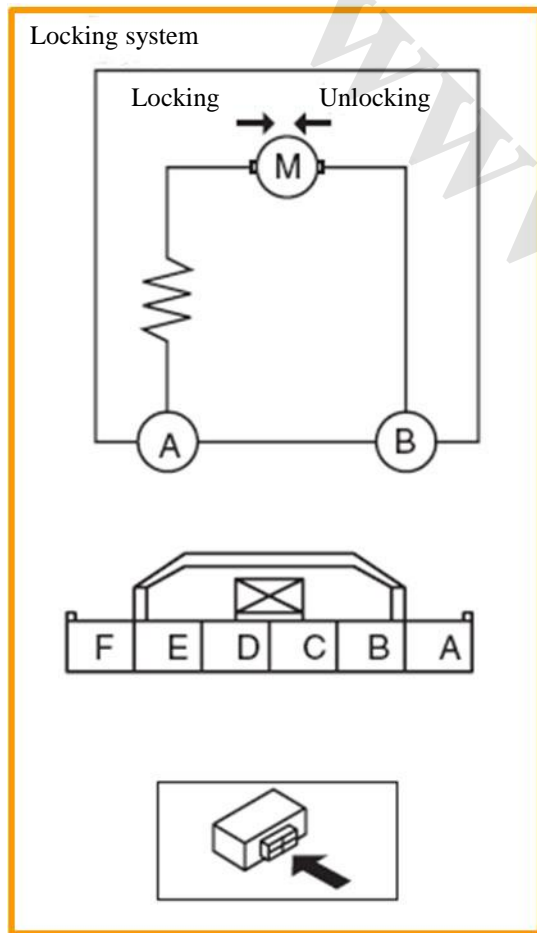

Locking control motor

- Disconnect the wiring trough of the front door lock control motor.
- Put the positive voltage of the accumulator battery to the terminal of the front door lock control motor and inspect its operation.
 - If it does not comply with the specification, please replace the front door lock control motor.

Locking system

Working principle of the actuator	Connection	
	B+	GND
Locking	A	B
Unlocking	B	A

1.7 Other locking assembly

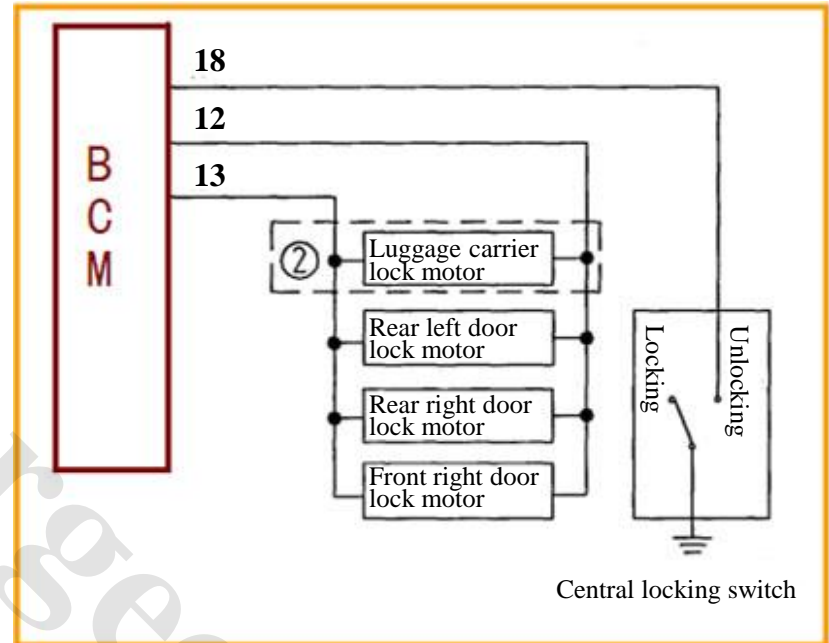
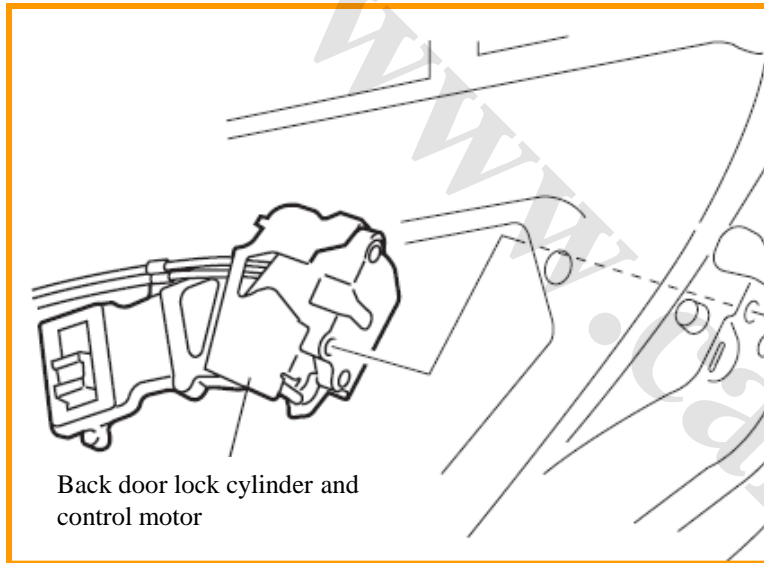

- Located in the corresponding door body.
- There are two electronic components.

1.8 Luggage carrier lock

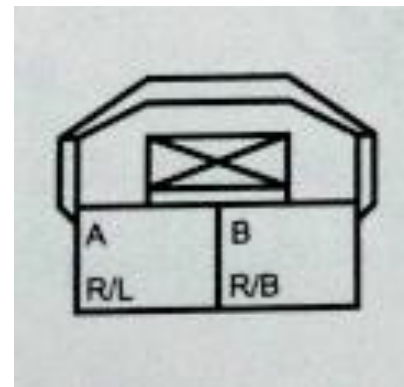
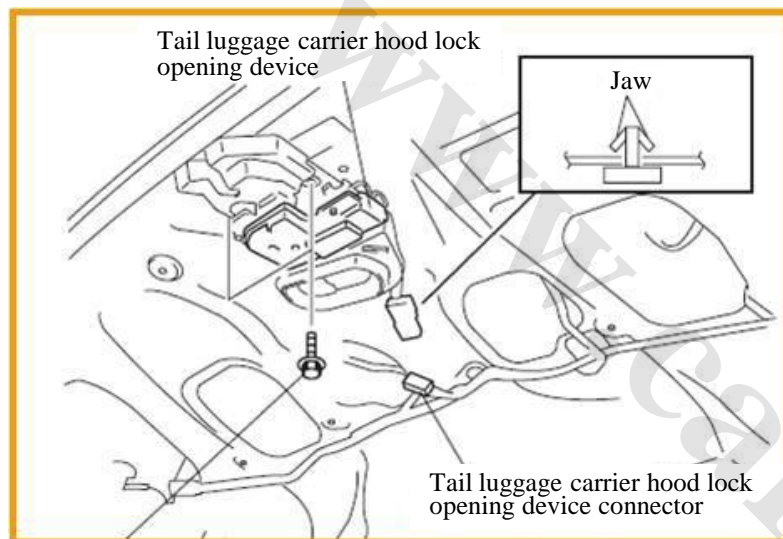

- Consisting of one luggage carrier lock motor.
- The luggage carrier lock and the central locking can be opened or closed simultaneously.

1. Central locking control and antitheft alarm

www.CarGeek.ir



1.9 Horn

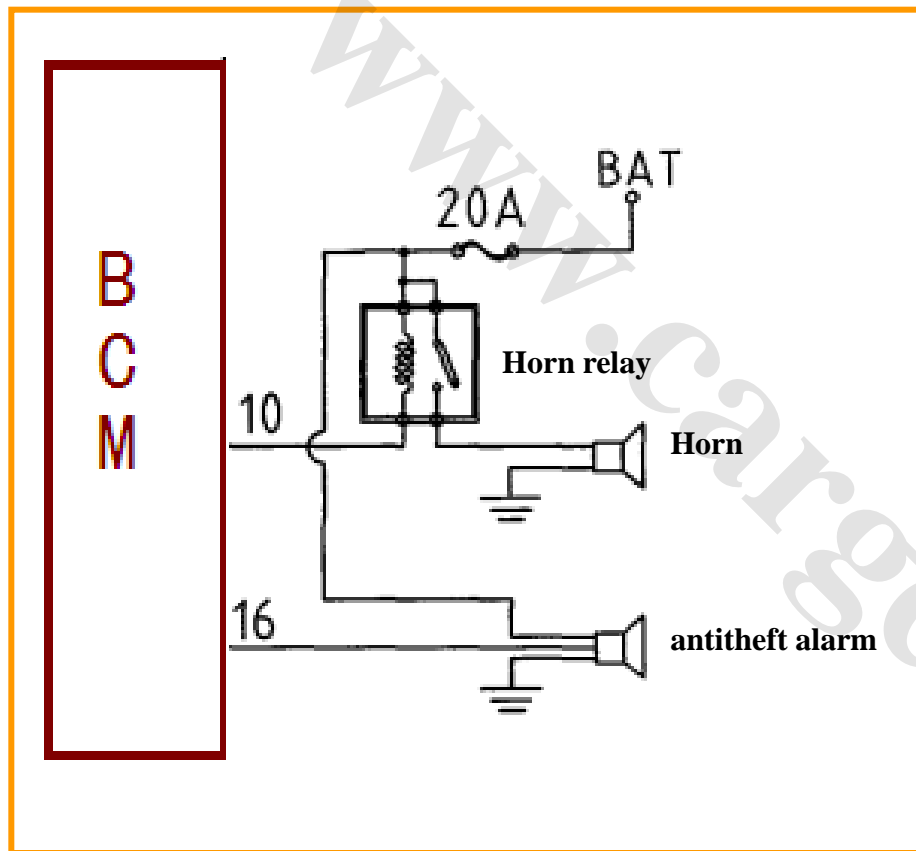

- BCM 10 pin is connected to earth of the horn relay coil.
- BCM 16 pin controls the work of the antitheft horn.

1.10 Status warning actions of the body antitheft system

➤ **antitheft alarming function**

- When the system is in the antitheft no-alarming status, opening the door interlock switch, the door touch switch and the luggage carrier switch or inserting the key in the ignition lock by force can make the system enter the antitheft alarming status. While alarming, left and right steering lights will flash (the frequency depending on the flashing relay) and the horn will sound (frequency of 2 ± 1 Hz). The alarm will stop after maintaining for 25-30s. If any other detection point is triggered, the system will repeat alarming.

Pressing any key of the remote controller once during alarming will stop the alarm. But the system is still in the antitheft no-alarming status.

After pressing the unlocking key of the remote controller for the second time, the system will enter the status of waiting to exit antitheft.

After pressing the unlocking key of the remote controller for the second time, the system will enter the antitheft no-alarming status.

Unlocking with the key (front left door or luggage carrier lock cylinder switch) or turning the key in the ignition lock to ACC shift during alarming will stop the alarm and the system will enter the normal status.

Locking with the key (front left door or luggage carrier lock cylinder switch) during alarming will stop the alarm and the system will enter the antitheft no-alarming status.

In the antitheft alarming status, if power supply of the accumulator battery is disconnected, the system will re-alarm for 25-30s after the power supply is re-connected.

➤ **Secondary antitheft**

- Execution condition: the key is not in the ignition lock, doors and the luggage carrier are closed, and the system is in the security no-alarming status or the waiting to exit antitheft status.
- Execution function: after pressing the remote control unlocking key, the system will enter the waiting to exit antitheft status. If the doors or the luggage carrier are not opened or the key is not inserted in the ignition lock within 20s, the system will enter the antitheft no-alarming status after 20s. Otherwise, it will enter the normal status.

2. Electric window lifting control

www.CarGeek.ir



2.1 Component position

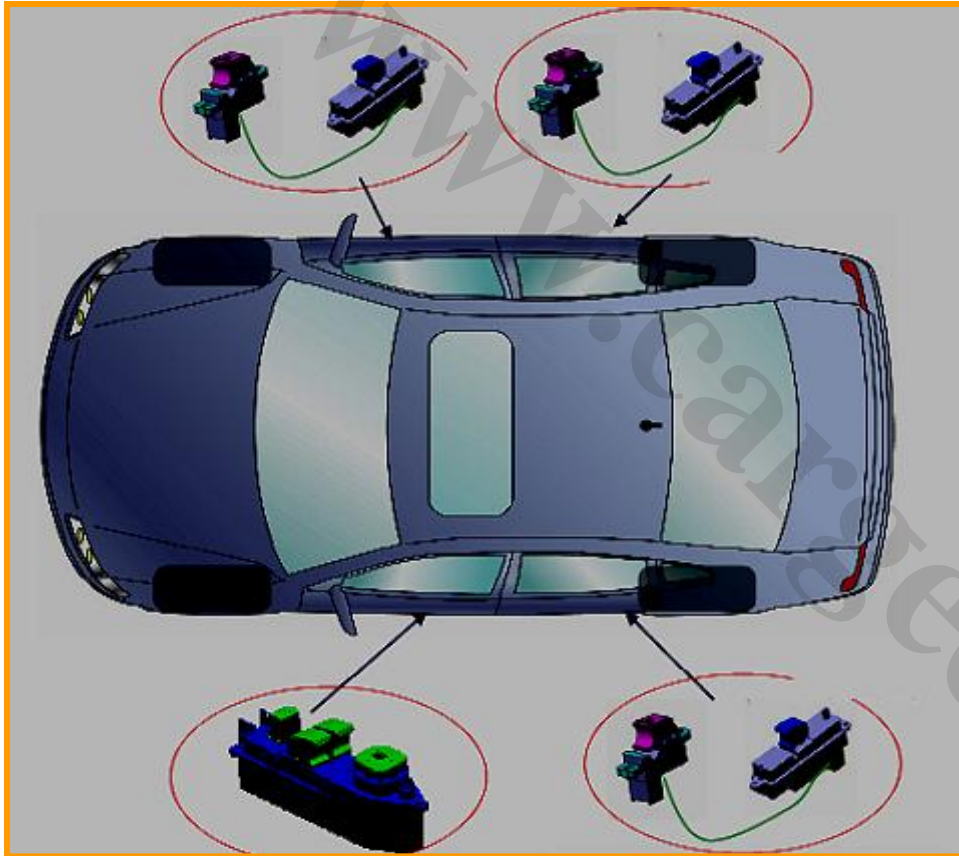

2.2 Control of the windows

➤ Manual and automatic modes of the glass lifting control

Manual: when pressing the glass lifting switch for more than 300 millisecond (long pressing), it is the manual glass lifting control.

Automatic : when pressing the glass lifting switch for more than 50 millisecond but less than 300 millisecond, it is the automatic glass lifting control. If pressing the glass lifting switch for less than 50ms, the glass lifting motor does not act.

➤ When any of the following conditions occurs, the glass lifting motor will stop:

- When the glass lifting switch is pressed again during the automatic lifting.
- When the glass is lifted to top or dropped to bottom.
- After turning to the OFF shift or ACC shift, within $120s \pm 10%$: when the glass is lifted or descended to the limit in automatic mode; in the manual mode, when the time is up, the glass lifting will stop immediately.
- During the glass lifting, the glass stops the action at IGN-ST.

➤ Anti-clighting management

The anti-clighting protection exists both in the automatic and manual modes. If the anti-clighting system fails, automatic descending of the glass is permissible within two minutes after turning to the ON and OFF shifts or the ACC shift; at the ON shift, the automatic lifting of the front left door glass is permissible ,lifting of other door glass isn't permissible in any case.

➤ Control without the anti-clighting function

- If the anti-clighting system fails or there is no anti-clighting function, automatic descending of the glass is permissible within two minutes after turning to the ON and OFF shifts or the ACC shift; except the front left door, the glass of other three doors has no function of automatic lifting.
- At the ON shift, automatic glass lifting of the front left door is permissible and the glass of other doors has no function of automatic lifting. And in this power supply mode, whether the door is open or not, it does not affect the normal lifting of the glass.
- If four doors are closed within two minutes after turning to the OFF shift or ACC, their glass can be lifted normally.
- If any one door is open within two minutes after turning to the OFF shift or ACC, the glass of four doors can not be lifted.

➤ Glass inhibit function

- At the ON shift, press down the glass inhibit switch, the local glass lifting function of the passenger door and rear doors is prohibited. But at the driver side, its glass lifting can still be controlled.
- When the glass inhibit switch is pressed down, the indicator light of the glass inhibit switch is on and backlight of the glass lifting switch of the passenger door and rear doors is off.
- If the glass inhibit switch is pressed down rightly when the glass of rear doors and the passenger door is lifting or descending, their lifting can be stopped and backlight of the glass lifting switch turns off simultaneously. If the glass inhibit switch has already been pressed down (the glass lifting of rear doors and the passenger door is in the inhibit status) after KEY-OFF or ACC, the indicator light of the glass inhibit switch will be turned on for two minutes. If the glass inhibit switch is not pressed down, it can be pressed down within two minutes to inhibit the glass lifting of rear doors and the passenger door.

2.3 Electric window manual (automatic) signal control flow

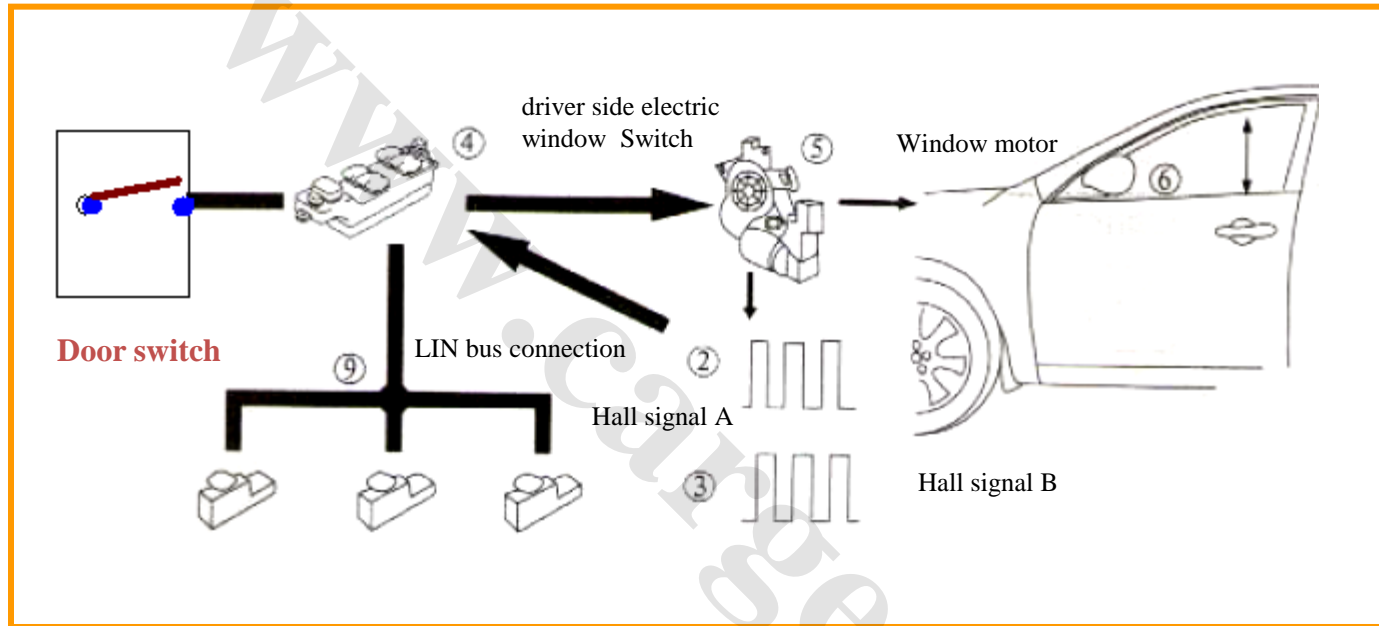

Electric window lifting motor	With two hall sensors, a pair of hall impulse signals can be transmitted
Electric window switch at the driver side	To receive the remote control signals and transmit them to the switch control module
LIN	Information transmission between BCM and the switch control module

Block diagram of CAN connection of the glass lifting system

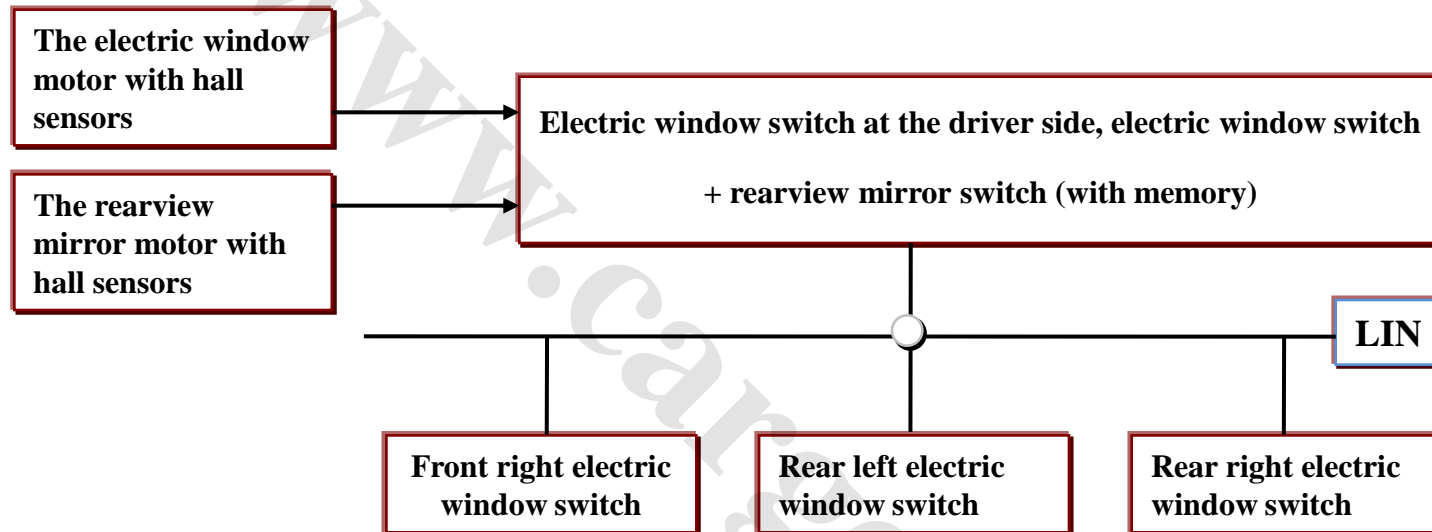

Window lifting adjustment:

- The electric window switch at the driver side can directly control the window glass at this side. At the same time, the electric window switch at the driver side is connected to those switches at other sides via LIN bus, consequently control the window glass at other sides.

Electric window manual (automatic) opening/closing function

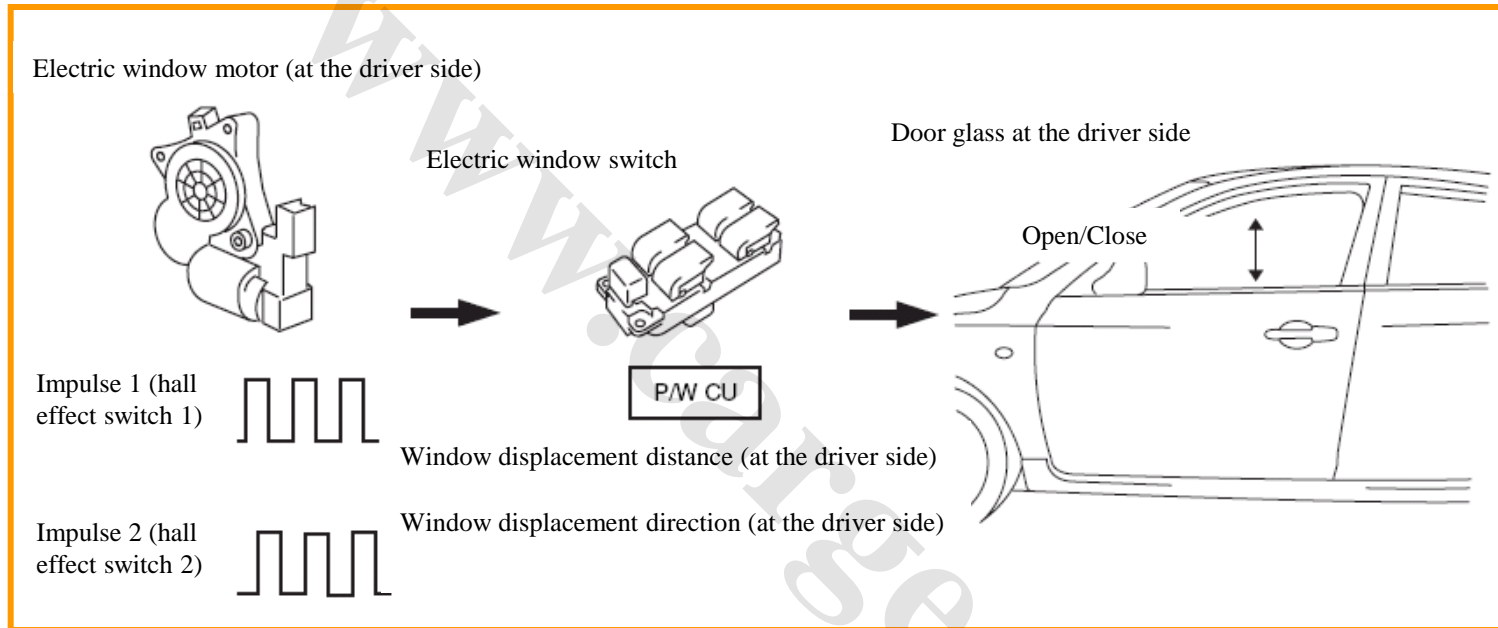

Notice: it is required to reset the automatic lifting function in the following conditions:

- To disconnect the negative cable of the accumulator battery.
- To dismantle the power fuse of the electric window system.
- To disconnect the connector of the electric window switch.

2.4 Front left door glass lifter combination switch

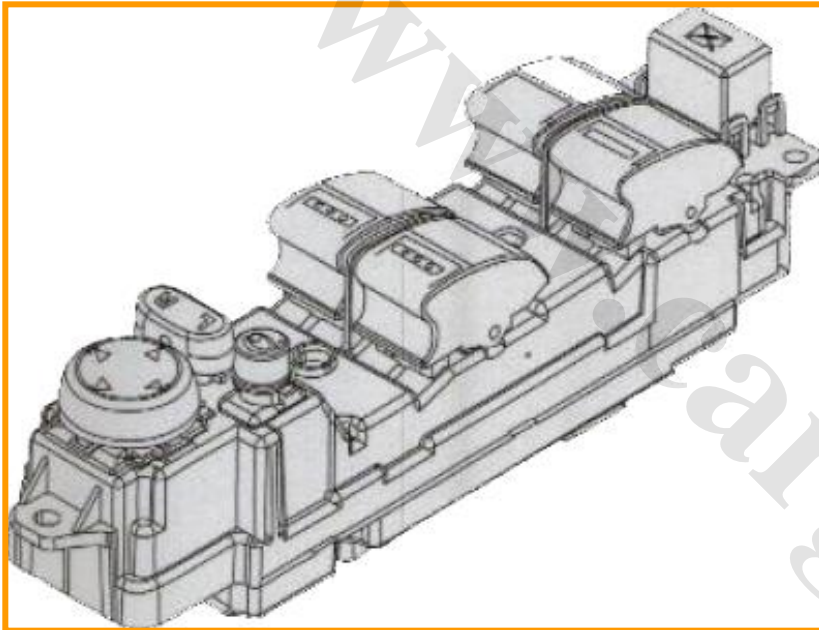

- Including glass lifter switches of front left door, front right door, rear left door and rear right door and safety switch of the rear windows.
- The safety switch is a self-locking one. After it is pressed down, the operation function of the glass lifter switches in front right door, rear left door and rear right door is prohibited.

2. Electric window lifting control

- Manual mode: pressing time ≥ 300 ms
- Automatic descending mode: pressing time < 300 ms
- Delay function: the glass lifting switch can be operated within 120 second after the ignition key is pulled out.
- Stop detection: automatic detection of upper and lower dead centers and control of the motor stop.
- Operation conflict: when front left door controls the glass of one door to lift or descend while the switch of the latter door control the glass to descend or lift, the descending will prevail.
- Anti-clamping function: the anti-clamping function of front left door and front right door is optional and anti-clamping can be achieved by detecting the motor current.
- Control the window lifting with the remote control key: if the door glass does not lift when the remote controller is used to lock the door after all doors are closed, pressing down the locking key of the remote controller for more than 2s can not only lock the doors but lift the door glass.

2.5 Structure of the electric window motor

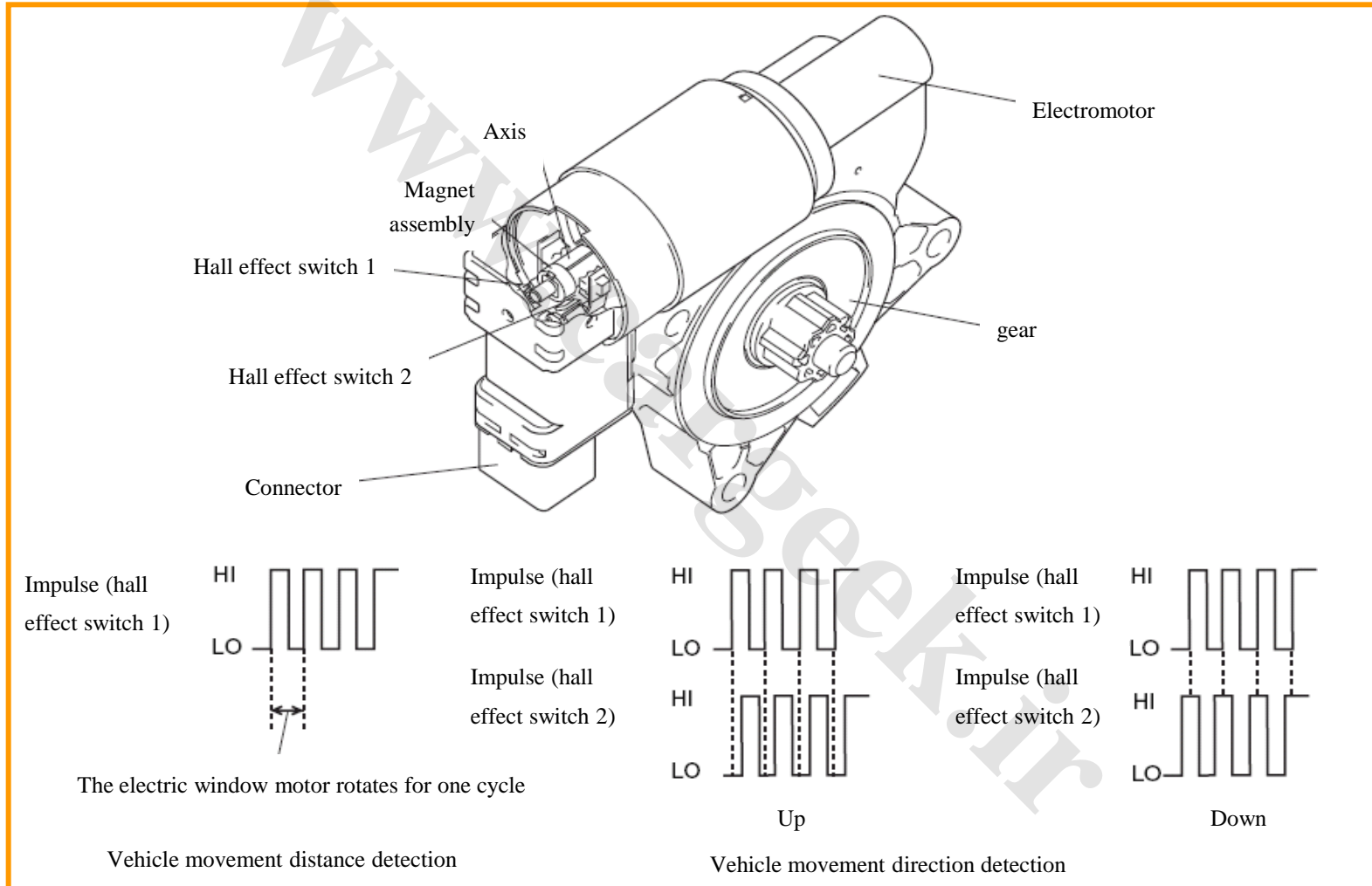

2.6 Circuit diagram of B50 electric glass window lifting

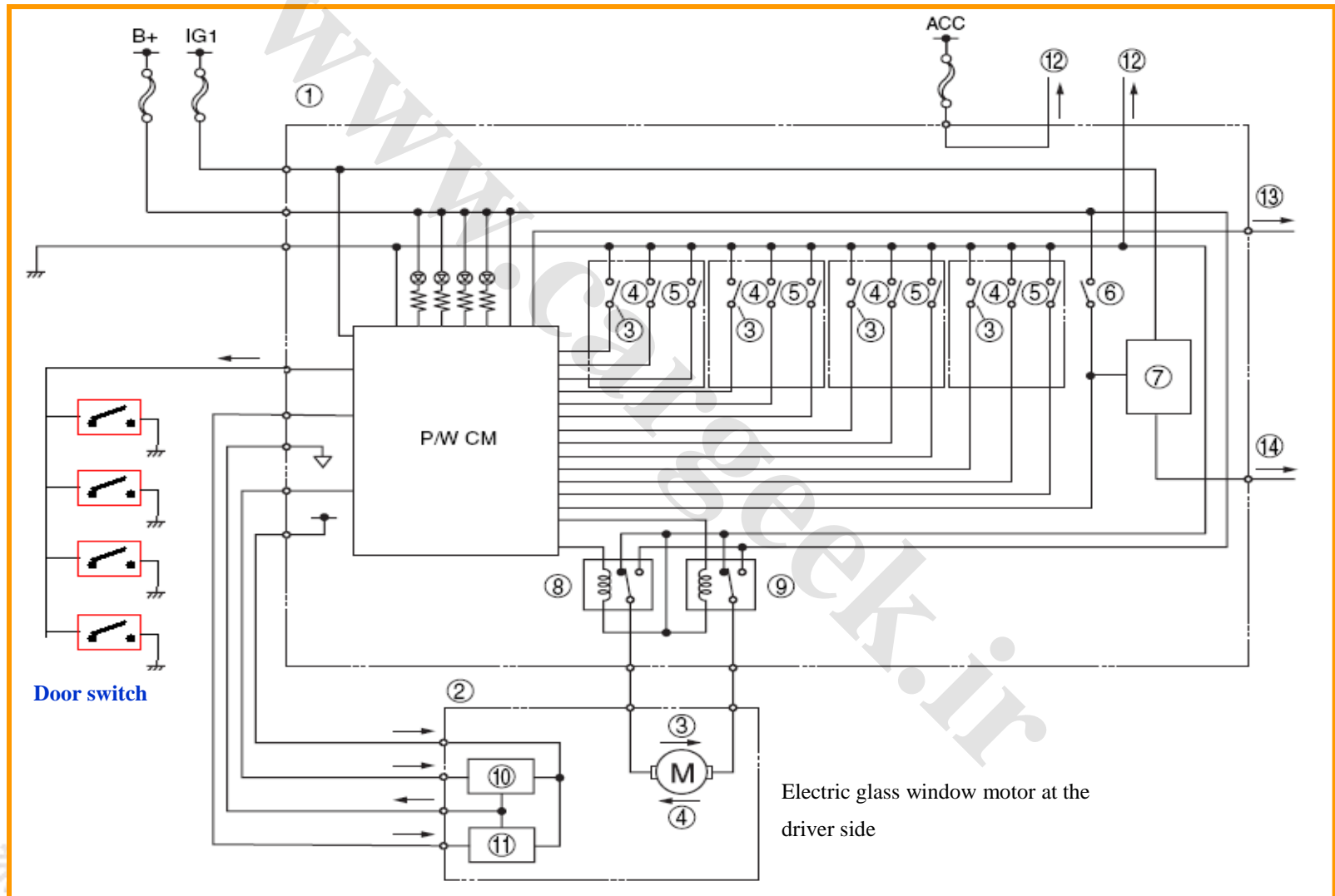

3.1 Functions and composition of the sunroof



➤ Function

- To exhaust dirty air in the interior by using the negative pressure of the roof during the driving
- To rapidly reduce the interior temperature and defog the interior
- To improve the internal light and environment etc.

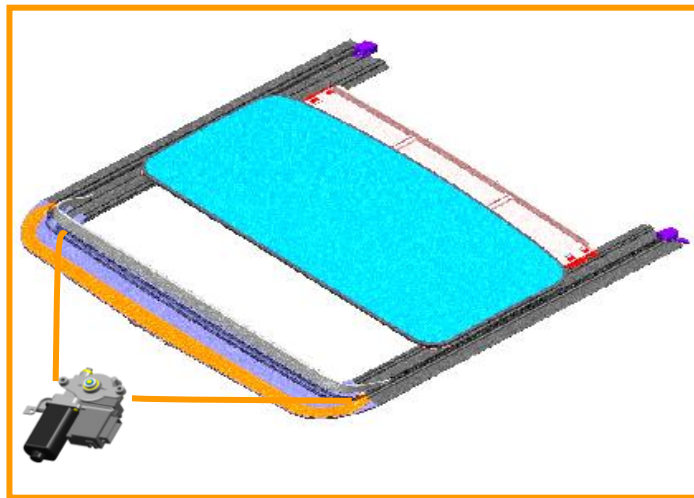

➤ composition

- Sunroof switch
- Sunroof motor (module)
- Sunroof assembly (including sunroof glass, sun visor, deflector, sealing strip, sliding mechanism etc.)

Gliding sunroof

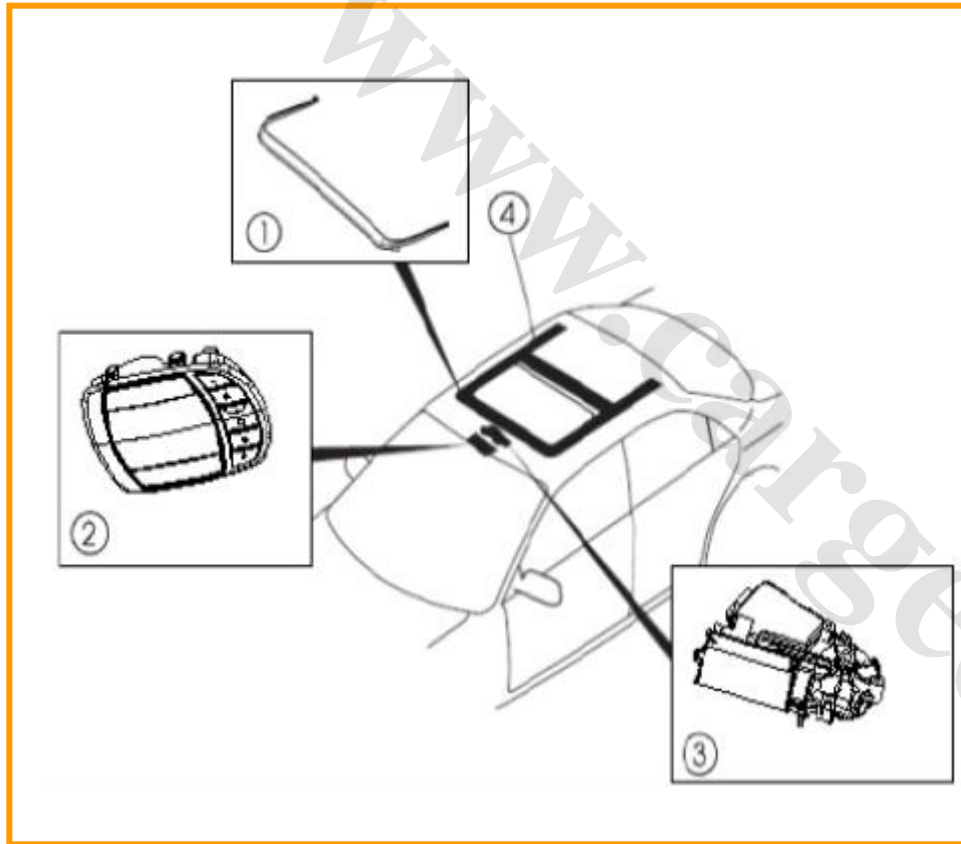

1 Weather strip

2 Top sunroof switch

3 Top sunroof motor

4 Top sunroof device

- The glass panel can be opened / closed via inclining and sliding operations.
- When the ignition switch is ON, the sunroof can be operated via the sunroof switch.
- If the ignition switch is turned to LOCK or ACC positions when the sunroof works, the sunroof will be stopped.
- The single-touch operation of the sliding open or inclining upward switch can achieve the automatic operation
- If any switch acts during the automatic operation, the sunroof will stop.
- If any failure is detected during the operation of the sunroof, the failure protection will act to ensure safety.

3. Sunroof system

Functions of manual opening, manual closing, automatic opening, automatic closing, manual inclining opening and automatic inclining opening



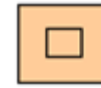

The sunroof switch has two keys:

Tilting opening and built-in closing is realized by one key SLIDE



Tilting closing and built-in opening is realized by one key TILT



Sunroof action status	Switch operation modes
Manual/inching tilting opening	 SLIDE long-press keeping/inching operation
Manual tilting closing	 TILT long-press keeping (no inching function)
Manual/inching built-in opening	 Manual/inching built-in closing
TILT long-press keeping/inching operation	 SLIDE long-press keeping/inching operation

Notice: It can be achieved only by executing inching function of the initialized sunroof. Otherwise, the sunroof can only be opened or closed manually.

Remote control window closing function

- When the sunroof is opened initially (built-in opening and tilting opening), the remote window closing operation can be done by the locking key of the remote controller.
- Operation method: long press the locking key of the remote controller. When the pressing time exceeds 1.5s, the sunroof begins to move to the closing position. It keeps on moving to the closing position during the long press of the locking key until reaches the closing position. If the key is released before the sunroof reaches the closing position, the sunroof will stop at the current position immediately.

- Valid conditions for remote window closing include:

- a) The key is pull out of the ignition lock;
- b) Four doors and the luggage carrier hood of the car are closed;
- c) The initialization of the sunroof control unit is completed;

The achievement of remote operation is controlled via BCM. BCM judges whether the remote operation conditions are met firstly. BCM will send the closing instruction to the sunroof control unit via LIN bus and the latter will respond to this instruction and perform the closing operation.

Sunroof initialization

- Operate the sunroof to the maximum position of soft tilting opening in the manual or inching mode.
- Long press the tilting opening button of the sunroof (SLIDE). When the pressing time exceeds 7s, the sunroof will move from the maximum position of soft tilting to that of hard tilting until the motor stops. At this time, the sunroof assembly will vibrate.
- Release the sunroof tilting opening button (SLIDE). Within 5s, press down the sunroof tilting opening button (SLIDE) again. When the pressing time exceeds 1s, the sunroof will start to execute the following re-initialization flow: sunroof tilting closing→ sunroof built-in opening to maximum→ sunroof built-in closing. After the above flow, the sunroof will be in stationary state. The re-initialization of the sunroof control unit is completed successfully.

3.2 Block diagrams and circuit diagrams

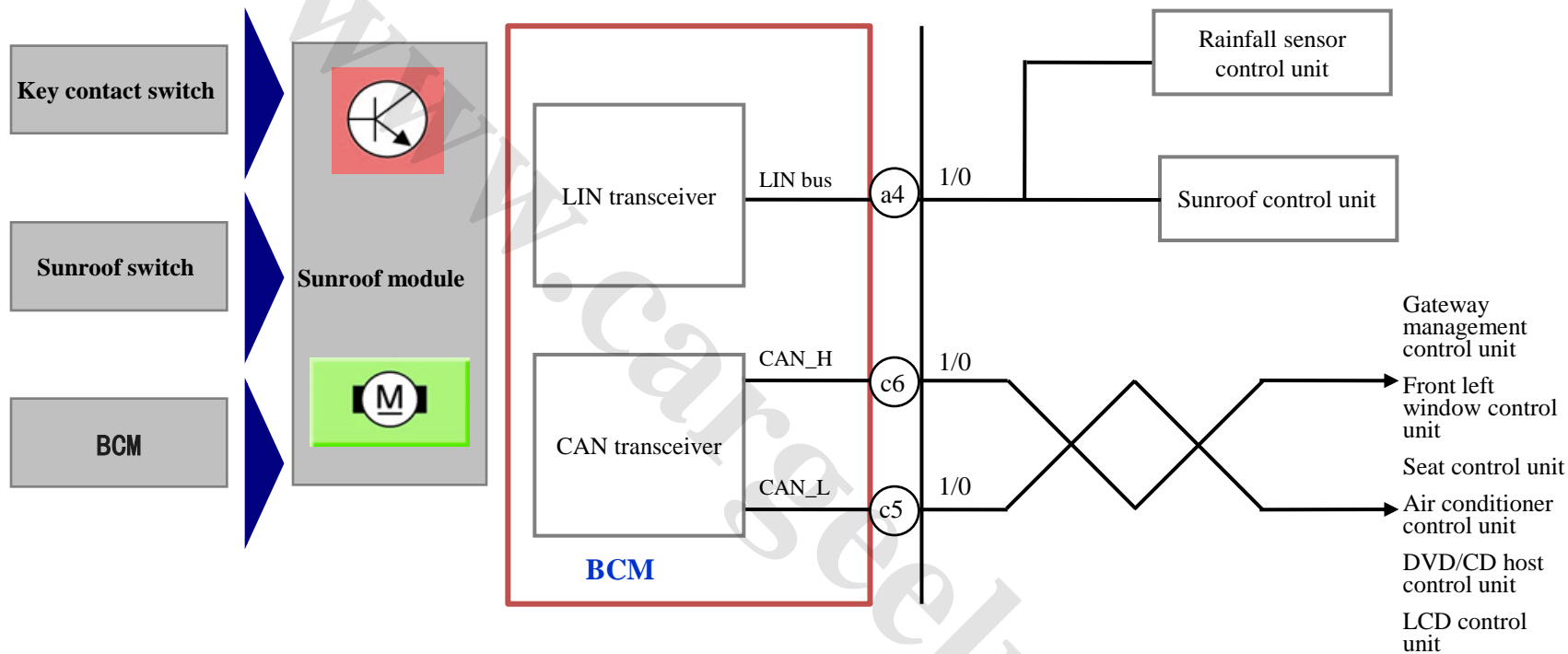

3. Sunroof system

3.3 B50 sunroof circuitry

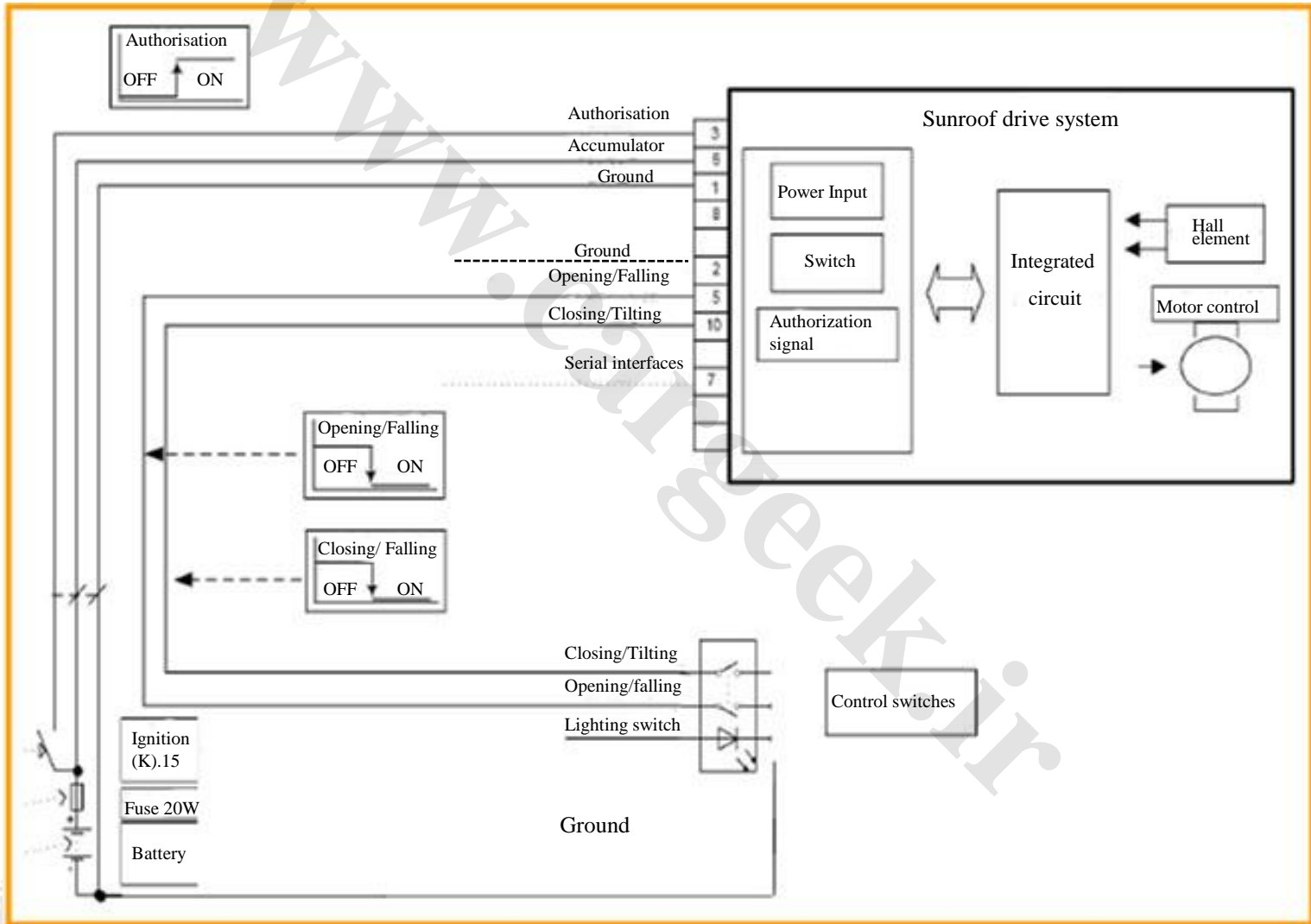

3.4 Functions of the sunroof system and failure protection

Item	Technical specifications	Cancellation conditions
Continuous electrification monitoring function (switch card opening monitoring function)	If the switch is opened for a time longer than the set time (60s), the operation will stop.	The switch is closed and then opened.
Continuous operation monitoring function	If the accumulated electrification time due to continuous opening/closing is longer than the set time (120s), the operation will stop (If the close time reaches the set time, the sunroof will return to the fully opening position.)	20s after the operation stops
Relay monitoring function	If the motor power supply is opened continuously because of seizure of breaker point of the relay at one side or similar failure, another relay will be opened to cut off the electrification of the motor. (The prompt ignition switch has been turned to the LOCK or ACC position, the coil still is electrified.)	The relay is not seized any more
Clamping detection function	If the impulse change of hall effect switch 1 does not exceed the set time (400ms), the operation will stop (the clamping condition is detected).	After the clamping condition is solved, the switch is closed and then opened.
Static load detection function	If the clamping condition is detected while the glass panel is sliding, the activity operation will stop. Load setting: 343N {35kgf, 77lbf} or higher	After the clamping condition is solved, the switch is closed and then opened.
Hall effect switch failure	If abnormal hall effect switch impulse is detected, the system will enter the safety mode. <ul style="list-style-type: none"> Abnormality operation occurs: the operation will stop Abnormal conditions during the switching operation: the glass panel will operate in the operation direction of the sunroof switch for 400ms and then stop. 	Normal impulse of the hall effect switch is detected. (It can be fully recovered to normal only after the setting of initial position is completed.)

4.1 System composition

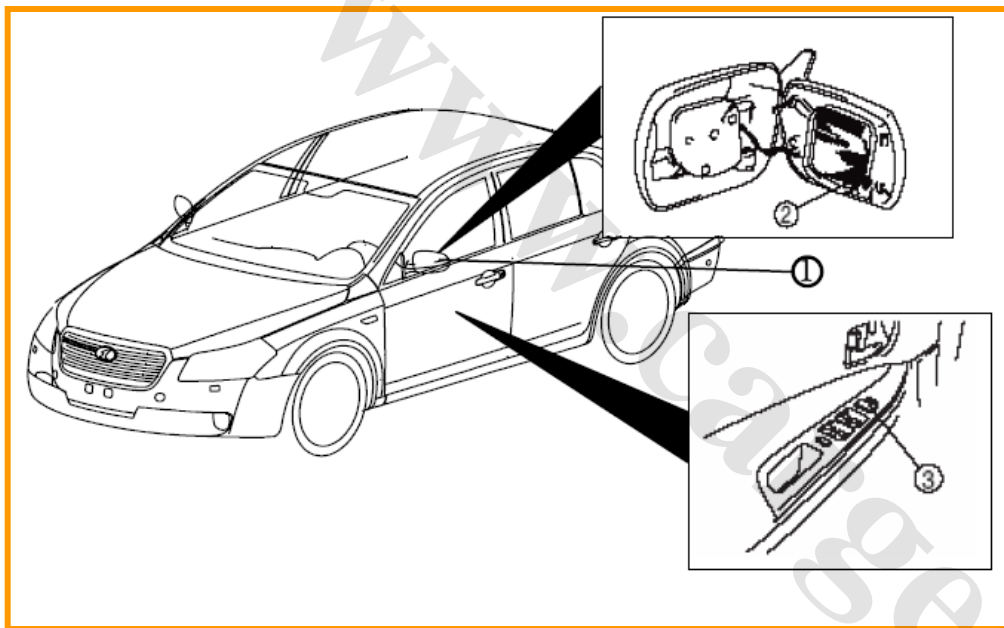

The electric rearview mirror system is composed of the following elements:

- Left and right rearview mirror assemblies (including two regulation motors and anti-lightning hall sensors)
- Electric heating lens
- Rearview mirror selection switch
- Direction adjustment switch
- Front BCM control module
- Air conditioner control module

4. Electric rearview mirror

4.2 Control circuit diagram of B50 system

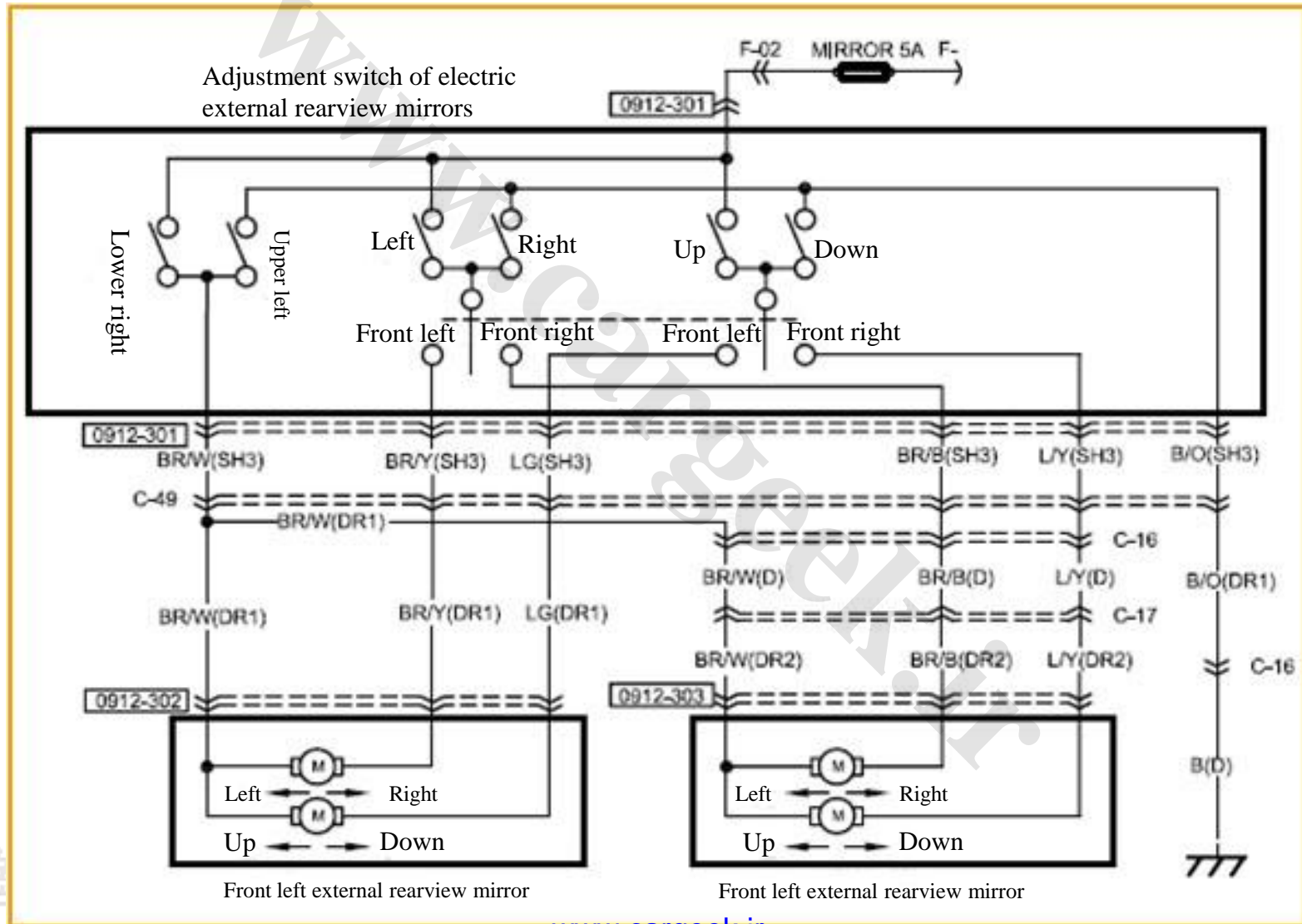

5.1 Structure of electrically adjustable seats

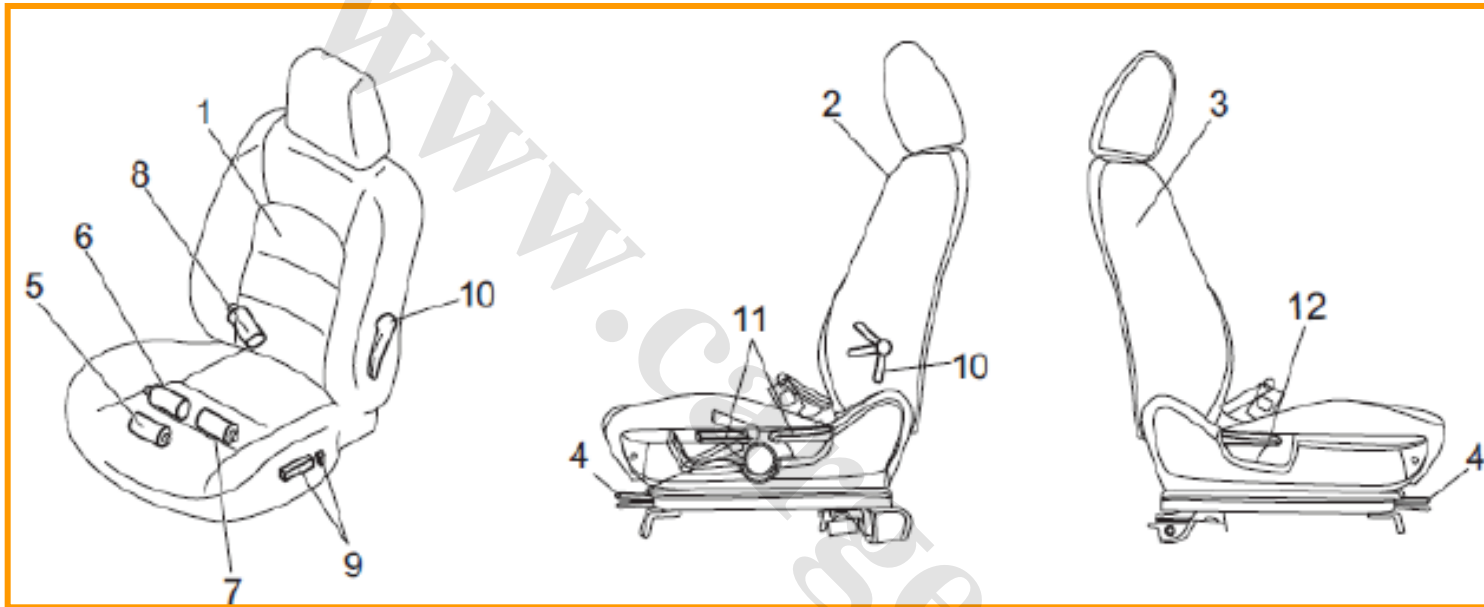

There are three types for front seats:

- Six-direction manually-adjustable seats (at the driver side)
- Eight-direction electrically-adjustable seats (at the driver side and at the side with airbag)
- Four-direction manually-adjustable seats (at the passenger side)
- The driver seat adopts the lumbar support.

5. Electric memory seat

5.2 B50 electric seats

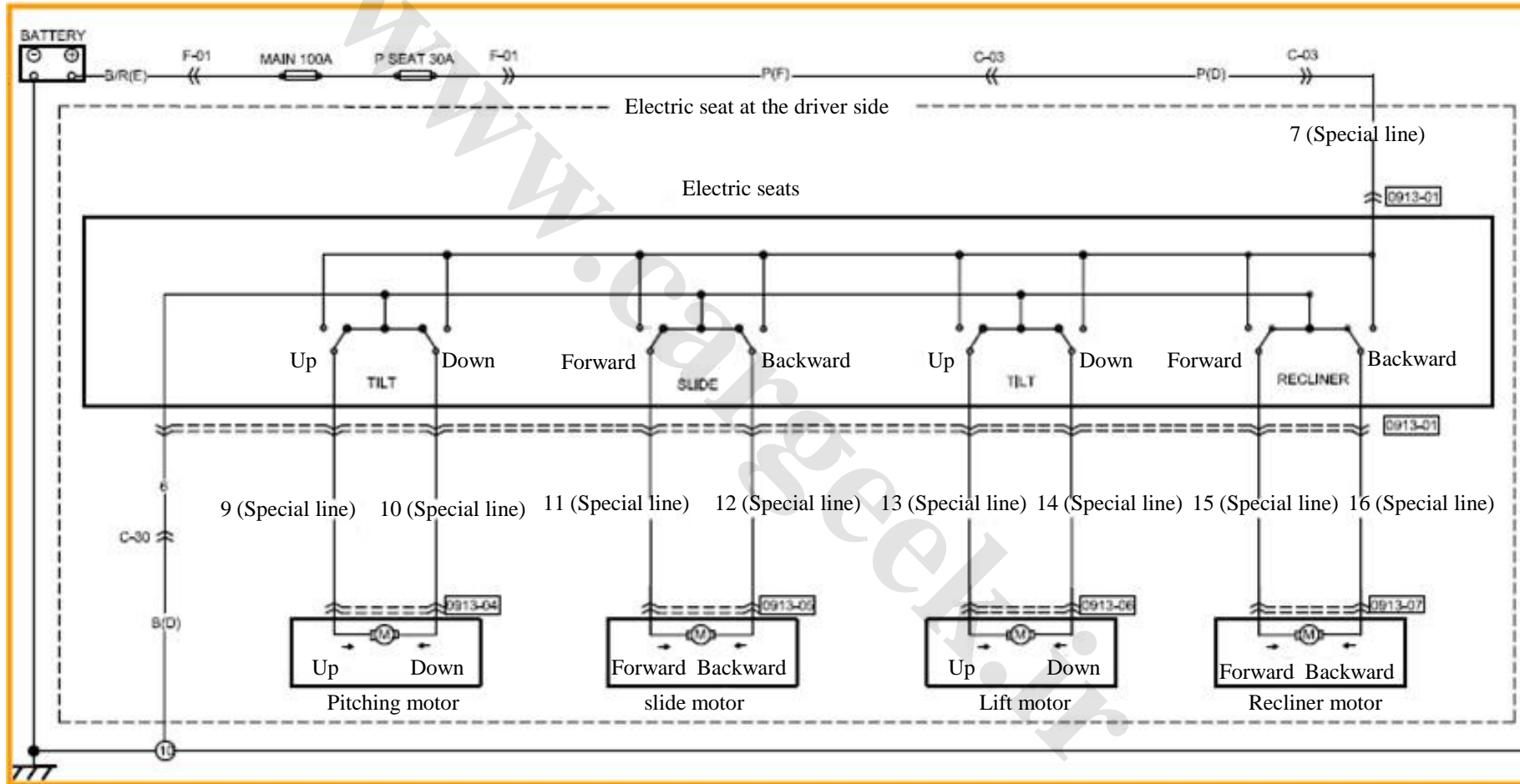

6.1 Work of internal lights



Internal lights

Working conditions of the internal lights (automatic mode)

Lightening function of internal lights

Execution condition: the internal light switch is put in the DOOR shift

Execution functions:

In the case that all the doors are closed, the internal lights will be lightened and go out after 10 minutes when any door is open and they will be lightened and go out after 10s (when the key is not in the ignition lock) or after 1s (when the key is in the ignition lock) when the door is closed.

In the case that all the doors are closed, the internal lights will be lightened and go out after 10s when the key is pulled out from the ignition lock. The internal lights will go out after 1s when the key is inserted in the ignition lock when they are on.

While unlocking with the remote controller or the key, the internal lights will be lightened and go out after 10s. Locking with the remote controller or the key during the period the internal lights are on will make them go out.



Ceiling handrail light

6.2 Control circuit diagram of B50 system

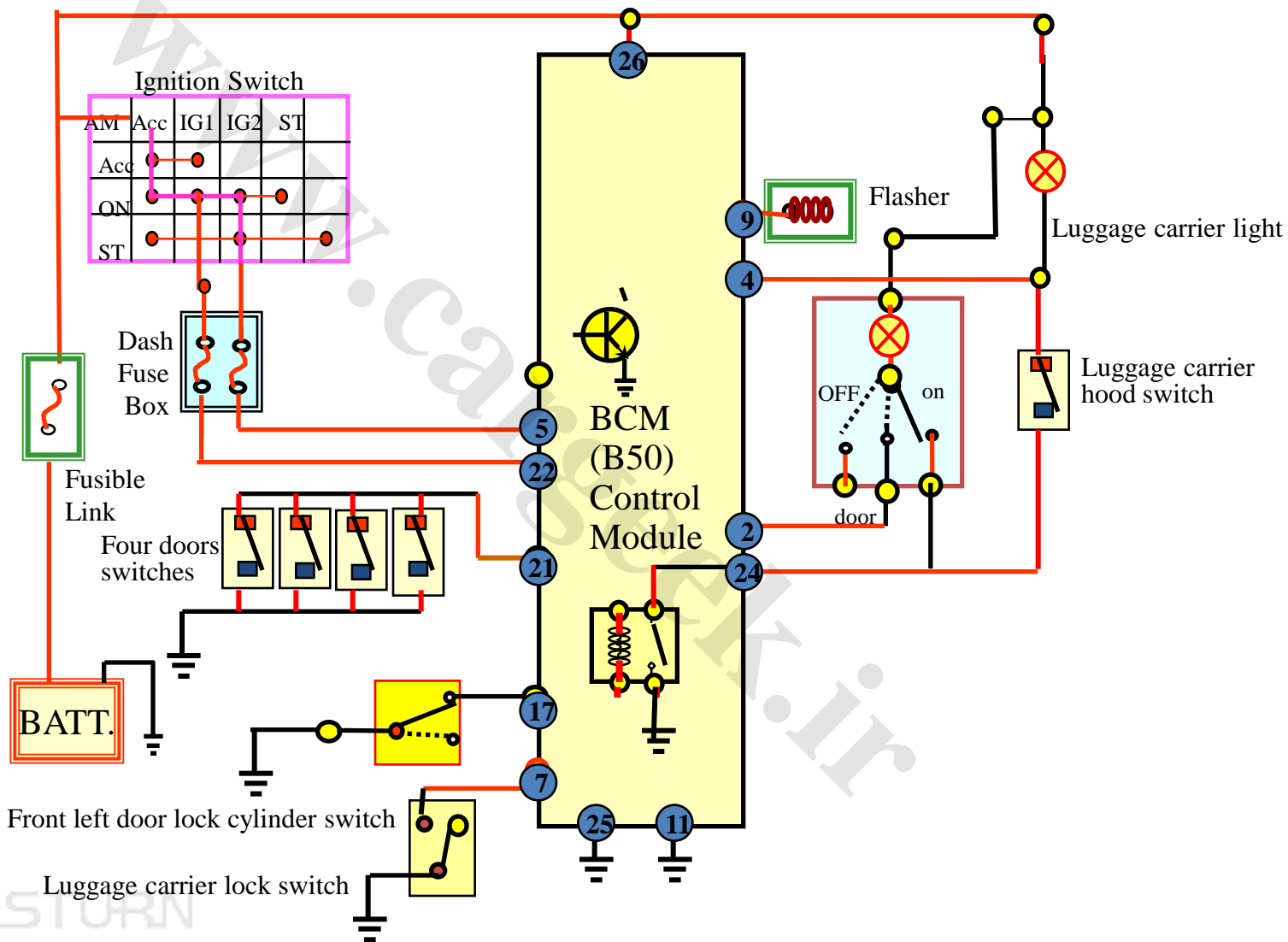

www.cargeek.ir
Thank you !

奔腾 BESTURN

Technical Training of BESTURN B50

— Car body electrical system (b)

奔腾 BESTURN

Suitable post: Technical chief

Curriculum Goals

- To understand basic information about the car body electrical system
- To master the reading method of the circuit diagram
- To know about the position, function and characteristics of various components of the body electrical system
- To master the methods to maintain and diagnose various components of the body electrical system

Contents



1. External lighting system

2. Windshield wiper System

3. Instrument Display System

4. Audio and Entertainment System

5. Reversing Radar System

1.1 BCM Function of B50 External Lighting System

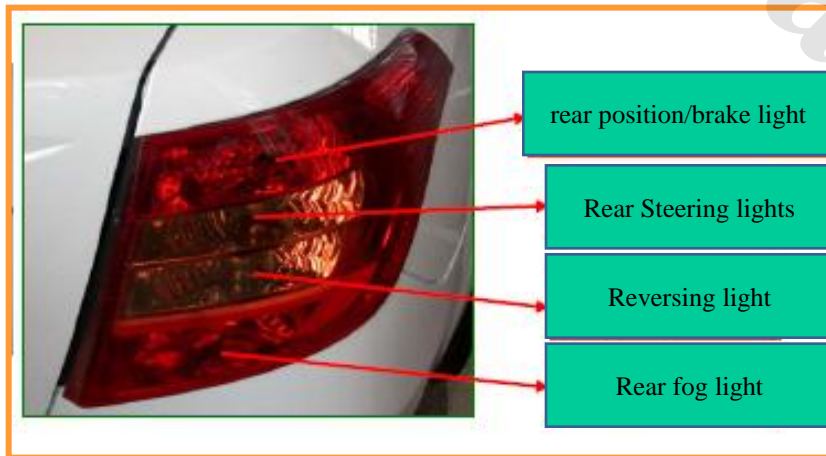

Lighting power saving function and headlight delay lighting function

Execution functions:

- In any of the following conditions, the lighting power saving relay is disconnected and the internal lights (Normal open shift) and front combination lights will be shut down by force.
 - 20s later when the system is put into the antitheft status with the remote controller (this time is the headlight delay time);
 - After 20s the car is locked via the front left door lock cylinder with the mechanical key (this time is the headlight delay time).
- In any of the following conditions, the lighting power saving relay is connected and the internal lights (Normal open shift) and front combination lights can return normal.
 - The front left door lock cylinder or the luggage carrier lock cylinder is opened or closed with the key or the lock is unlocked or locked with the remote controller;
 - The key tip switch status changes or the ignition switch shift changes.

1. External lighting system

1.2 Light control circuit diagram of B50 system

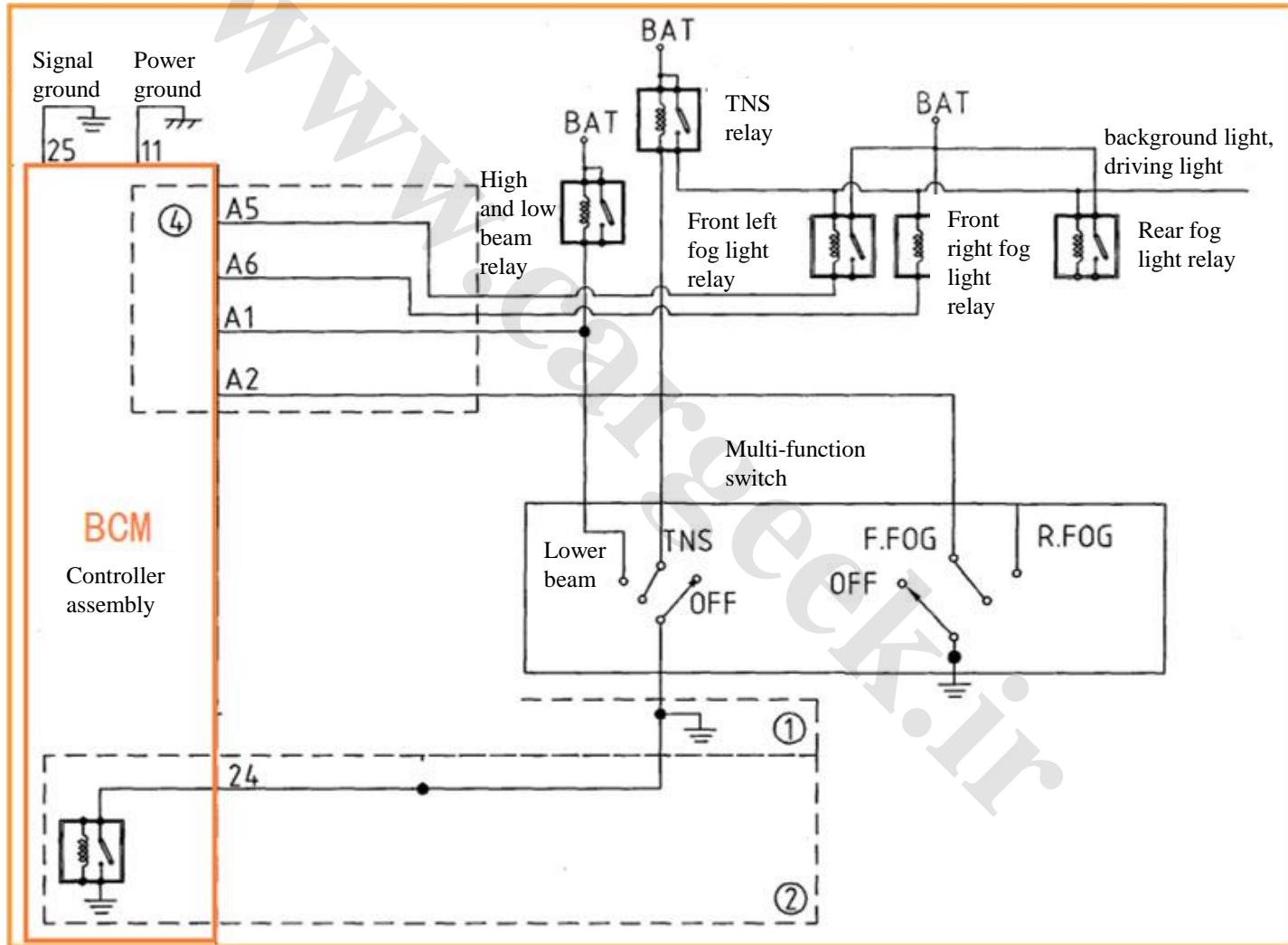

1. External lighting system

1.3 Assembly of Light Switch

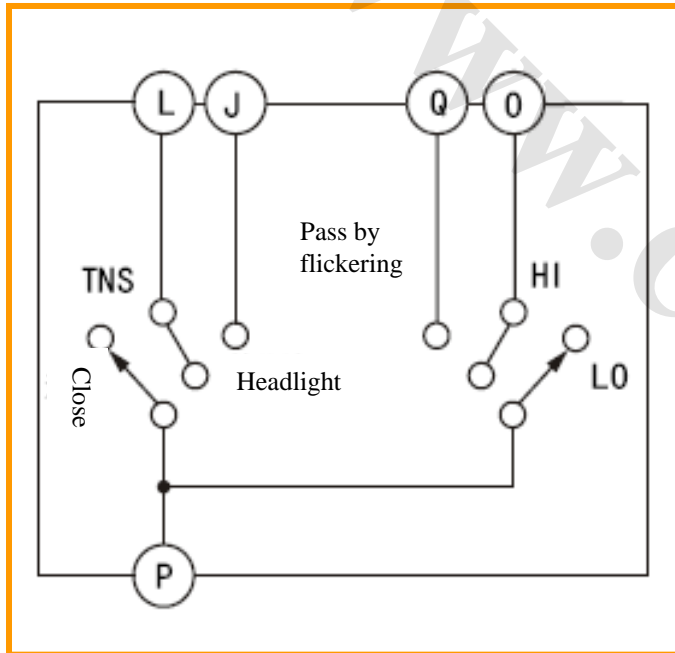

Switch Position			Terminals		
lighting lamp	Front fog light switch	Rear fog light switch	P	L	J
OFF	Close	—			
	Open	—			
TNS	Open	Close	○ — ○		
	Open	Open	○ — ○ — ○		
Headlight	Open	Close	○ — ○		
	Open	Open	○ — ○ — ○		

1.4 Regulation of headlight

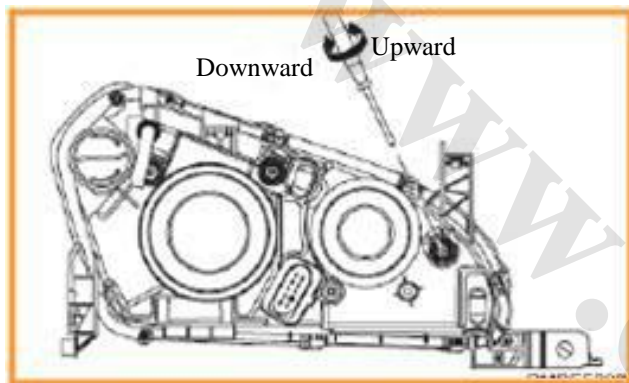

Lower beam

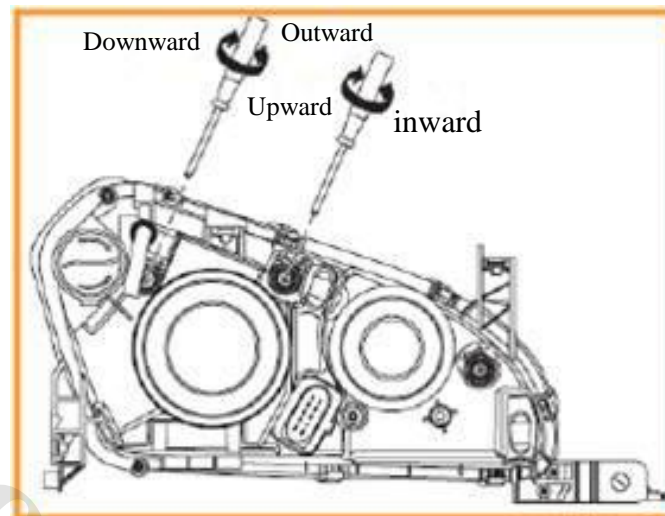

High beam

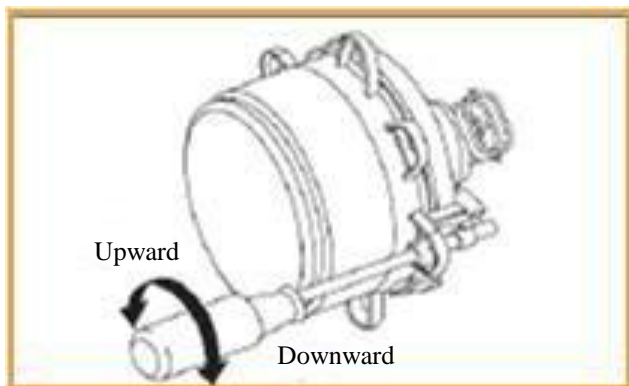

Fog light

1. External lighting system

1.5 Control of front/rear fog light

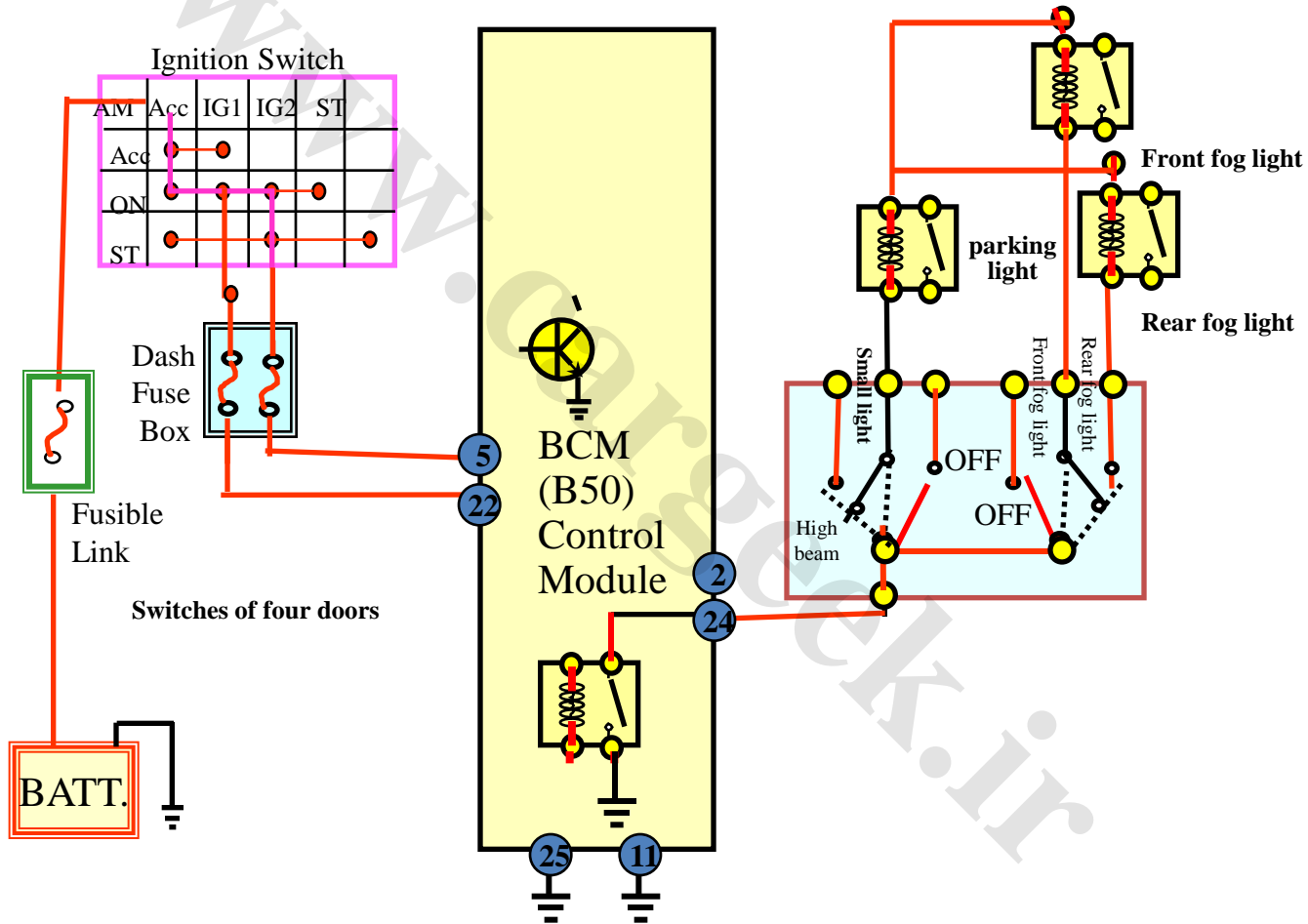

1.6 Turn light and hazard light

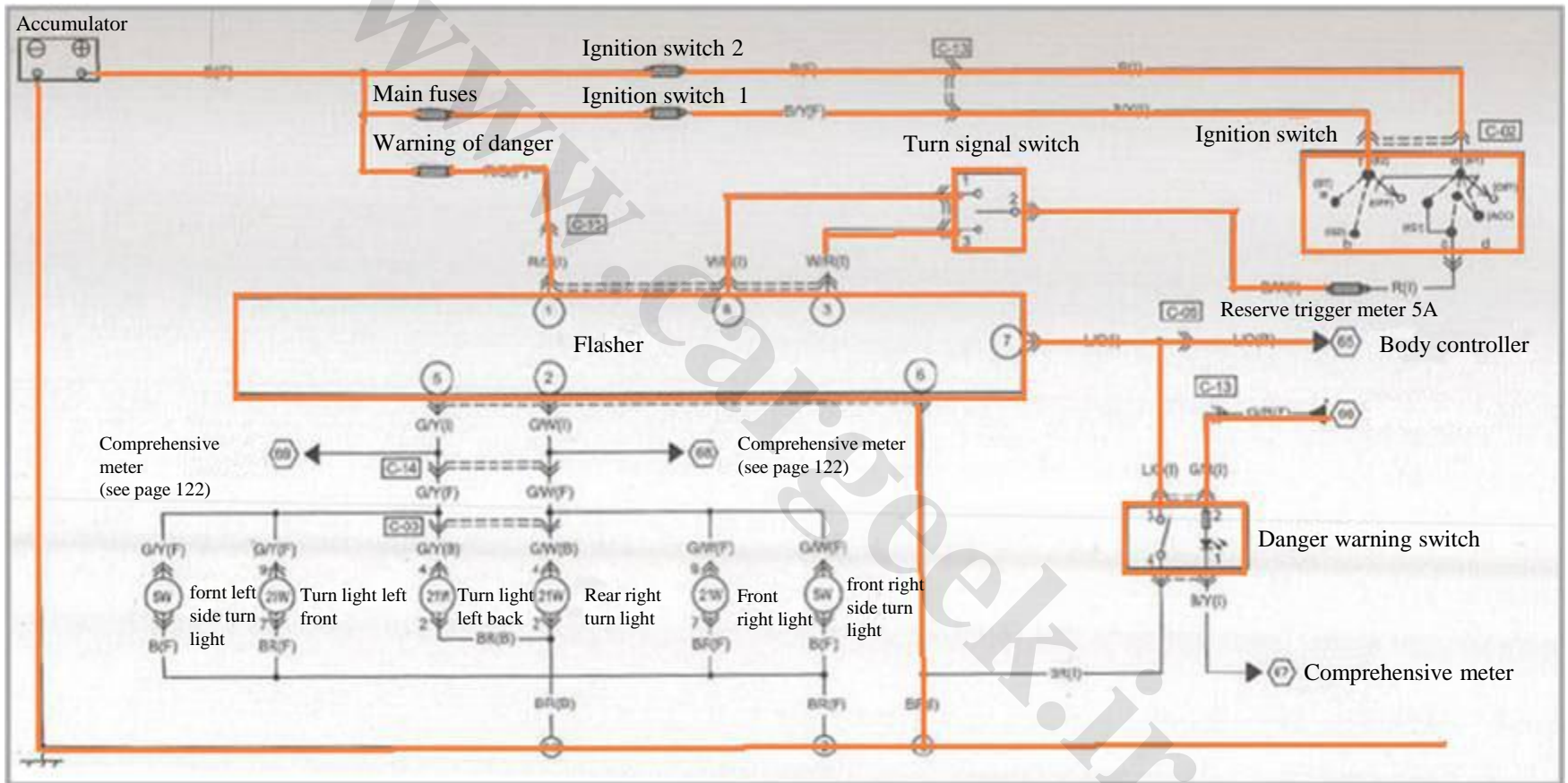

1. External lighting system

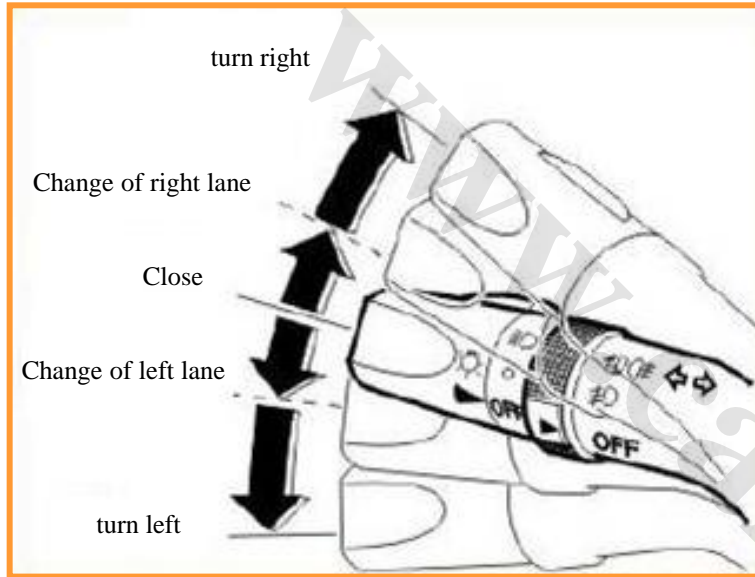

Turn light: when the turn switch is moved to left turn (or change lane to the left) position, the turn light on the left side will complete at least three times flickering actions. If during the flickering process, the turn switch is moved to the right turn position, the left turn light will immediately stop flickering and change to right flickering, vice versa. When the vehicle speed is more than 30km/h, the ignition switch is at ON position and the danger warning switch is pressed, if moving to the left/right turn light, there will be only signal light on the left side/right side flickering.

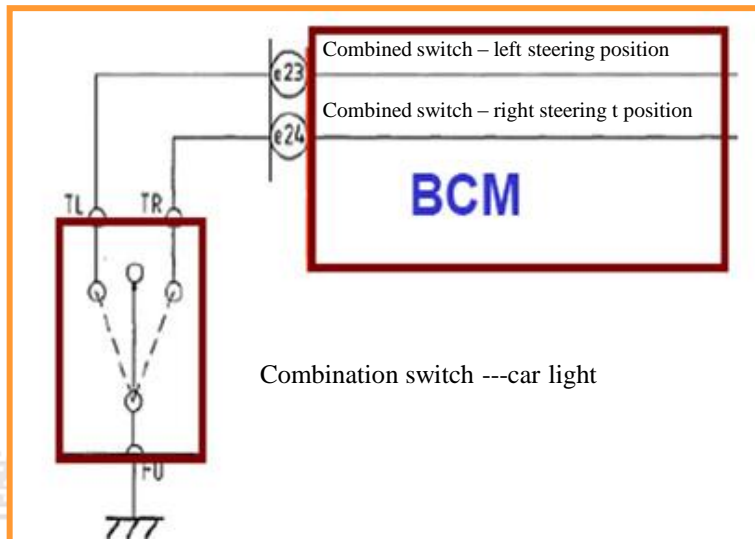

Turn light: the combination switch is switched on to the left/right turn light grade, BCM e23/e24 terminal is earthed, and BCM b14/b1 terminal outputs B+ to make the left/right turn light work.

1. External lighting system

1.7 Brake light and LED Module

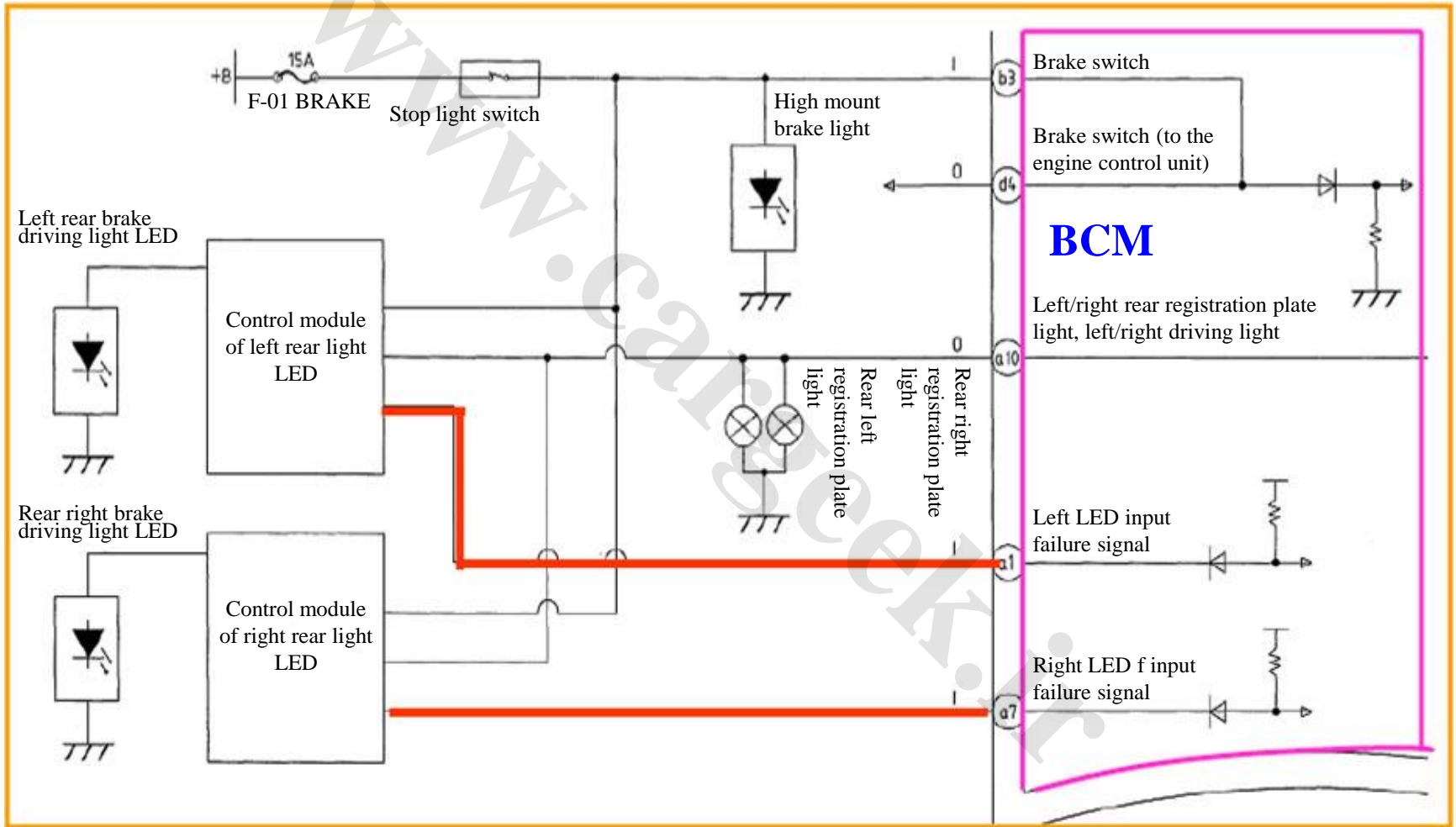

Control module of brake light LED

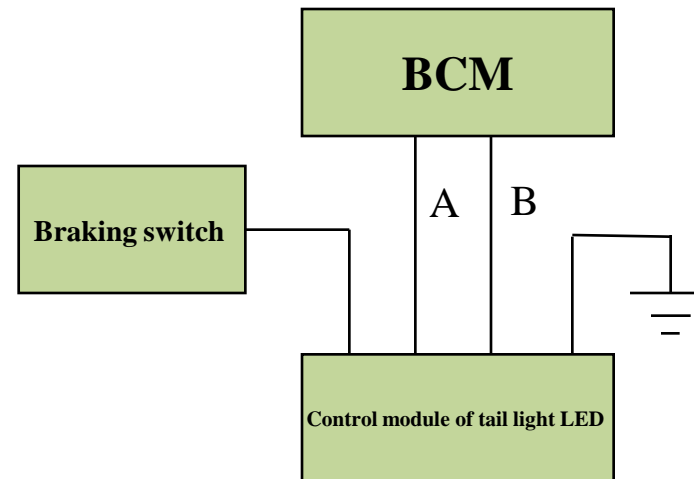
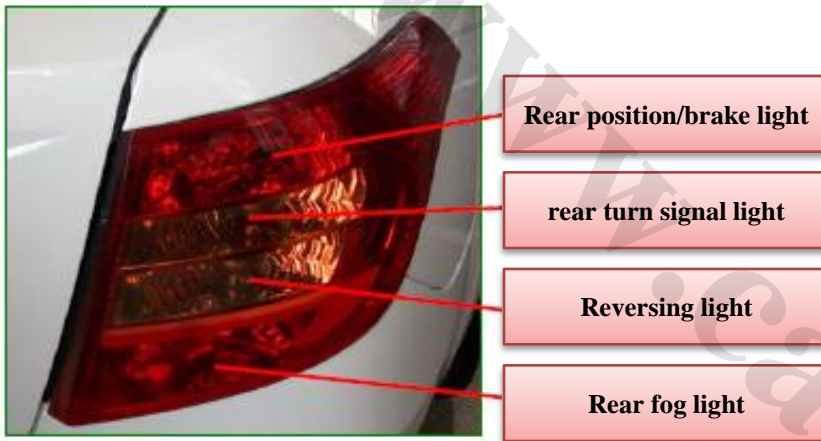

A: Fault detection signal

B: Tail light control

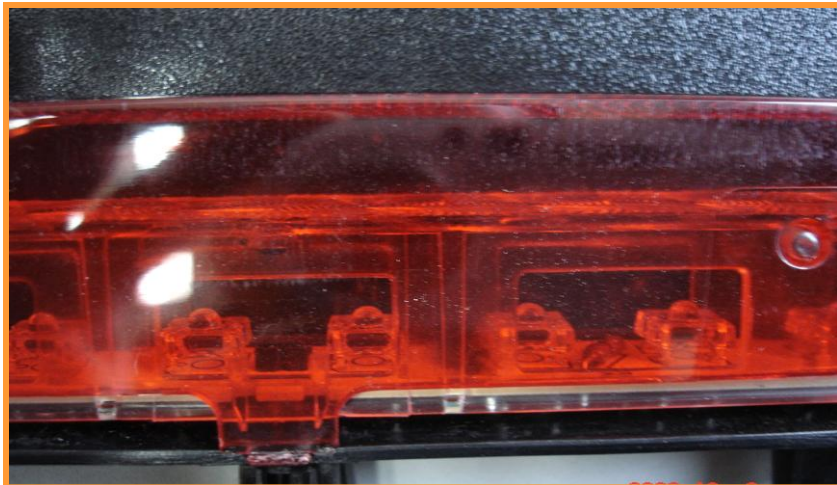

The control module of brake light LED is in the rear combination tail light. In case the left/right brake light have faults, the control module of the rear tail light LED will be monitored by a1/a7 of BCM through the feedback line and then determined by BCM, then finally output to the combination instrument to lighten the brake light fault indicator.

2.1 System Position Diagram of windshield Wiper/Scrubber

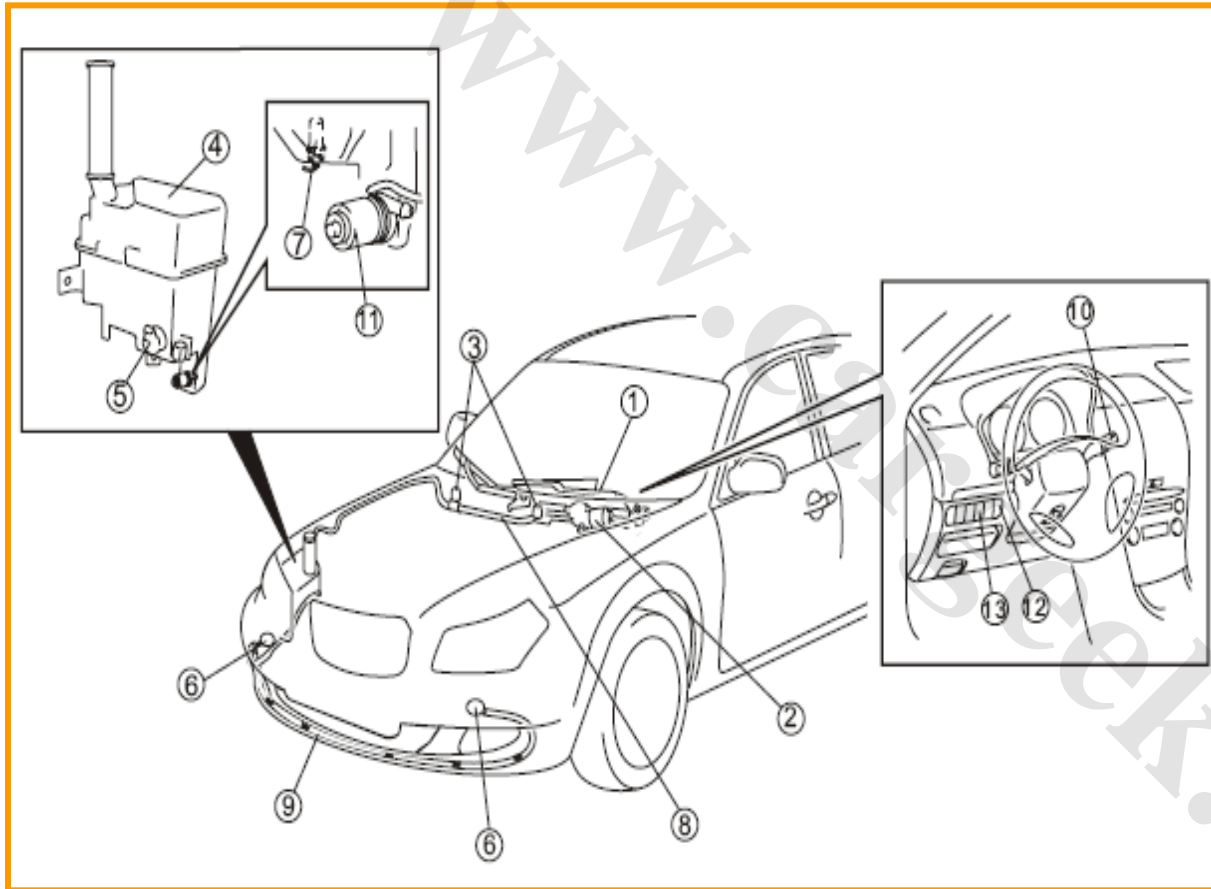

1	Arms and blades of windshield wiper
2	Windshield wiper Motor
3	Nozzle of windshield washer
4	Storage tank of the washer
5	Motor of windshield washer
6	Nozzle of headlight washer
7	Level sensor of the washer
8	Flexible pipe of the windshield washer
9	Flexible pipe of the headlight washer
10	Wiper and washer switches
11	Motor of the headlight washer
12	Switch of the headlight washer
13	Heating switch for the nozzle of the windshield washer

2.2 Schematic Diagram of B50 windshield Wiper Circuit

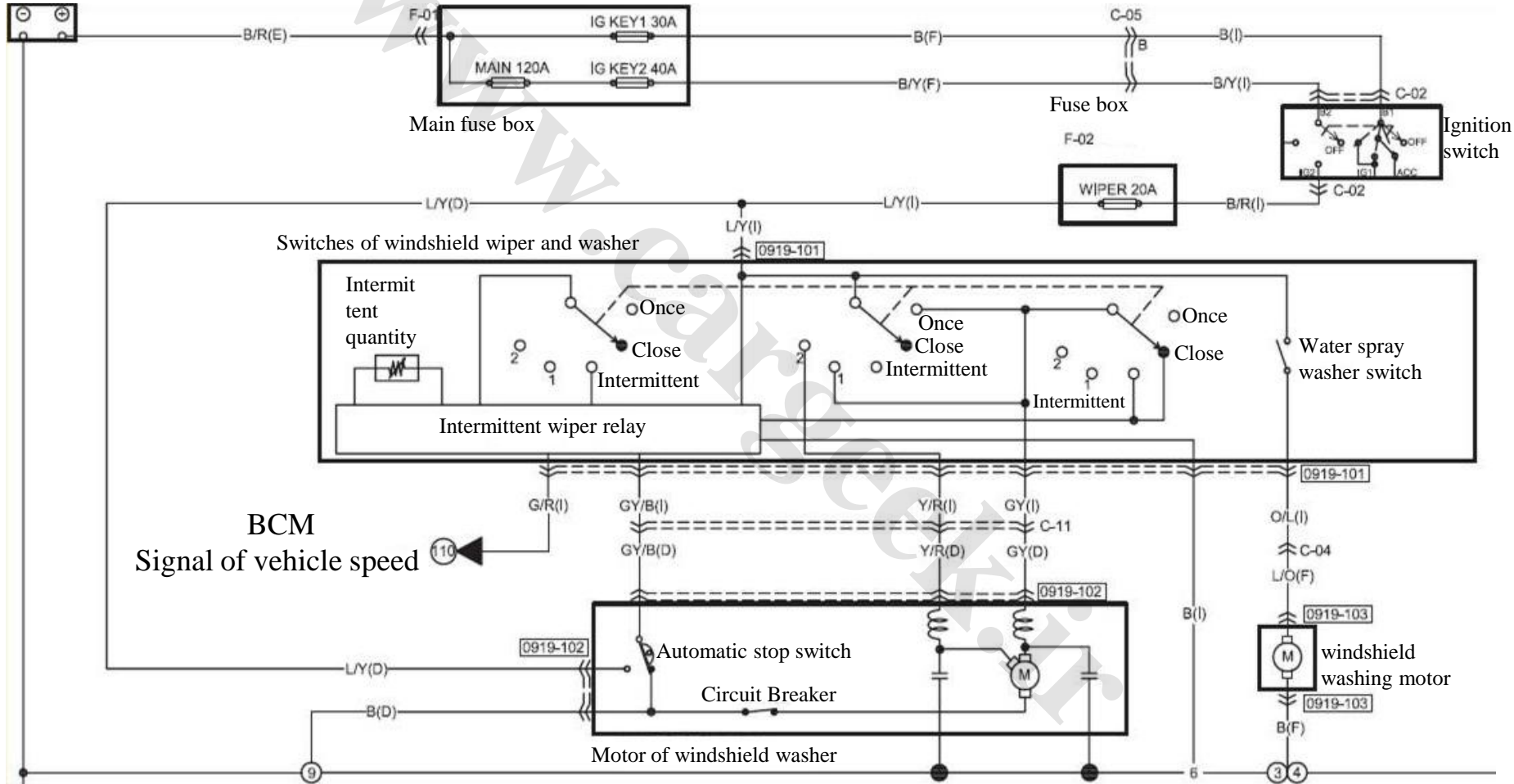

2.3 Wiper Switch of B50

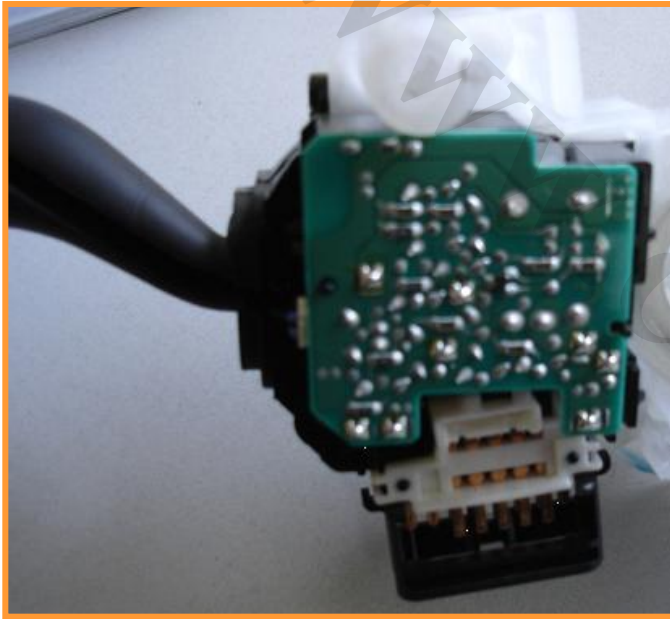

The wiper switch has control circuit inside

According to the speed signal, the intermittent wiper system will perform timing control as follows:

- When the speed is 0 mile/h:
 - (1) Maximum of INT ---- about one time per 11.6 seconds
 - (2) Minimum of INT ---- about one time per 4.2 seconds
- When the speed is 30 miles/h above:
 - (1) Maximum of INT ---- about one time per 9.6 seconds
 - (2) Minimum of INT ---- about one time per 1.1 seconds

2.4 Level Sensor of windshield Cleanout Fluid

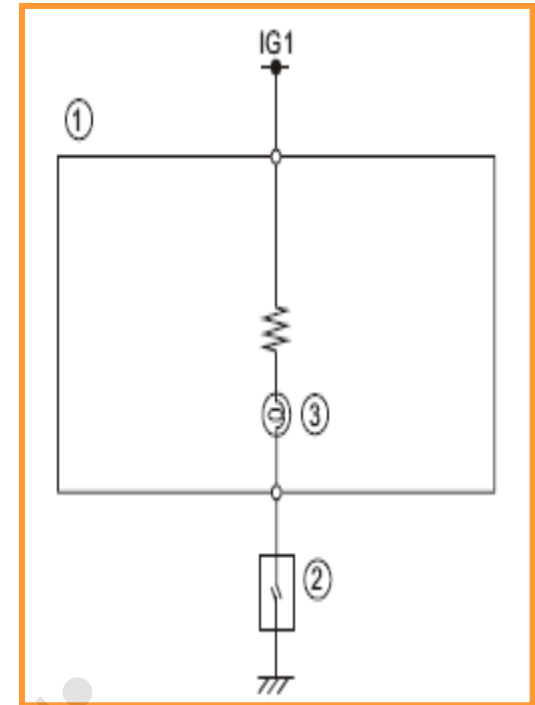
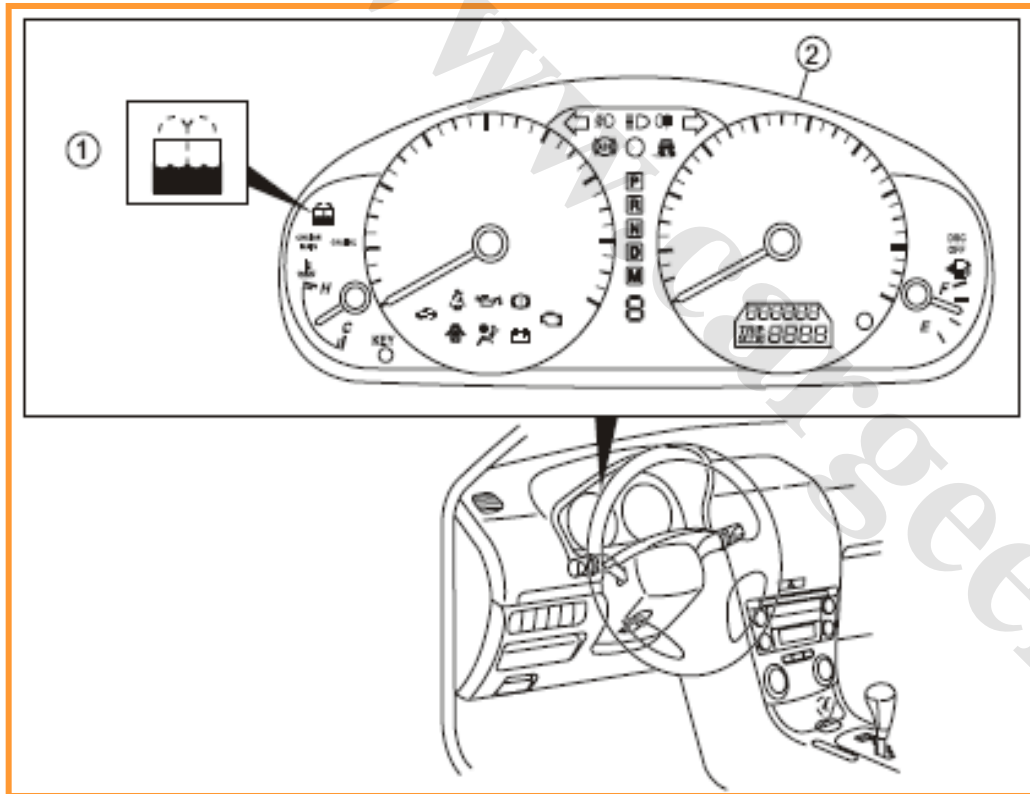











3.1 System Structure of the Instrument







Functional block diagram of the instrument system



3.2 Overview of the Combination Instrument and Meanings of the indicator light

No.	Function	Signal source	Figure	Color
1	Right turn	CAN		Green
2	Left turn	CAN		Green
3	Charging indicator	Rigid line		Red
4	High beam	CAN		Blue
5	Air bag	Rigid line/CAN		Red
6	Brake	Rigid line/CAN		Red
7	MIL Indicator light	CAN		Yellow
8	SVS indicator light	CAN		Yellow
9	Seat belt (driver)	Rigid line		Red
10	Door switch	CAN		Red

3. Instrument Display System

No.	Function	Signal source	Figure	Color
11	ABS system Failures	CAN		Yellow
12	Rear fog light	CAN		Yellow
13	Oil pressure	Rigid line		Red
14	Front fog light	CAN		Green
15	Engine security indication.	Rigid line		Red
16	Temperature alarm	CAN		Red
17	AT fault indication	CAN	AT	Red
18	Cruise MAIN	CAN	CRUISE MAIN	Yellow
19	Cruise Set	Rigid line	CRUISE	Green
20	DSC/TCS indicator	CAN		Yellow

3. Instrument Display System

No.	Function	Signal source	Figure	Color
21	TCS OFF	CAN	TCS OFF	Yellow
22	DSC OFF	CAN	DSC OFF	Yellow
23	Fuel oil level alarm	Rigid line		Yellow
24	Tire pressure alarm	Rigid line		Yellow
25	P stop gear	CAN	P	Green
26	R reverse gear	CAN	R	Yellow
27	N neutral gear	CAN	N	Green
28	D driving gear	CAN	D	Green
29	S sports gear	CAN	S	Green
30	M manual gear	CAN	M	Yellow
31	Indication of brake light fault	CAN		Yellow
32	parking light indicator	Rigid line		Green

3. Instrument Display System

3.3 System control circuit diagram

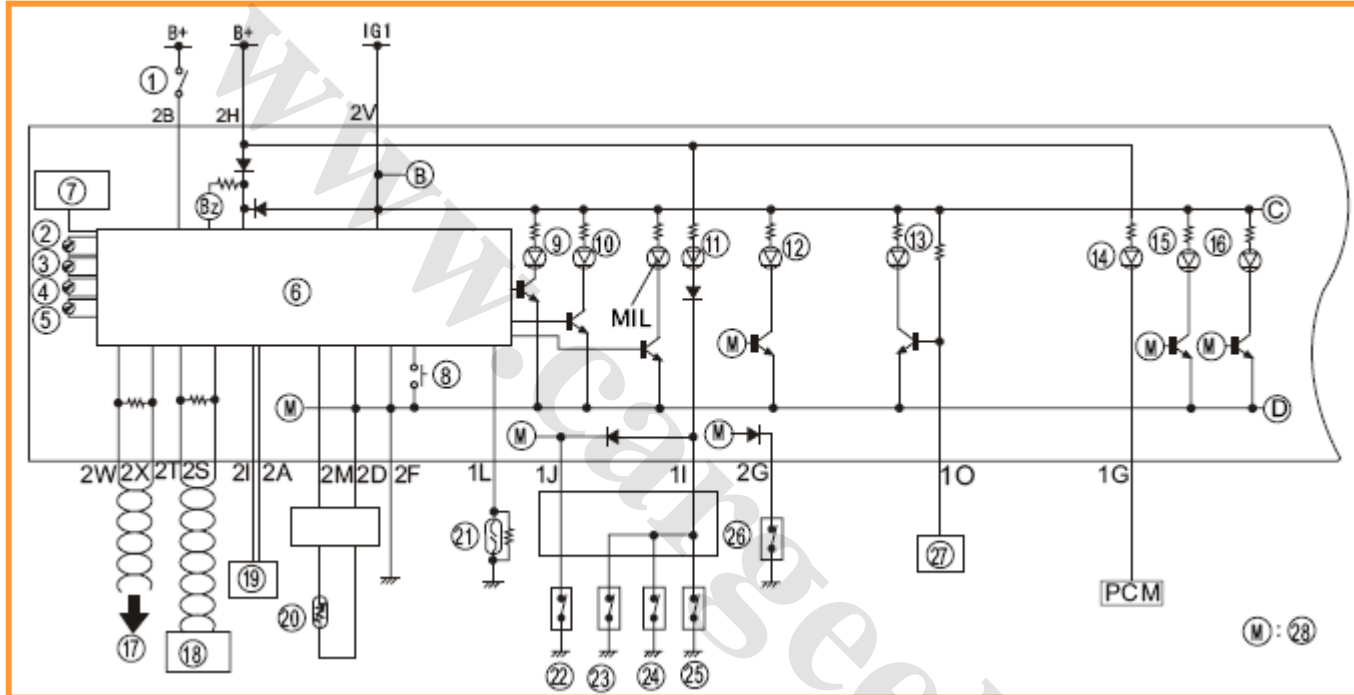

1	Key tip switch	8	Odometer/single-trip odometer	15	Indication light for cruising kit	22	Car door switch (at the driver side)
2	speed meter	9	Warn light for fuel level	16	Main indication light of cruising	23	Car door switch (at the co-driver side)
3	Tachometer	10	Signal light for generator alarm	17	Relevant modules of CAN	24	Car door switch (left rear door)
4	Fuel gauge	11	Alarm light for door open	18	Audio device	25	Car door switch (right/left rear door)
5	Water-thermometer	12	Alarm light for seat belts	19	Control switches of instrument board lights	26	Retaining ring switch (at the driver side)
6	Microcomputer	13	Alarm signal light for air bag restraint system	20	Signal transmitter of the fuel meter	27	SAS control module
7	Odometer/single-trip odometer	14	Safety light	21	Brake liquid level sensor	28	To microcomputer

3. Instrument Display System

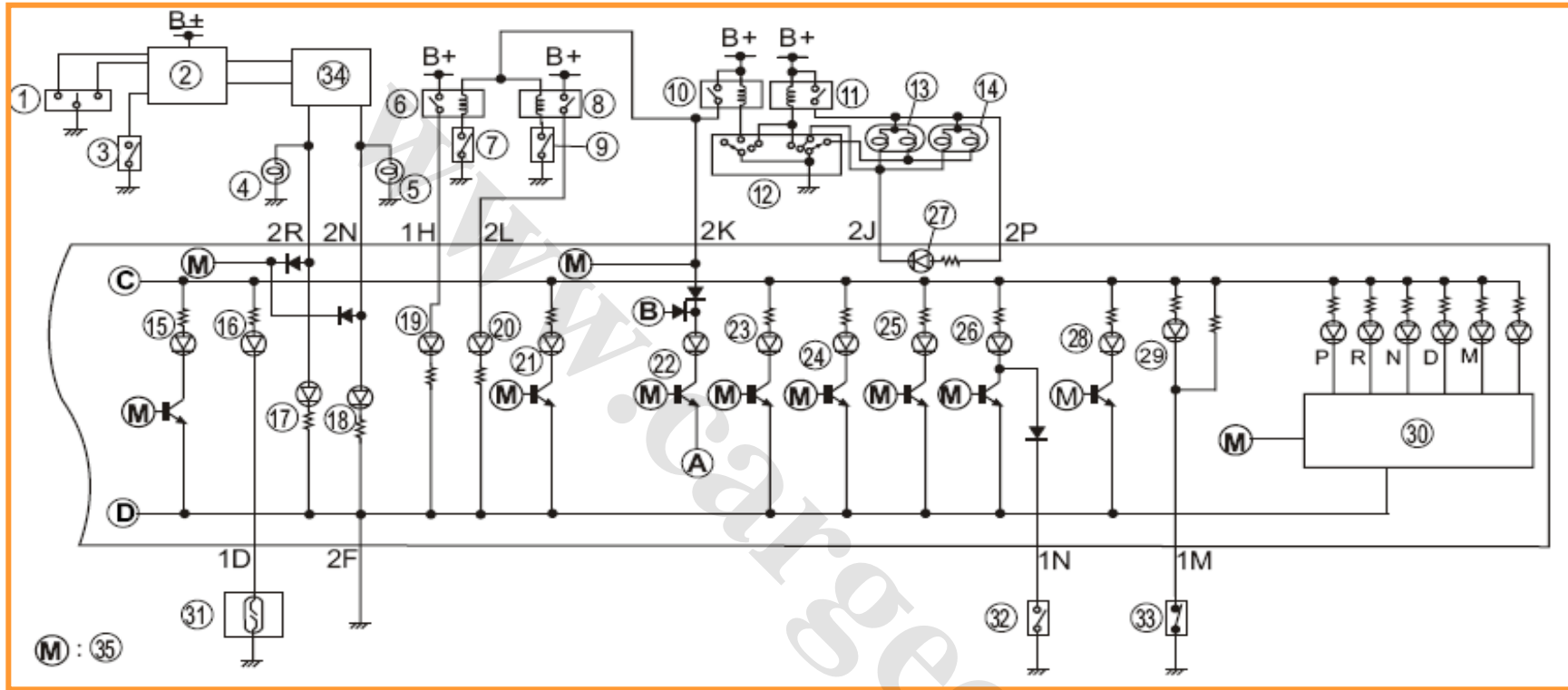

1	Steering switch	10	TNS relay	19	Indication light for front fog light	28	Oil pressure warn light
2	BCM	11	Headlight relay	20	Indication light for rear fog light	29	Indication light for distance light
3	Hazard warning switch	12	Headlight switches	21	Shining indication light	30	Driving circuit of pointer of the selector
4	Side turning light (left)	13	Headlight (left)	22	Instrument panel indication light	31	Level sensor of the scrubber
5	Side turning light (right)	14	Headlight (right)	23	DSC/TCS indication light	32	Parking braking switch
6	Front fog light relay	15	TCS OFF indication lights	24	DSC OFF indication light	33	Oil pressure switch
7	Front fog light switch	16	Warn light of scrubber liquid level	25	ABS alarm signal light	34	Steering light control unit
8	Rear fog light relay	17	Turn light indicator (left)	26	Alarm signal light of the braking system	35	To microcomputer
9	Rear fog light switch	18	Turn light indicator (right)	27	AT alarm signal light		

3.4 Display Functions of the Combination Instrument LCD (Clock Setting)

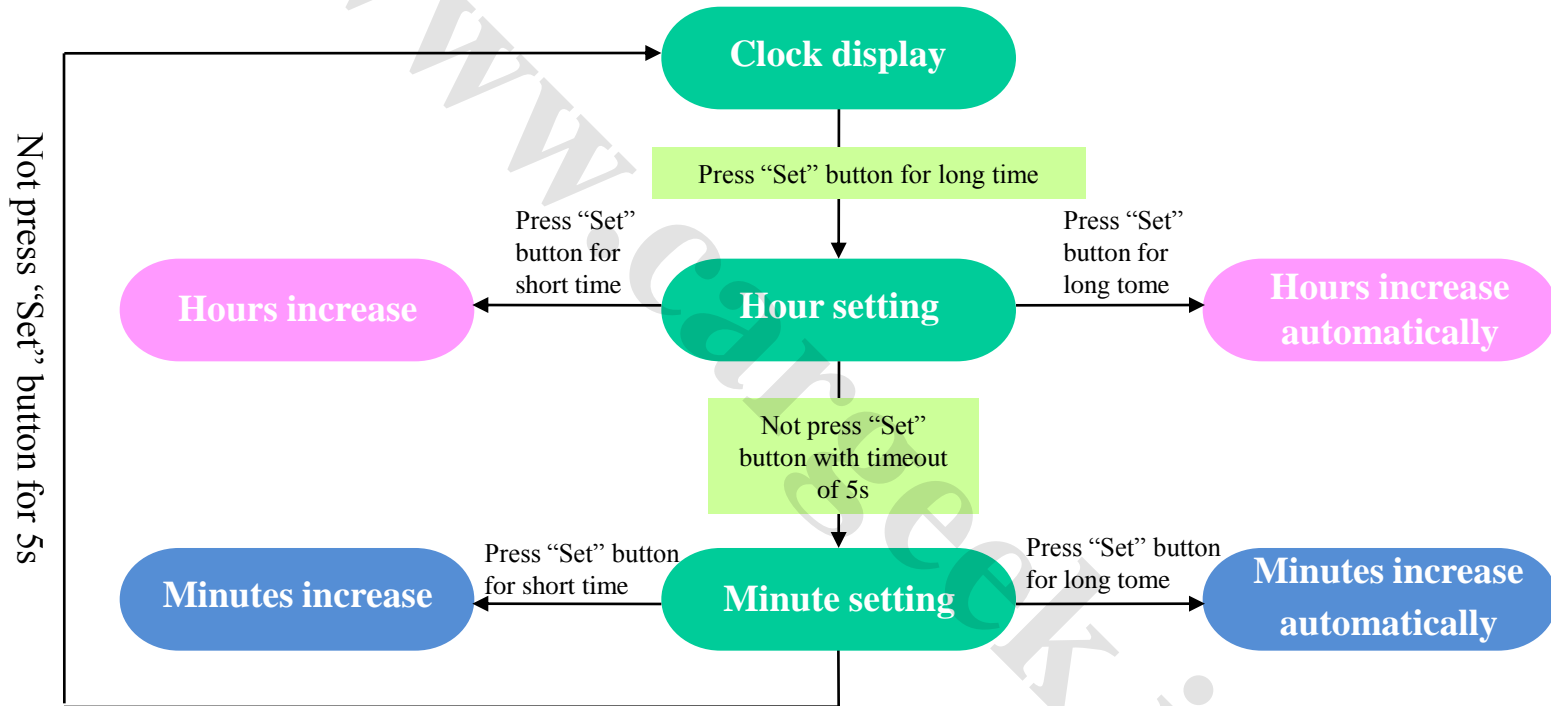

3.5 Method for Inspection of Input and Output of the Combination Instrument

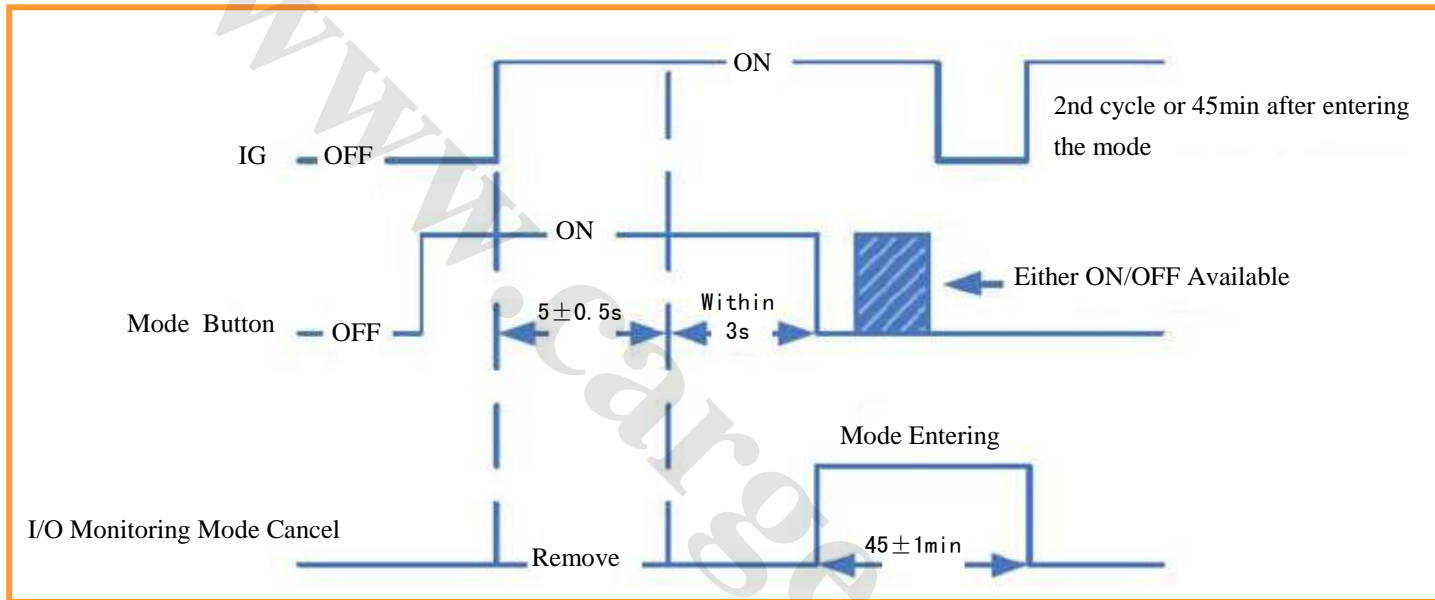

- Press “Mode” button
- Turn on the ignition switch, and simultaneously press the “Mode” button all the time
- Continue to press the “Mode” button for 5 ± 0.5 s, and the “TEST” will be displayed on LCD
- Within 3s of “TEST” display, loosen the “Mode” button
- Keep pressing the “Set” button and start to check the inspection codes (start from 01)

3. Instrument Display System

Method for inspection of input and output of the combination instrument (display method)

The input and output detection will be displayed at the positions of total mileage and subtotal mileage of the LCD screen and inspection codes and determination results will be displayed. The inspection code will be updated by pressing the “Set” button every time, and the inspection code will be updated at 2Hz by continuously pressing the button for more than one second. The LCD display positions are as shown in the following figure:



3. Instrument Display System

Inspection code

Ignition switch	Inspection code	Description
ON	01	Seat belt switch (the seat belt of driver, buckle up – On, loose-- OFF)
	04	Switch of door status (any one of the four doors is open, it will display ON, all are close, it will display OFF)
	08	TNS switch (TNS is open, it will display ON, if close, display OFF)
	12	Simulated speed signal (the speed meter goes up to the maximum speed, and then returns to 60km/h)
	13	Speed signal (the motor goes to the maximum speed and then returns to 3000rpm)
	14	Buzzer (the instrument buzzer chimes for three times)
	16	Low fuel alarm (the low fuel alarm light flickers for three times)
	22	Fuel input
	23	Fuel meter indication (pointer action: F — 1/2 — E — F)
	25	Water-thermometer (pointer action: H — 1/2 — L — H)
	26	Total/subtotal mileage display (the LCDs of combination instrument all display 8)
	50	Compensation mode of DIS fuel consumption
	51	DIS diagnosis mode
OFF	59	Fault records of the fuel display system (display between 000 and 111, normal is 000)
	31	Keyless switch (if the key is in the ignition lock, display ON, if pull out, display OFF)
	33	Turn signal input (if press down the danger alarm switch, display ON, otherwise, display OFF)

4.1 Position Diagram of Audio System Elements

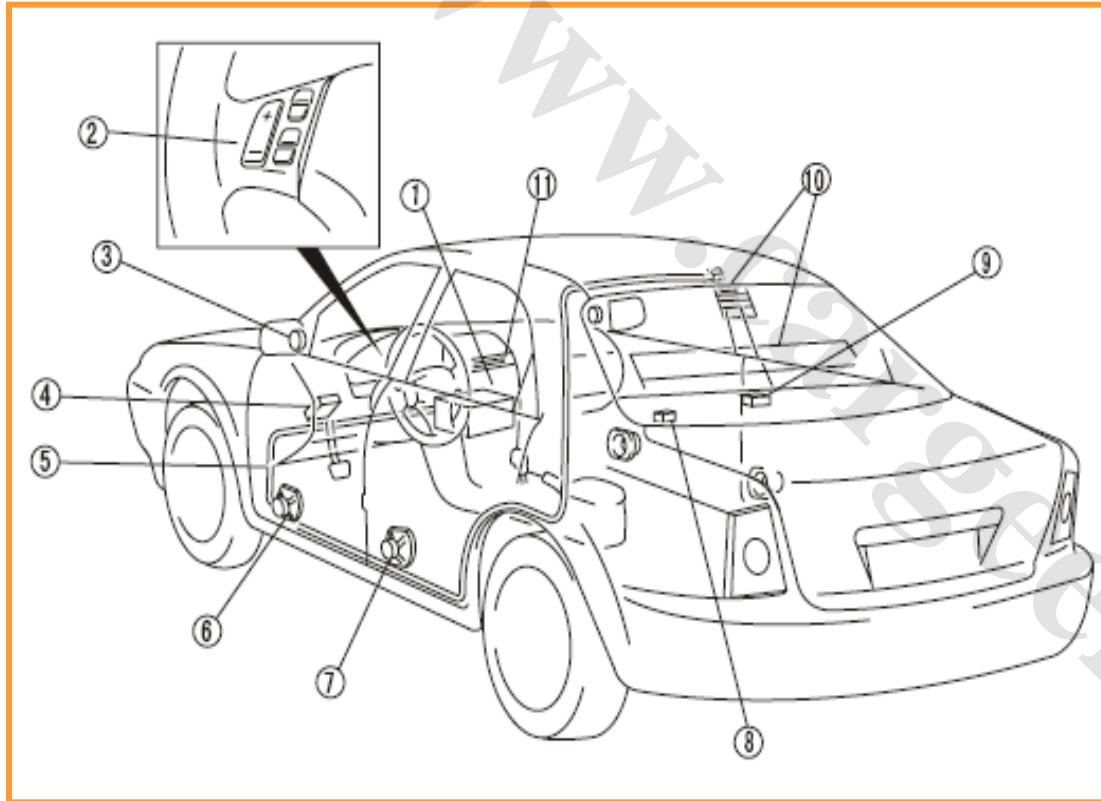

1	Audio units
2	Audio control switch
3	High pitch loudspeaker
4	Noise filter (brake switch)
5	Wireless feeder
6	Front door loudspeaker
7	Rear door loudspeaker
8	Noise filter
9	Noise filter (rear window frost removal)
10	Window-type antenna
11	Information display

4. Audio and Entertainment System



4.2 Overview of Audio System

Two types:

Type A: stereo radio and single plate CD plus MP3 (divided into two kinds: with external temperature display, and without external temperature display)

Type B: stereo receiver and virtual six plates CD plus MP3, the basic type is equipped with two loudspeakers, the comfortable and luxury types are equipped with six loudspeakers.

Basic functions	Spec		
	Type A	Type B	remark
Sound reception function			
AM	<input type="radio"/>	<input type="radio"/>	Frequency range: 522KHz~1620KHz
FM1/FM2	<input type="radio"/>	<input type="radio"/>	Frequency range: 87.5MHz~108MHz
Automatic radio station saving	<input type="radio"/>	<input type="radio"/>	Automatic searching and storing of radio station with strongest signal
Radio station browse	<input type="radio"/>	<input type="radio"/>	Browse time: 10s
Forwards/backwards searching of radio station	<input type="radio"/>	<input type="radio"/>	Forward: in the direction of frequency increase; Backward: in the direction of frequency decrease
Manual tuning	<input type="radio"/>	<input type="radio"/>	AM step length: 9KHz; FM step length: 100KHz
Manual radio station saving	<input type="radio"/>	<input type="radio"/>	Each level of AM/FM1/FM2 can be respectively set with six station radios
CD functions			
Automatic in-drawing of disc	<input type="radio"/>	<input type="radio"/>	Types of disc supported: CD、CD-R、CD-RW、MP3
Exit of disc	<input type="radio"/>	<input type="radio"/>	
Forwards song searching	<input type="radio"/>	<input type="radio"/>	Forward: in the direction of list number increase
Backwards song searching	<input type="radio"/>	<input type="radio"/>	Backward: in the direction of list number increase
List browse	<input type="radio"/>	<input type="radio"/>	Each song is played for 10s in orders
Random play	<input type="radio"/>	<input type="radio"/>	
Fast forward/fast backward	<input type="radio"/>	<input type="radio"/>	
Repeat play	<input type="radio"/>	<input type="radio"/>	Single repeated play, all repeated play

4.3.1 Single CD player/visual six CD player penal

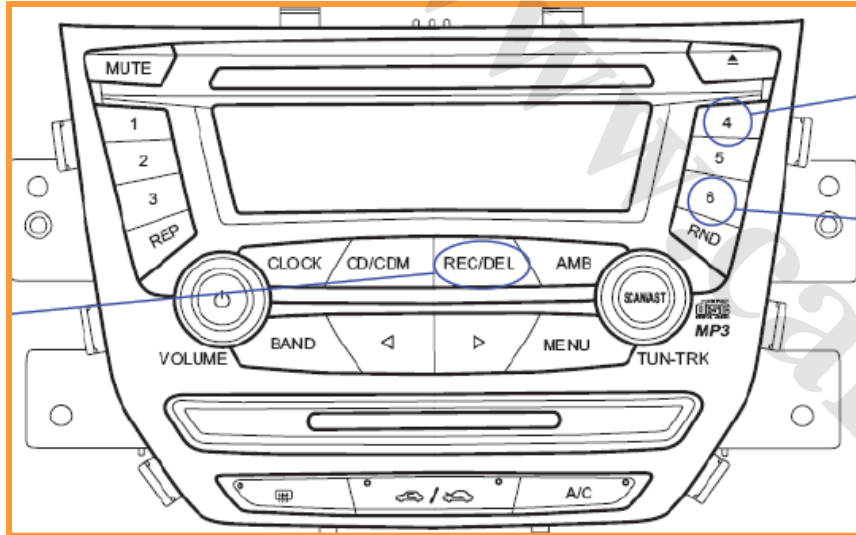

➤ Recording

In CD status, long pressing REC/DEL key can store the songs on the CD disc into the radio and tape player. When the recording is not finished, if exit required, press CD/CDM or BAND key, and the next recording will start from the un-finished song of last time, and at most, it can store contents of six standard CDs in orders. When recording, the default is to play the current recorded contents, but it can choose to play other stored visual discs.

➤ Editing

In CDM status, short-press REC/DEL to enter CDM editing mode, at this time, the display screen will have DELETE X. It will prompt, to press “4” to confirm the deletion. Press “6”, editing mode will exit. 3. In CDM mode, short press 1-6 means to play the stored 6 areas of visual discs.

4. Audio and Entertainment System

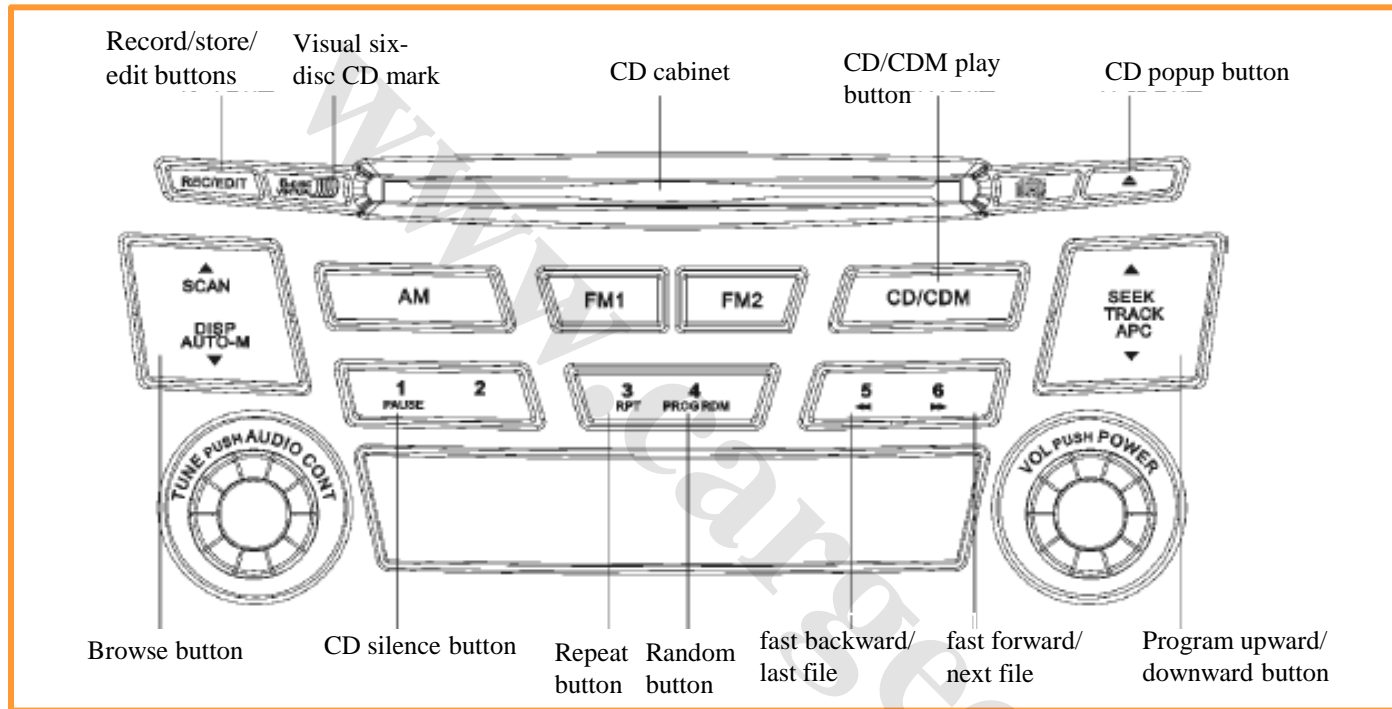

- Self-diagnosis functions of signal disc/visual six-discs CD machine
- After the sound equipment is open, press AM button and M6 button at the same time, the system will enter into the automatic diagnosis mode. The sound equipment will automatically drive four loudspeaker, and at the same time, the information displayer displays FL/FR/RL/RR (left front/right front/left rear/right rear) in orders, the corresponding loudspeaker will give out sound, thus to judge whether each sound channel of power amplifier works normally. After the test is completed, press any key to exit, in case of no operation, after about 5 seconds, it will automatically exit and switch to acoustic status.

4.3.2 Navigation DVD



- When the host is inserted with new SD card, click “NAVI” navigation switching key, and the system will enter the “Activate System” picture. The function is used to inquire the feature code of the navigation equipment and input the activation code of the navigation system.
- When inputting the correct system activation code, click the “OK” button on the lower right corner, and the navigation system will start.

4.4 Description of Car Bluetooth System

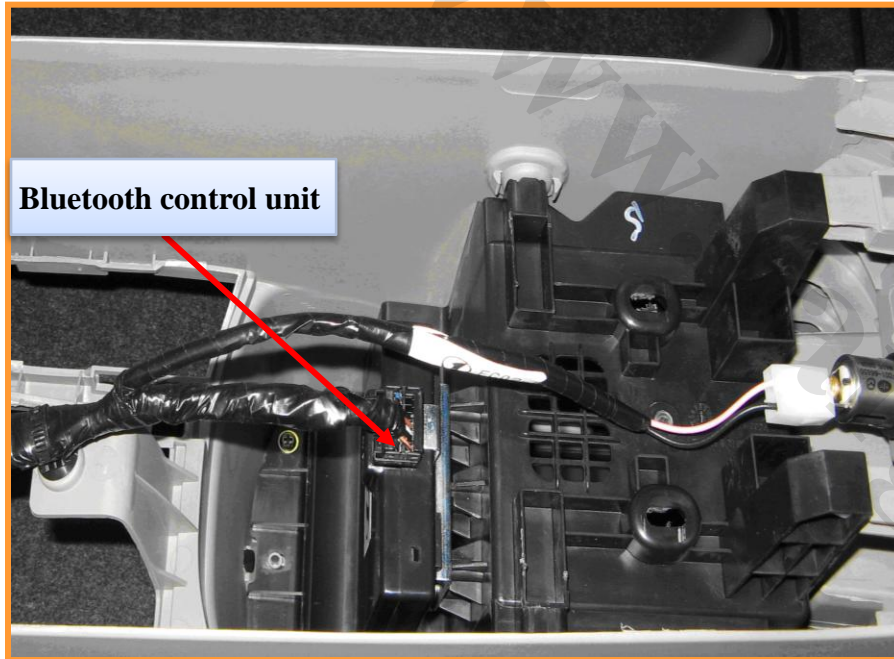

The blue tooth module combines the blue tooth phone, vehicle audio and internal microphone of the rearview mirror as a wireless hands-free phone communication system by wireless blue tooth communication protocol to realize phone functions of dialing and answering.

The control system of blue tooth phone is composed of the control module of the blue tooth phone, audio, internal rearview mirror assembly (there are microphone, caller ID displayer, blue tooth functional buttons on the internal rearview mirror), loudspeaker, steering wheel control buttons as well as the blue tooth phone of the user.

4. Audio and Entertainment System

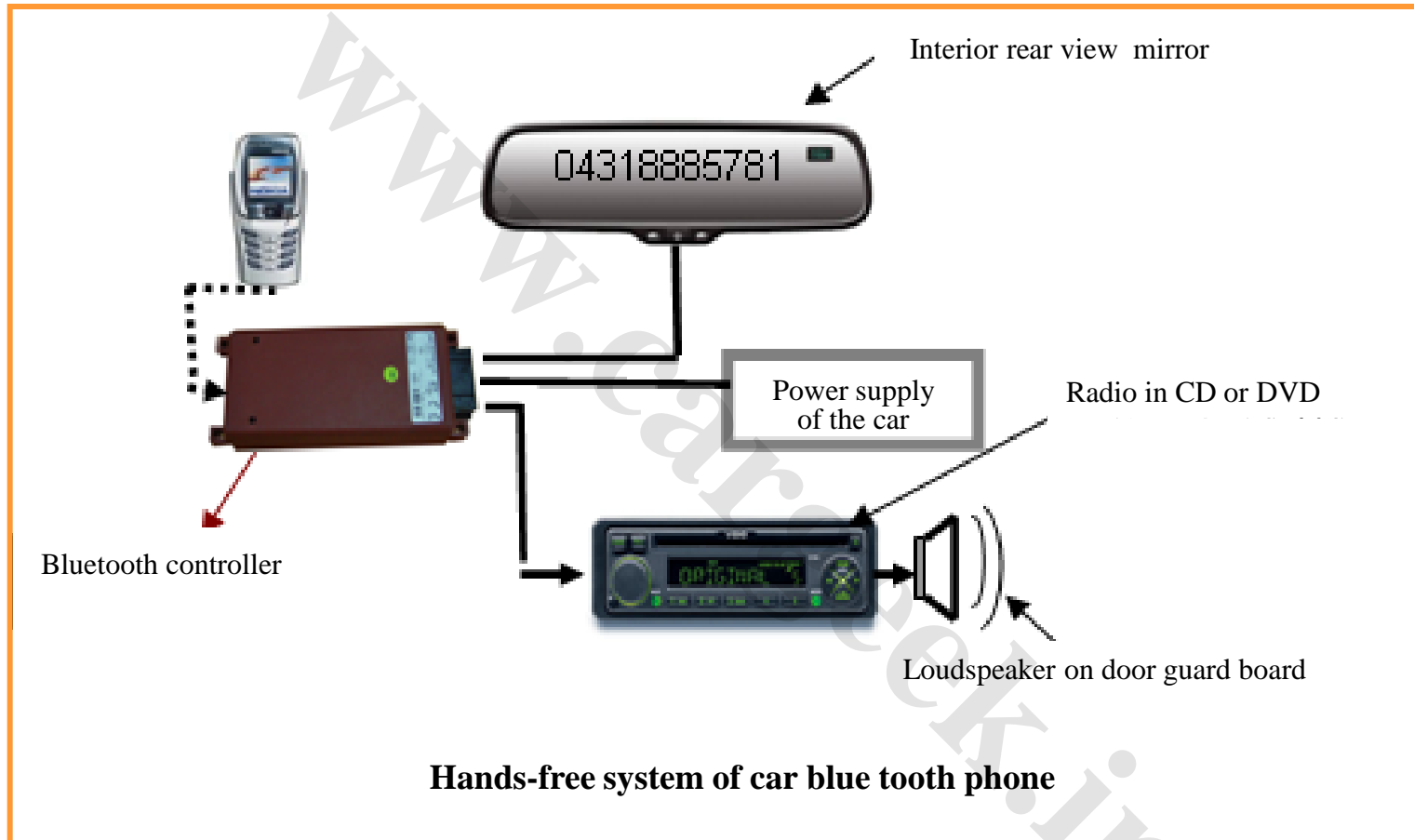

Main components: bluetooth controller, audio (including door loudspeaker and information display), internal rearview mirror and relevant circuits.

Car electrical system --- car bluetooth



1. Reversing radar display area

2. Caller ID display area

3. Compass display area

4. Answer buttons

5. Hang-up and voice dialing buttons

6. LED indication light

7. Voice entry of the microphone

8. Anti-dazzling light inlet window

9. Anti-dazzling switch, secrete answering button, secrete and hands-free switching buttons

10. Compass reversing radar display switch, long press for 15 seconds to close the direction display, long press 3-4 seconds to enter the magnetic area to choose, and long press for 6 seconds to enter automatic calibration of compass direction.

Car electrical system --- car bluetooth

Method for initial matching operation: (first use)

Step 1: switch on the power supply in the car, and at the same time, short-press the answering key and the hang-up key in Figure 2. and the radio will sound a series of “DU D U---” At the same time, the display screen of the radio will flash “PHONE”, which means the started the matching function of the car bluetooth hands-free system. As shown in Figure 1-1 }.



Step 2: it needs to set the phone bluetooth at open status.

Step 3: select phone function directory and enter the bluetooth subdirectory to start to search the car bluetooth.

Step 4: enter the directory of hands-free or matching devices

Step 5: seek new equipment and search car bluetooth signals.

Step 6: By successful searching, the current equipment displays as “fawcar-Besturn”.

Car electrical system --- car bluetooth

Step 7: after connecting such equipment, the phone will prompt to input the equipment identification password.

Step 8: input 1234, click the “OK” key on the phone to confirm the connection. With successful connection, the display screen of the radio will flash “PHONE”.

Step 9: exit.

Note: the replacement and matching of the phone or bluetooth device shall be carried out according to the matching steps to the system for the first time. After the matching is completed, if the matched phone or blue tooth device is not changed, these steps do not need to repeat for each application.

5.1 System composition

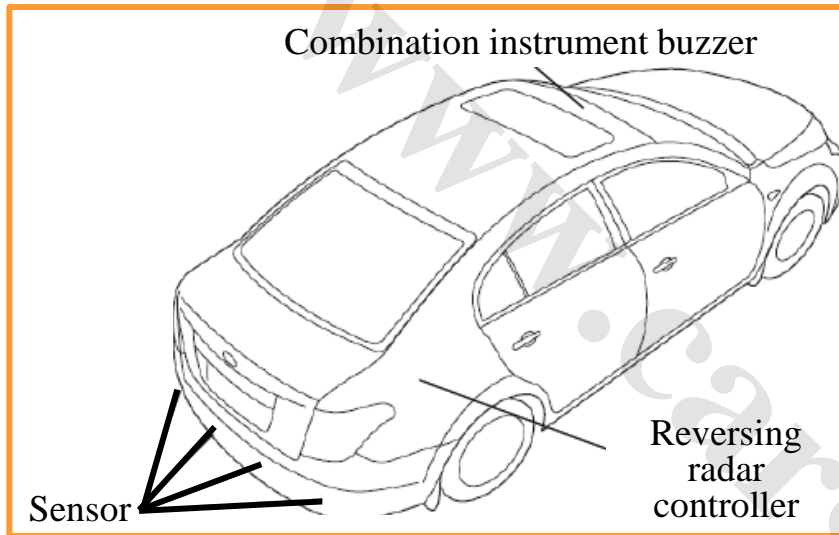



- Ultrasonic sensor (radar detector) (four)
- Reversing light switch
- Reversing radar module



- Intelligent internal rearview mirror
- Reversing radar display
- Compass direction display

Functions of reversing radar alarm

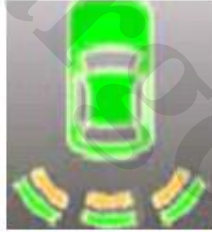
Move to the reversing gear, the buzzer gives out two prompts of “Bi Bi” sound, it means the startup of the reversing radar system is normal. In terms of inspection of big barriers of walls, the alarm distance is divided into three sections, and the prompting mode is as follows:

	Section I	Section II	Section III	
Distances	10~45cm	45~90cm	90~150cm	>150cm
Buzzer	Ring	8/1 second continuous tone	1/2 second continuous tone	No buzzing
Internal rearview mirror display				
	Orange green light is on Red light flashes	Orange green light is on	Green light is on	

If the left side inductor detects barriers, the left light will flash; if the right side inductor detects barriers, the right light will flash; if the middle two inductors detect barriers, the middle light will flash; if there is no barrier behind the car, only the small light will flash.

5.2 System composition

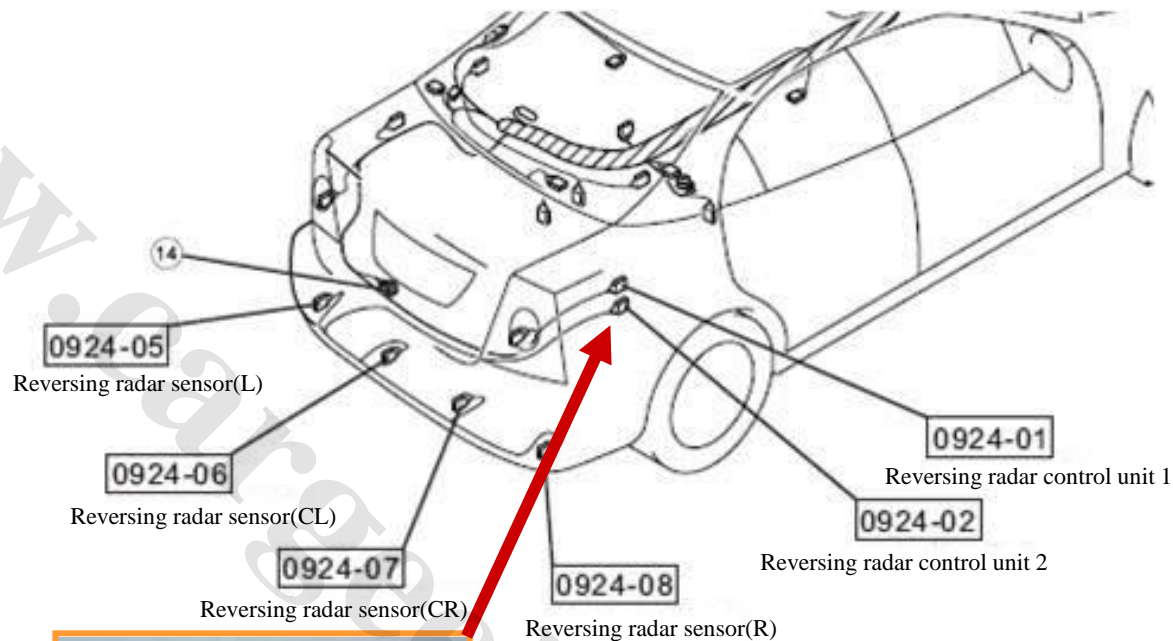
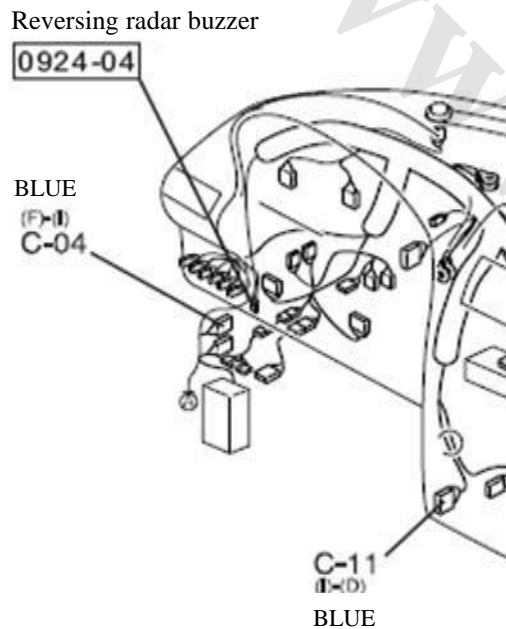

5.3 System control circuit diagram

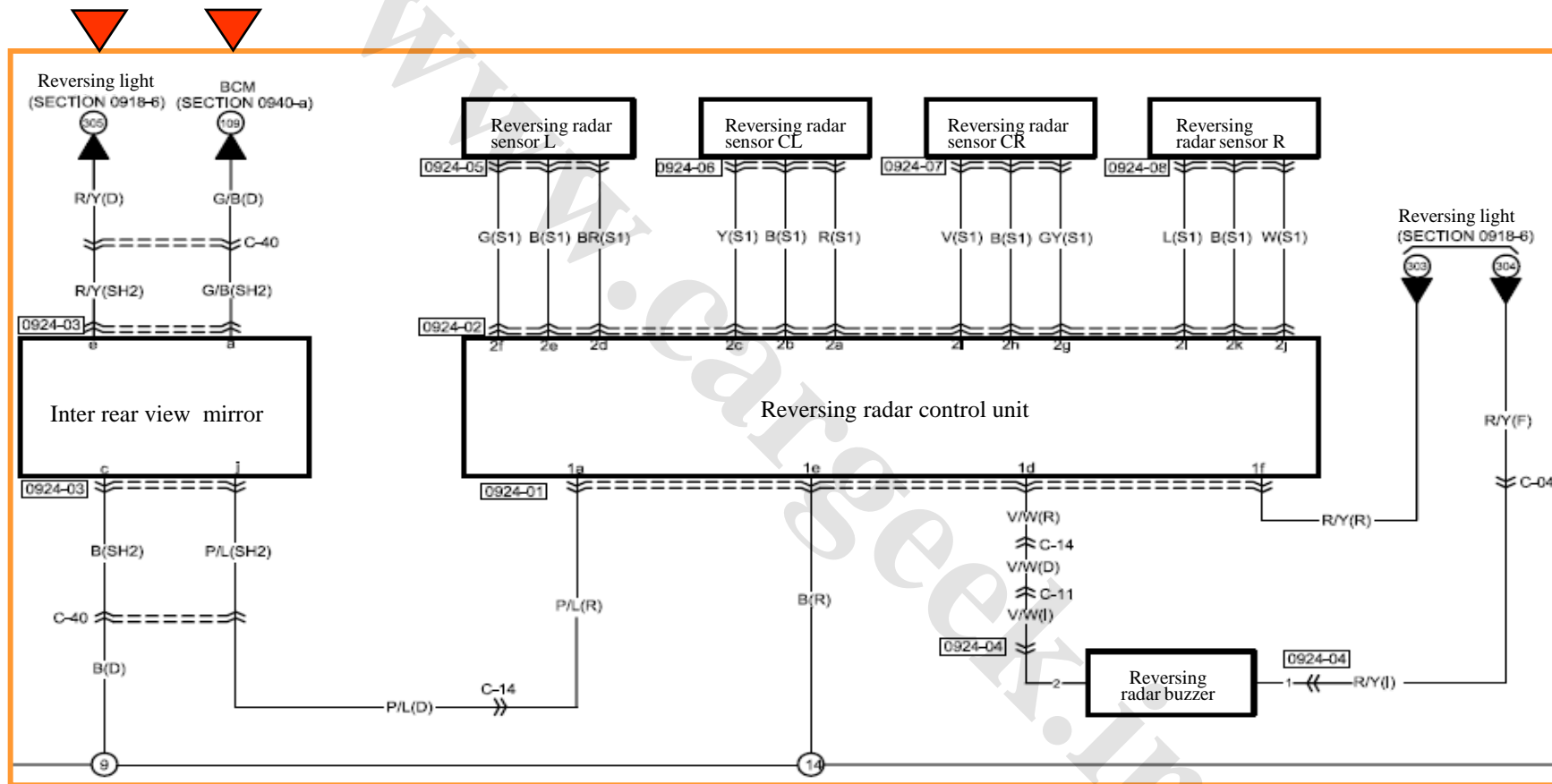

5.4 Internal Rearview Mirror Compass --- Compass Initial Setting



Reversing display area

Compass display area

When the ignition switch is at the ON position, press the key on the rearview mirror for more than five seconds, and loosen the key, the display area will display “C”. Then perform ring-form 360° traveling of the car, and the compass will automatically identify the direction. When the display area displays some direction, it means the compass initialization completes.

5.5 Reversing radar sensor



On the rear bumper, there is installed with four ultrasonic sensors.

Principle: transmit to the rear of the car by utilizing the ultrasonic wave generated by the ultrasonic sensor, if meeting some objects within certain range, there must be a reflected wave back to the emission source (surface of the ultrasonic sensor). By utilizing the delay time and the sound wave velocity between the transmitting wave and the reflected wave, it can measure the distance.

5. Reversing Radar System

Working principle of the reversing radar sensor

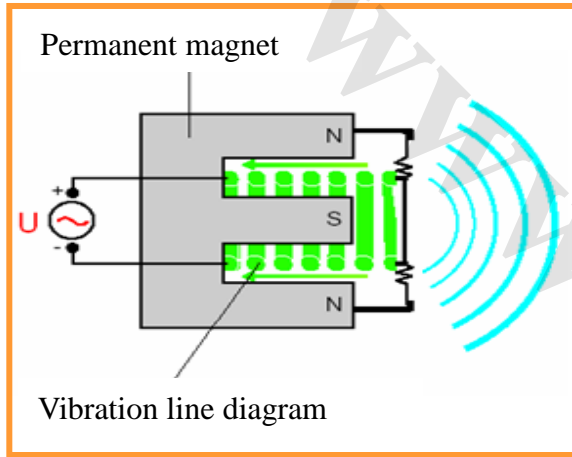

Transmitting signal of the reversing radar sensor

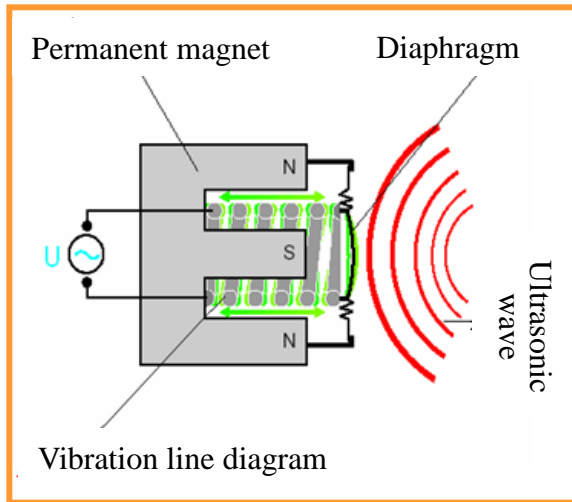

Receiving signal of the Reversing radar sensor

It dose not give out alarm when approaching to the barrier

If it dose not give out alarm even approaching to the barrier,
please first check the following points:

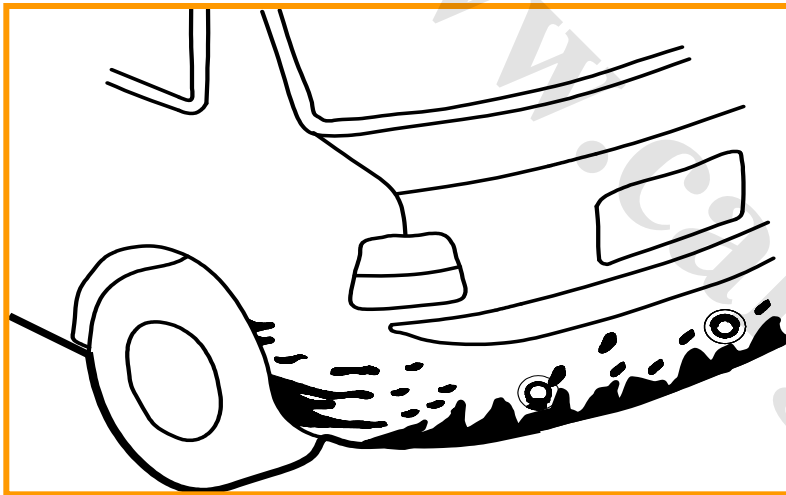

- Whether the upper surface of the radar detector is adhered with snow or mud; When the radar detector surface is adhered with snow or mud, the detection performance of the radar detector will decline prominently. At this time, it can use cloth to wipe or use water (low water pressure) to wash off the snow or mud adhered on the surface of the reversing radar detector.

Attention:

Please do not use high-pressure hydraulic giant for washing. The high-pressure water flow of the hydraulic giant or big external force may cause defaults.

It dose not give out alarm when approaching to the barrier

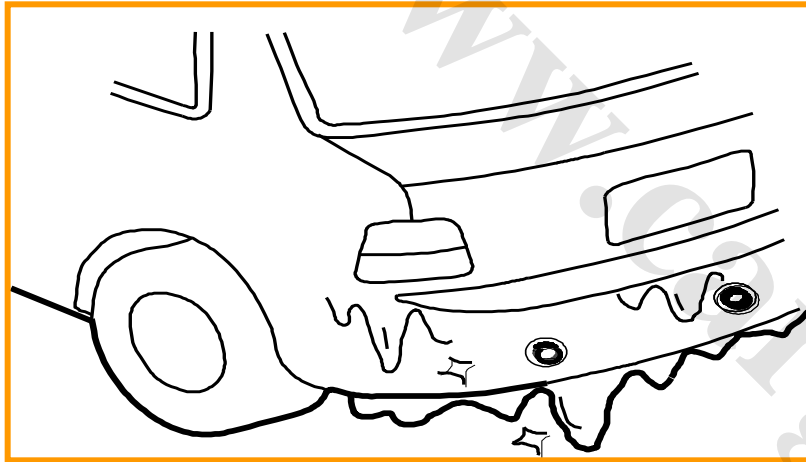

- Whether the upper surface of the radar detector has freeze ;
In terms of freeze, it will also seriously reduce the detection performance. Maybe the failure of alarm belongs to normal phenomena. At this time, it can slightly remove the ice.

Attention:

Please never use fire to melt ice or use metal objects to heavily knock the ice, so as to prevent damaging the detector.

- Whether the vehicles are stopped for long time in hot or cold whether;
The detector may not be able to work normally below -20°C or above 50°C .

It dose not give out alarm when approaching to the barrier

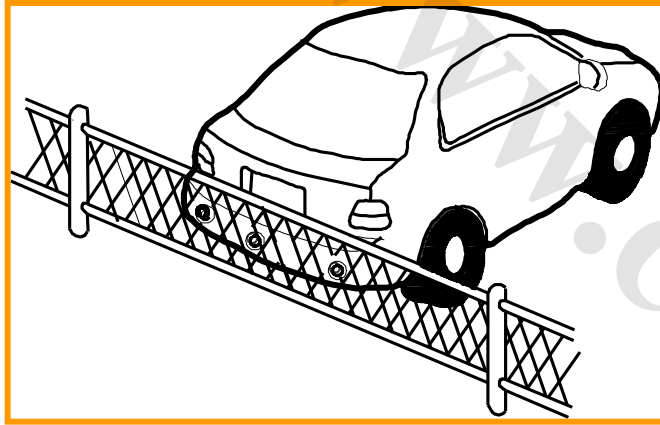

- Whether approaching to fine objects of iron wire, ropes and cell walls etc;
It may not give out alarm when approaching lower objects, and this belongs to normal phenomenon.

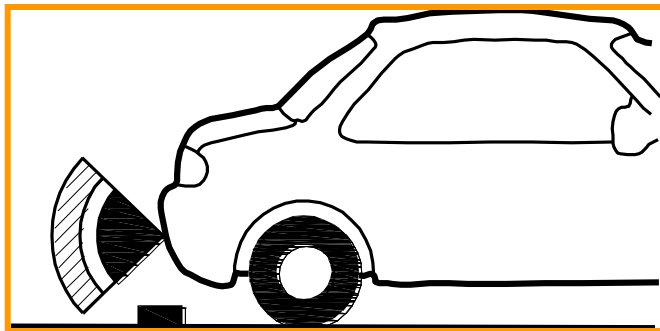

- Whether the approaching barrier is too low;
As the radar detection has range limit, it may not give out alarm when approaching such objects and this belongs to normal phenomenon.

It dose not give out alarm when approaching to the barrier

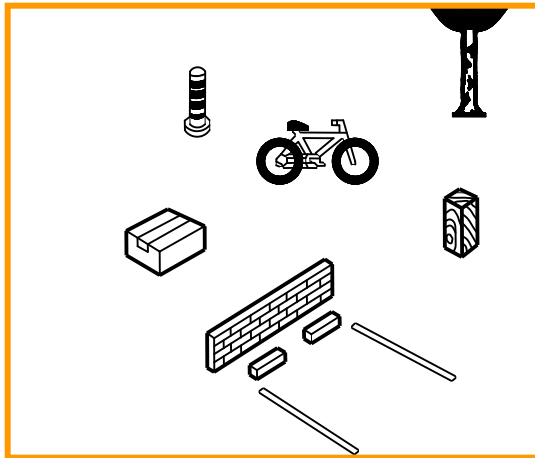
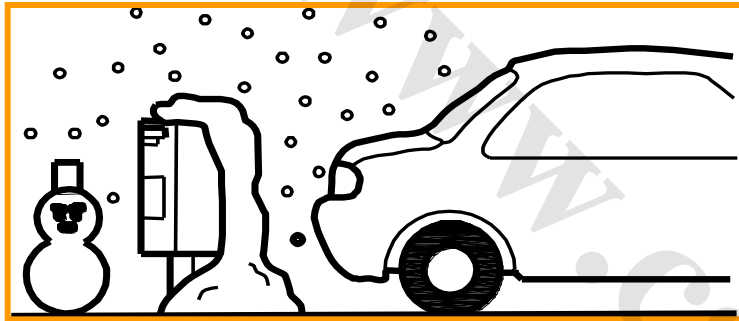

- Whether approaching to objects of soft snow, cotton and sponge that are easy to absorb ultrasonic wave; As absorbing ultrasonic wave, it may not give out alarm when approaching such objects, and this belongs to normal phenomenon.
- In terms of objects that are difficult to reflect ultrasonic wave, according to the shape of the barrier, it may not give out alarm;

Except the above-mentioned phenomenon, it may be because the radar detection system has fault, for example:

- The detector is damaged and cannot work;
- The wire bundle is broken off;
- The plug is loose;
- Communication fault;
- Instrument failure .

Mistake alarm

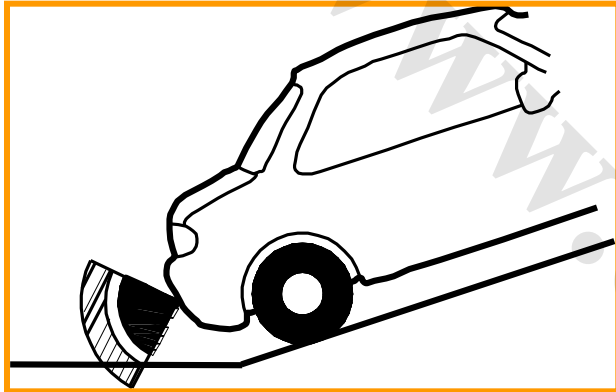

- Downward abrupt slope;

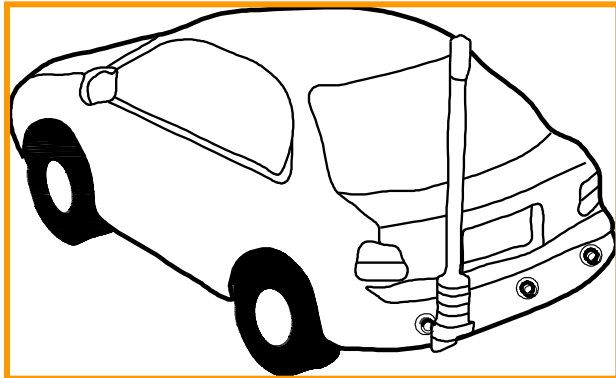

- Installed with and use high output radio or antenna;

Mistake alarm

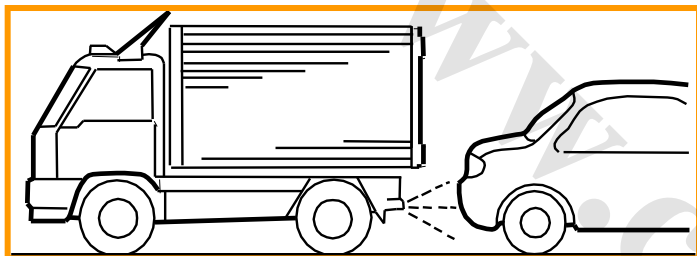

- When objects approach, including trumpet of other cars, engine noise of motorcycles, air braking sound etc;

www.cargeek.ir
Thank you!

Technical Training of BESTURN B50

Auto-body electrical System (C)

奔腾 BESTURN

Suitable Post: CTO

Curriculum Goals

- Familiar with the Basic information of Auto-body electrical System
- Grasp the Analytical Reading Method of Schematic
- Familiar With the Position, Function and the Characteristic of Each Component of Auto-body electrical System
- Grasp the Maintenance Diagnosis Method of Each Component of Auto-body electrical System

Contents



1. Assistant Constraint Unit (ACU)

2. IMMO Anti-theft System

3. Tire Pressure Monitoring System

1.1 The Constitution of Airbags

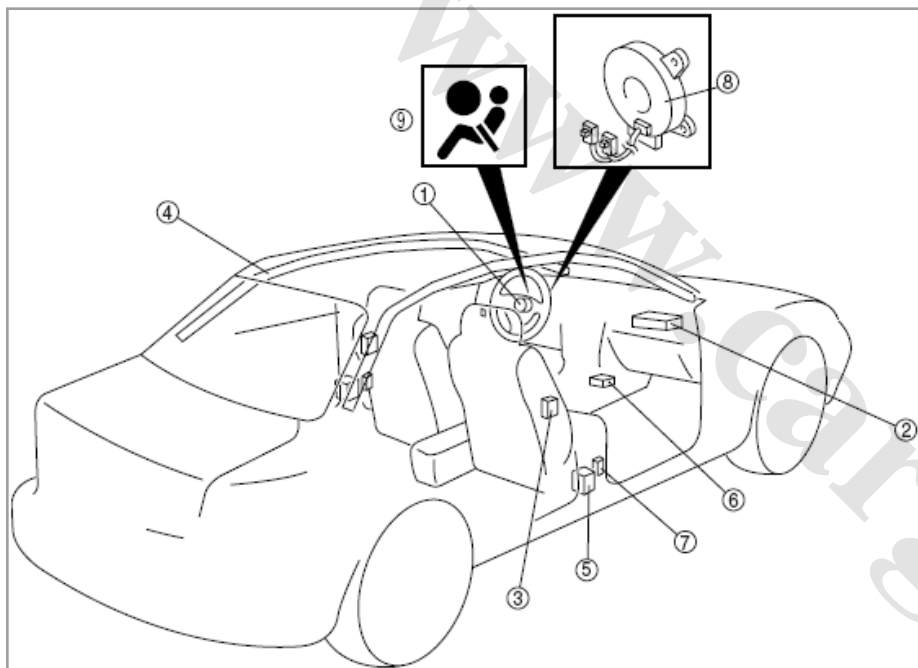

1	Component Elements of Driver's Airbag	6	Airbag Control Module
2	Component Elements of Passenger's Airbag	7	Side Airbags Collision Sensor
3	Side Airbags	8	Clock Spring
4	Side-curtain Airbags	9	Failure Alarming Lamp of Airbag System
5	Anterior Buckle of Seat Belt Pre-tightening Device		

1.2 Schematic Diagram of Airbags

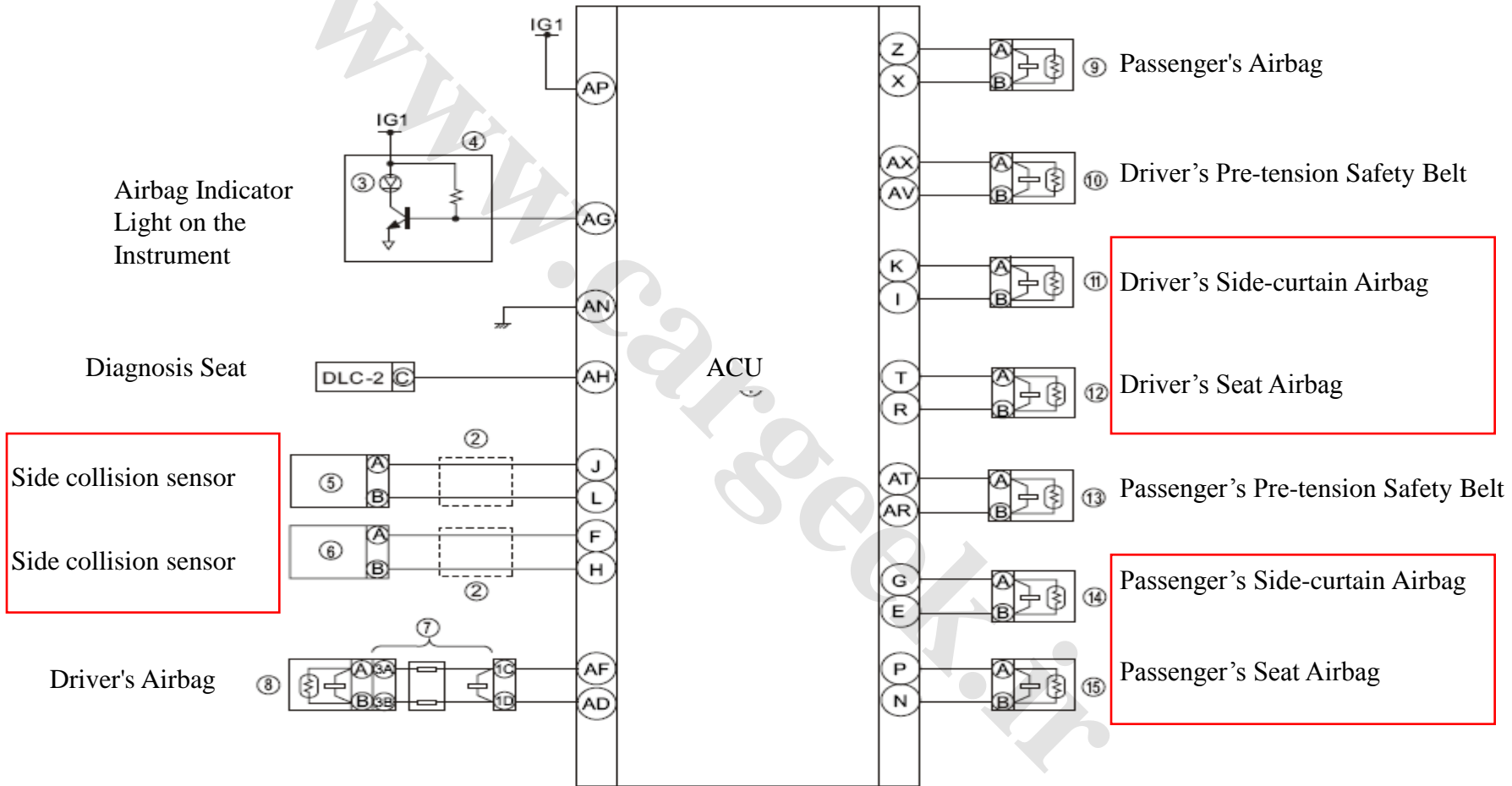

The items in the box are the 6 airbags optional fitting devices

1.3 Airbag Modules



- Mounting position: The floor under the middle of the instrument board
- Continuously monitor the various components of the airbag system.
- Record the detected faults.
- Light failure alarming light.
- Read and clear fault codes with diagnostic tools
- *Note:*
 - *Be sure to disconnect the negative pole of the battery before the demolition of any airbag to wait at least 1 minute, and remove the airbag and the gossamer coils for storage before repairing the steering system.*
 - *Even if the power is cut off, the capacitance inside the airbag computer can provide energy reserve for the airbag system;*
 - *There are built-in short-circuit bars in the connector connected to the airbag module, if the connector on the module is not connected well, the airbag fault light will be on.*
 - *There is a forward arrow on the airbag module. The installation must be operated in the correct direction.*

1. Assistant Constraint Unit (ACU)

www.CarGeek.ir



Passive Safety : 6 Airbags



- Six Airbags & Air Curtain Device.
- Dual front airbags. The volume of driver's airbag is 45 L, whose reaction time is less than 6ms; the volume of co-driver's airbag is 110 L, whose response time is less than 8ms.
- The volume of the seat side airbag and the seat airbags are 7 L, whose response time is less than 2.3ms.
- The side curtain airbags with side impact sensor.
- Compressed nitrogen will explode at the temperature as low as 45 °C .

Airbags Detonating Conditions

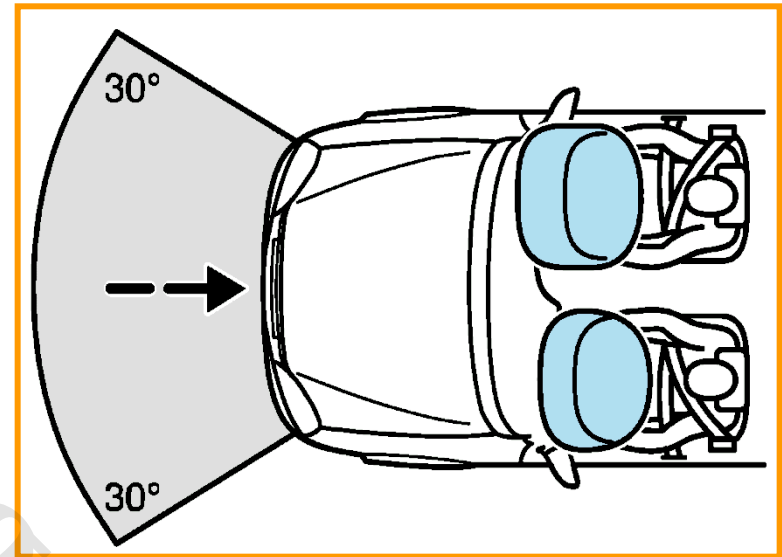
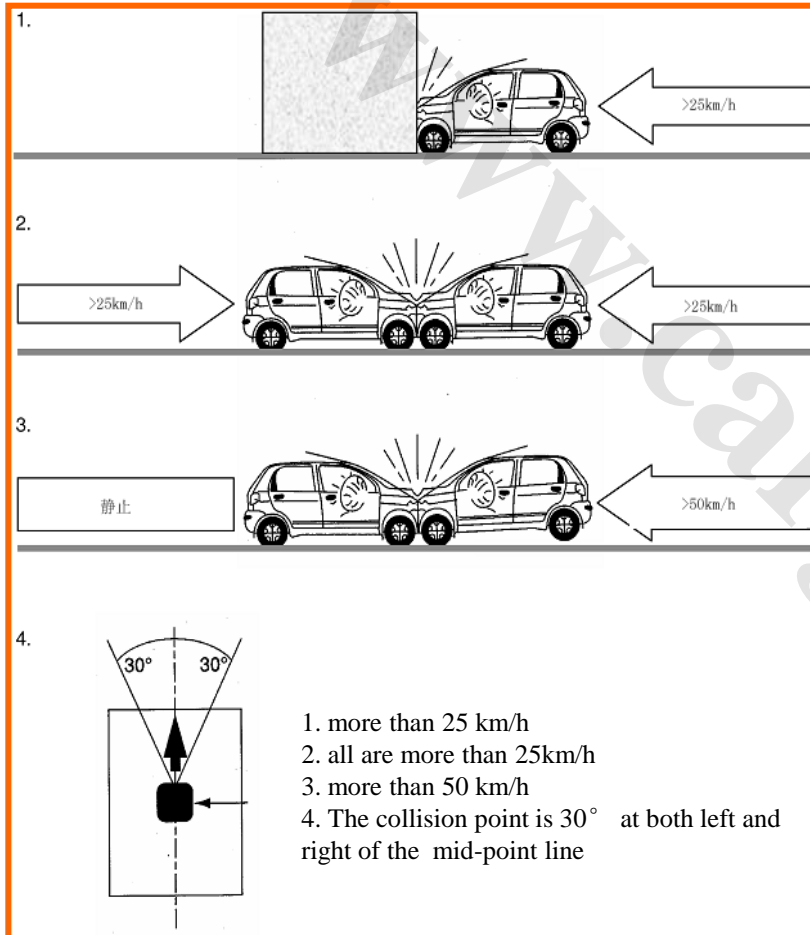

1.4 The Components of the Driver's Airbag

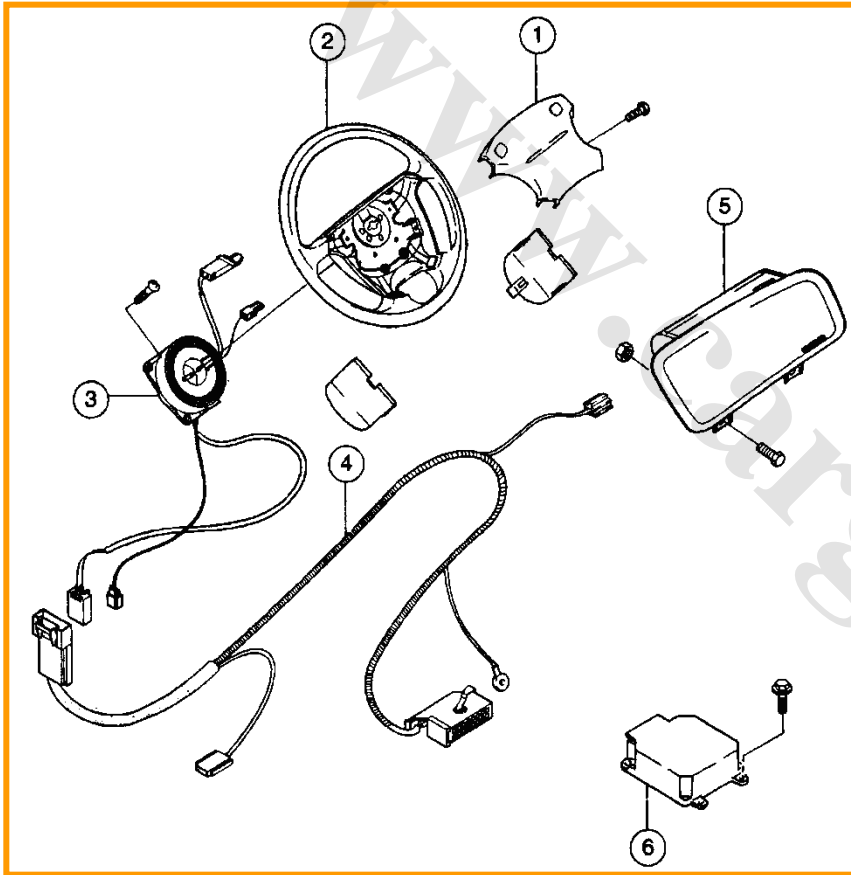

1. Airbag (Driver's)
2. Steering wheel
3. Spiral Coil
4. wiring harness
5. Airbag (Copilot's)
6. Airbag module

1. Assistant Constraint Unit (ACU)

www.CarGeek.ir



Driver's Airbag



- Mounting position: on the steering wheel.
- The airbag is composed of fusing device, powder (gas generator), airbags, stent, and etc.
- The airbag is one-off and must be replaced after blasting
- The failure of the airbag can only be tested by the diagnostic equipment.
- *Note:*
 - *When placing the airbag, keep the airbag facing up in the room, so if the airbag is accidentally detonated it can be in the room, and if not in the room, the airbag could be detonated to the persons or objects, causing accidental injury.*
 - *Don't use the multimeter to carry out the resistance measurement of the airbag.*

1.5 Steering Wheel Spiral Coil



➤ Installation location: under the steering wheel, above the steering column.

It is between the steering column wiring harness and the driver's airbag. The horn lines are also on the coil.

➤ *Note:*

• *Turning the steering wheel more than 2.25 laps may damage the coil.*

• *The decomposition of the coil may cause accidental injury, so if the airbag has been detonated the screw coil must be replaced.*

➤ The removal / replacement of the spiral coil

Be sure to check whether the positions of the coil and the steering gear box are in the middle when demounting and replacing the coil.

➤ *Note: To ensure the middle position, slowly turn the coil until you can feel the resistance, then rotate 2.25 laps back to align the middle mark.*

1.6 Pre & Post Rows Pulling-through Gas Curtain



➤ Mounting Position: Through B-pillar from A pillar to C pillar.

The working principle is the same as the driver's airbag.

➤ *Note:*

- *Only use diagnostic equipment for its detection.*
- *Don't use the multimeter to carry out the resistance measurement of the airbag.*

1.7 Rotating Ball Pre-tightening Seat Belt

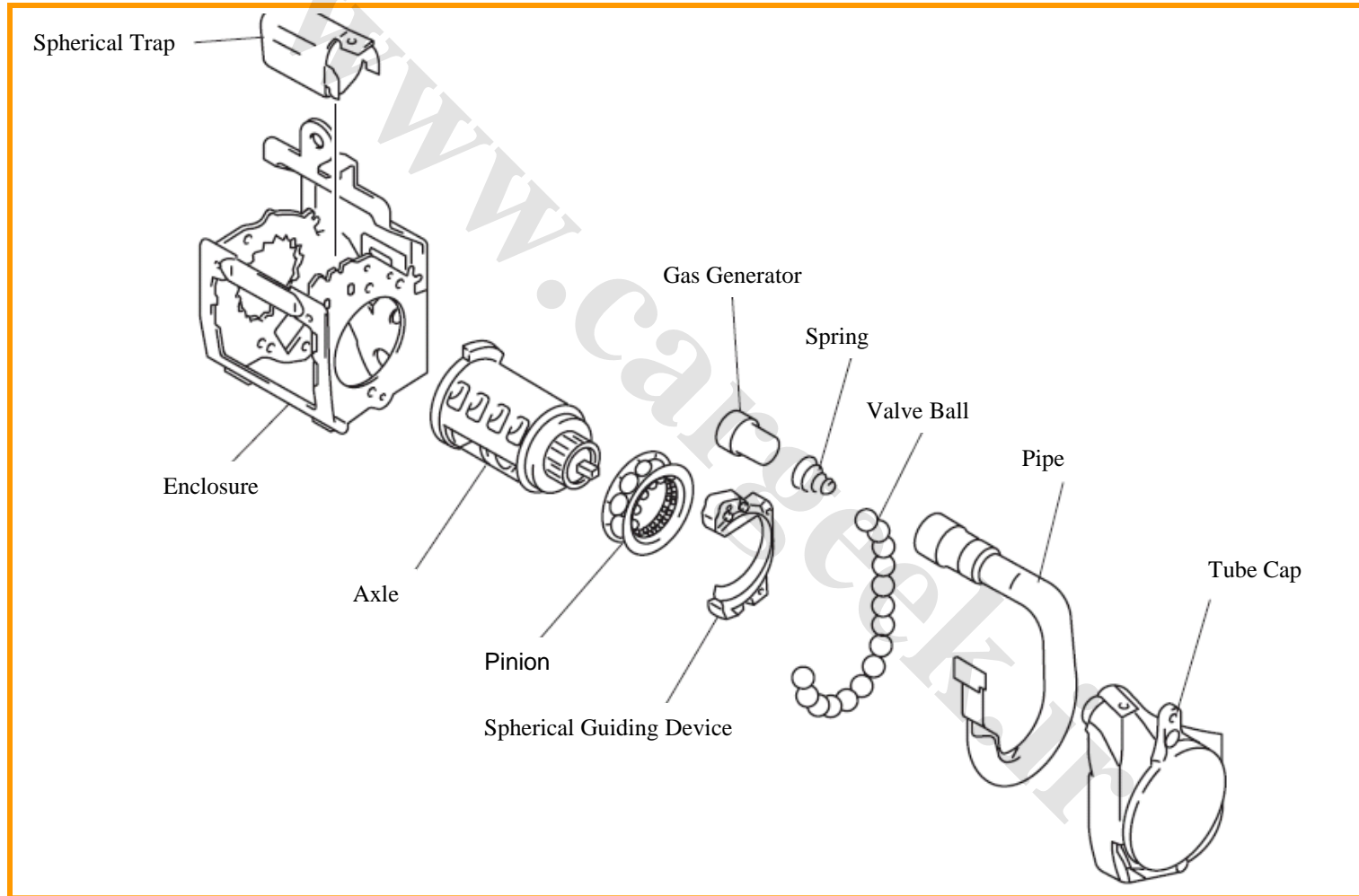

The Working Principle of 'Rolling Ball' Seat Belt Preloader

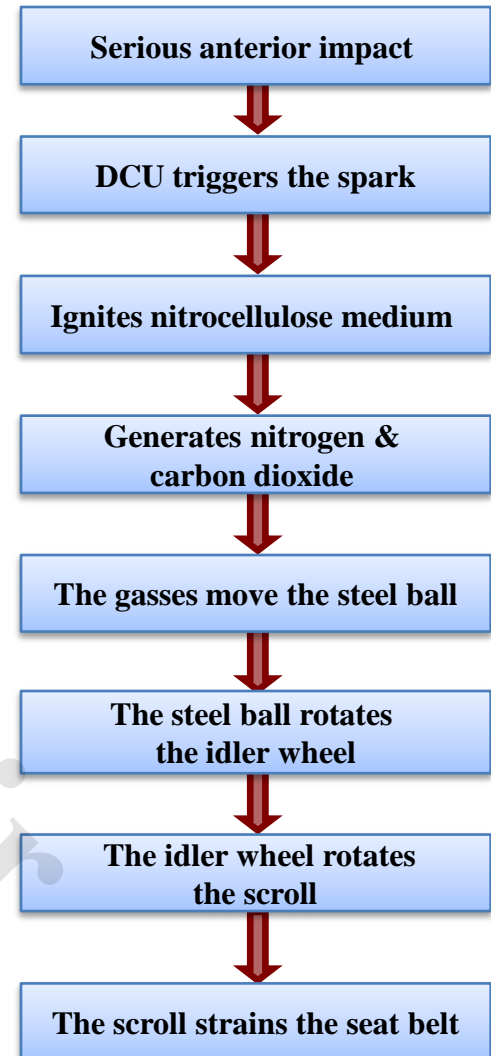
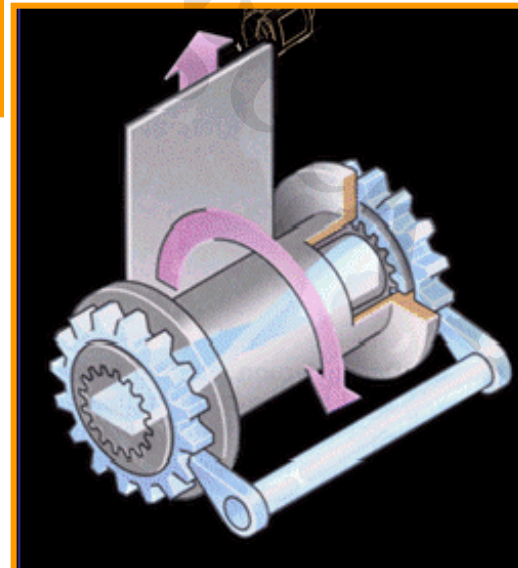
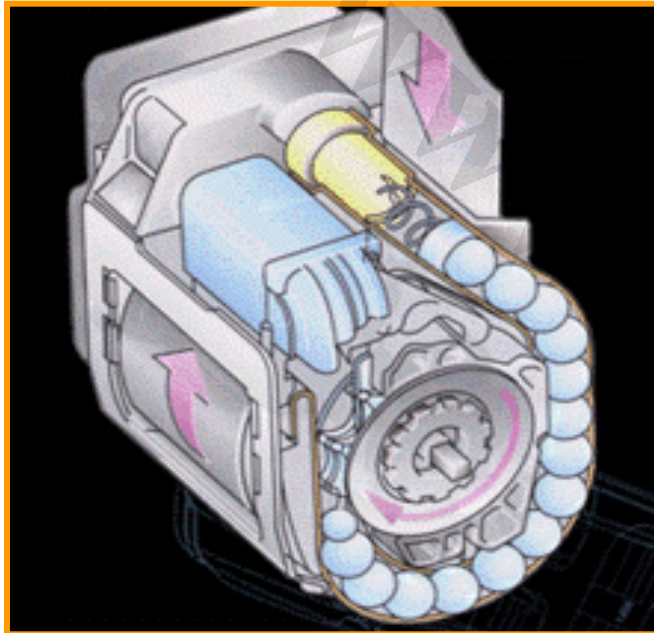

1.8 Side Collision Sensor

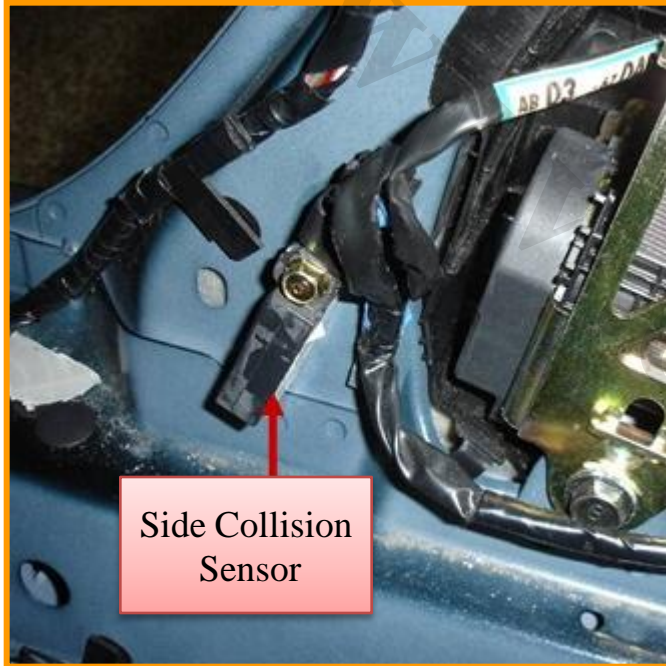

- Vehicles equipped with side airbags, side air curtain will be installed with side impact sensors on the left and right side.
- Installation Location: Below the B-pillars on the left and right sides.
- The side collision sensor senses the impact strength of the sides of the vehicle, and sends the signal to the airbag module to determine whether to open the side airbags or side curtain airbags.
- The side collision sensor can only use diagnostic equipment for its diagnosis.

1.9 Air Alarming Light



➤ Bulb check

As soon as the airbag module receives the input voltage of the ignition, it will activate the alarming light to perform the bulb check. The airbag module keeps the bulb on for 3-4 seconds, then turns off the alarming light, which means the airbag system is normal;

In the detection process of the bulb, the airbag module does not detect crash accidents and will not set off the airbag.

2.1 IMMO Anti-theft Module

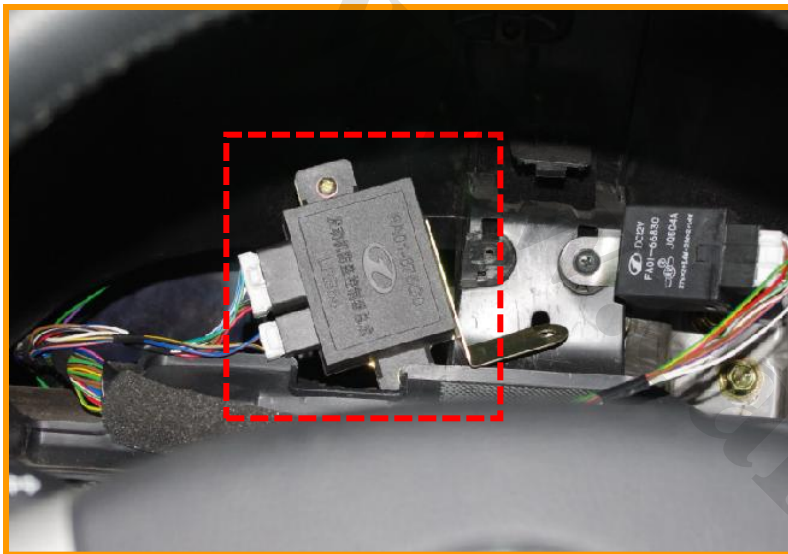

- An electronic anti-theft system consists of:
 - An anti-theft controller
 - A mark identification coil
 - Transponder (remote keyless entry)
 - The coil is installed on the head of the ignition lock cylinder, and the other end is plugged into the anti-theft controller.
- The transponder is installed in the plastic handle of the key, and the chip is bonded with the glue to the handle of the key.

2.2 The Block Diagram of System Control Principle

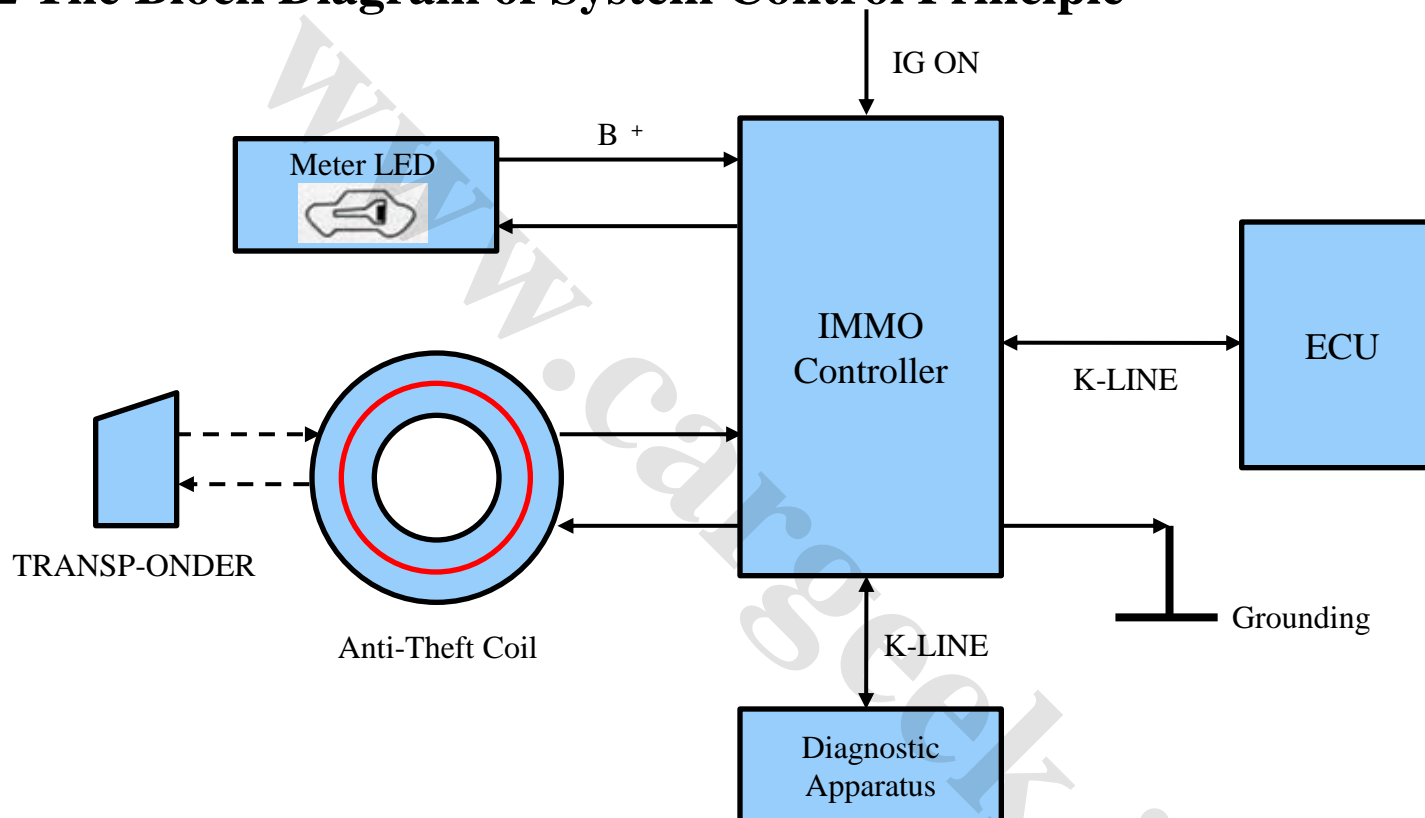

- The anti-theft controller is directly connected to the engine control module, and is connected to the OBD diagnostic interface through K-line.
- When inserting the key, the reader coil will read the code information stored in the chip and send it to the anti-theft controller to match with the information code received by the anti-theft. If the keys match, the engine will be allowed to run.
- When the ignition switch is turned to the closed position, and the key is pulled out from the switch, the anti-theft controller enters into the activated stage. Inserting the legitimate key into the ignition switch can remove the anti-theft state.

2. IMMO Anti-theft System

www.CarGeek.ir



Serial number	Name	Part number	Remark	Whether matching is needed when renewing/adding
1	New anti-theft – Anti-theft controller boundary stents assembly	FC01675G0		YES
2	New anti-theft – Anti-theft coil	FC0066938		NO
3	The main key blank -- New anti-theft with chips	BP00762GXA	Holding at least one original key to the car to match the tooth profile	YES
4	New anti-theft keys assembly	FC0009010A	Including the keys of the whole car, Anti-theft coil and 2 keys	YES
5	Control module- New anti-theft (2.3+ with OBD)	L3VA18881	No Anti-theft procedures in PCM	NO
6	Combination meter assembly	FC0155430	Mainly the meter safety indicator light	NO

2.3 Circuit Structure

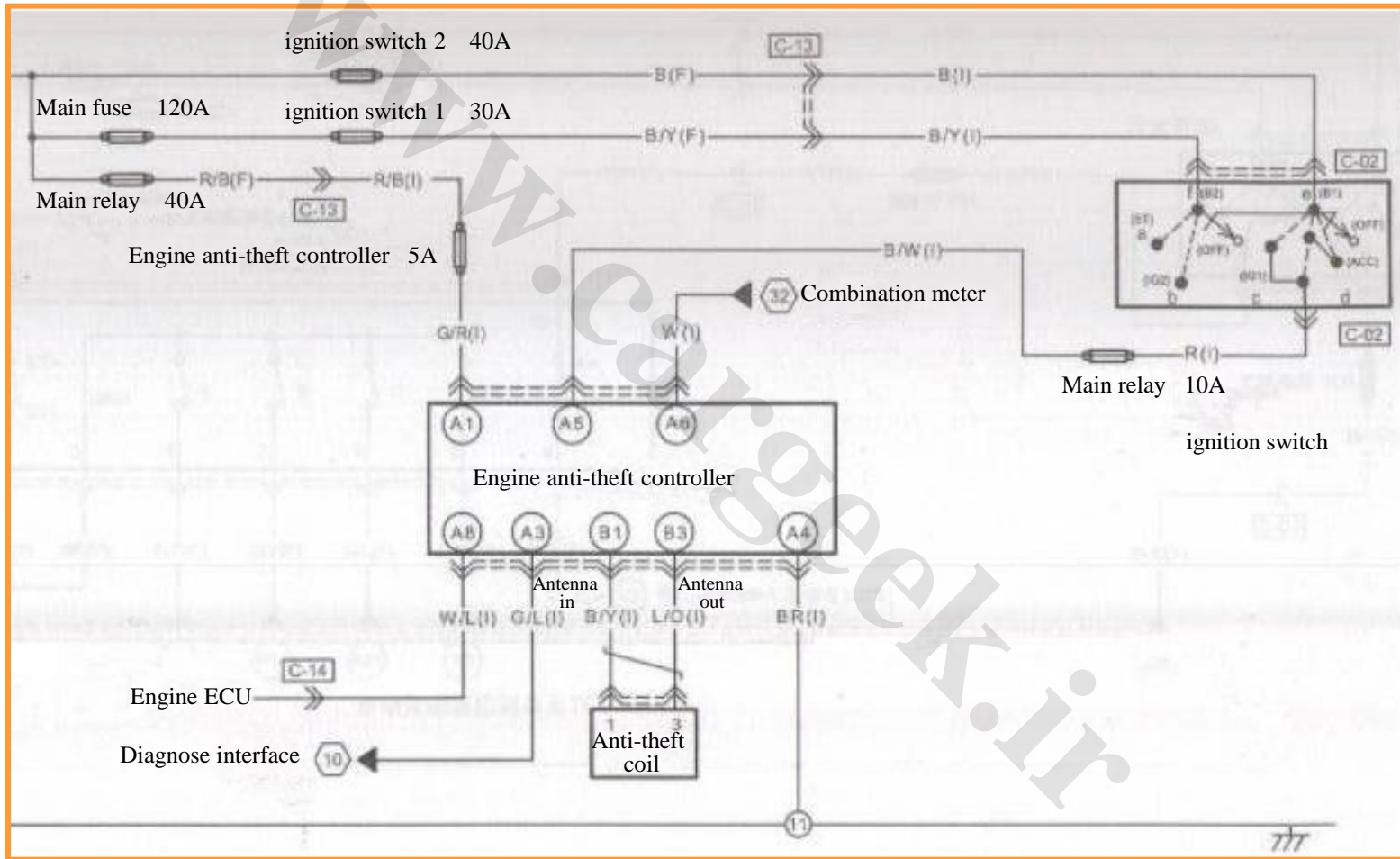

2.4 Key Chips (Transponder)

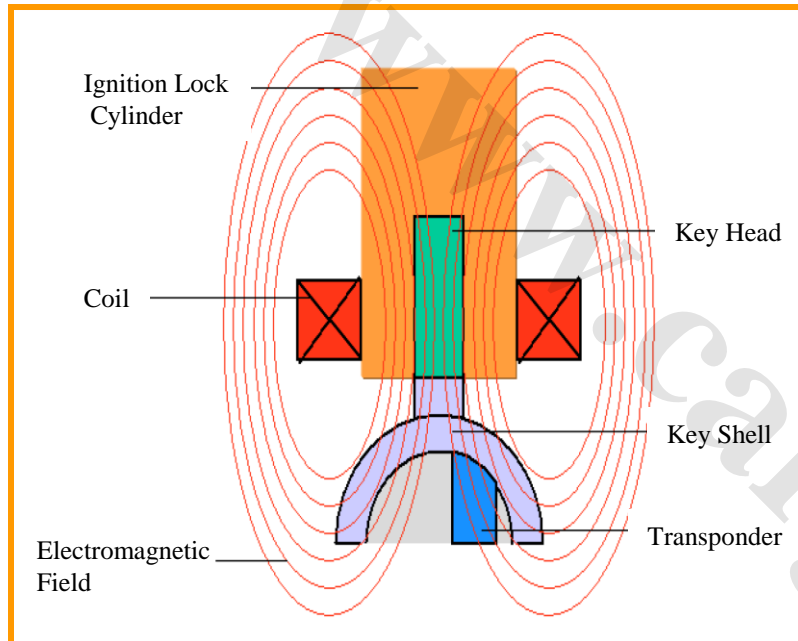

- Transponder (Chips, remote control key)
The transponder, with a small size and a long life, is installed in the key shank and does not take power supply. By incentives in an electromagnetic field, it gains the power signal and the clock signal, and then communicates with the anti-theft controller. Each car can only be assigned up to five transponders, namely five keys, key chips can be written only once.

2.5 Reading Coil



- **Position:** On the lock cylinder of the ignition switch
 - **Function:** Reads the key information from the key chip, and sends this signal to the anti-theft controller.
 - **Structure:** Reading coil is located inside a black plastic cover, which covers around the ignition switch. The coil has two wiring harness which are connected to the anti-theft controller.
- **Reading Coil**

Working Principle: The coil gains power from the modulated current of the anti-theft controller. When the key is within 2cm (0.78in) away from the ignition coil and the ignition switch is on the 'ACC', an electrical energy with the frequency of 125kHz and similar to the transmitter working principle is transmitted from the coil to the anti-theft controller. The anti-theft controller re-modulates and re-encodes the received data, and compare it with the saved identification code. If the data is correct, the engine will be allowed to run.

3.1 The Schematic Diagram of the Tire Pressure Monitoring System Structure

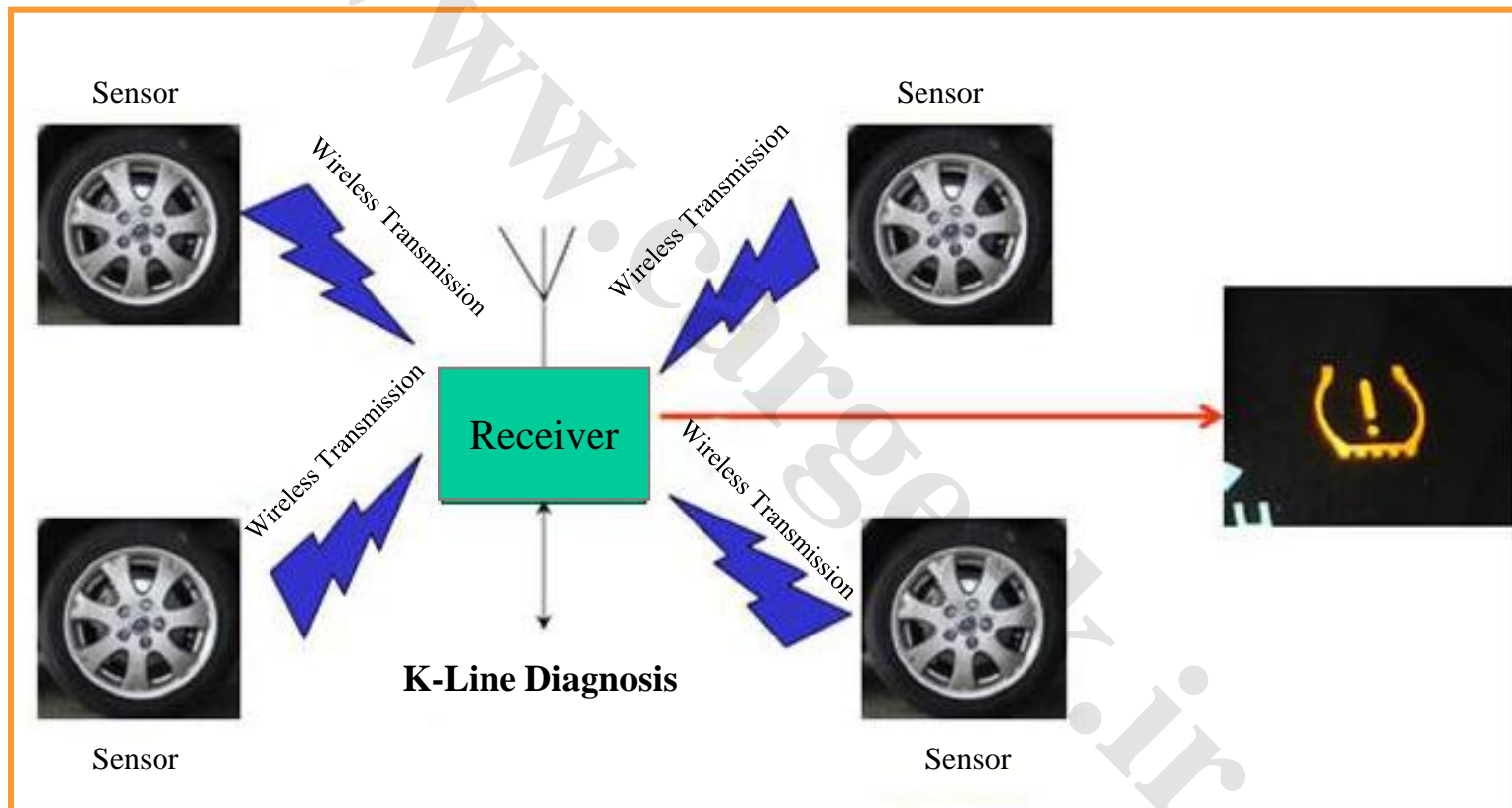

3. Tire Pressure Monitoring System

TPM System for the Position Identification of Vehicles

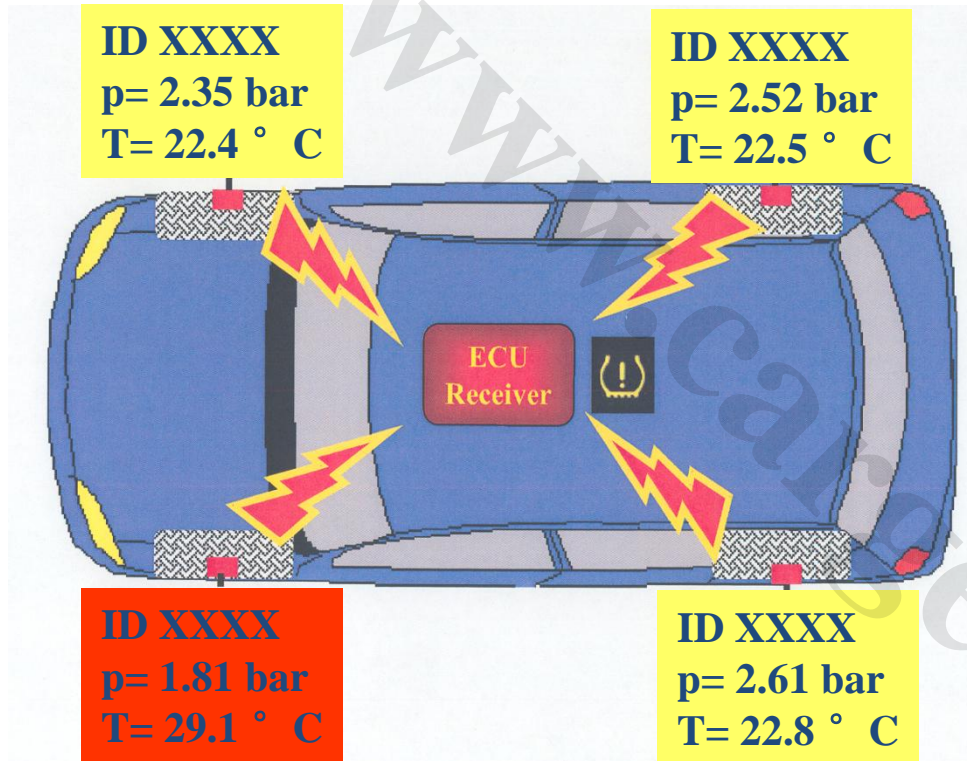

Consists Of:

- 4-wheel Electronic Unit
(Spare Tire is the ordinary tire)
- Control Unit with Receiver
- Receiving Antenna
- Transmission Path
- Combination Meter Display



3.2 Tire Pressure Monitoring Module

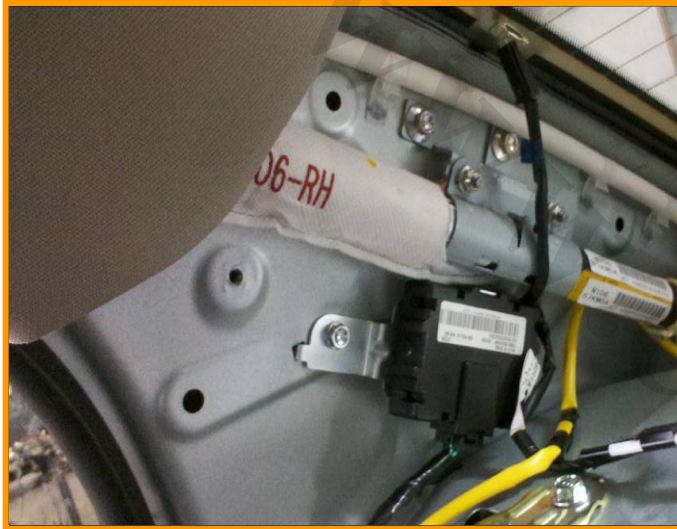

- The tire pressure sensor transmits data with a fixed frequency, which is then received by the central control system and anti-theft alarming antenna and passed to the control unit of the tire pressure monitoring system.
- Installation location: in the inside plate shroud on the right C pillar.

➤ Work-based logic of the tire pressure alarming receiver

Vehicle State	Alarming light controlling logic (it is in the combination meter. Low level is valid)	Remark
Turn the ignition switch to 'ON'. The system tests itself	Be continuously on for 3 seconds	—
System Failure (Battery low voltage warning, sensor failure, and etc)	Warning lights Flash for $72 \pm 10\%$ seconds, then keep on	Flashing frequency: 1Hz
Low tire Pressure (lower than 25% standard tire pressure)	Warning lights are on	Standard tire pressure: 220kpa
No failure	After the system self-test, extinguish the warning lights	—

3. Tire Pressure Monitoring System

3.3 Tire Pressure Sensor

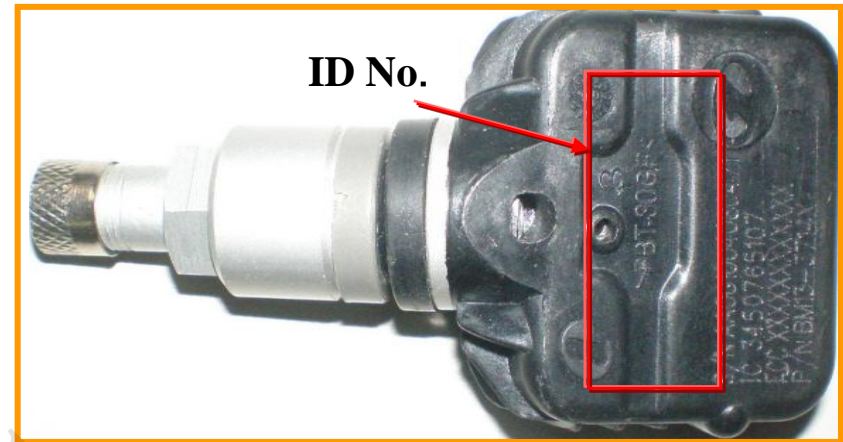

- Loaded with Maxell: CR2450HR button battery. Working time:> 5 years.
- Sensor IC 10 (i.e., ID Number of the sensor) of the decimal number on the label.
- When replacing the tire pressure sensor, the ID number should be written into the tire pressure alarming receiver.

3. Tire Pressure Monitoring System

Work Patterns of Tire Pressure Sensor

Pattern Description	Static Mode	Work Pattern	Quick Launch Mode
Work Pattern Condition	Acceleration Parameter: RS=0	Acceleration Parameter: RS=1	1. A measurement period ($t < 30s$) pressure changes $\geq 20kpa$ 2. Pressure changes of two consecutive launches $\geq 10kpa$ When either of the above conditions is met, switch to the quick launch mode
Arousal Interval of The Sensor	$4s \pm 20\%$	$4s \pm 20\%$	$0.8s \pm 20\%$
Pressure Measurement Interval	$180s \pm 20\%$	$32s \pm 20\%$	$0.8s \pm 20\%$
Temperature Survey Interval			
Acceleration Measurement Interval	$60s \pm 20\%$	$180s \pm 20\%$	No measuring
Radio-frequency Emission Interval	$180s \pm 20\%$	$180s \pm 20\%$	$0.8s \pm 20\%$
Low Frequency Commands are Allowed	Yes	Yes	No
Mode Switch	Acceleration parameter: RS=1 switched to the work pattern	Acceleration parameter: RS=0 switched to the static Mode	Return to the previous mode (static mode or working mode) after completing

Tire Pressure Sensor Learning Notes



- Using diagnostic equipment for the learning function of the tire sensor
- The four tire pressure sensors: left front, right front, left rear, right rear are defined as Sensor 1, Sensor 2, Sensor 3 and Sensor 4.
- After replacing the tire pressure sensor or the unoriginal car tires (with sensors), we need to perform the tire pressure sensor learning. (You can only learn the newly replaced sensors)
- Read the sensor ID before rotating the tires, and pay attention to make the difference marks. (Note: No need to learn the sensor after rotating the tires, because the tire pressure alarm receiver will alarm no matter which one / several wheels pressure is too low.)
- TPMS data record read by the diagnostic equipment displays as the ID identification, which is a 10 decimal digit number. The ID number on the sensors must be accurately input.

3. Tire Pressure Monitoring System

3.4 Tire Pressure Monitoring Schematic

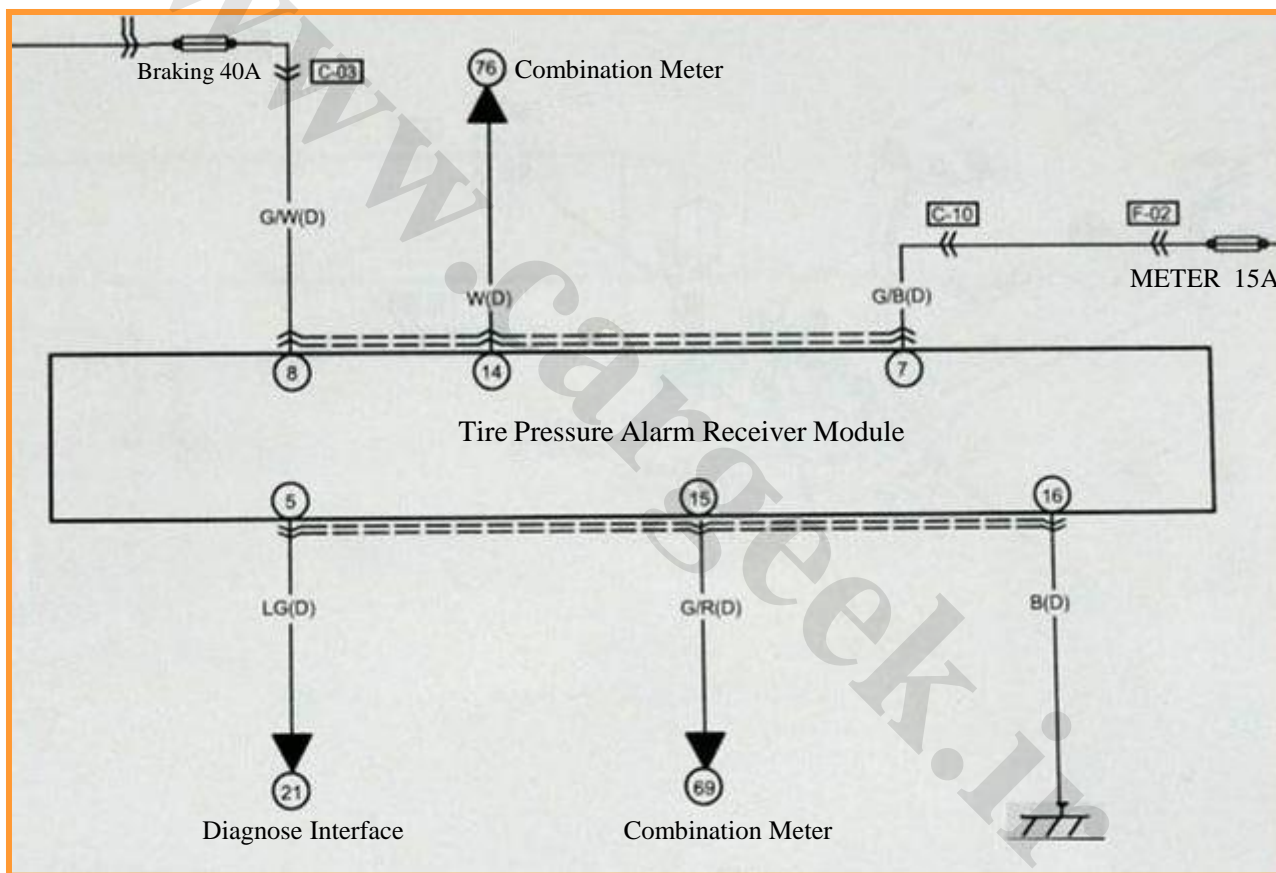

www.cargeek.ir
Thank you!

奔腾 BESTURN

BESTURN Vehicle 50 components understanding classroom practice work

1. Mark location of the vehicle electronic modules and describe :(mark numerical sequence in the correct position, figures corresponding with tables)

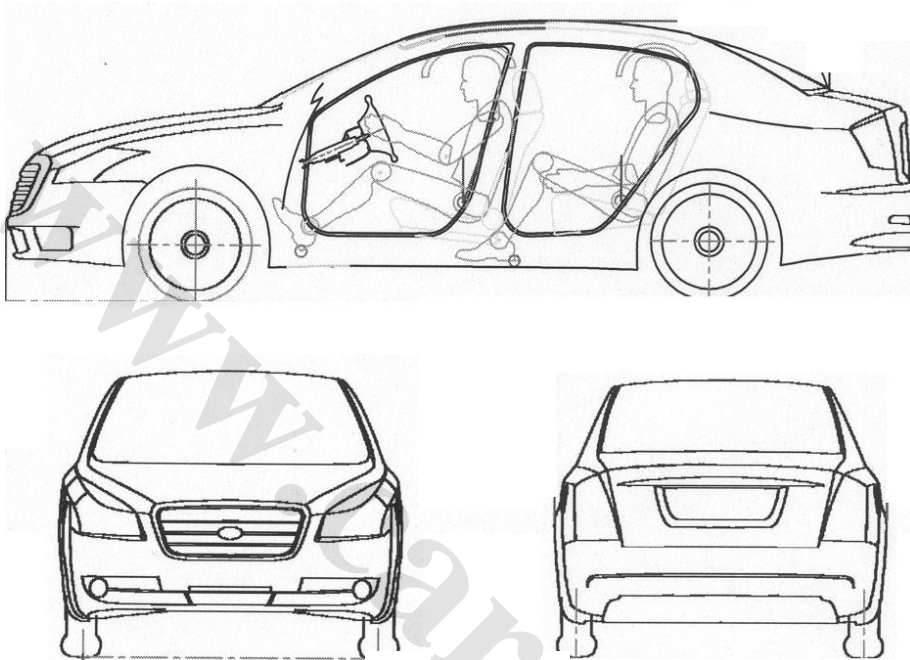

Figure 1

1.	PCM	5.	IMMO	9.	GETWAY
2.	TCM	6.	ACU	10.	TPMS
3.	IC	7.	ABS(DSC)	11.	Diagnostic socket
4.	BCM	8.	DSCU	12.	Parking Distance Control

2. Lists the main engine sensors and actuator positions (labeled for example: - intake air pressure sensor). Write 10 PCM related component names on each engine at least.



Figure 2

3. Operate the diagnostic equipment according to following steps

Self Test: Check and clear the fault code of each module

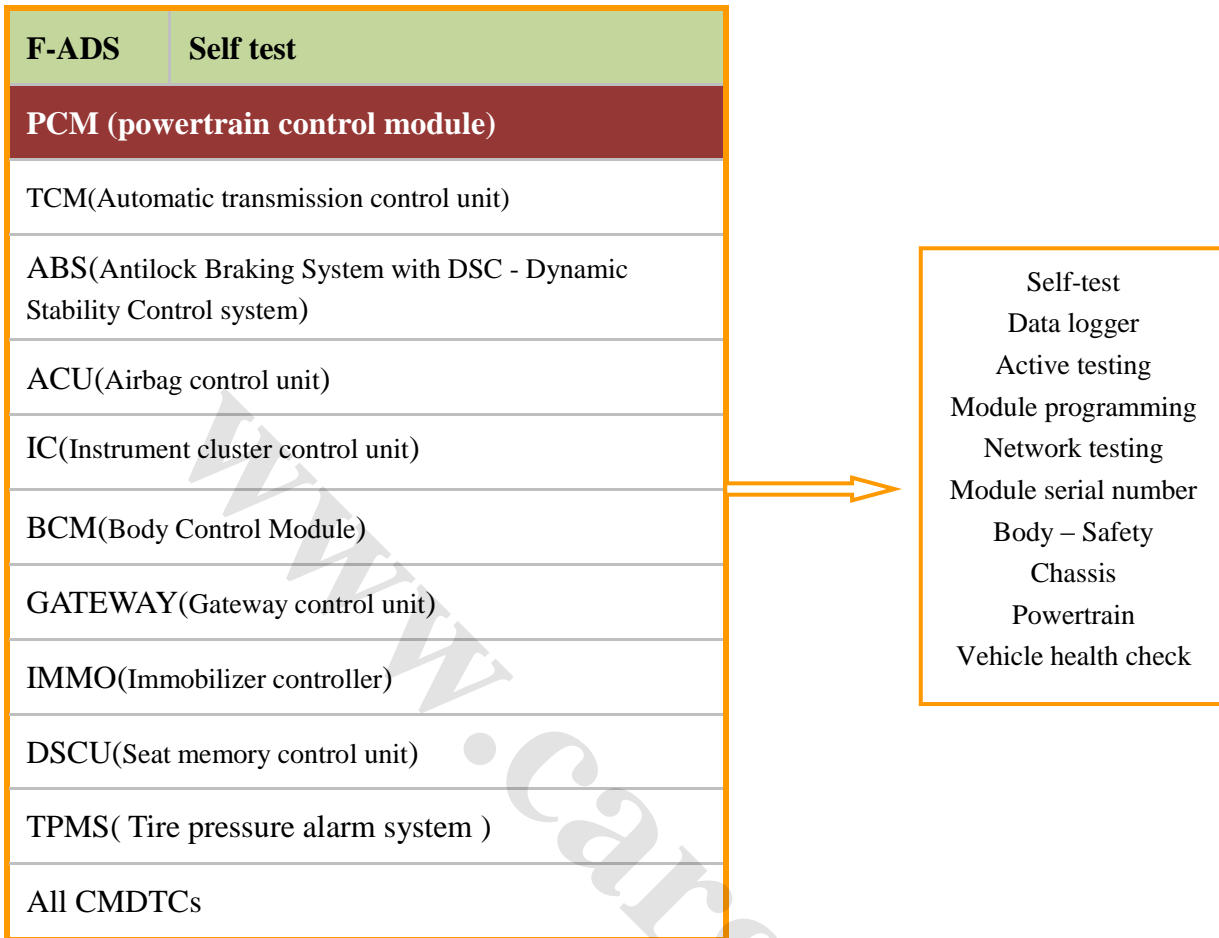

Figure 3

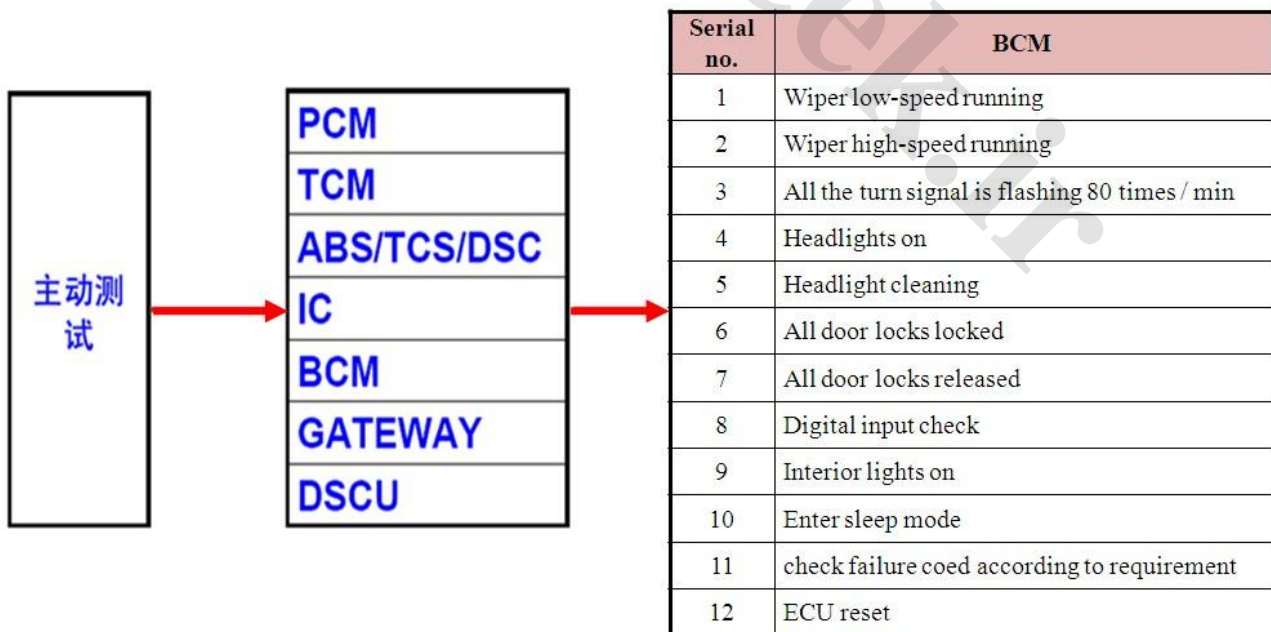

Figure 4

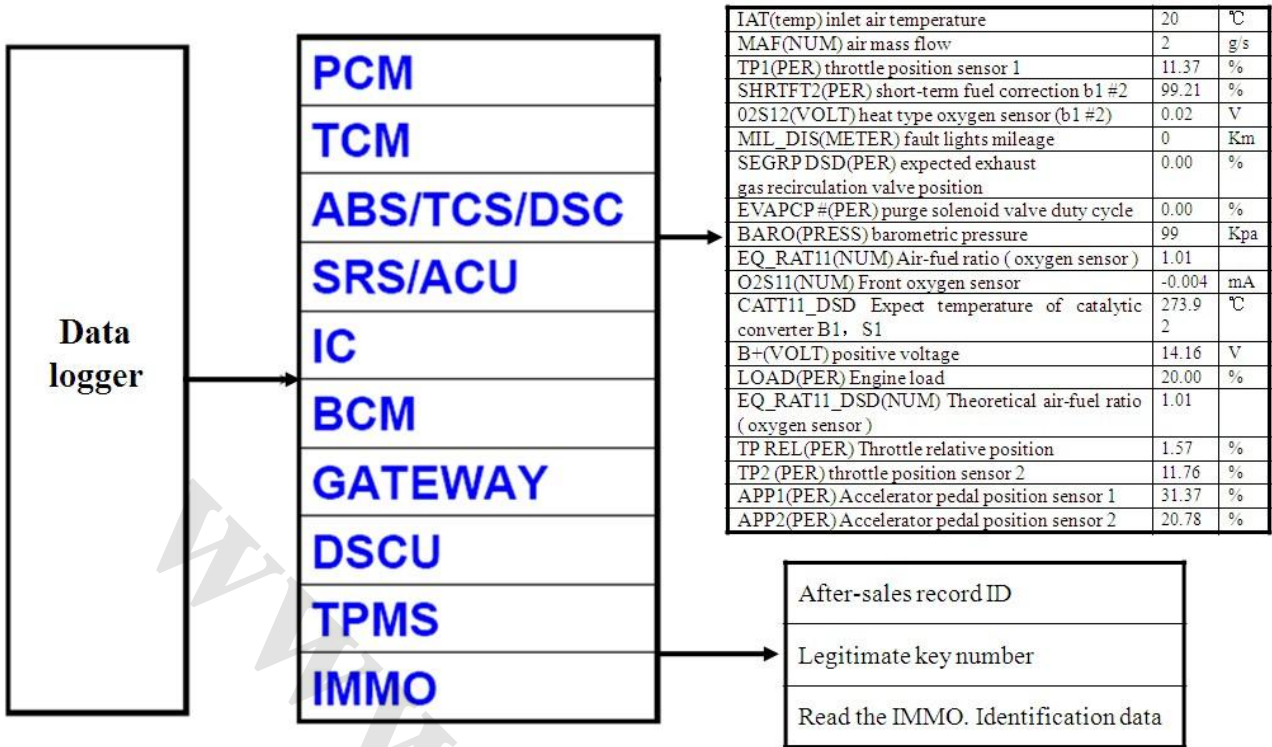

Figure 5

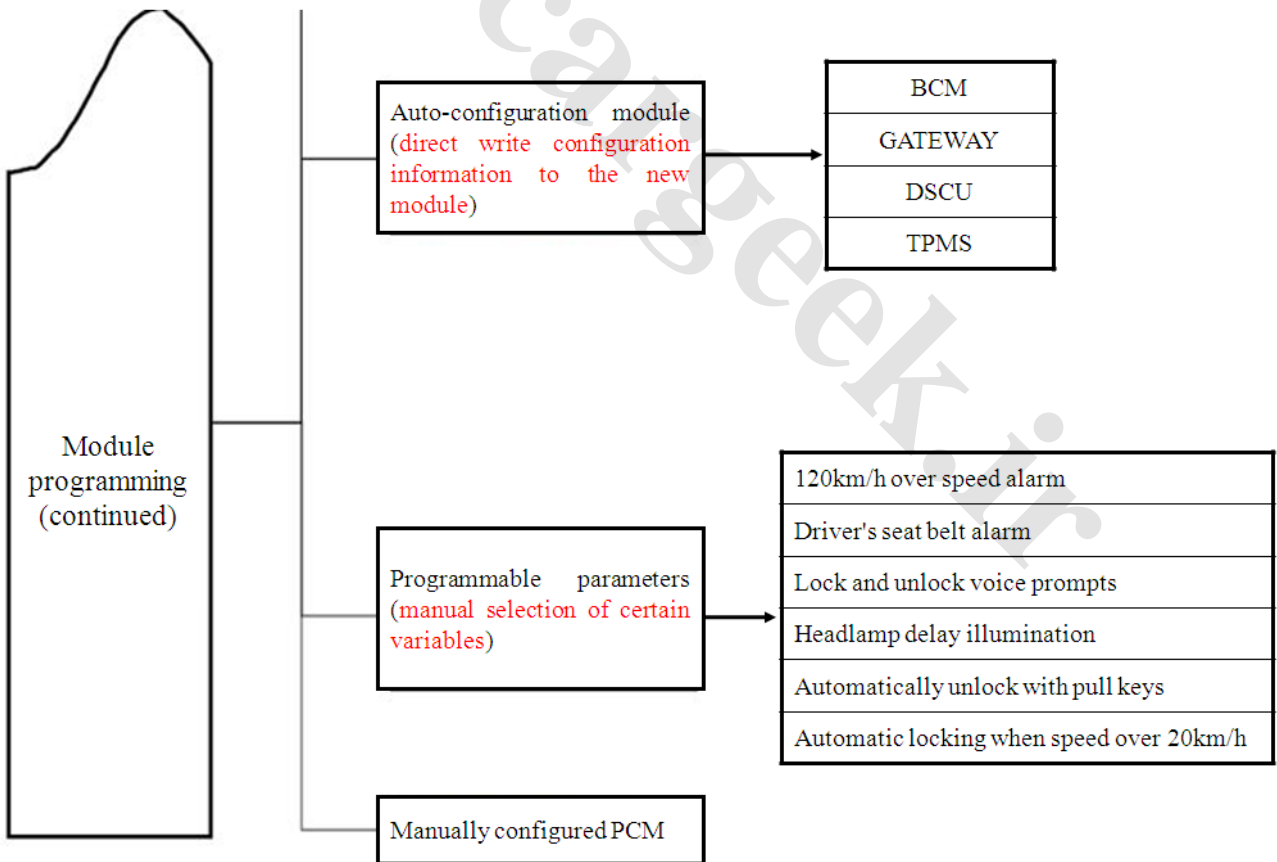

Figure 6

4. Draw timing install mark on the parts

BWH Timing chain installation mark

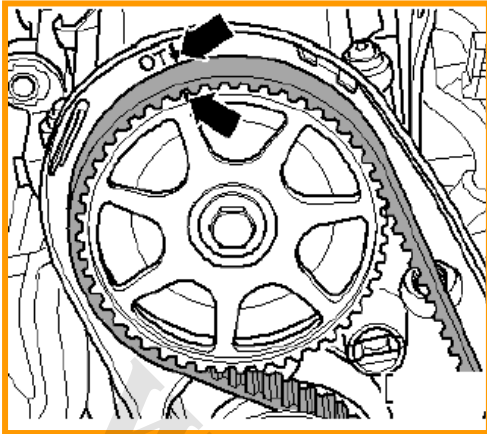

Figure 7

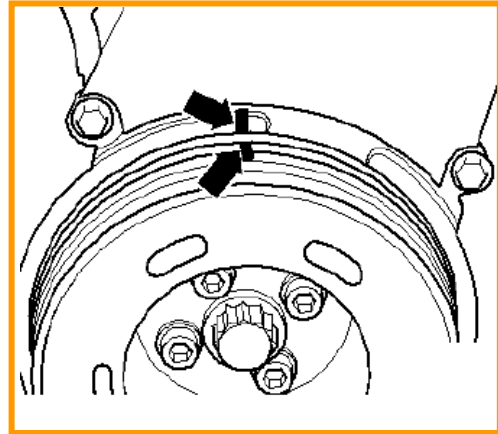

Figure 8

5. Main ground locations of the standard vehicle (at least 10 , and explain its role in the table when use the maintenance manual , marked number in the figure)

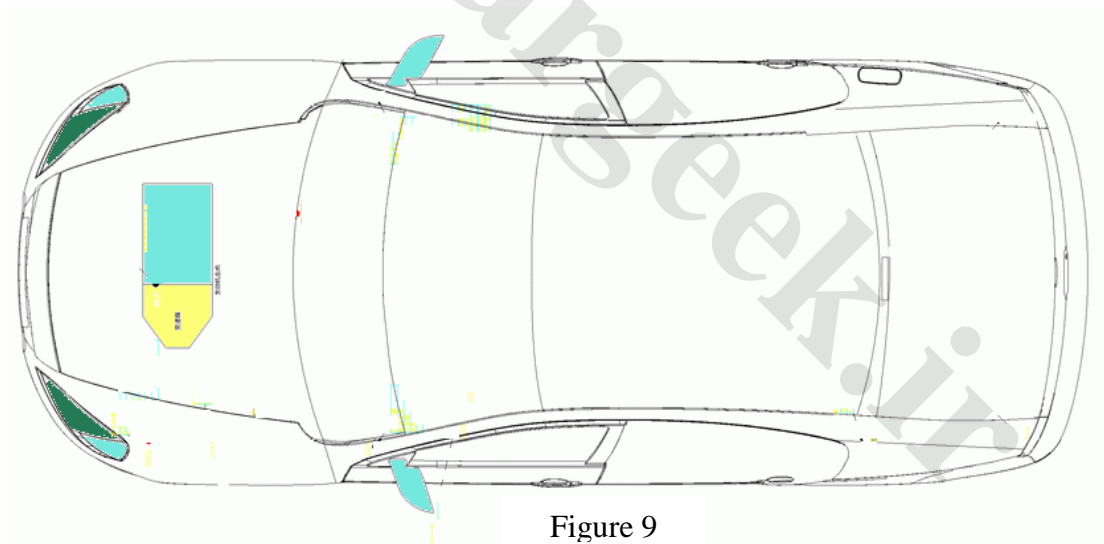

Figure 9

1.		5.		9.	
2.		6.		10.	
3.		7.		11.	
4.		8.		12.	

6. Engine data stream read(B50)

ECU item		Relevant data item	Key-on	Idle speed	Change analysis
1.	Speed				
2.					
3.	Accumulator voltage				
4.	Air inlet				
5.					
6.					
7.	Fuel injection pulse width				
8.	Coolant temperature				
9.	Intake air temperature				
10.	Idle speed				
11.					
12.	Accelerator pedal stroke				
13.					
14.					
15.	Intake manifold pressure				
16.					
17.	Upstream (front) oxygen sensor				
18.					
19.					
20.	Downstream (rear) oxygen sensor				
21.					
22.	Throttle				
23.					
24.					
25.					
26.					
27.					
28.	Accelerator pedal position				
29.					
30.					
31.	Ignition advance angle				
32.					
33.					

34.	Canister				
35.	Vehicle speed				
36.	Knock				
37.					
38.	Air-fuel ratio correction				
39.					
40.					
41.	Load and torque				
42.					
43.	Intake air temperature voltage				
44.	OCV				
45.					
46.					
47.	VTCS				
48.					

7. Measure components with multimeter(B50)

- (1) The measured injector coil resistance with multimeter ohm range at room temperature is _____.
- (2) The measured engine ignition coil primary coil resistance with multimeter ohm range at room temperature is _____, secondary coil resistance _____, and high-voltage line resistance is _____.
- (3) The measured water temperature sensor resistance with multimeter ohm range at 20 degree is _____, resistance at 80 degree is _____.
- (4) The measured canister solenoid valve resistance at room temperature is _____.
- (5) The measured throttle position sensor output voltage signal with multimeter volt range at full closed is _____, voltage at full open is _____.
- (6) The measured resistance between two coils of throttle motor is _____.
- (7) The measured intake air pressure sensor output voltage signal at idle speed is _____, voltage value for turning on the ignition but no starting is _____, voltage value for acceleration is _____.
- (8) The measured oxygen sensor voltage signal changing range is _____, oxygen sensor heating

resistance is _____.

- (9) The measured crankshaft position sensor resistance _____, the measured crankshaft position sensor voltage signal for starting engine motor (not running) is _____, measured crankshaft position sensor voltage signal for engine running in idle speed is _____.

8. Fault detection

- (1) Disconnect the water temperature sensor plugs, and detect test data changes in water temperature, then to observe the situation of the electronic fan action.
- (2) Disconnect throttle position sensor connector, then detect test data changes in the fuel injection pulse width.
- (3) Disconnect the brake booster vacuum tube, and detect test data changes of throttle opening and fuel injection pulse width.
- (4) Disconnect the plug of intake air pressure sensor to detect changes in the fuel injection pulse width.
- (5) Observe the test data changes of accelerator pedal position sensor and the throttle motor, as well as throttle position sensor, then understand the change relations.

(6) Disconnect the oxygen sensor plugs to detect changes in the fuel injection pulse width.

9. Automatic transmission practice

Transmission shift solenoid valve test: confirm the F -ADS data stream according to the table below

B50:

Shift lever position		Solenoid valve					
		SLC1	SLC2	SLC3	SLB1	S1	S2
P		○	○	○	○	—	—
R	Speed ≤9km/h	○	○	—	○	—	—
	Speed >9km/h	○	○	○	○	○	○
N		○	○	○	○	—	—
D	1 st gear	—	○	○	○	—	—
	1 st gear engine brake	—	○	○	○	○	○
	2 nd gear	—	○	○	—	—	—
	3 rd gear	—	○	—	○	—	—
	4 th gear	—	—	○	○	—	—
	5 th gear	○	—	—	○	—	—
	6 th gear	○	—	○	—	—	—

10. Suspension and steering system (at least 18 , and mark their names in the table when use the maintenance manual , marked number in the figure)

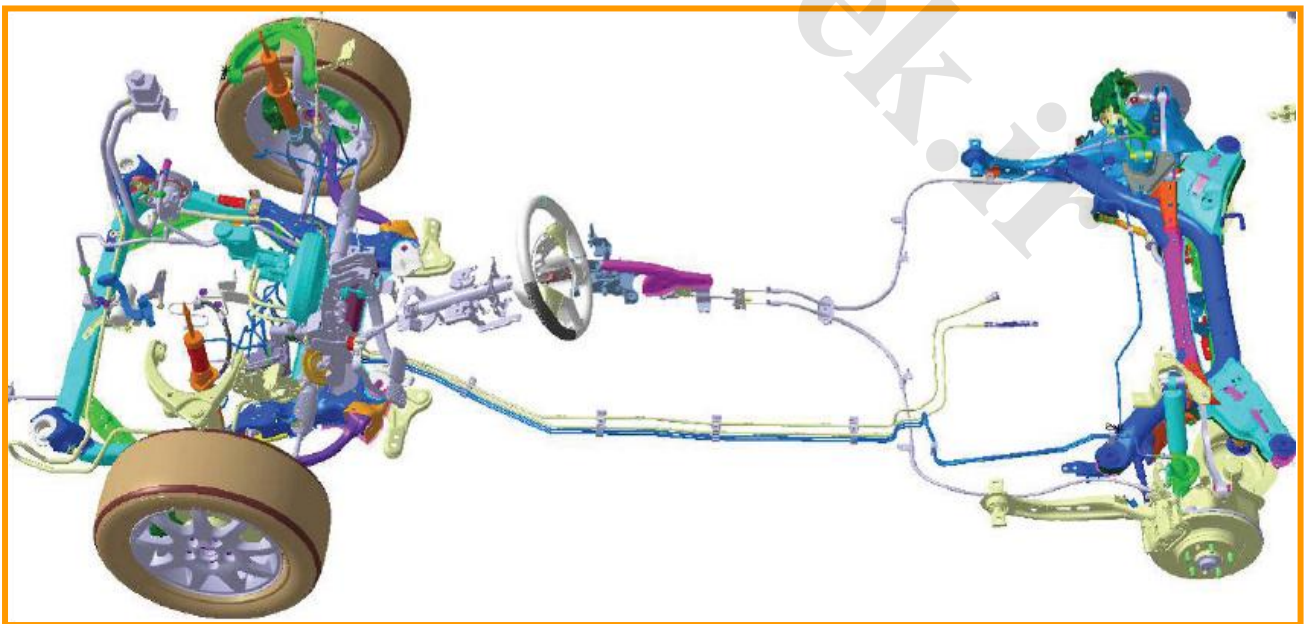

Figure 10

1.		2.	
3.		4.	
5.		6.	
7.		8.	
9.		10.	
11.		12.	
13.		14.	
15.		16.	
17.		18.	

11. ABS diagnostics, write the data analysis and numerical value

Serial no.	Data analysis name	Data change description
1.		
2.		
3.		
4.		
5.		
6.		
7.		
8.		
9.		
10.		
11.		
12.		
13.		
14.		
15.		
16.		

12. Write data flow analysis of ACU system diagnostic instrument

No.		Value	Unit
1	Power supply voltage		V
2	Ignition capacitor voltage		V
3	Channel number		
4	Driver's seat airbag resistor value		Ω
5	Co-pilot 's seat airbag resistor value		Ω
6	Driver's seat belt warning device resistance value		Ω
7	Co-pilot's seat belt warning device resistance value		Ω
8	Side airbags resistance (left)		Ω
9	Side airbags resistance (right)		Ω
10	Curtain airbags resistance (left)		Ω
11	Curtain airbags resistance (right)		Ω

13. Write data flow analysis of BCM system diagnostic instrument

No.		Value
1	FCC part number	
2	BCM supplier information	
3	Module registration code (serial number)	
4	Module registration code (date)	
5	VIN number	
6	BCM software version number	
7	GPN	
8	BCM hardware version number	
9	FCC vehicle production date	
10	BCM system configuration (rain sensor)	
11	BCM system configuration (skylight)	
12	BCM system configuration (left front window CAN configuration)	
13	BCM system configuration (automatic headlight)	
14	BCM system configuration (headlight delay)	
15	BCM system configuration (headlight cleaning)	
16	BCM system configuration (anti-theft system voice prompts)	
17	BCM system configuration (lock/unlock voice prompts)	
18	BCM system configuration (mode)	
19	BCM system configuration (lock automatically when vehicle speed exceeds 20Km/h)	
20	BCM system configuration (unlock automatically when pulling the ignition key)	

14. Write data flow analysis of TPMS system diagnostic instrument

1	Sensor 1learning	
2	Sensor 1learned	
3	Sensor 1position	
4	Sensor 1ID	
5	Sensor 2learning	
6	Sensor 2learned	
7	Sensor 2position	
8	Sensor 2ID	
9	Sensor 3learning	
10	Sensor 3learned	
11	Sensor 3position	
12	Sensor 3ID	
13	Sensor 4learning	
14	Sensor 4learned	
15	Sensor 4position	
16	Sensor 4ID	
17	Sensor 5learning	
18	Sensor 5learned	
19	Sensor 5position	
20	Sensor 5ID	
21	Sensor 1 pressure	
22	Sensor 1 temperature	
23	Sensor 1 transfer type	
24	Sensor 1 electricity quantity	
25	Sensor 2 pressure	
26	Sensor 2 temperature	
27	Sensor 2 transfer type	
28	Sensor 2 electricity quantity	
29	Sensor 3 pressure	
30	Sensor 3 temperature	
31	Sensor 3 transfer type	
32	Sensor 3 electricity quantity	
33	Sensor 4 pressure	
34	Sensor 4 temperature	
35	Sensor 4 transfer type	
36	Sensor 4 electricity quantity	
37	Sensor 5 pressure	
38	Sensor 5 temperature	
39	Sensor 5 transfer type	
40	Sensor 5 electricity quantity	
41	FCC part number	
42	FCC part name	
43	Software version number	
44	VIN	
45	Serial number	
46	Hardware version number	

15. Fill in serial number and corresponding computer pins (B50) for the BCM modules in the principle figure below.

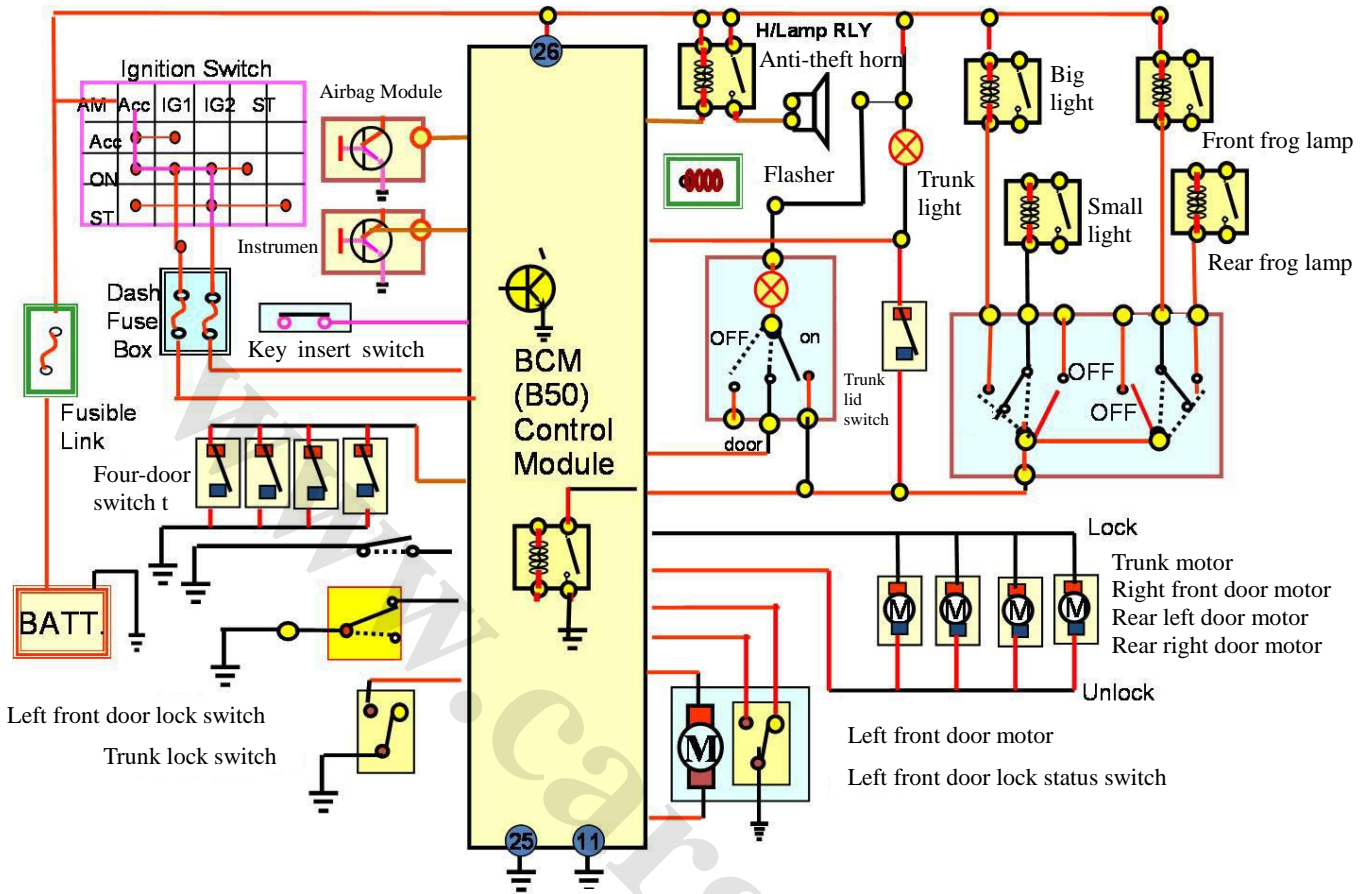

Figure 11

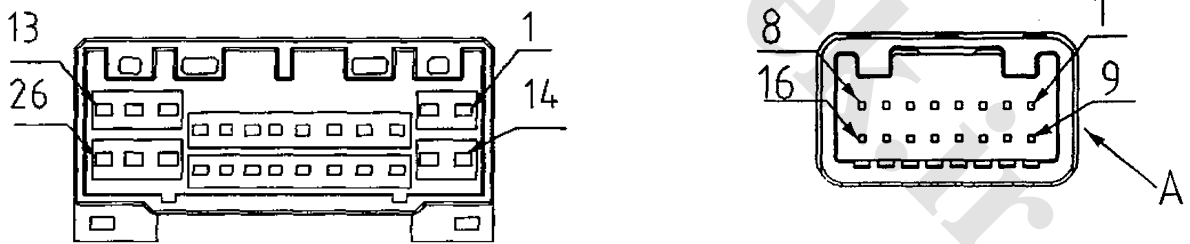

Figure 12

Terminal	Signal name	Signal description	Terminal	Signal name	Signal description
1.			2.		
3.			4.		
5.			6.		
7.			8.		
9.			10.		
11.			12.		
13.			14.		
15.			16.		
17.			18.		
19.			20.		
21.			22.		
23.			24.		
25.			26.		
Terminal	Signal name	Signal description	Terminal	Signal name	Signal description
A1			A2		
A3			A4		
A5			A6		